



US010932634B2

(12) **United States Patent**
Conrad

(10) **Patent No.:** **US 10,932,634 B2**

(45) **Date of Patent:** ***Mar. 2, 2021**

(54) **SURFACE CLEANING APPARATUS**

(71) Applicant: **Omachron Intellectual Property Inc.,**
Hampton (CA)

(72) Inventor: **Wayne Ernest Conrad, Hampton (CA)**

(73) Assignee: **Omachron Intellectual Property Inc.,**
Hampton (CA)

(*) Notice: Subject to any disclaimer, the term of this
patent is extended or adjusted under 35
U.S.C. 154(b) by 12 days.

This patent is subject to a terminal dis-
claimer.

(21) Appl. No.: **16/419,993**

(22) Filed: **May 22, 2019**

(65) **Prior Publication Data**

US 2019/0365174 A1 Dec. 5, 2019

Related U.S. Application Data

(63) Continuation-in-part of application No. 15/993,189,
filed on May 30, 2018, now Pat. No. 10,827,889.

(51) **Int. Cl.**

B01D 45/12 (2006.01)
A47L 9/22 (2006.01)
A47L 9/20 (2006.01)
A47L 5/24 (2006.01)
A47L 9/10 (2006.01)
A47L 9/16 (2006.01)

(Continued)

(52) **U.S. Cl.**

CPC **A47L 9/1658** (2013.01); **A47L 9/127**
(2013.01); **A47L 9/165** (2013.01); **A47L**
9/2842 (2013.01); **A47L 5/24** (2013.01)

(58) **Field of Classification Search**

CPC B01D 46/002; B01D 50/002; B01D 45/12;

B01D 2279/55; A47L 9/102; A47L 9/122;
A47L 9/322; A47L 9/22; A47L 9/20;
A47L 9/2884; A47L 5/24; A47L 9/10
USPC 55/385.1, 429, 433; 15/347, 352, 353,
15/300.1

See application file for complete search history.

(56) **References Cited**

U.S. PATENT DOCUMENTS

4,894,882 A 1/1990 Toya
5,107,567 A 4/1992 Ferrari et al.
(Continued)

FOREIGN PATENT DOCUMENTS

CN 1506016 A 6/2004
CN 1626025 A 6/2005
(Continued)

OTHER PUBLICATIONS

English machine translation of KR1020060122249, published on
Nov. 30, 2006.

(Continued)

Primary Examiner — Minh Chau T Pham

(74) *Attorney, Agent, or Firm* — Philip C. Mendes da
Costa; Bereskin & Parr LLP/S.E.N.C.R.L., s.r.l.

(57) **ABSTRACT**

A surface cleaning apparatus includes an air flow path, a
filter housing, and a filter member in the filter housing. In
some embodiments, the filter member includes a plurality of
individual filter elements arranged in parallel, each includ-
ing porous filter material having at least one upstream face
and at least one portion defining a porous filter media air
outlet. In other embodiments, the filter member has an outer
upstream surface that abuts an axially extending air imper-
meable wall to inhibit bypass of the filter.

25 Claims, 50 Drawing Sheets

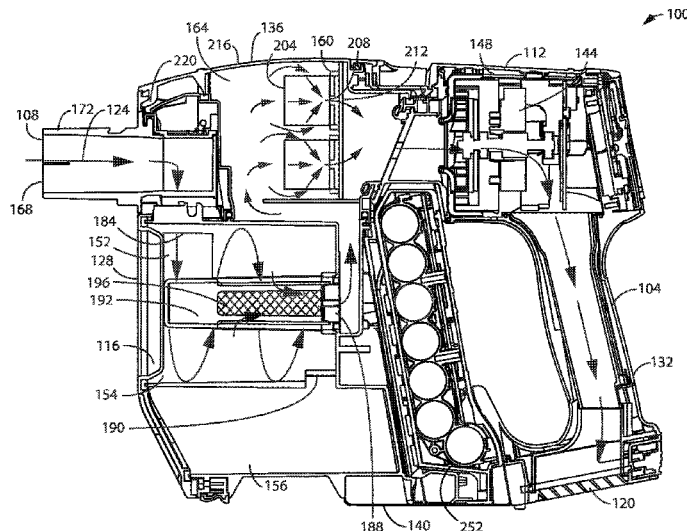

- (51) **Int. Cl.**
A47L 9/28 (2006.01)
A47L 9/12 (2006.01)

(56) **References Cited**

U.S. PATENT DOCUMENTS

5,230,722 A 7/1993 Yonkers
 6,113,663 A 9/2000 Liu
 6,129,550 A 10/2000 Culberson et al.
 6,406,505 B1 6/2002 Oh et al.
 6,775,882 B2 8/2004 Murphy et al.
 6,901,625 B2 6/2005 Yang et al.
 7,335,242 B2 2/2008 Oh
 7,488,362 B2 2/2009 Jeong et al.
 7,540,894 B2 6/2009 Ni
 7,645,309 B2 1/2010 Jeong et al.
 7,708,789 B2 5/2010 Fester
 7,887,612 B2 2/2011 Conrad
 8,206,482 B2 6/2012 Williams et al.
 8,544,143 B2 10/2013 Hwang et al.
 8,997,309 B2 4/2015 Conrad
 2001/0018865 A1 9/2001 Wegelin et al.
 2002/0092119 A1 7/2002 Vystreil et al.
 2003/0084536 A1 5/2003 Yung
 2006/0090290 A1 5/2006 Lau
 2007/0033765 A1 2/2007 Walker et al.
 2007/0067943 A1 3/2007 Makarov
 2008/0178416 A1 7/2008 Conrad
 2010/0236016 A1 9/2010 Tran
 2010/0299866 A1 12/2010 Conrad
 2011/0219570 A1 9/2011 Conrad
 2011/0219575 A1 9/2011 Conrad
 2012/0023701 A1 2/2012 Lenkiewicz et al.
 2012/0304417 A1 12/2012 Riley
 2013/0091660 A1 4/2013 Smith
 2013/0091661 A1 4/2013 Smith
 2013/0232722 A1 9/2013 Conrad
 2014/0237768 A1 8/2014 Conrad
 2016/0120382 A1 5/2016 Conrad
 2017/0290479 A1 10/2017 Conrad
 2017/0290481 A1* 10/2017 Conrad A47L 5/24
 2018/0303301 A1 10/2018 Conrad et al.
 2019/0290084 A1 9/2019 Conrad
 2019/0320863 A1 10/2019 Conrad
 2020/0022546 A1 1/2020 Conrad
 2020/0022547 A1 1/2020 Conrad
 2020/0046190 A1 2/2020 Conrad
 2020/0077854 A1 3/2020 Conrad

FOREIGN PATENT DOCUMENTS

CN 100998484 A 7/2007
 CN 101108106 A 1/2008
 CN 101108110 A 1/2008
 CN 201008534 Y 1/2008
 CN 101288572 A 10/2008
 CN 101288574 A 10/2008
 CN 201131706 Y 10/2008
 CN 101612025 A 12/2009
 CN 101822506 A 9/2010
 CN 202277306 U 6/2012
 CN 103040412 A 4/2013
 CN 103040413 A 4/2013
 CN 102256523 B 11/2014
 DE 10110581 C2 11/2003
 DE 59907201 T2 2/2004
 DE 10360002 A1 12/2004
 DE 50116336 T2 8/2006
 DE 102007011457 A1 10/2007
 DE 102004055192 B4 11/2007
 DE 102005015004 B4 2/2008
 DE 102005008278 B4 3/2008
 DE 102005014541 B4 8/2008
 DE 112007001314 T5 4/2009
 DE 202012101457 U1 8/2012
 DE 112011104642 T5 10/2013

DE 112012000251 T5 10/2013
 EP 1559359 A2 8/2005
 JP 03176019 A 7/1991
 JP 2006272019 A 10/2006
 JP 2010227287 A 10/2010
 KR 1020040050174 A 6/2004
 KR 1020040088978 A 10/2004
 KR 1020050091821 A 9/2005
 KR 1020050091824 A 9/2005
 KR 1020050091826 A 9/2005
 KR 1020050091829 A 9/2005
 KR 1020050091830 A 9/2005
 KR 1020050091833 A 9/2005
 KR 1020050091834 A 9/2005
 KR 1020050091835 A 9/2005
 KR 1020050091836 A 9/2005
 KR 1020050091837 A 9/2005
 KR 1020050091838 A 9/2005
 KR 1020050103343 A 10/2005
 KR 1020050104613 A 11/2005
 KR 1020050104614 A 11/2005
 KR 1020050108623 A 11/2005
 KR 1020060008365 A 1/2006
 KR 1020060018004 A 2/2006
 KR 1020060112420 A 11/2006
 KR 1020060118795 A 11/2006
 KR 1020060118800 A 11/2006
 KR 1020060118801 A 11/2006
 KR 1020060118802 A 11/2006
 KR 1020060118803 A 11/2006
 KR 1020060119587 A 11/2006
 KR 1020060122249 A 11/2006
 WO 9930602 A2 6/1999
 WO 2008070971 A1 6/2008
 WO 2008070972 A1 6/2008
 WO 2008070975 A1 6/2008

OTHER PUBLICATIONS

English machine translation of KR1020060119587, published on Nov. 24, 2006.
 English machine translation of KR1020060118803, published on Nov. 24, 2006.
 English machine translation of KR1020060118802, published on Nov. 24, 2006.
 English machine translation of KR1020060118801, published on Nov. 24, 2006.
 English machine translation of KR1020060118800, published on Nov. 24, 2006.
 English machine translation of KR1020060118795, published on Nov. 24, 2006.
 English machine translation of KR1020060112420, published on Nov. 1, 2006.
 English machine translation of KR1020060018004, Published on Feb. 28, 2006.
 English machine translation of KR1020060008365, published on Jan. 26, 2006.
 English machine translation of KR1020050108623, published on Nov. 17, 2005.
 English machine translation of KR1020050104614, published on Nov. 3, 2005.
 English machine translation of KR1020050104613, published on Nov. 3, 2005.
 English machine translation of KR1020050103343, published on Oct. 31, 2005.
 English machine translation of KR1020050091838, published on Sep. 15, 2005.
 English machine translation of KR1020050091837, published on Sep. 15, 2005.
 English machine translation of KR1020050091836, published on Sep. 15, 2005.
 English machine translation of KR1020050091835, published on Sep. 15, 2005.
 English machine translation of KR1020050091834, published on Sep. 15, 2005.

(56)

References Cited

OTHER PUBLICATIONS

English machine translation of KR1020050091833, published on Sep. 15, 2005.
 English machine translation of KR1020050091830, published on Sep. 15, 2005.
 English machine translation of KR1020050091829, published on Sep. 15, 2005.
 English machine translation of KR1020050091826, published on Sep. 15, 2005.
 English machine translation of KR1020050091824, published on Sep. 15, 2005.
 English machine translation of KR1020050091821, published on Sep. 15, 2005.
 English machine translation of KR1020040088978, published on Oct. 20, 2004.
 English machine translation of KR1020040050174, published on Jun. 16, 2004.
 English machine translation of DE202012101457, published on Aug. 16, 2012.
 English machine translation of DE112012000251, published on Oct. 17, 2013.
 English machine translation of DE112011104642, published on Oct. 2, 2013.
 English machine translation of DE112007001314, published on Apr. 23, 2009.
 English machine translation of DE102007011457, published on Oct. 25, 2007.
 English machine translation of DE102005015004, published on Feb. 7, 2008.
 English machine translation of DE102005014541, published on Aug. 28, 2008.
 English machine translation of DE102005008278, published on Mar. 27, 2008.
 English machine translation of DE102004055192, published on Nov. 15, 2007.
 English machine translation of JP2010227287, published on Oct. 14, 2010.
 English machine translation of JP2006272019, published on Oct. 12, 2006.
 English machine translation of CN202277306, published on Jun. 20, 2012.
 English machine translation of CN201131706, published on Oct. 15, 2008.

English machine translation of CN201008534, published on Jan. 23, 2008.
 English machine translation of CN103040413, published on Apr. 17, 2013.
 English machine translation of CN103040412, published on Apr. 17, 2013.
 English machine translation of CN102256523, published on Nov. 5, 2014.
 English machine translation of CN101822506, published on Sep. 8, 2010.
 English machine translation of CN101612025, published on Dec. 30, 2009.
 International Search Report and Written Opinion, received in connection to international patent application No. PCT/CA2013/000121, mailed on.
 Abstract of the Japanese Patent Application No. JP03176019A, as received in connection to International patent application No. PCT/CA2013/000121.
 TotalPatent: English machine translation of CN101288572; published on Oct. 22, 2008.
 TotalPatent: English machine translation of CN101108110, published on Jan. 23, 2008.
 TotalPatent: English machine translation of CN101108106; published on Jan. 23, 2008.
 TotalPatent: English machine translation of CN100998484, published on Jul. 18, 2007.
 TotalPatent: English machine translation of DE69907201, published on Feb. 5, 2004.
 TotalPatent: English machine translation of DE60116336, published on Aug. 31, 2006.
 TotalPatent: English machine translation of DE10360002; published on Dec. 16, 2004.
 TotalPatent: English machine translation of DE10110581, published on Nov. 13, 2003.
 TotalPatent: English machine translation of JP03176019, published on Jul. 31, 1991.
 TotalPatent: English machine translation of CN1626025, published on Jun. 15, 2005.
 Total Patent: English machine translation of CN1506016, published on Jun. 23, 2005.
 International Search Report which issued in connection to co-pending International Patent Application No. PCT/CA2019/050736, dated Jul. 24, 2019.

* cited by examiner

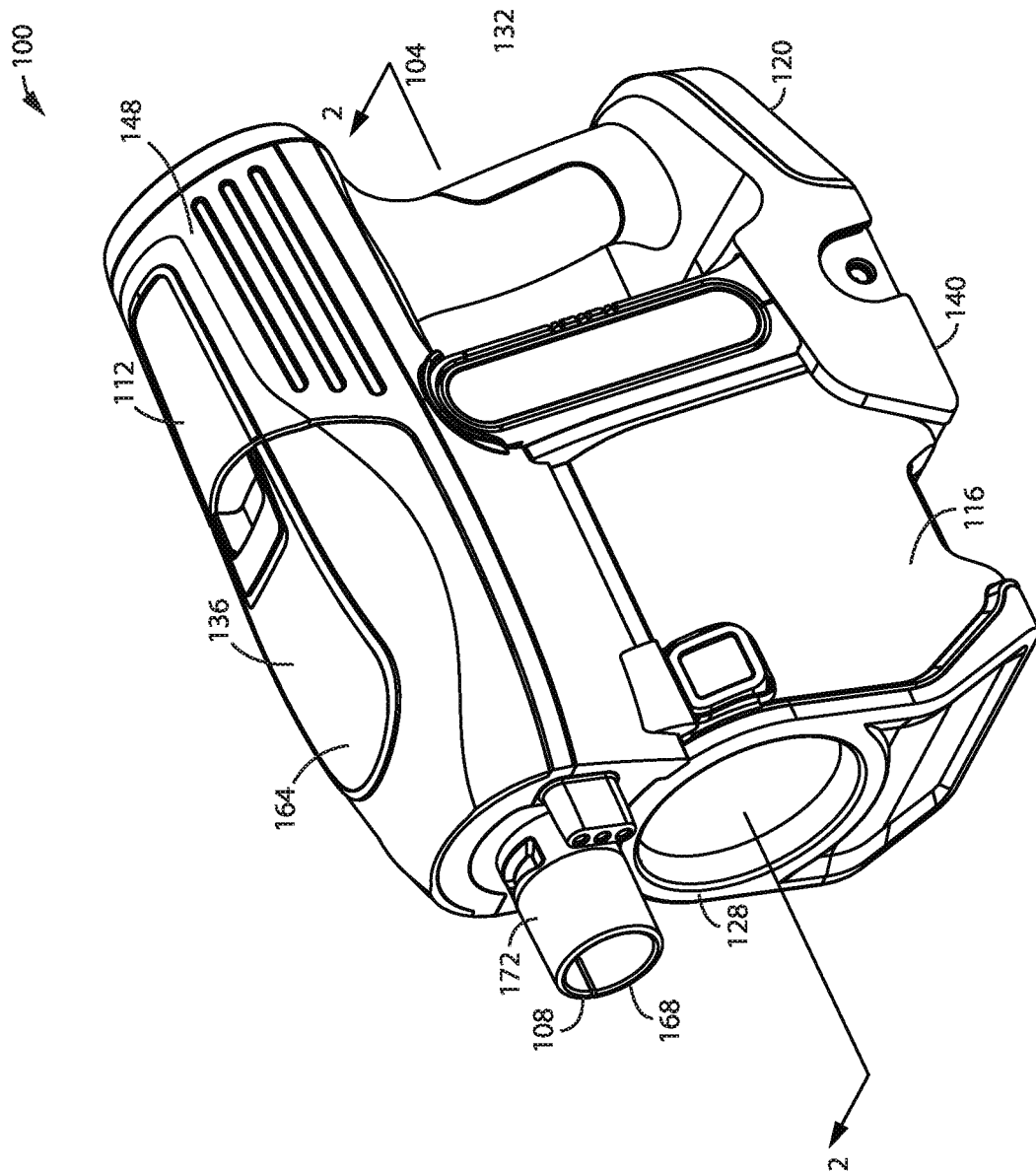

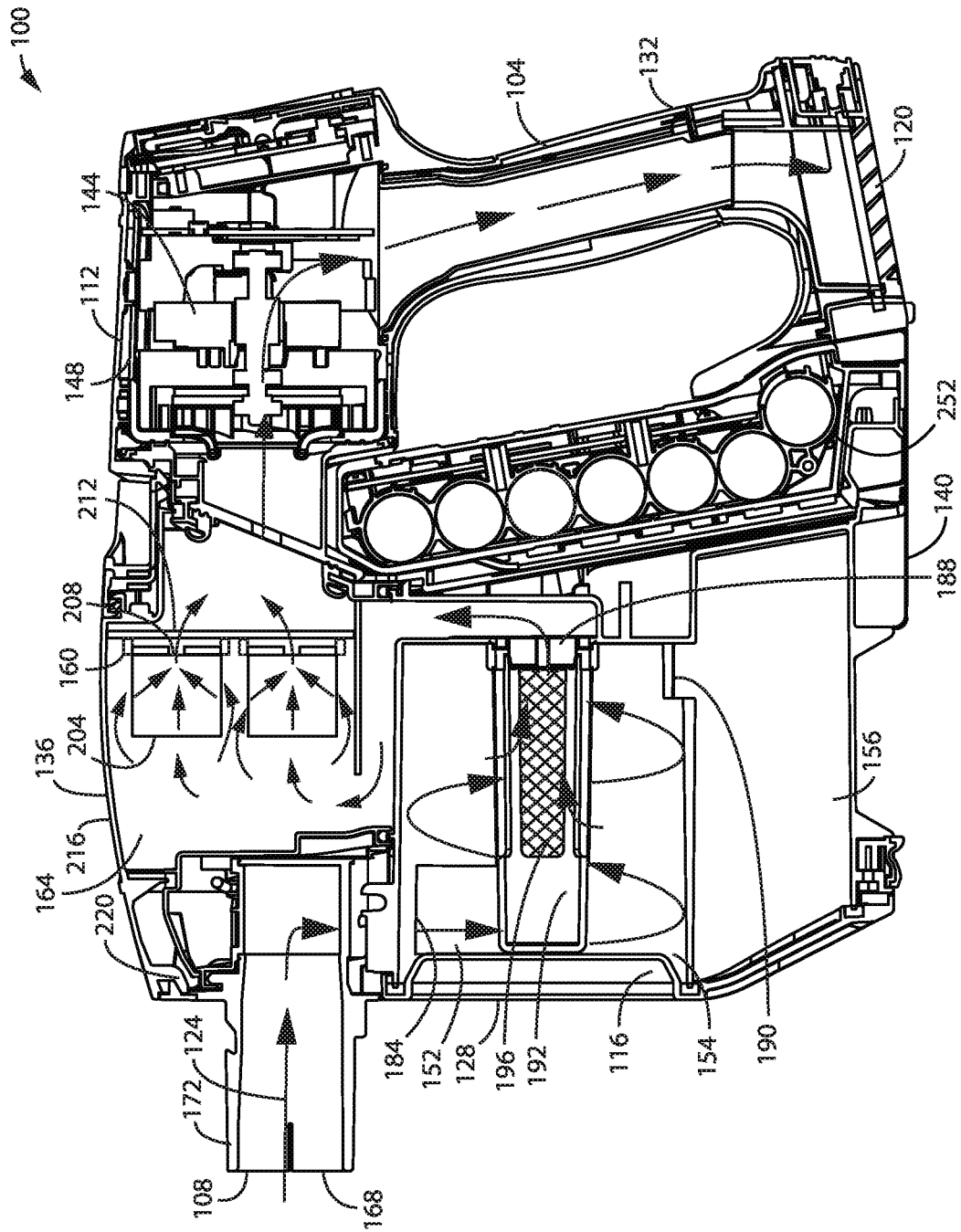

FIG. 2

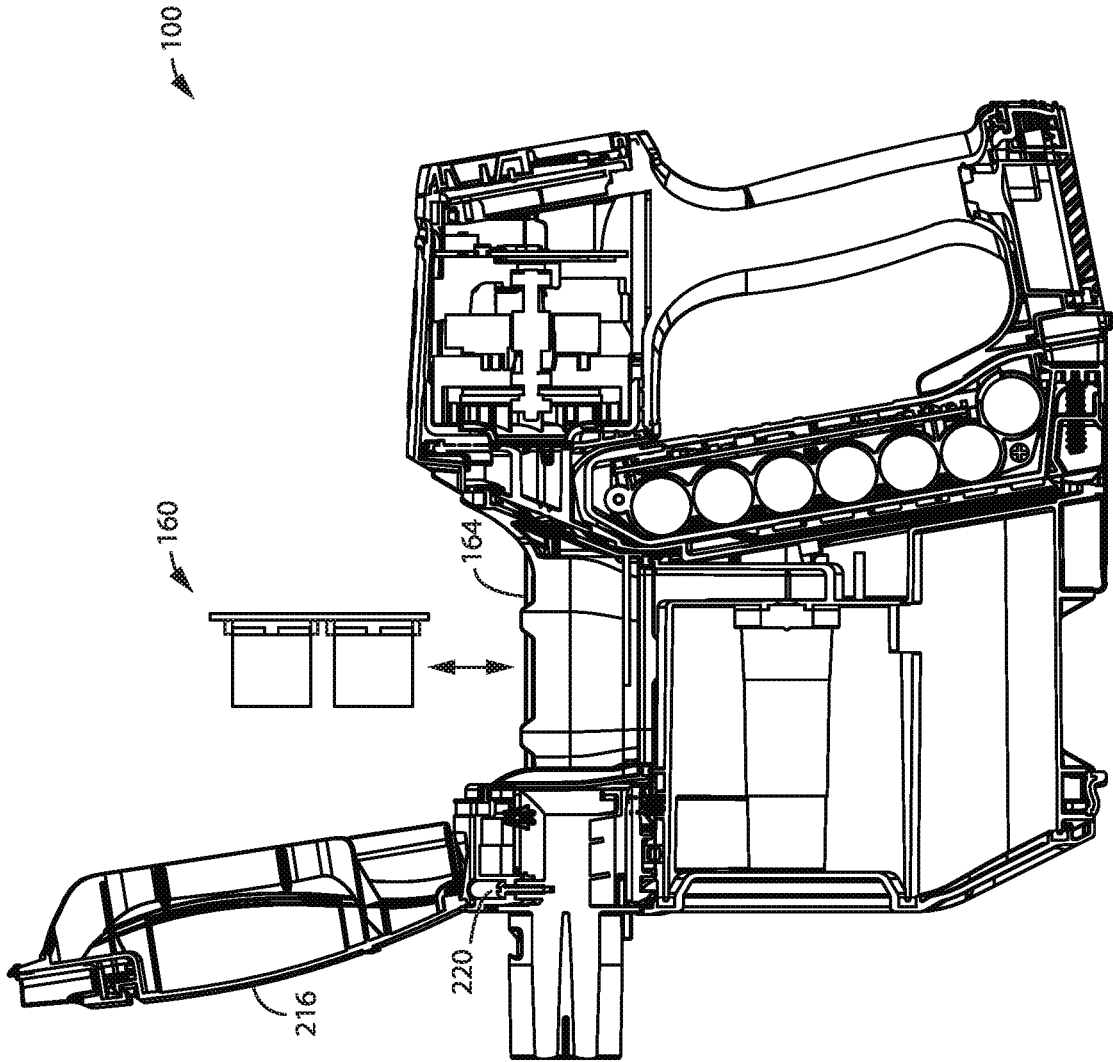

FIG. 3

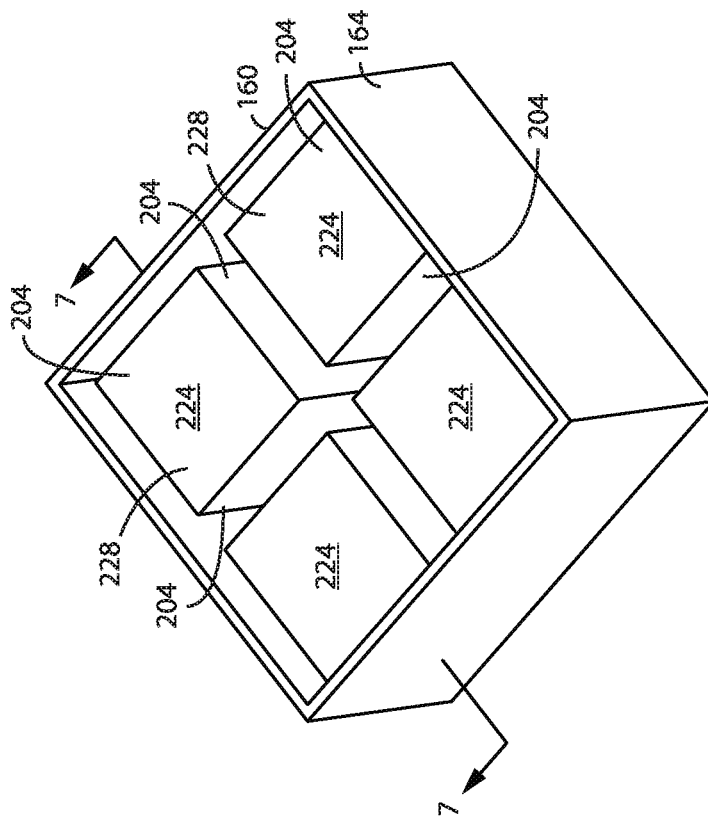

FIG. 4

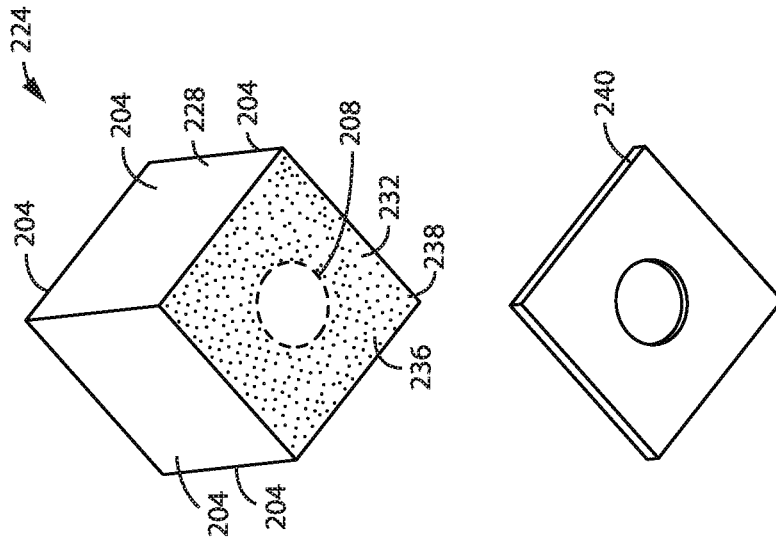

FIG. 5A

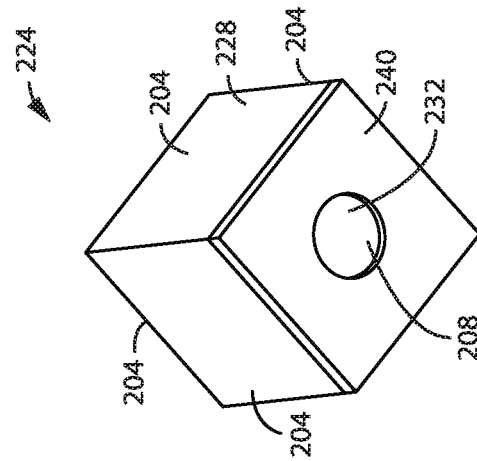

FIG. 5B

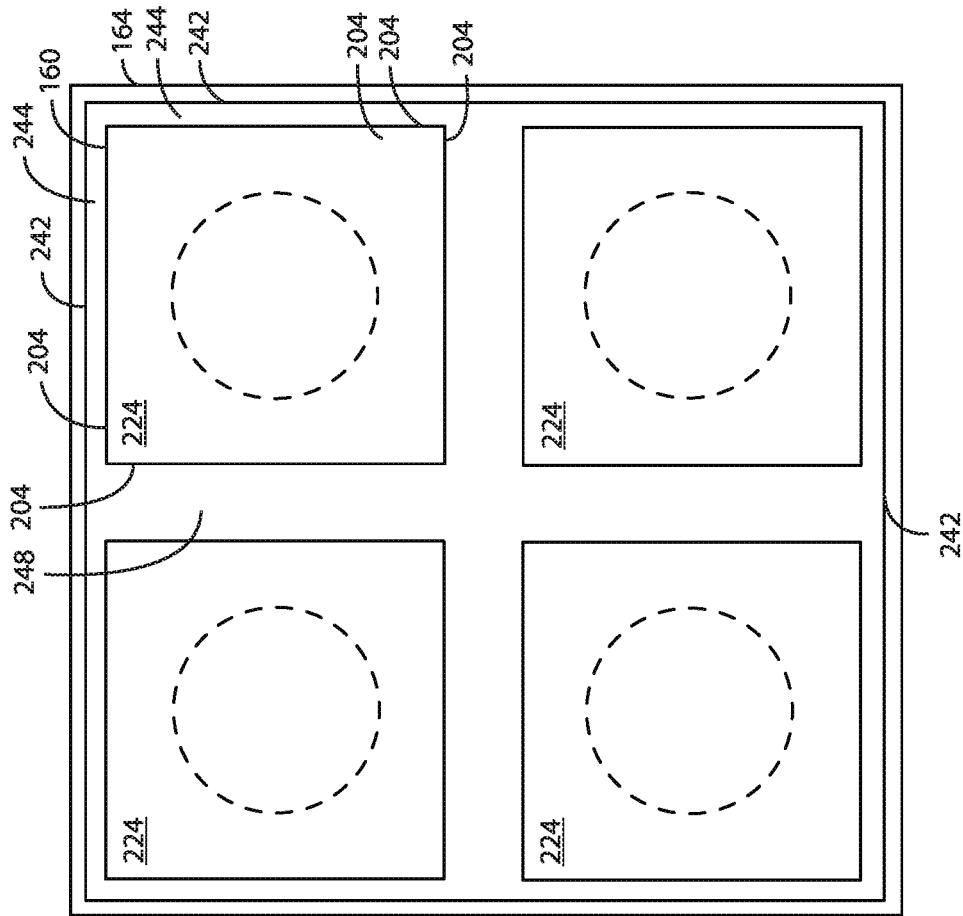

FIG. 6

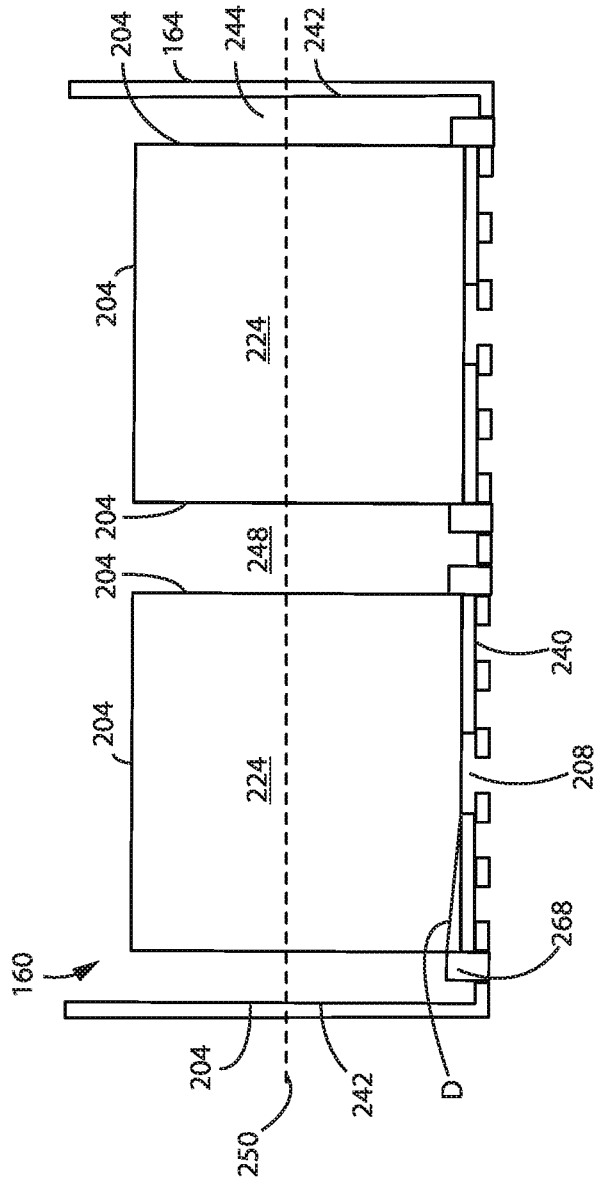

FIG. 7

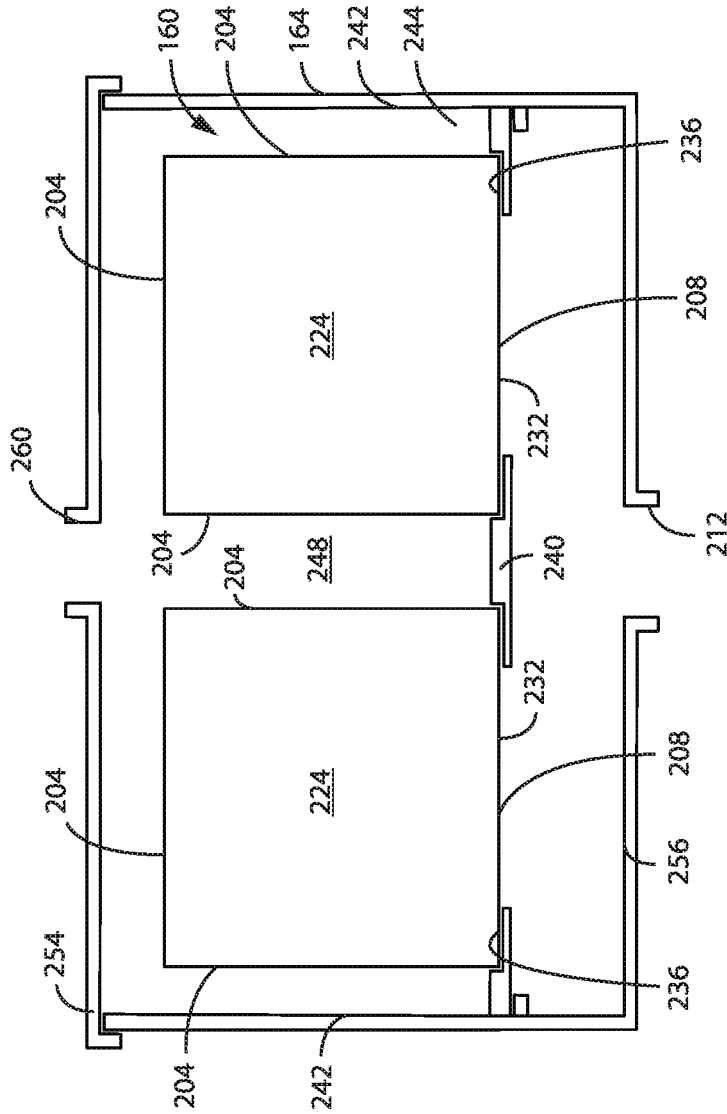

FIG. 8

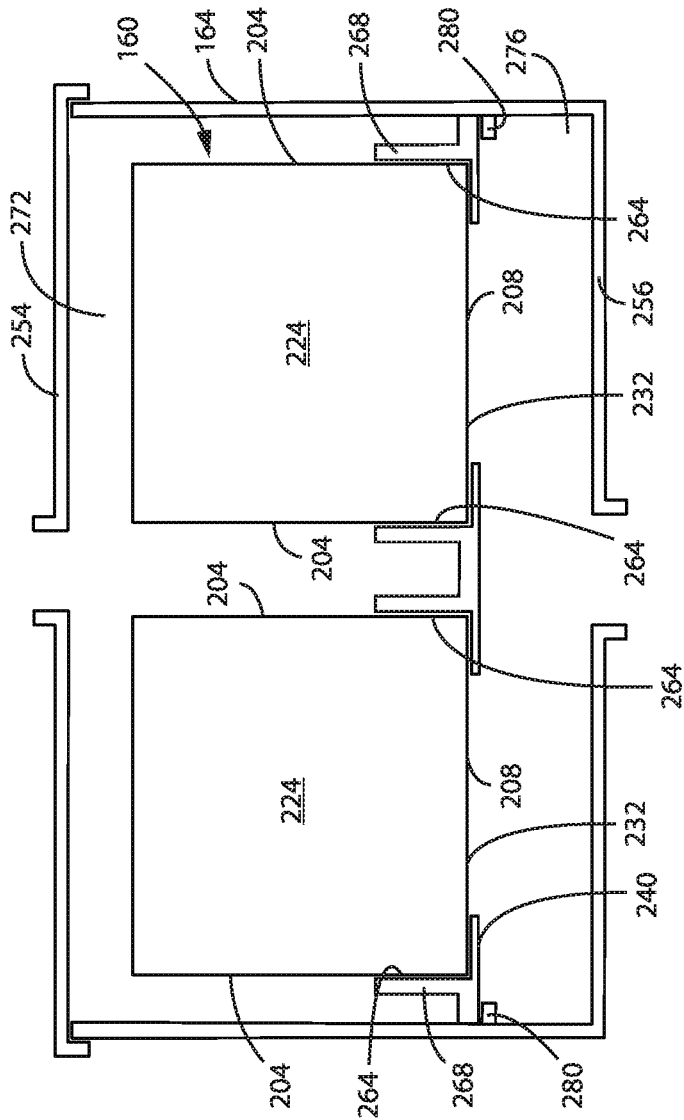

FIG. 9

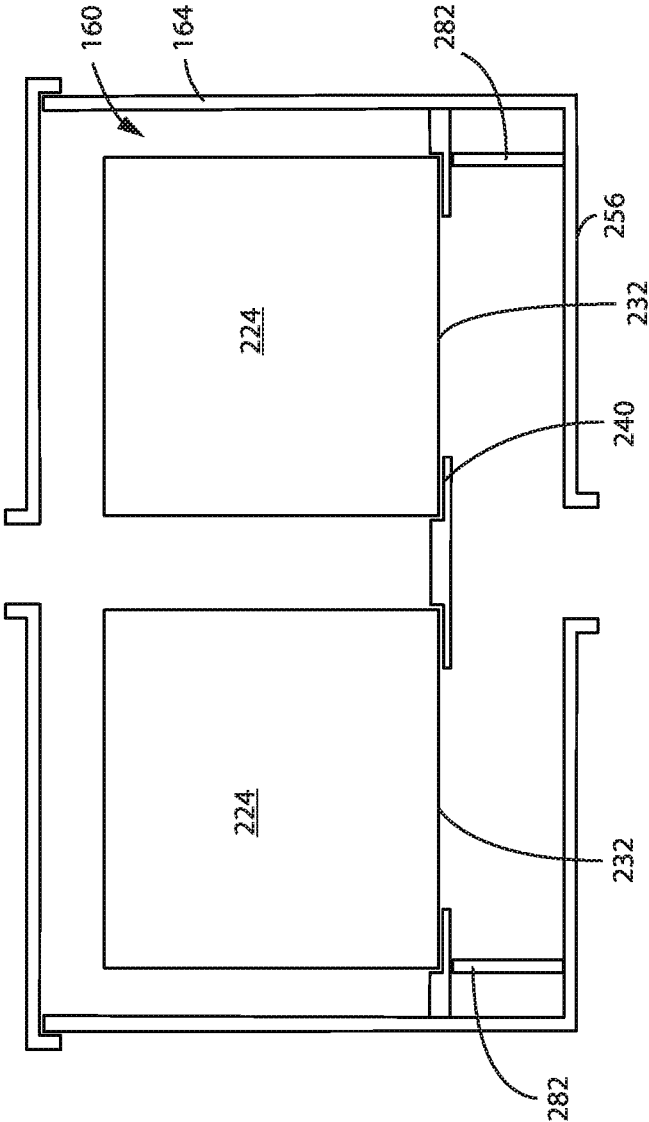

FIG. 10

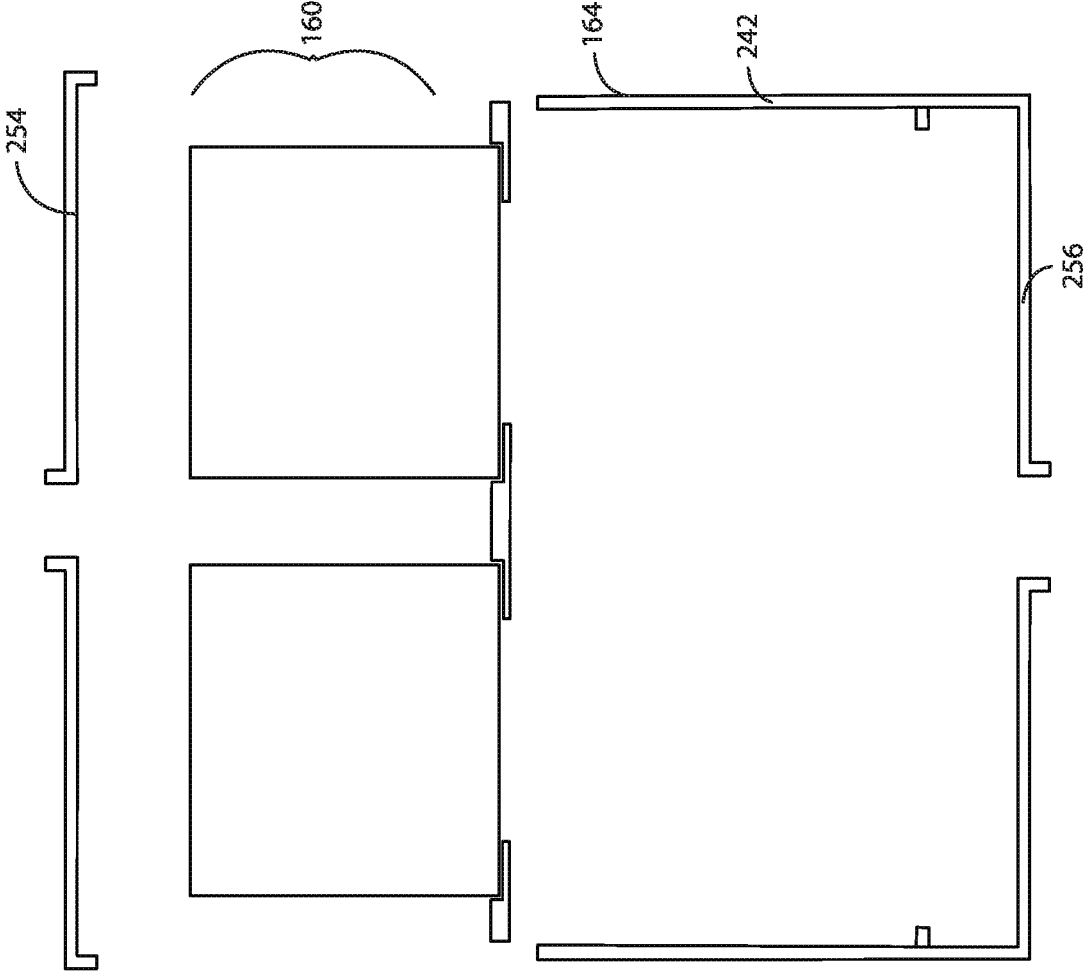

FIG. 11

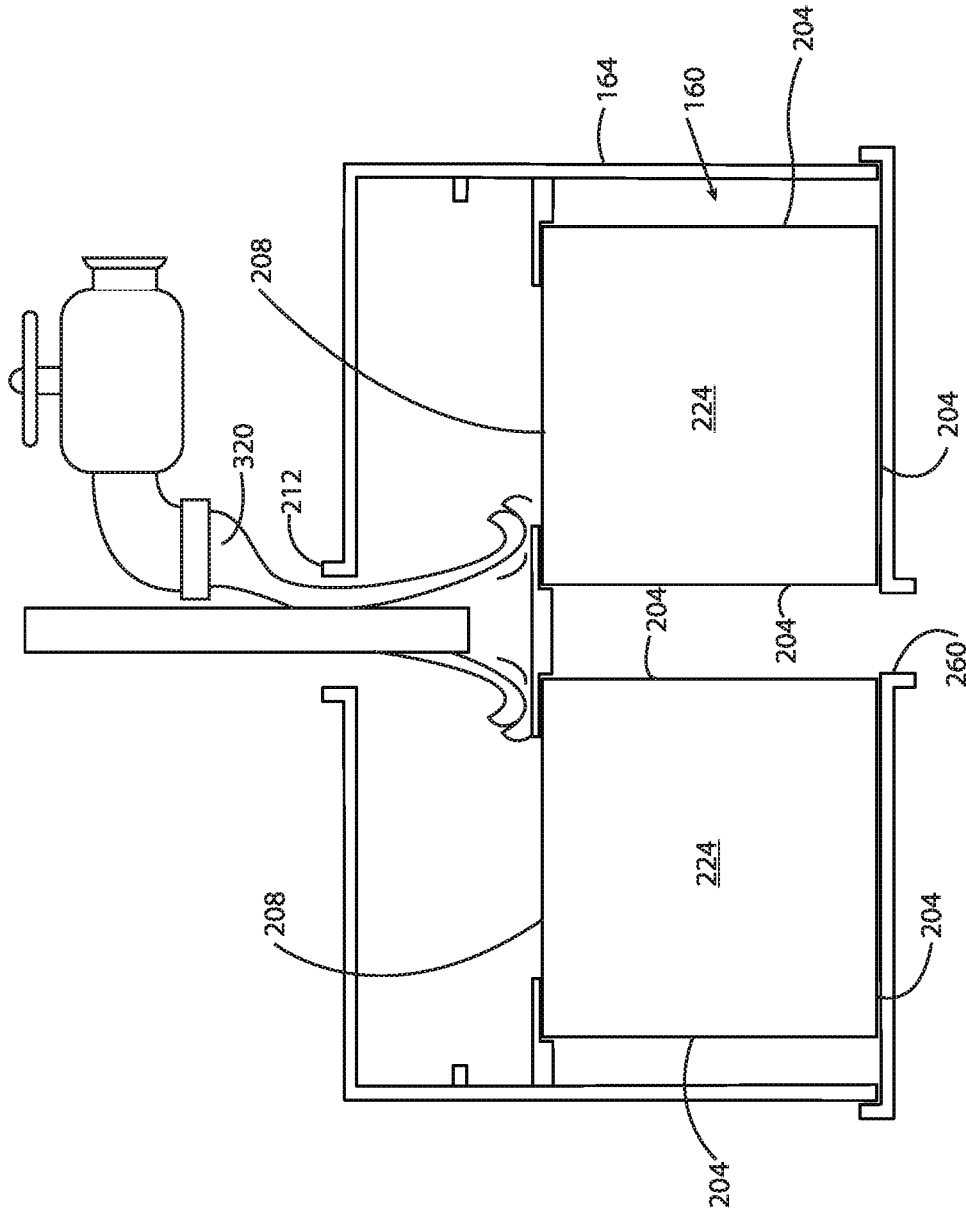

FIG. 12

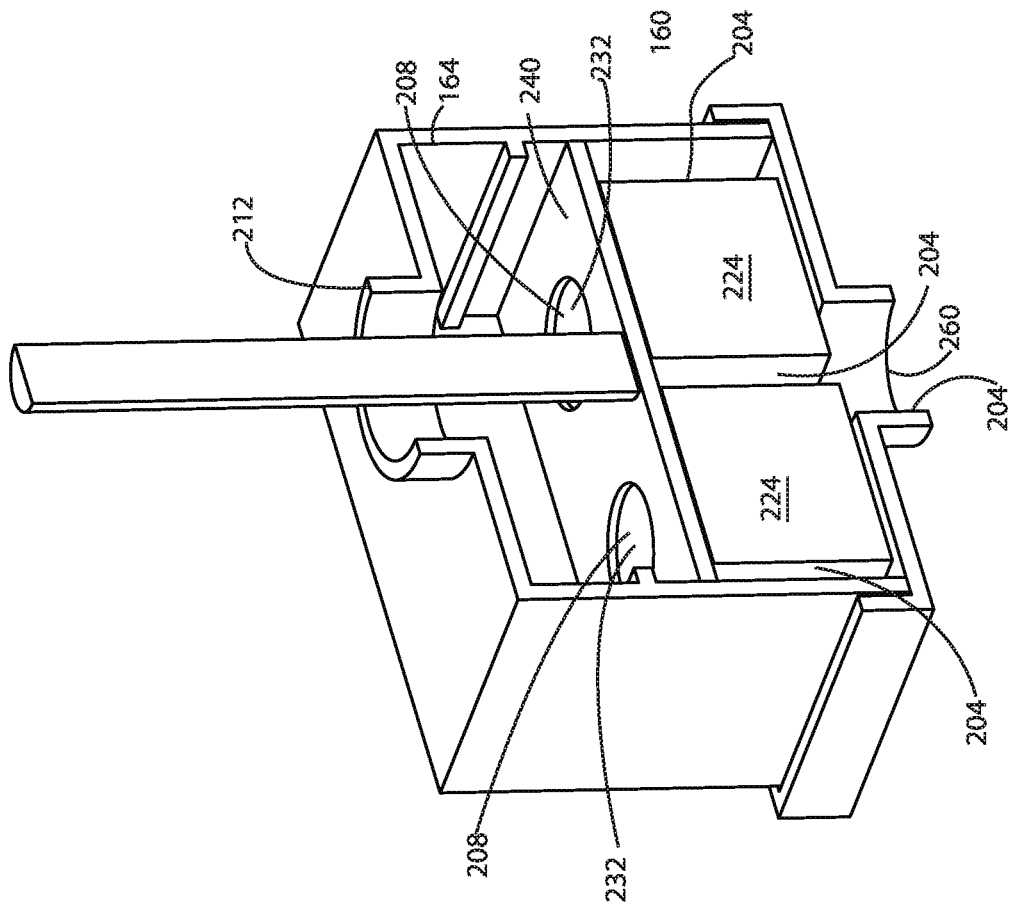

FIG. 13

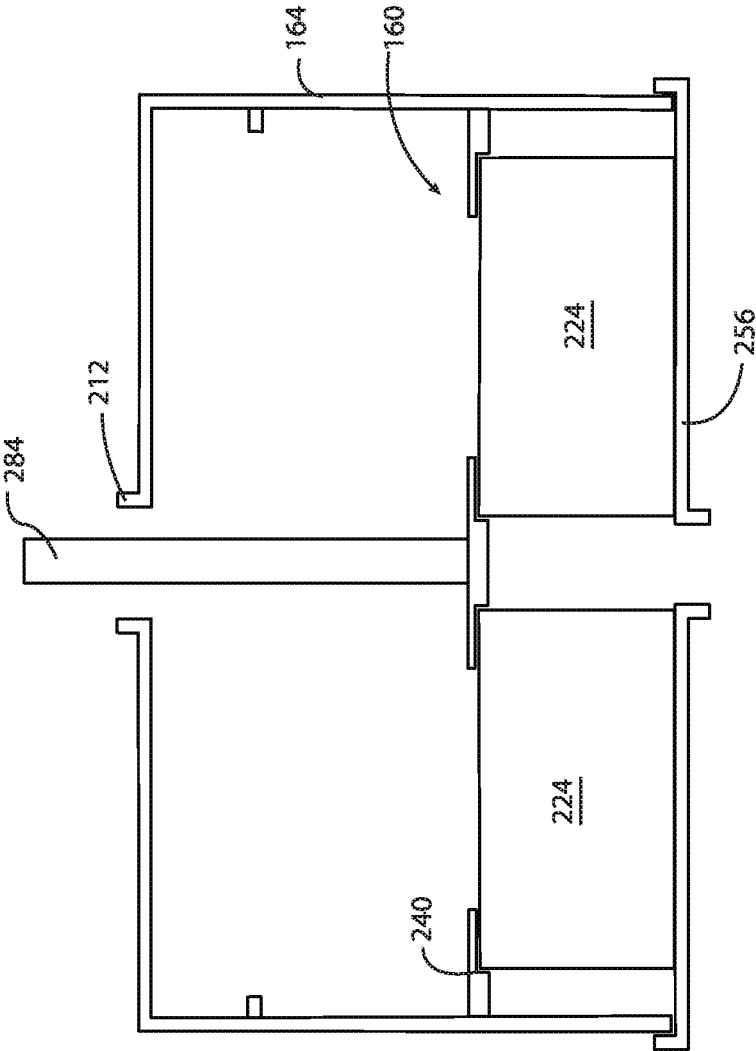

FIG. 14

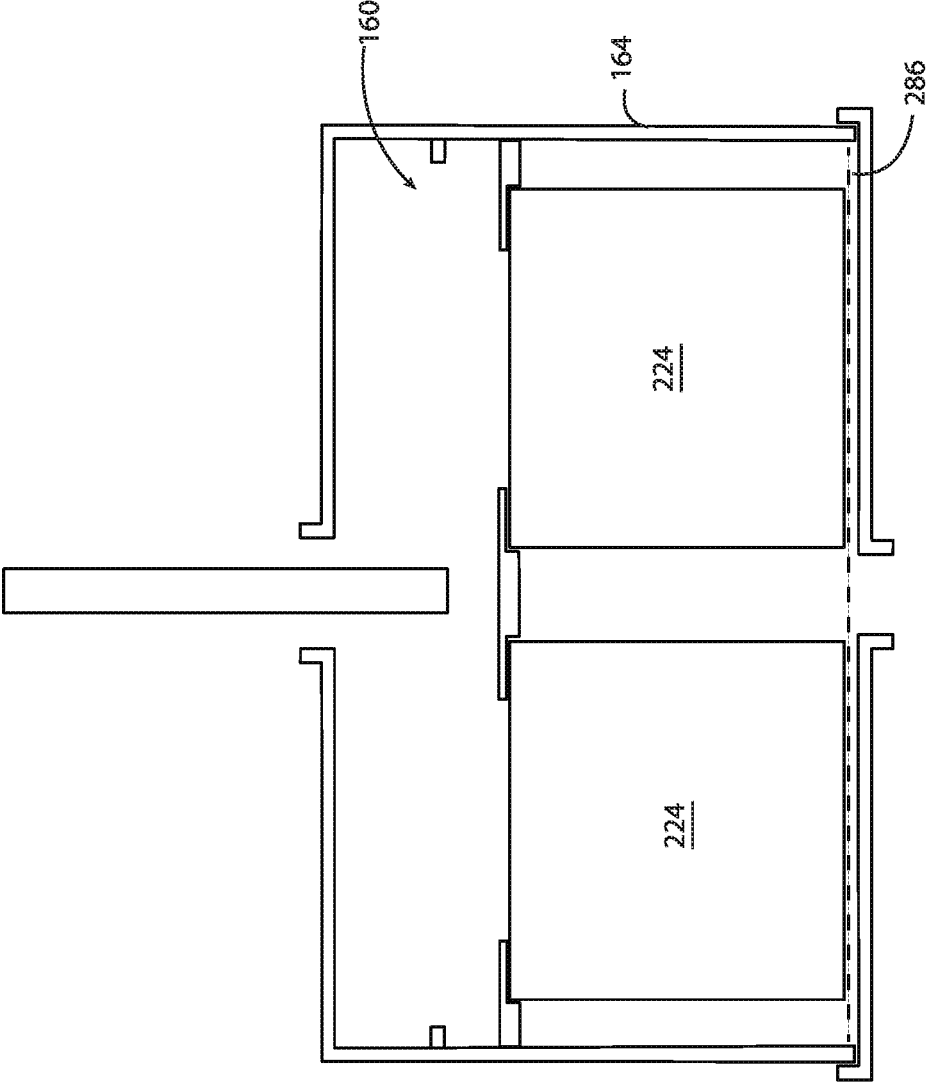

FIG. 15

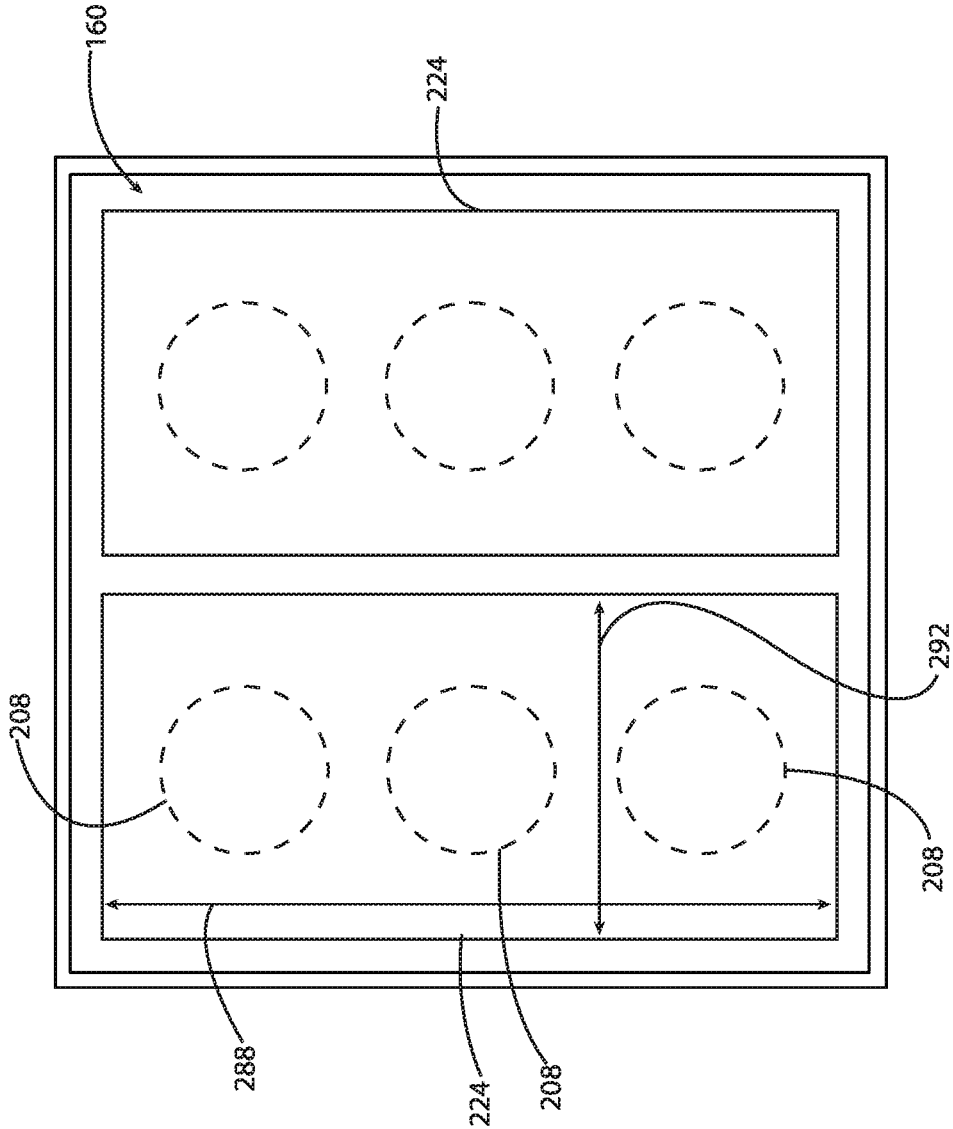

FIG. 16

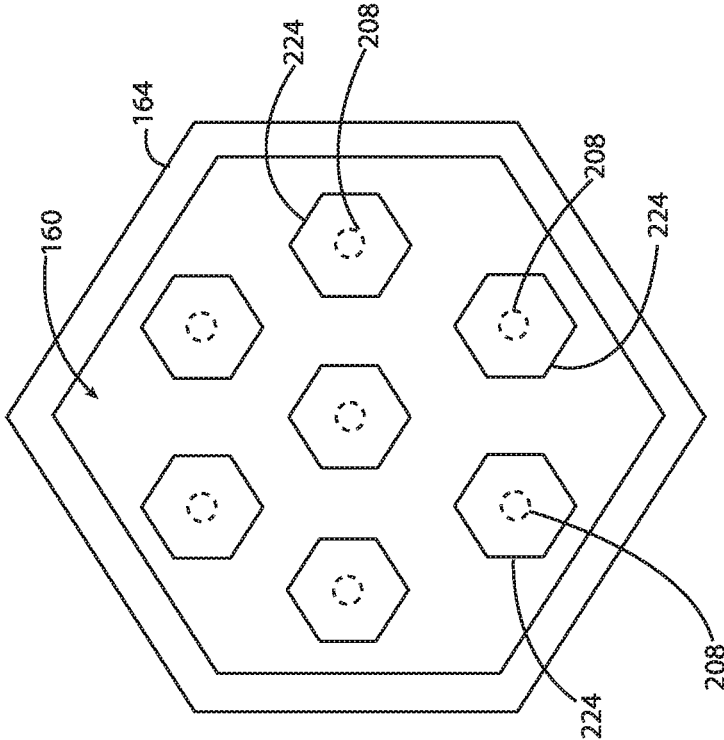

FIG. 17

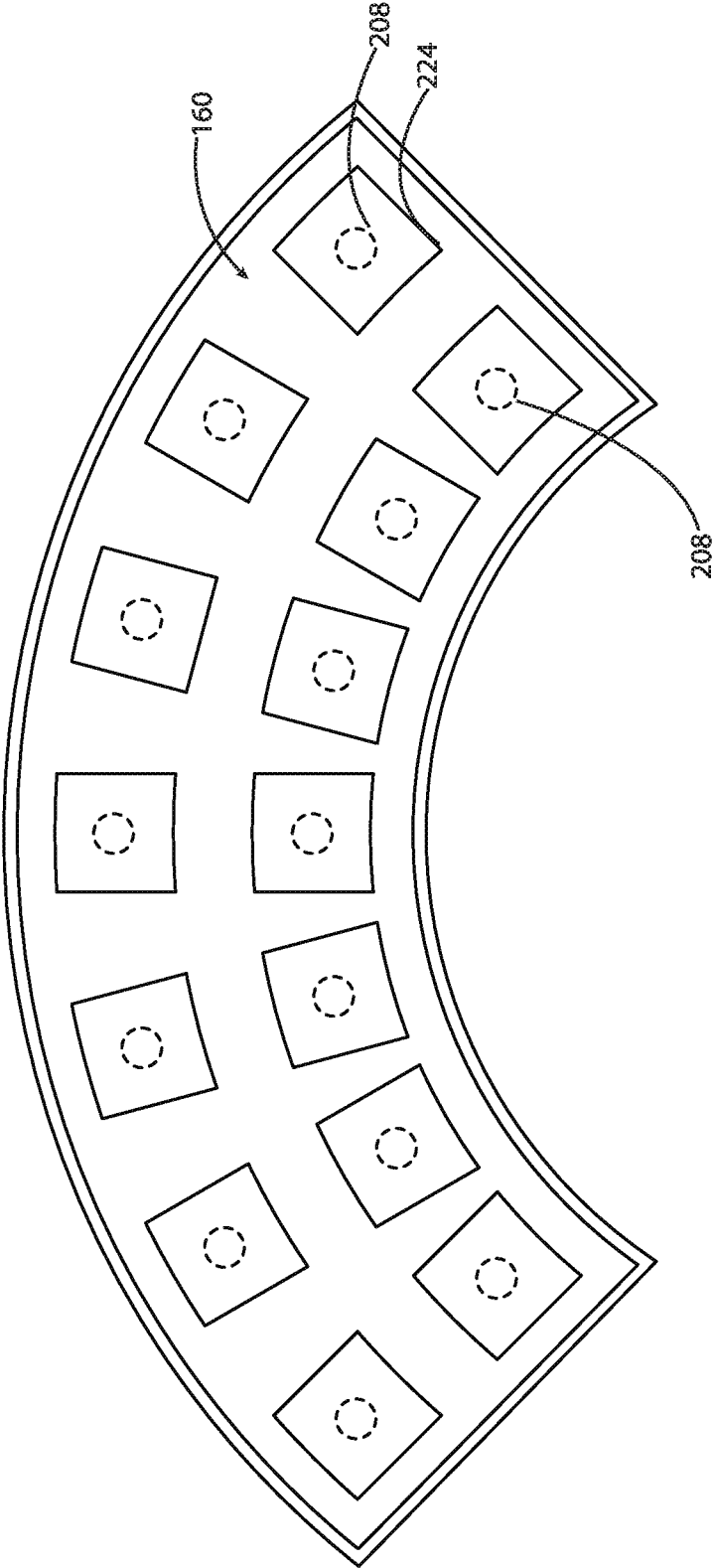

FIG. 18

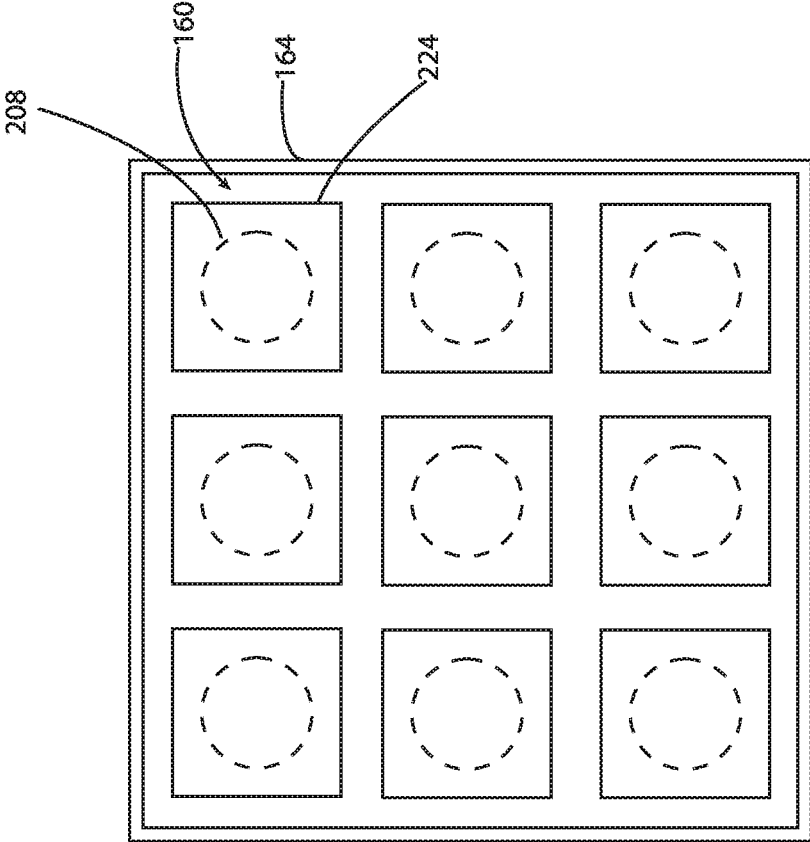

FIG. 19

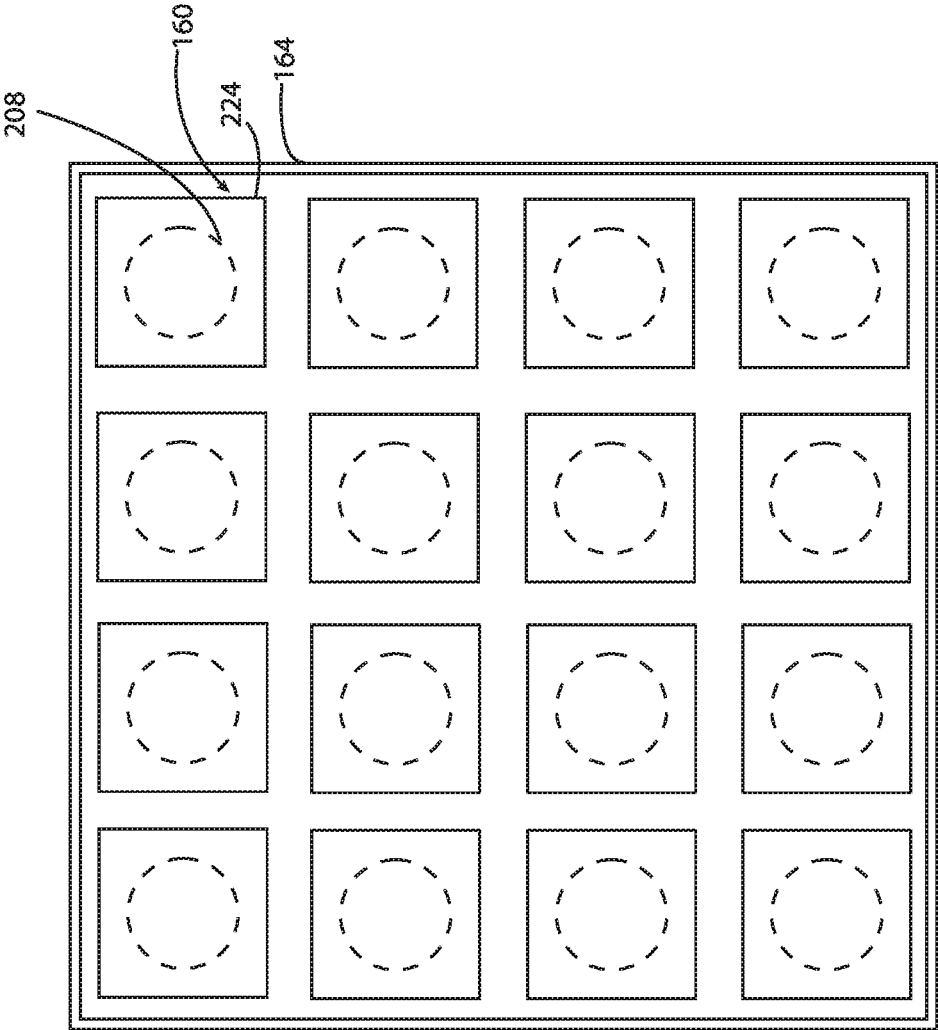

FIG. 20

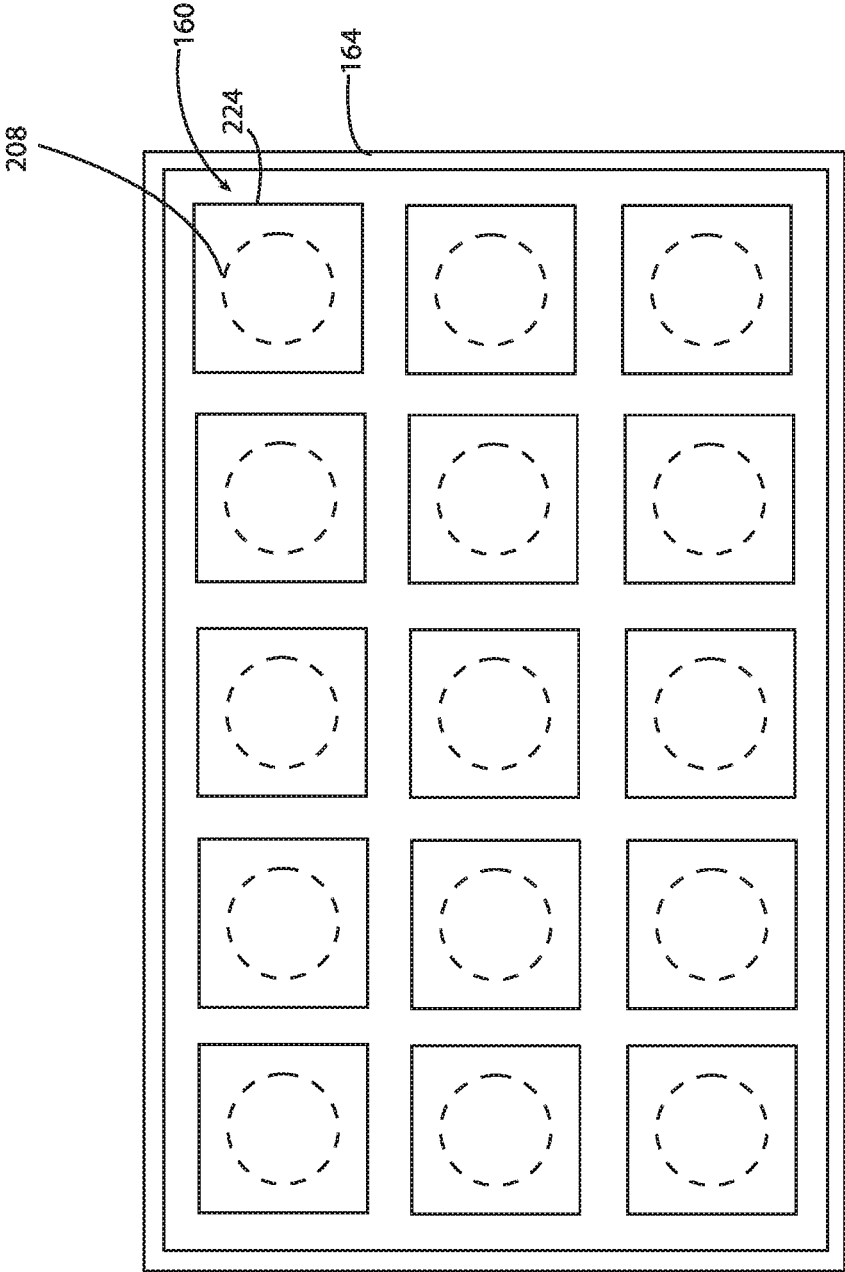

FIG. 21

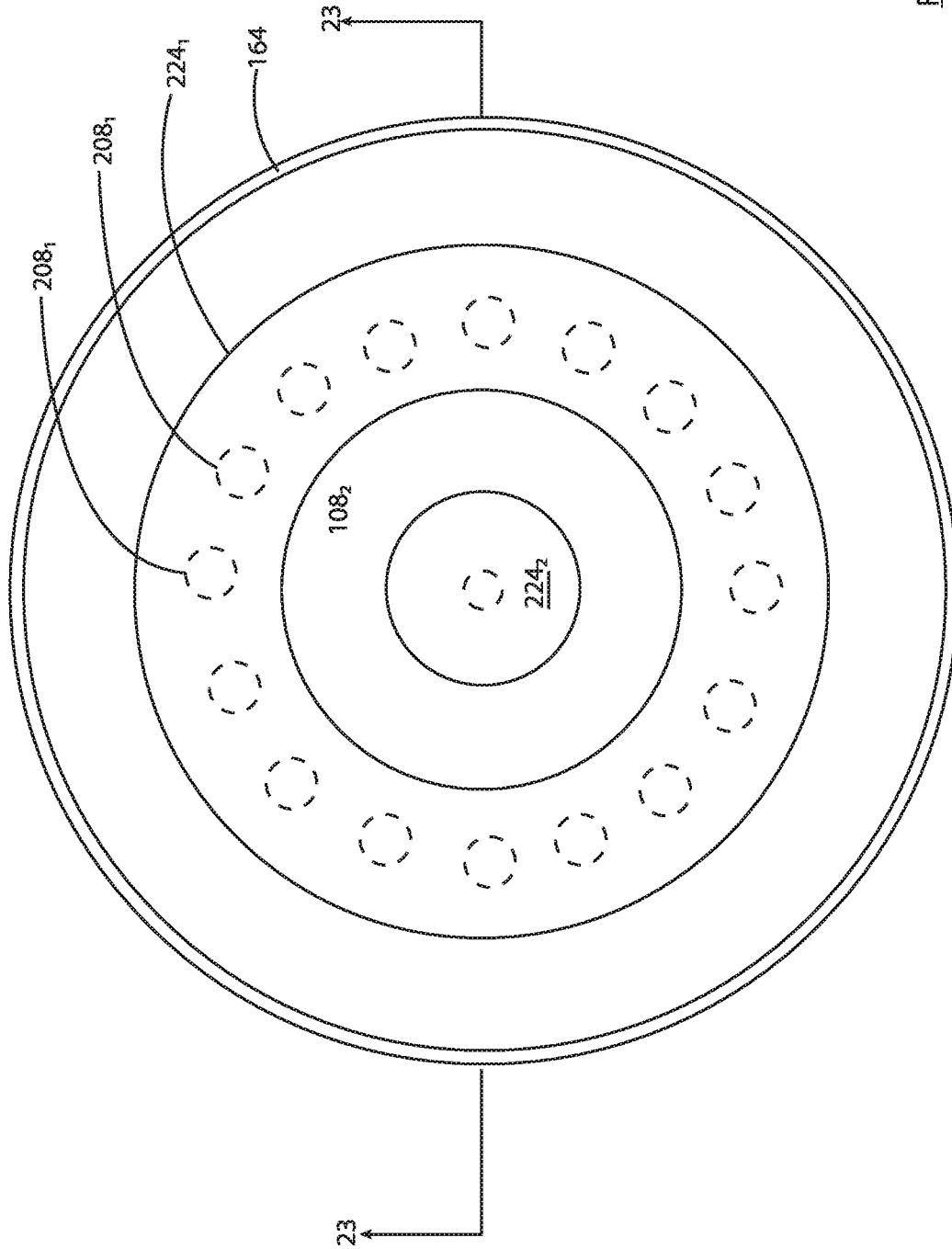

FIG. 22

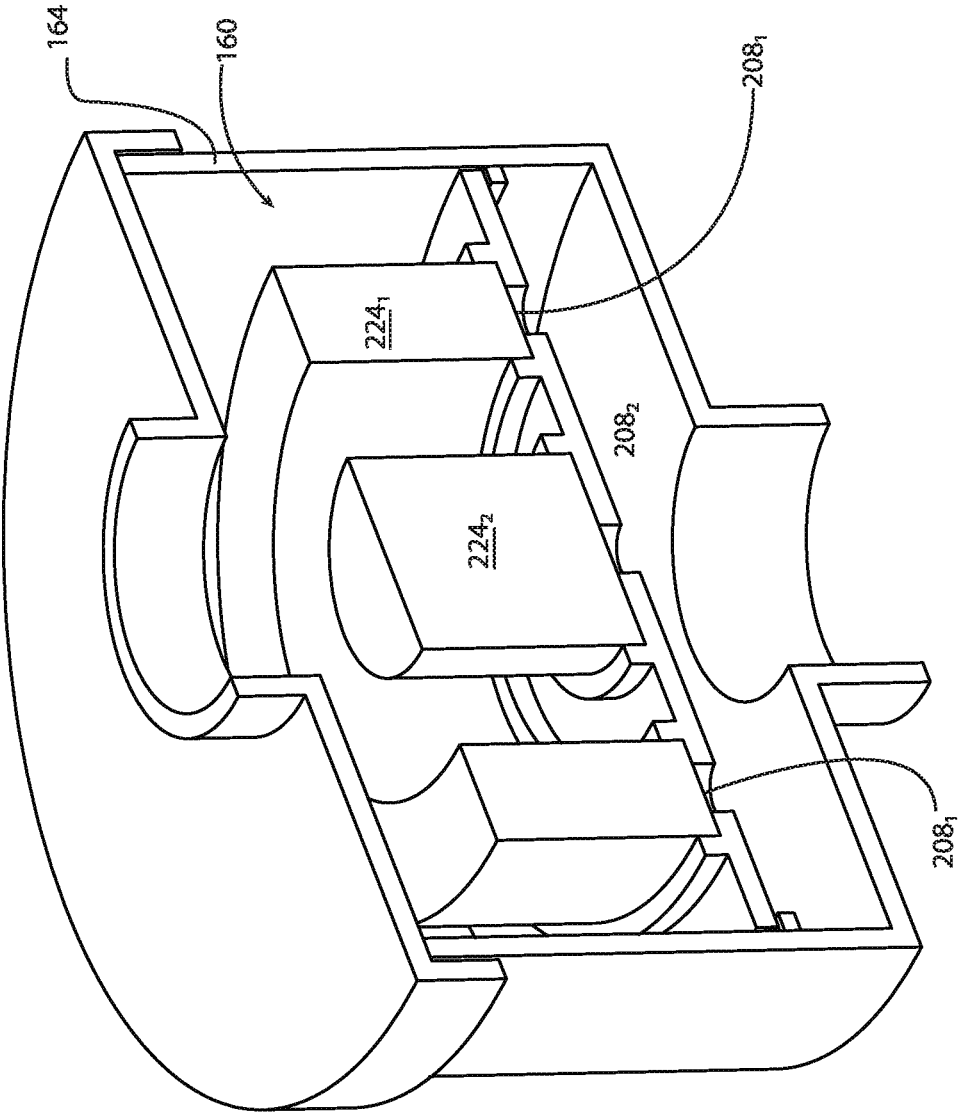

FIG. 23

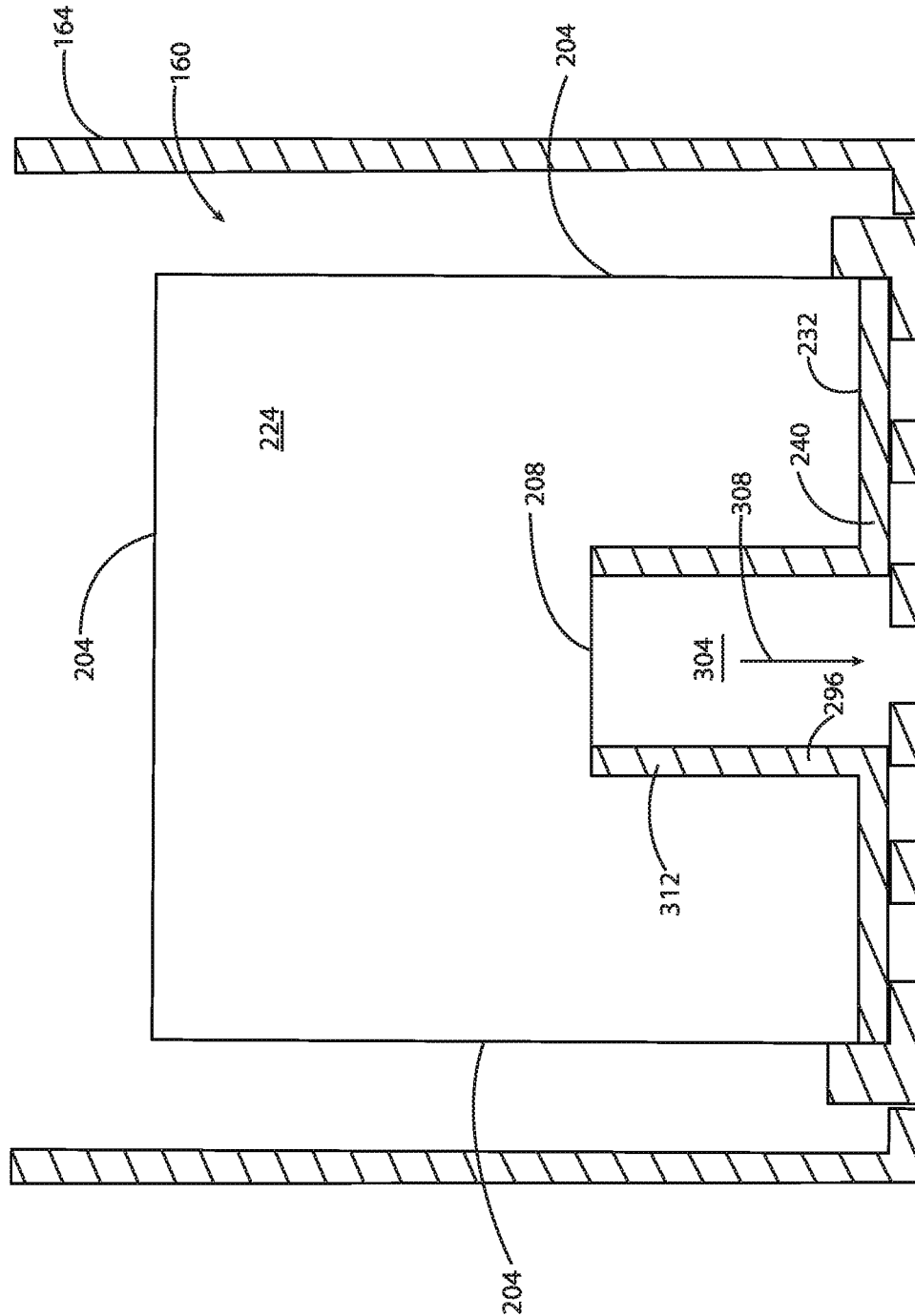

FIG. 24

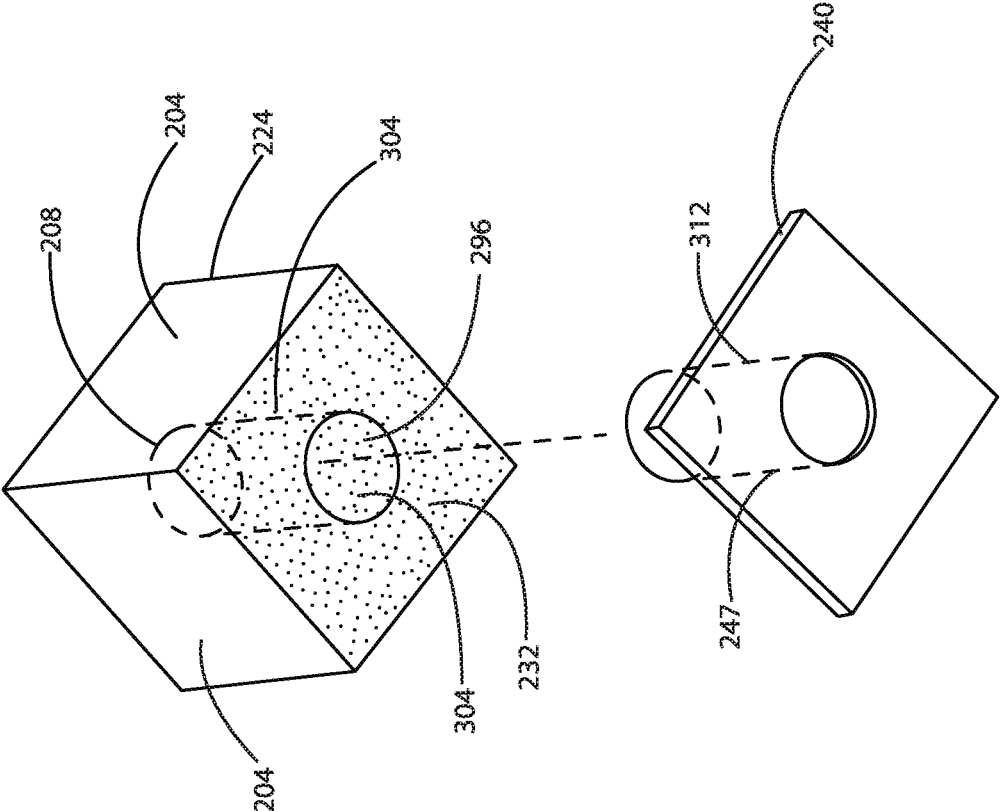

FIG. 25

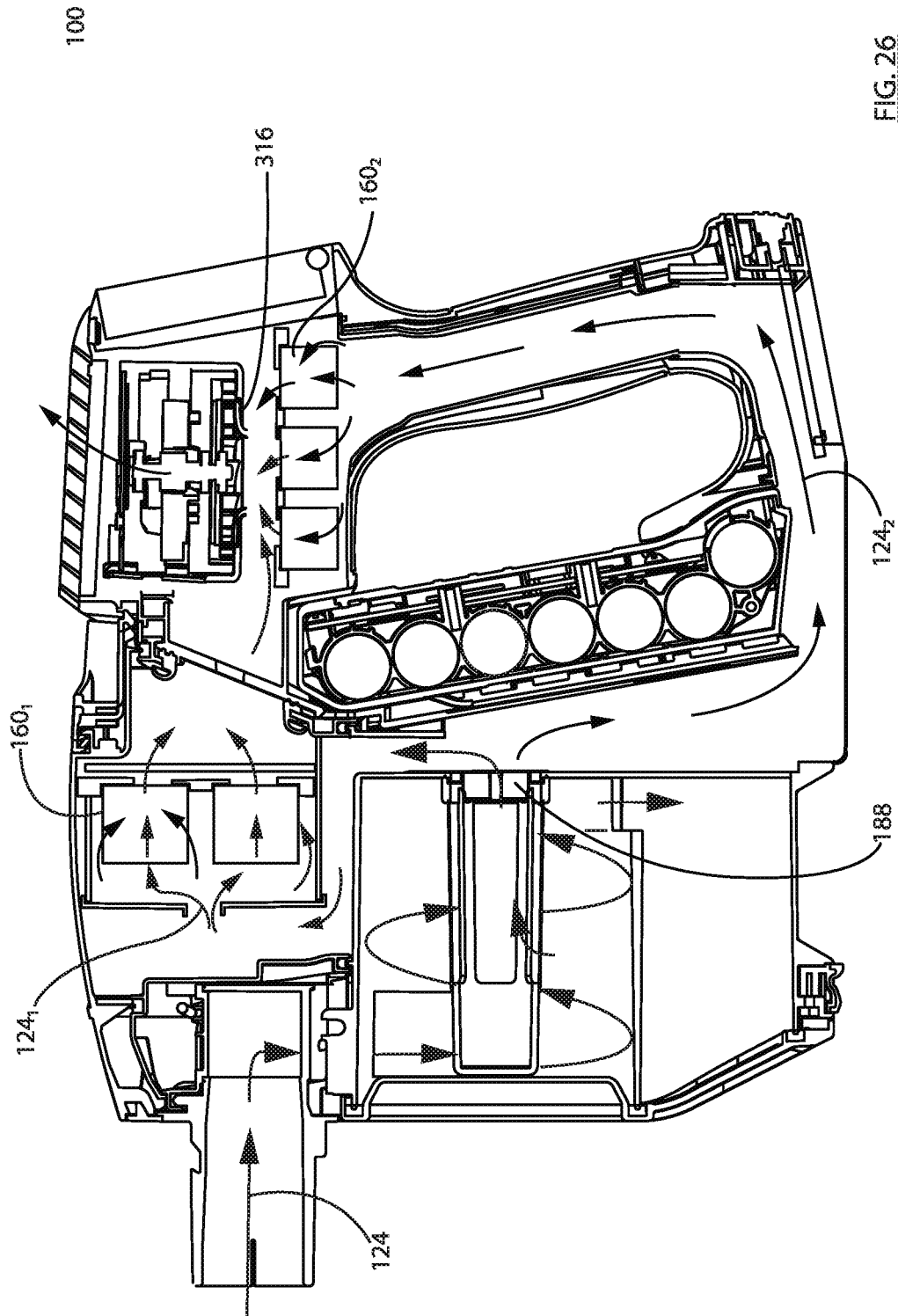

FIG. 26

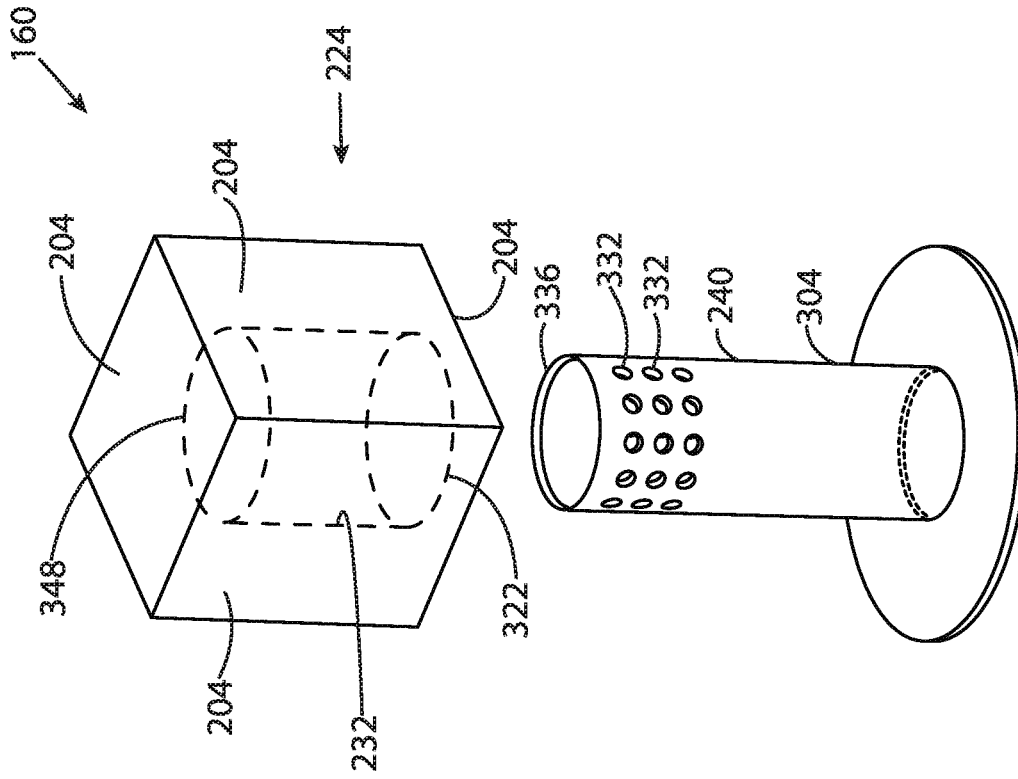

FIG. 27

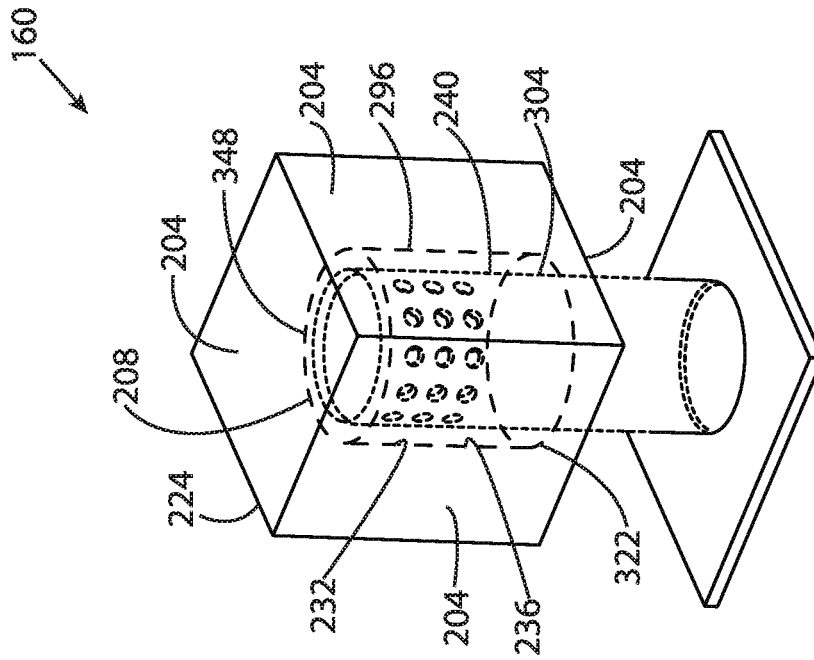

FIG. 28

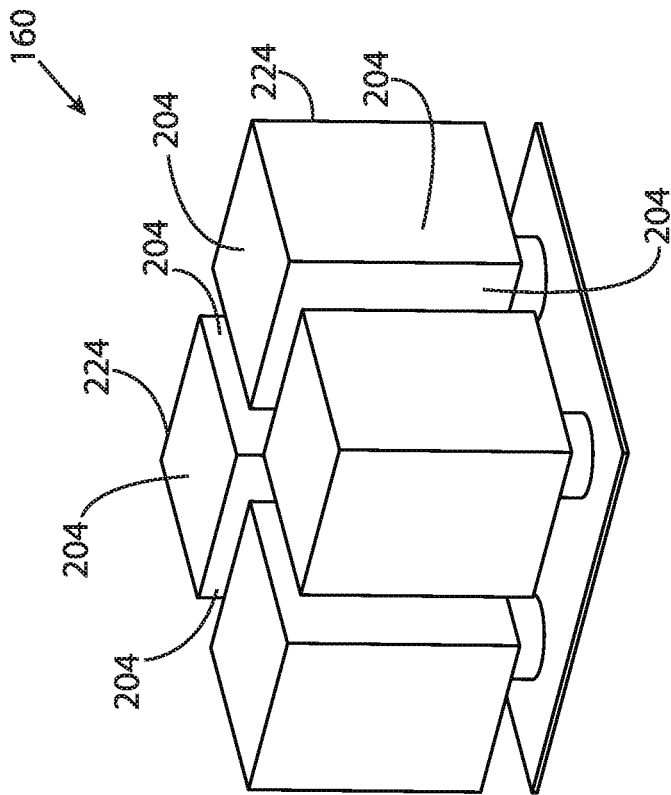
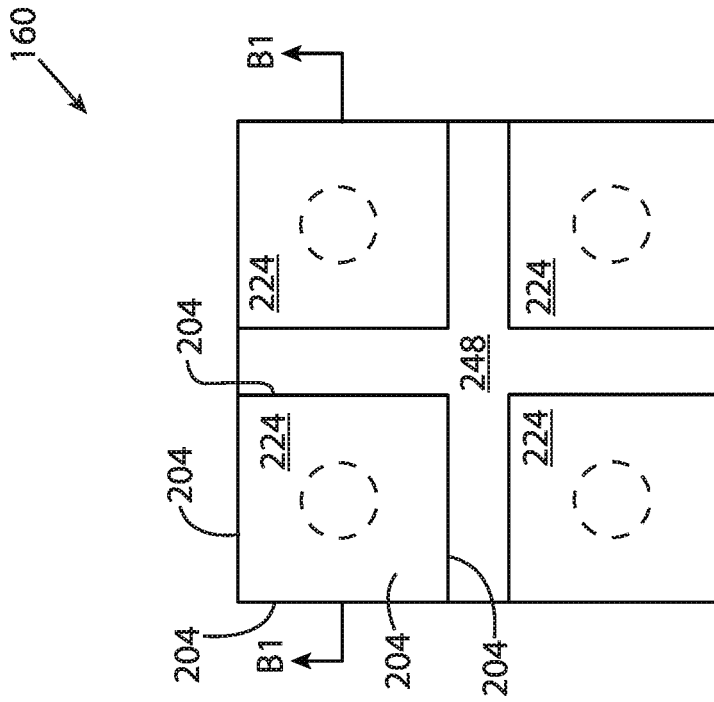

FIG. 29

FIG. 30

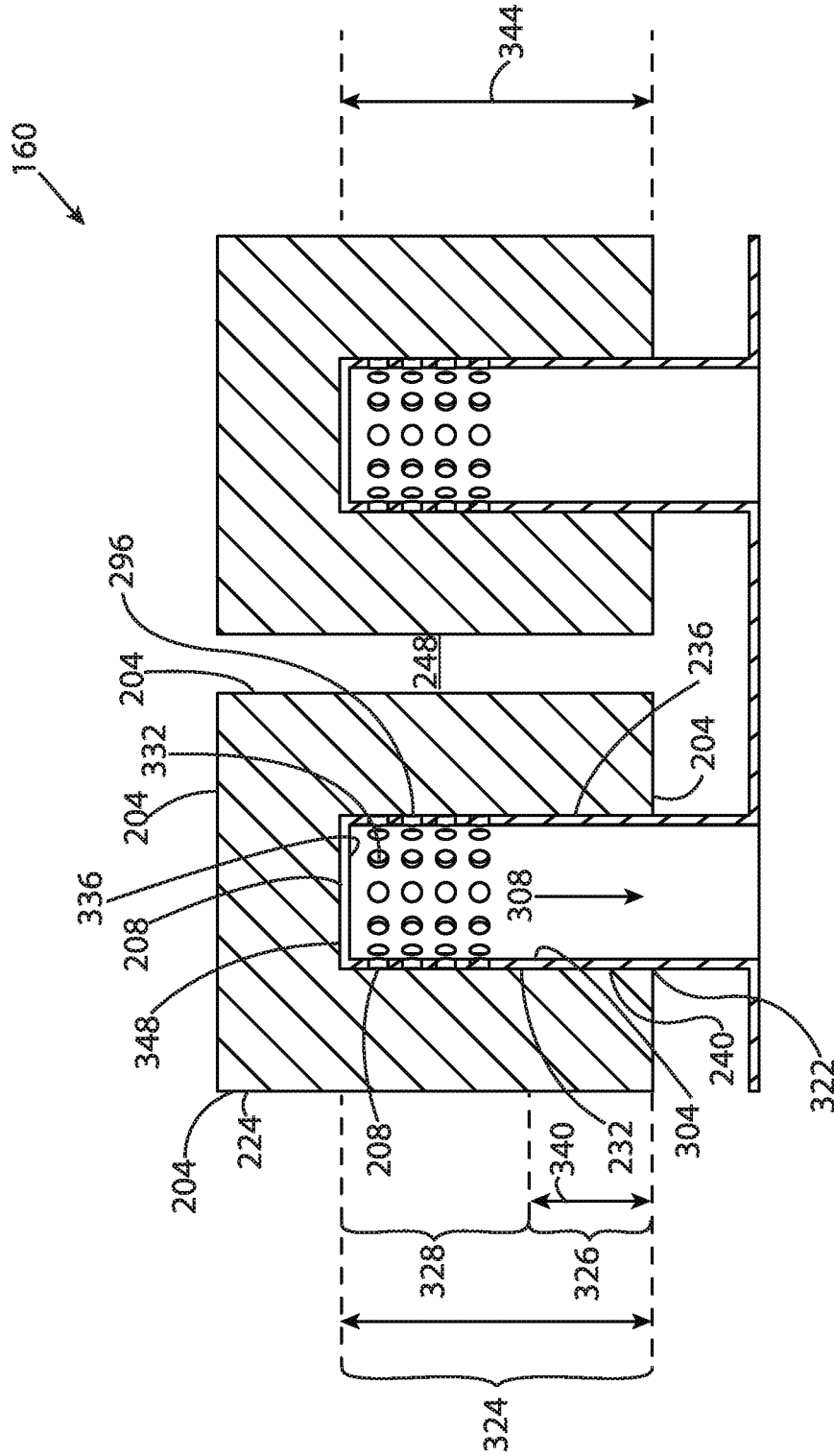

FIG. 31

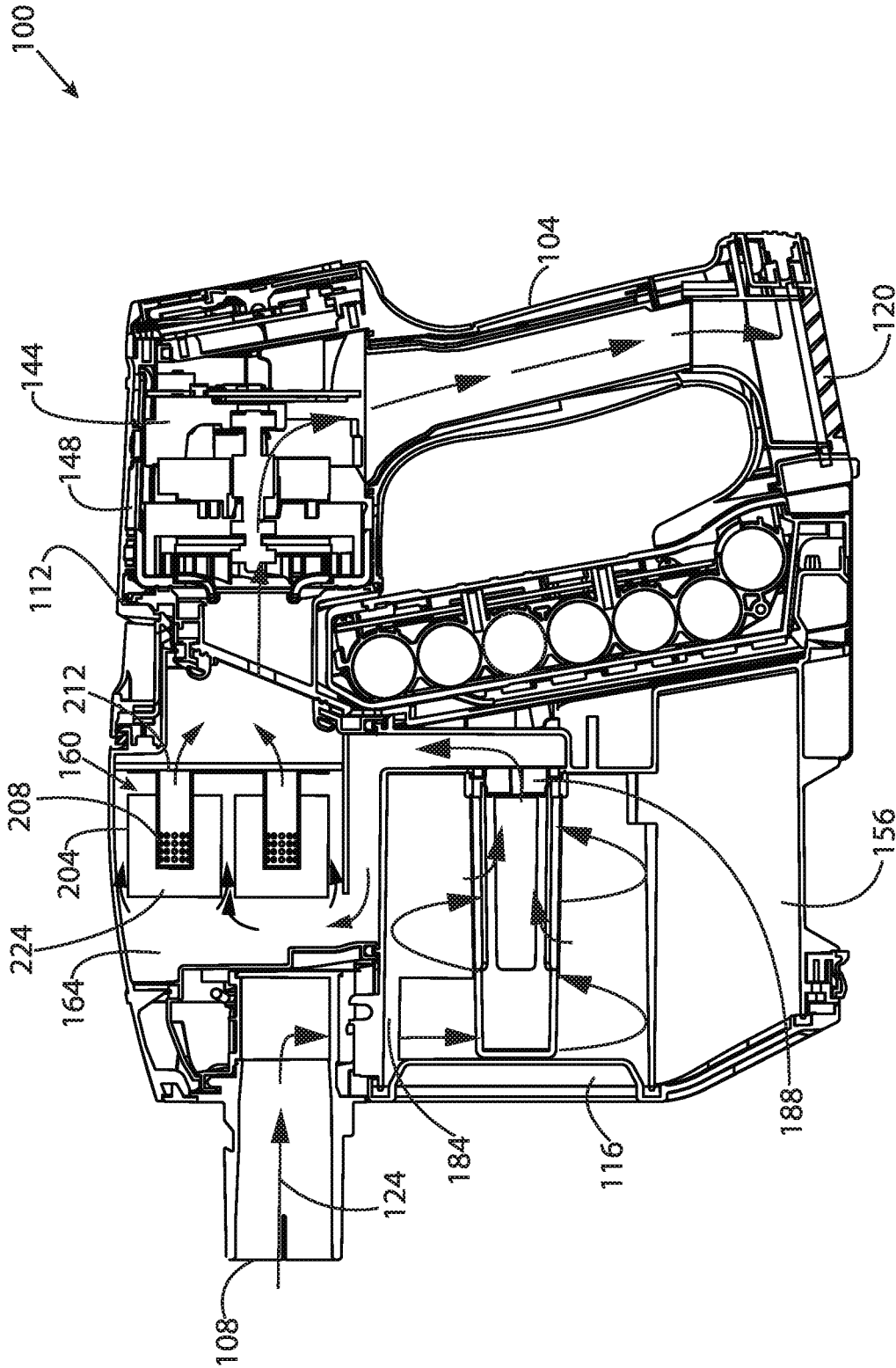

FIG. 32

100

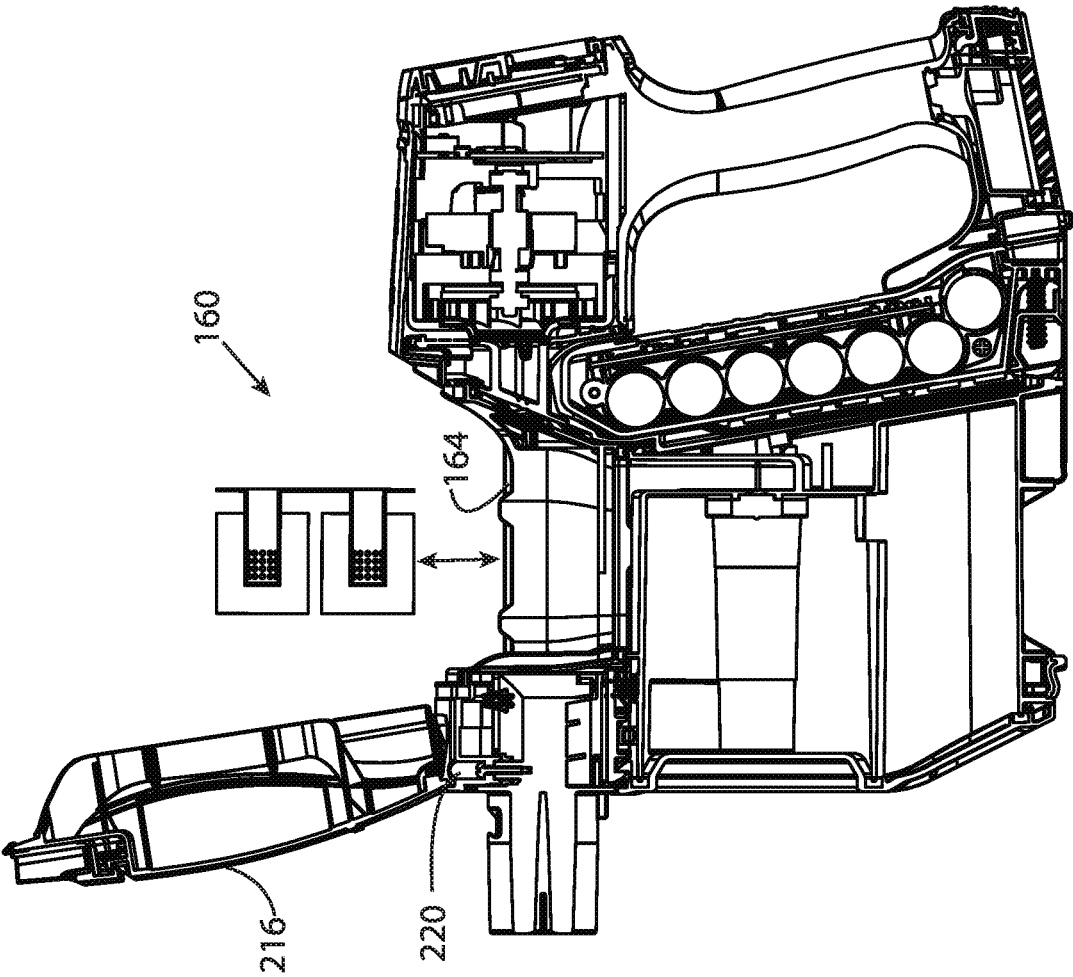

FIG. 33

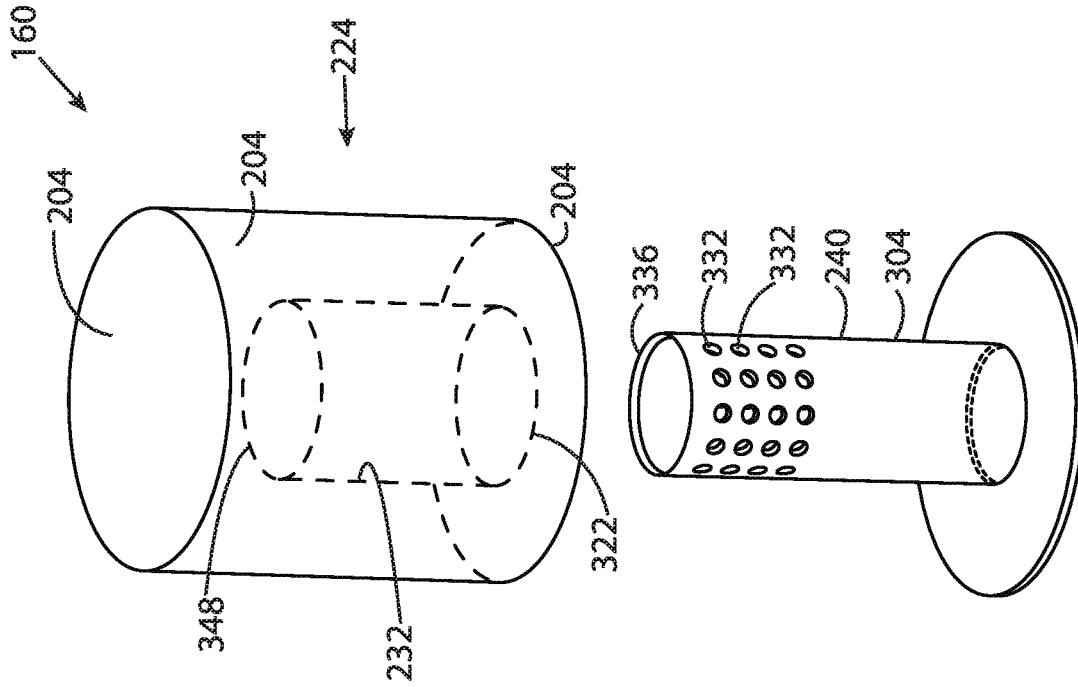

FIG. 35

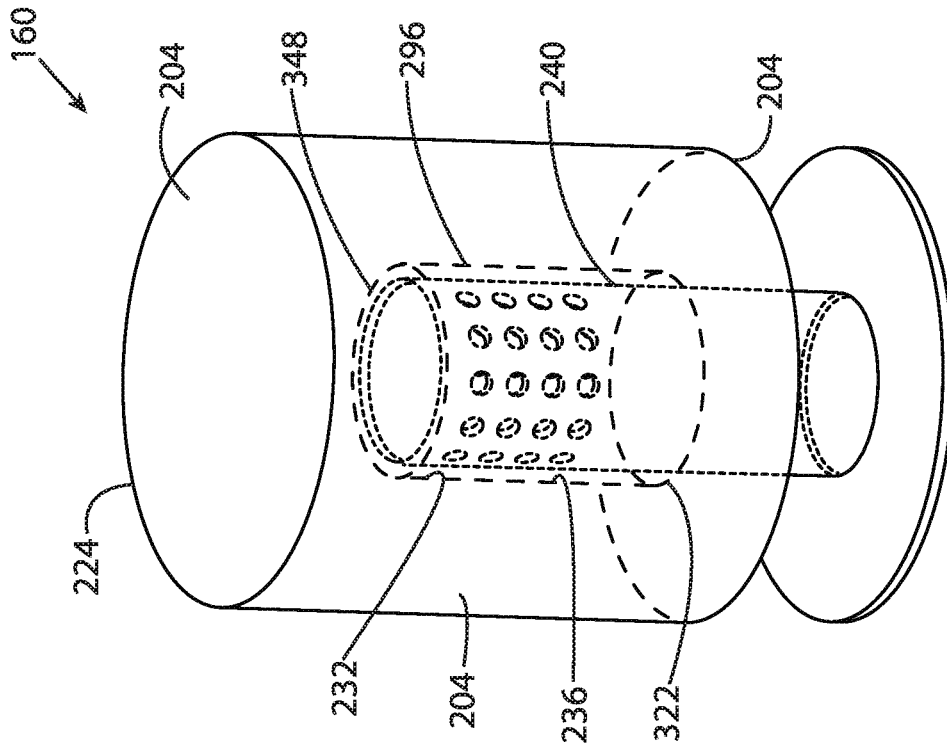

FIG. 34

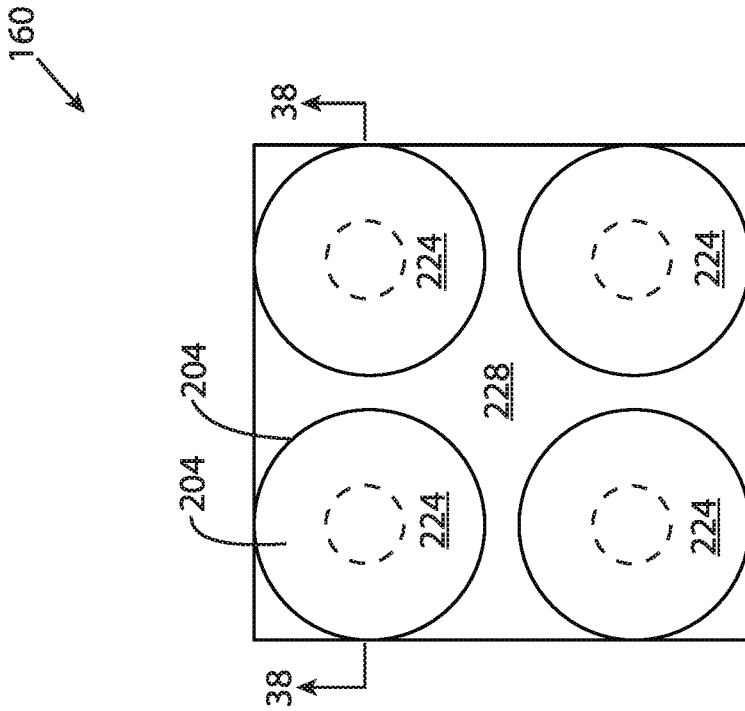

FIG. 37

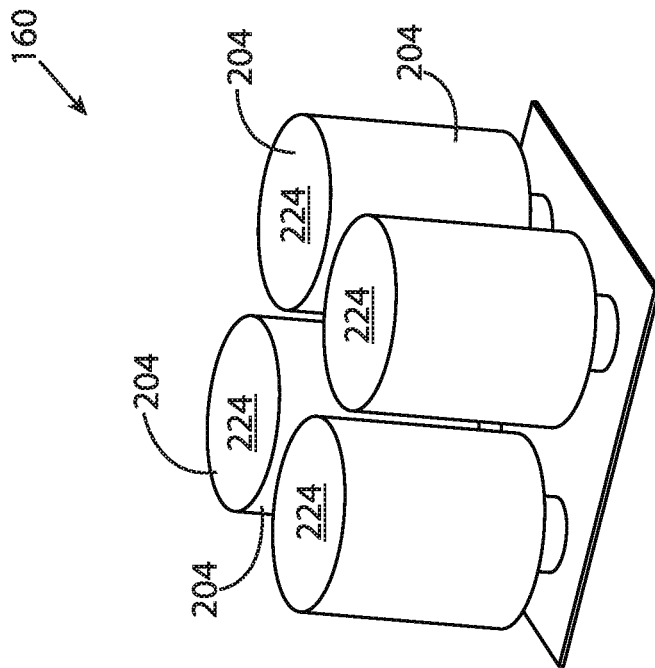

FIG. 36

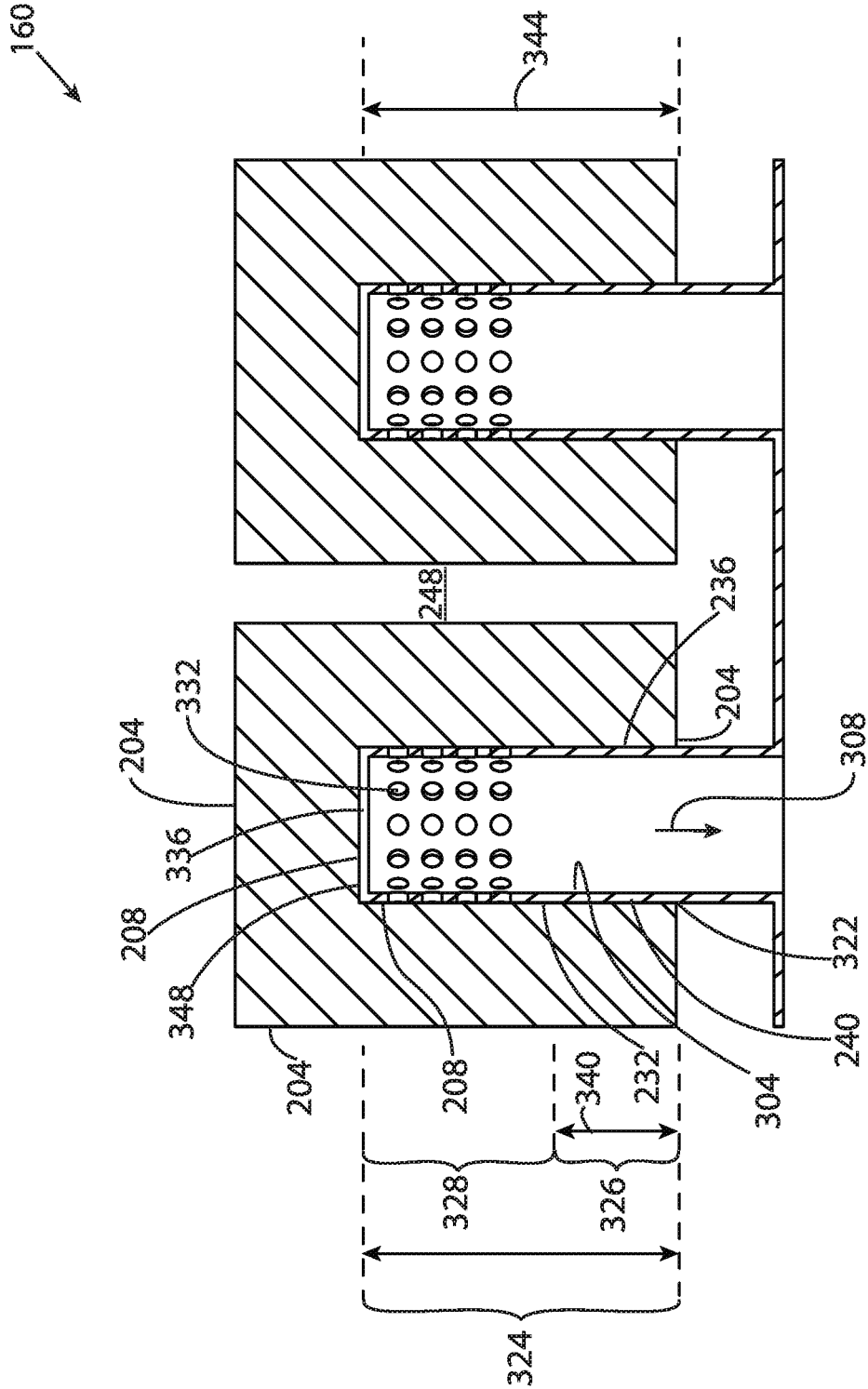

FIG. 38

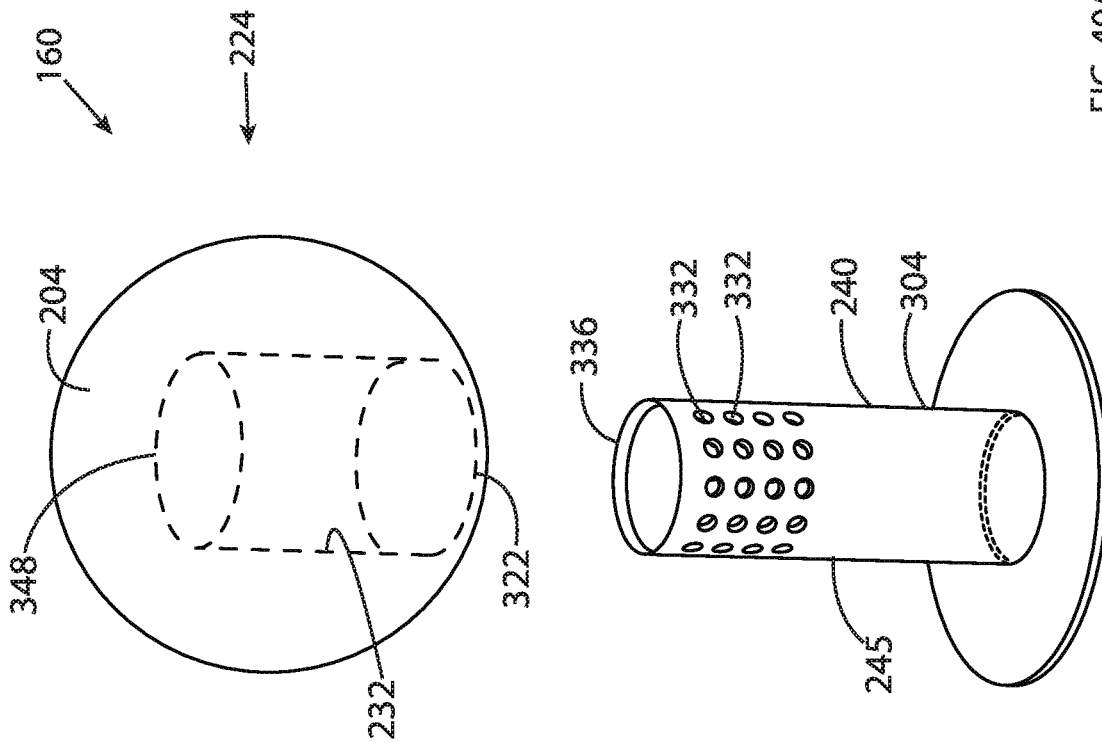

FIG. 40A

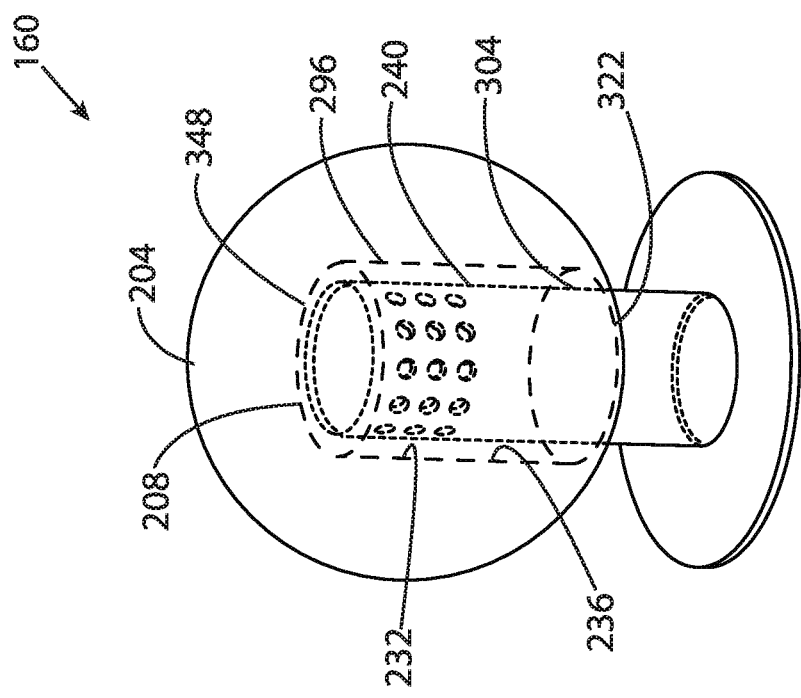

FIG. 39

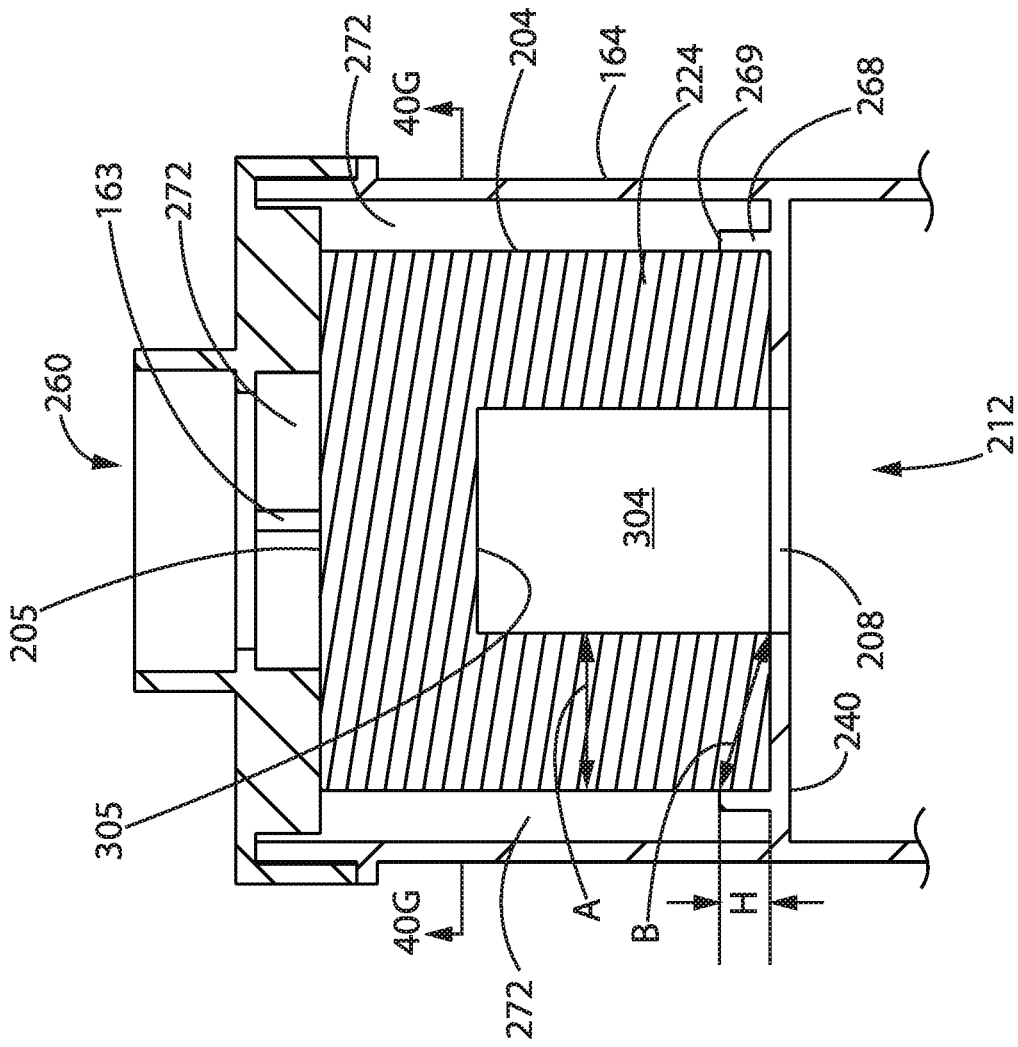

FIG. 40B

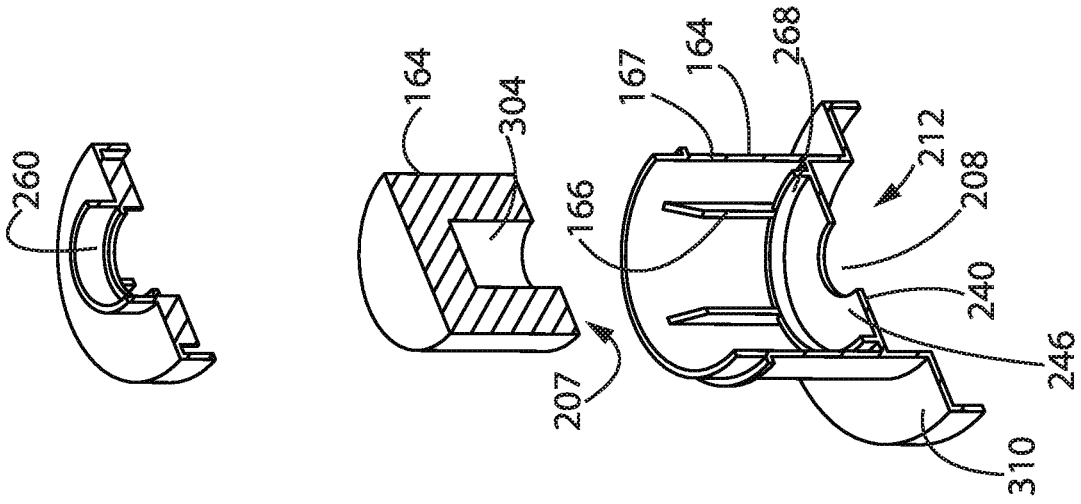

FIG. 40C

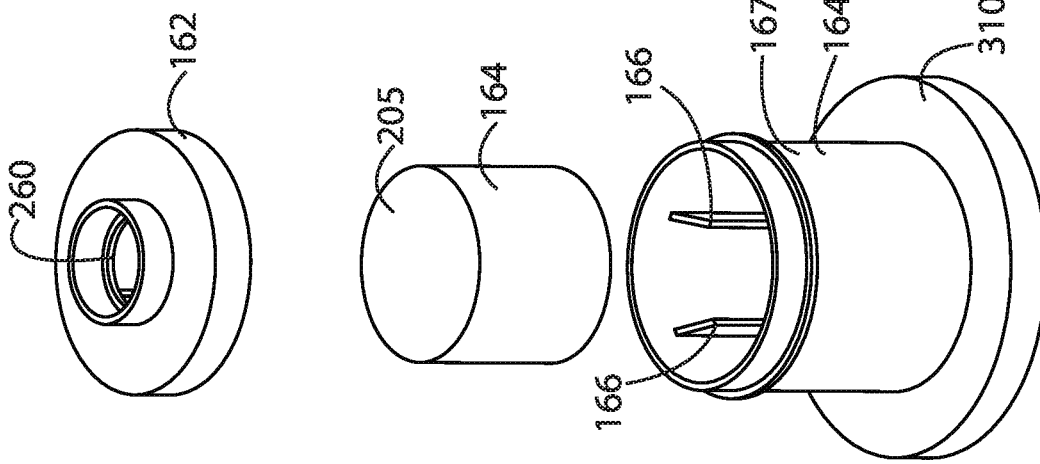

FIG. 40D

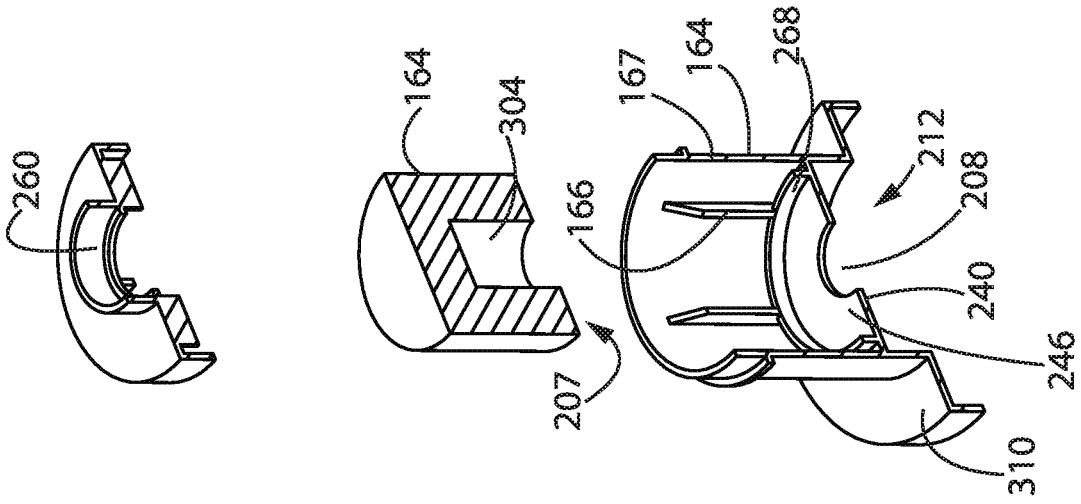
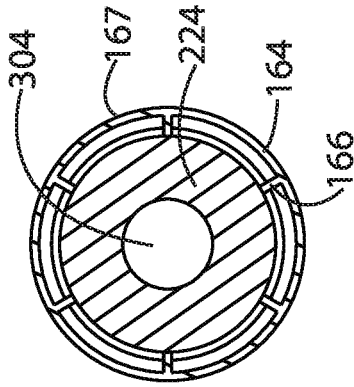
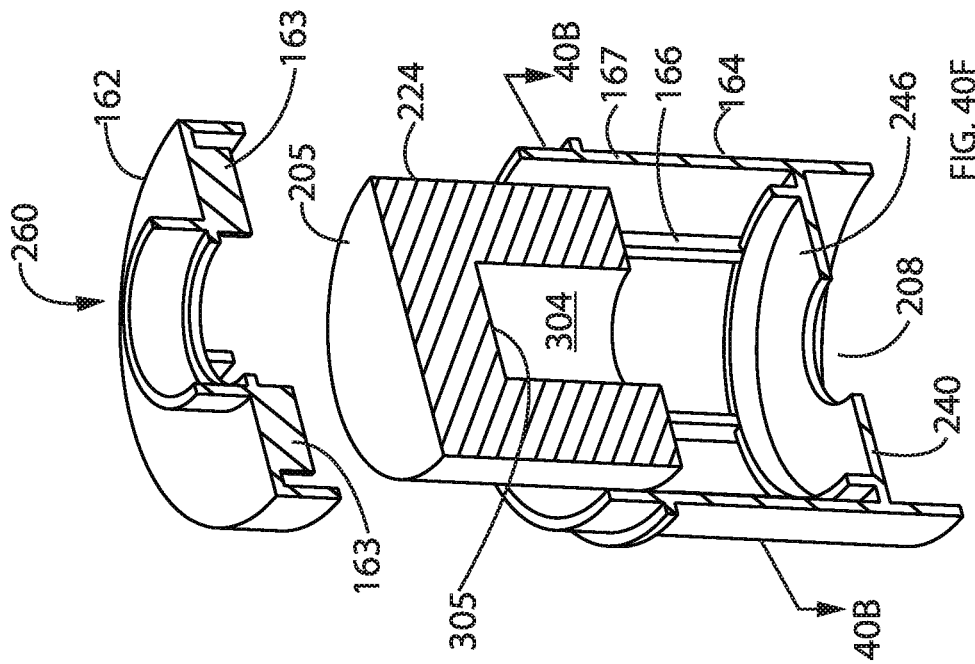

FIG. 40E



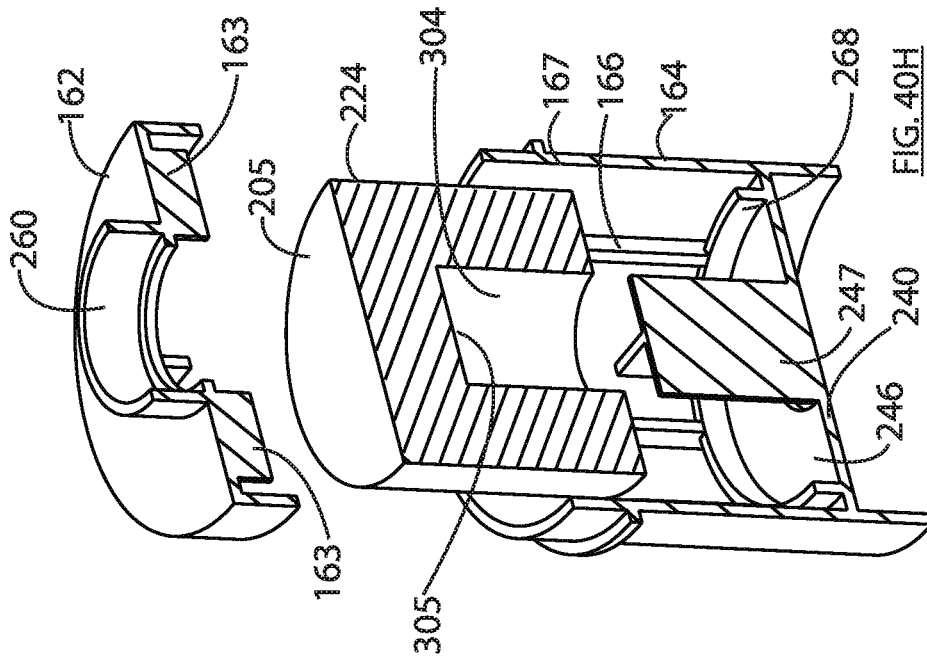

FIG. 40H

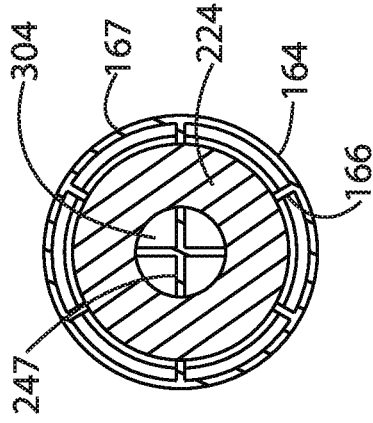

FIG. 40I

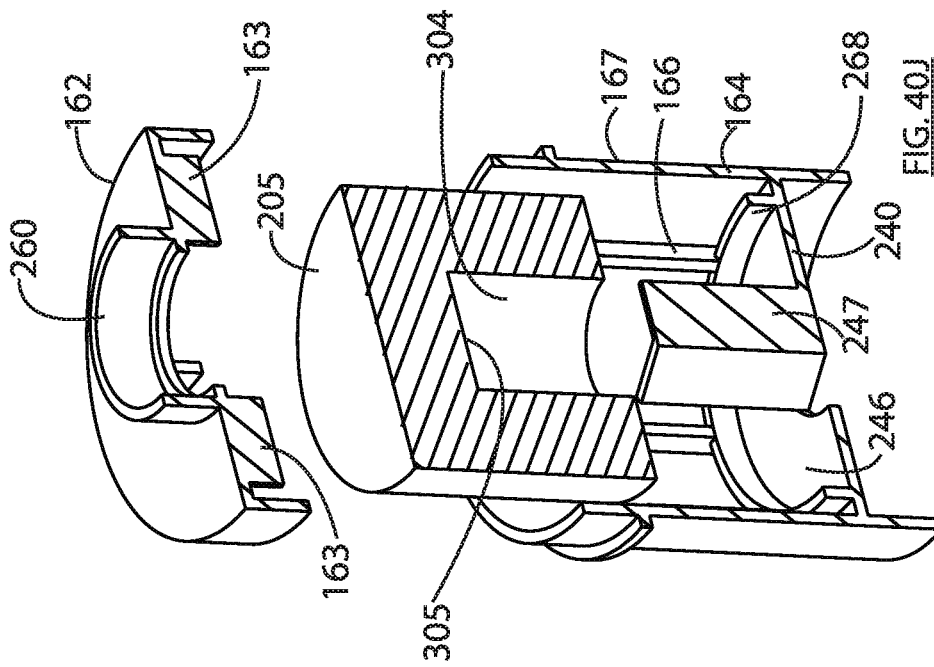

FIG. 40J

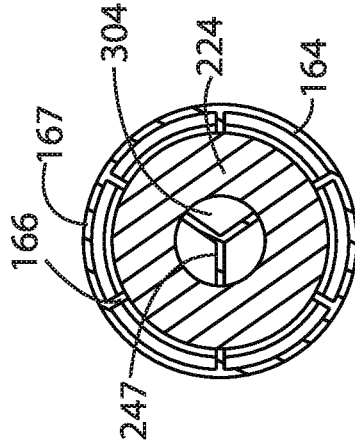

FIG. 40K

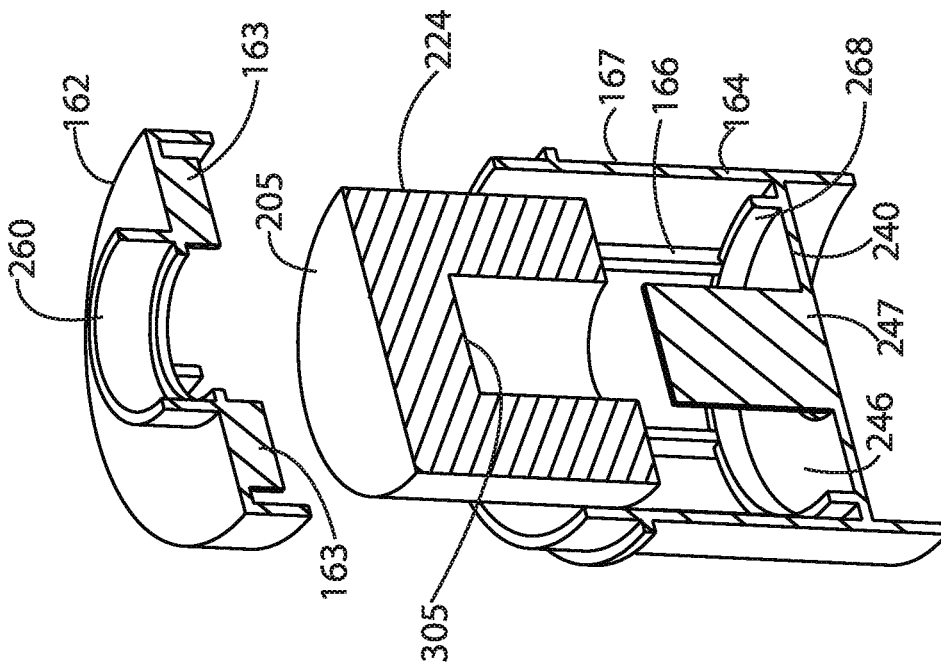

FIG. 40L

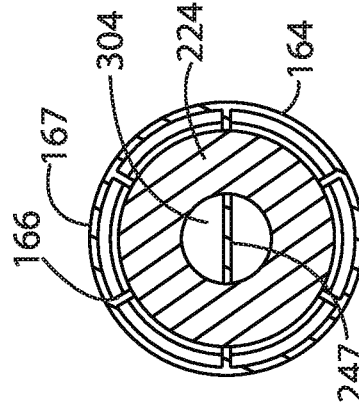

FIG. 40M

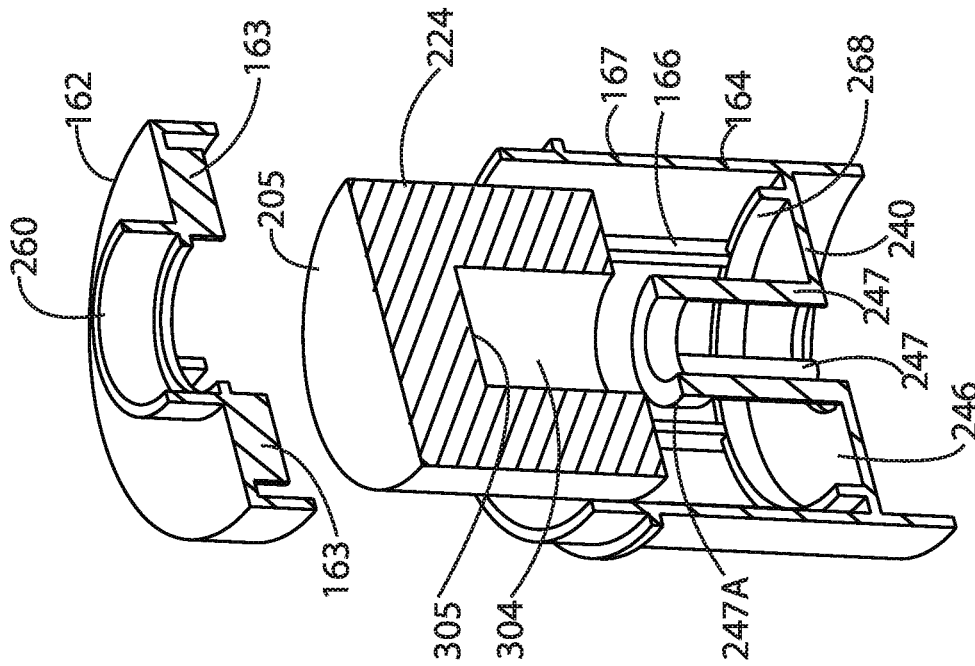

FIG. 40N

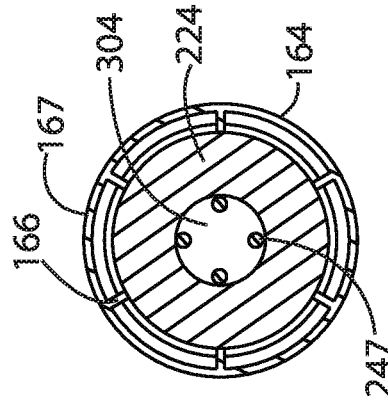

FIG. 40O

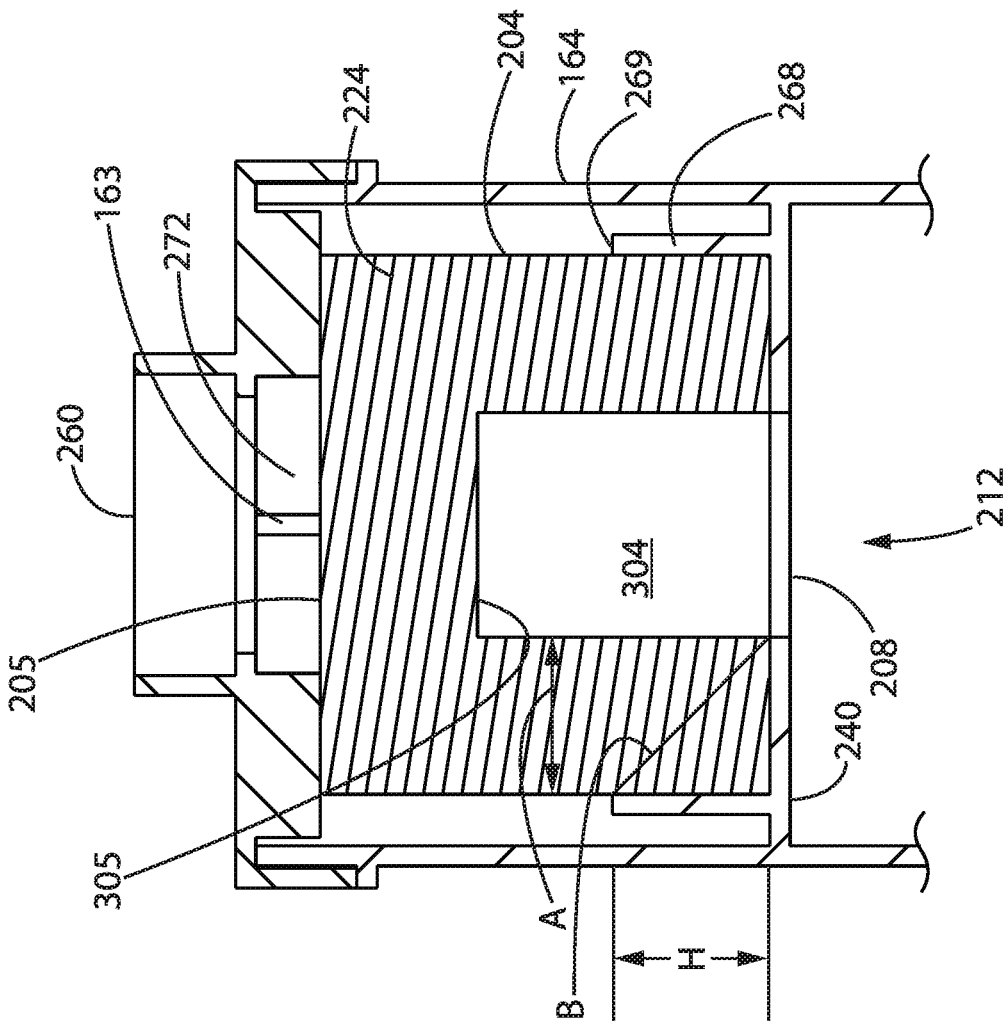

FIG. 40P

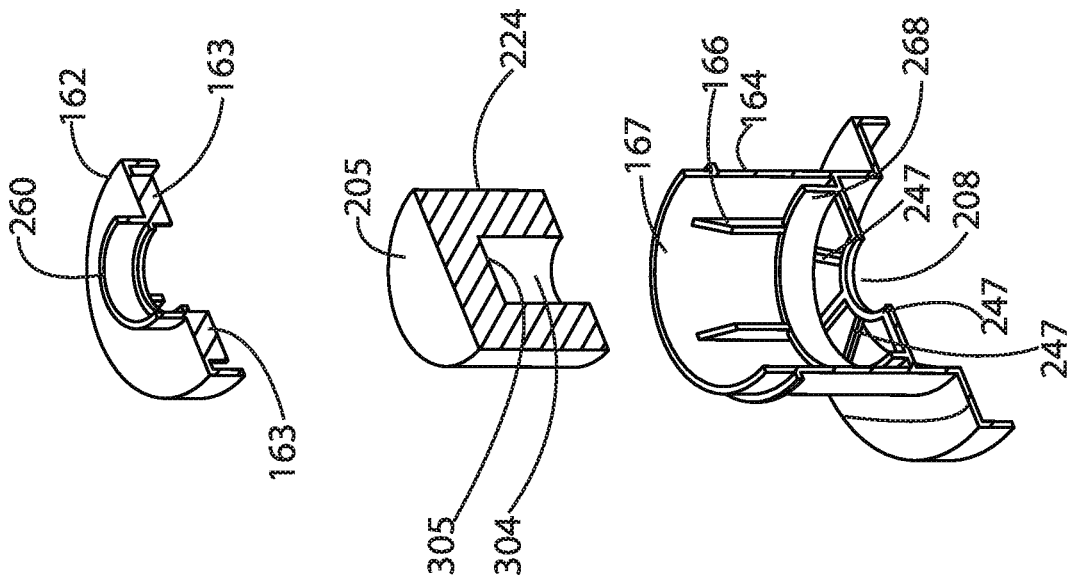
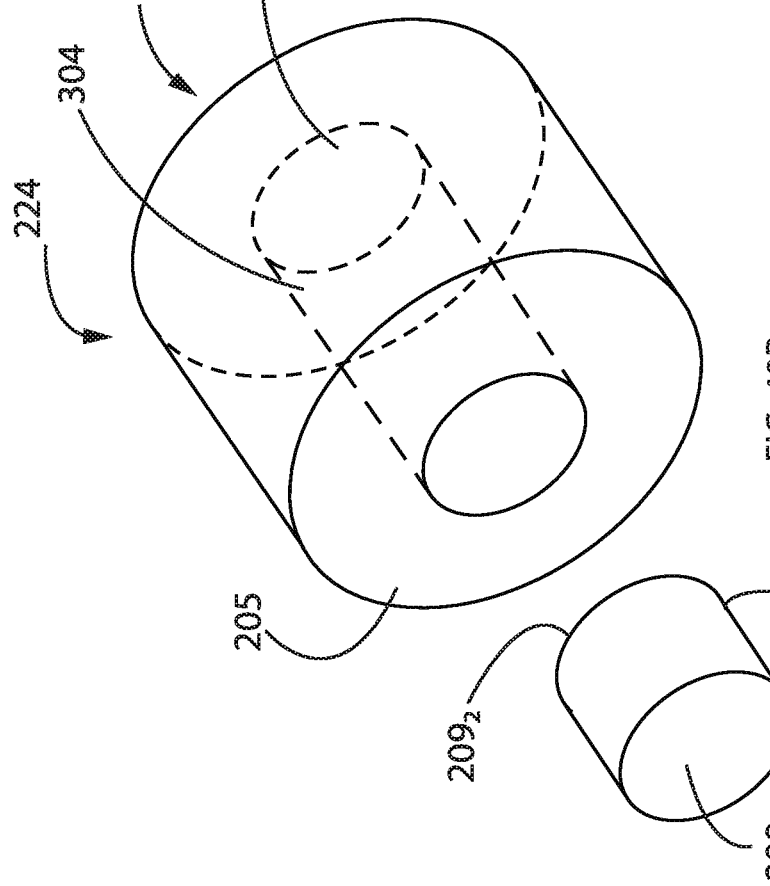
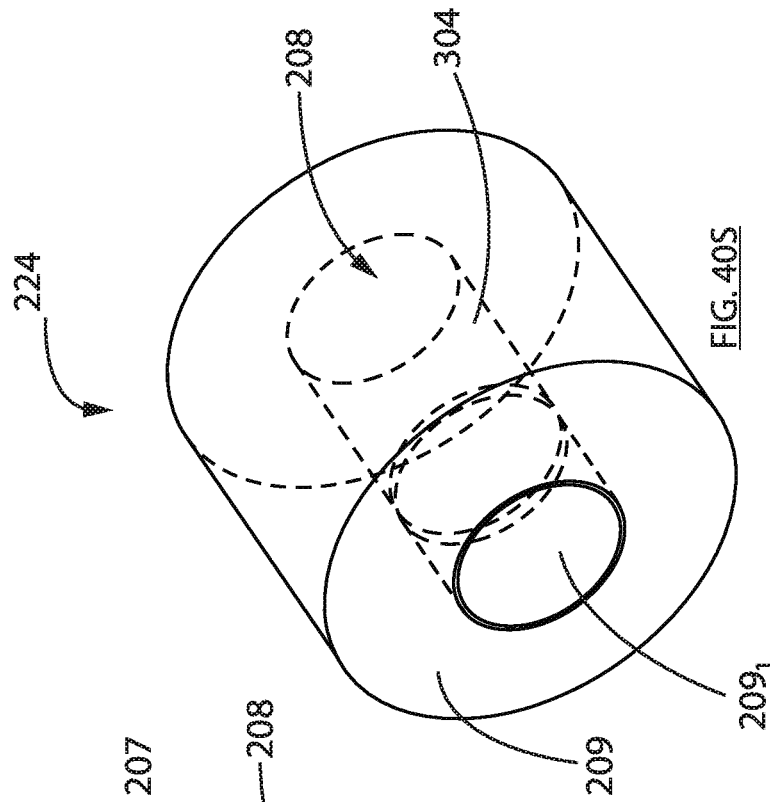
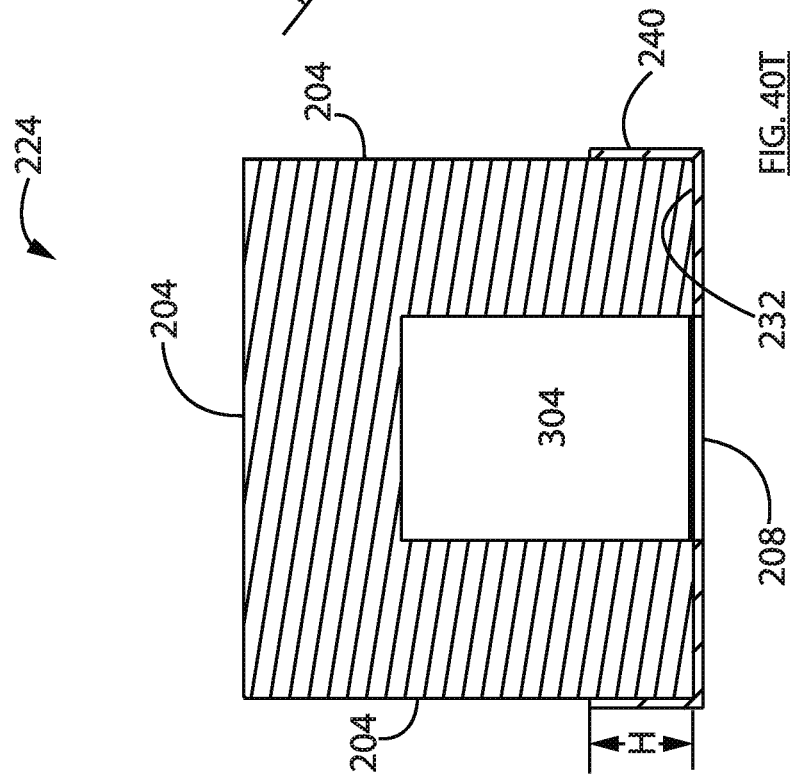
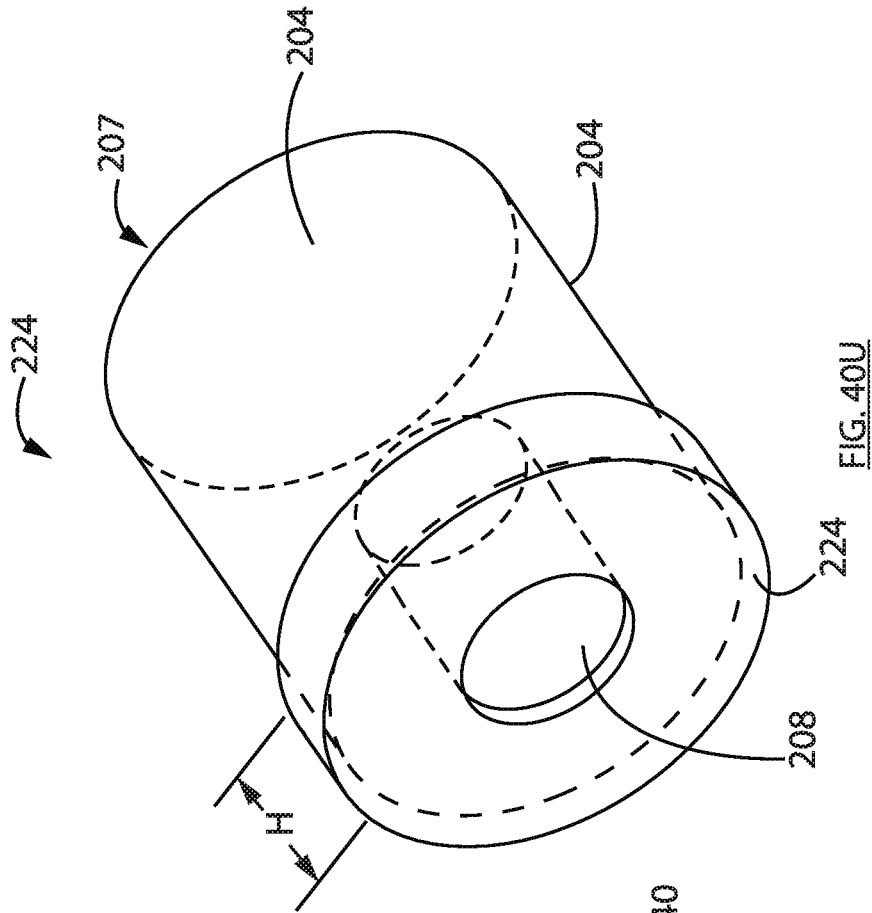

FIG. 40Q





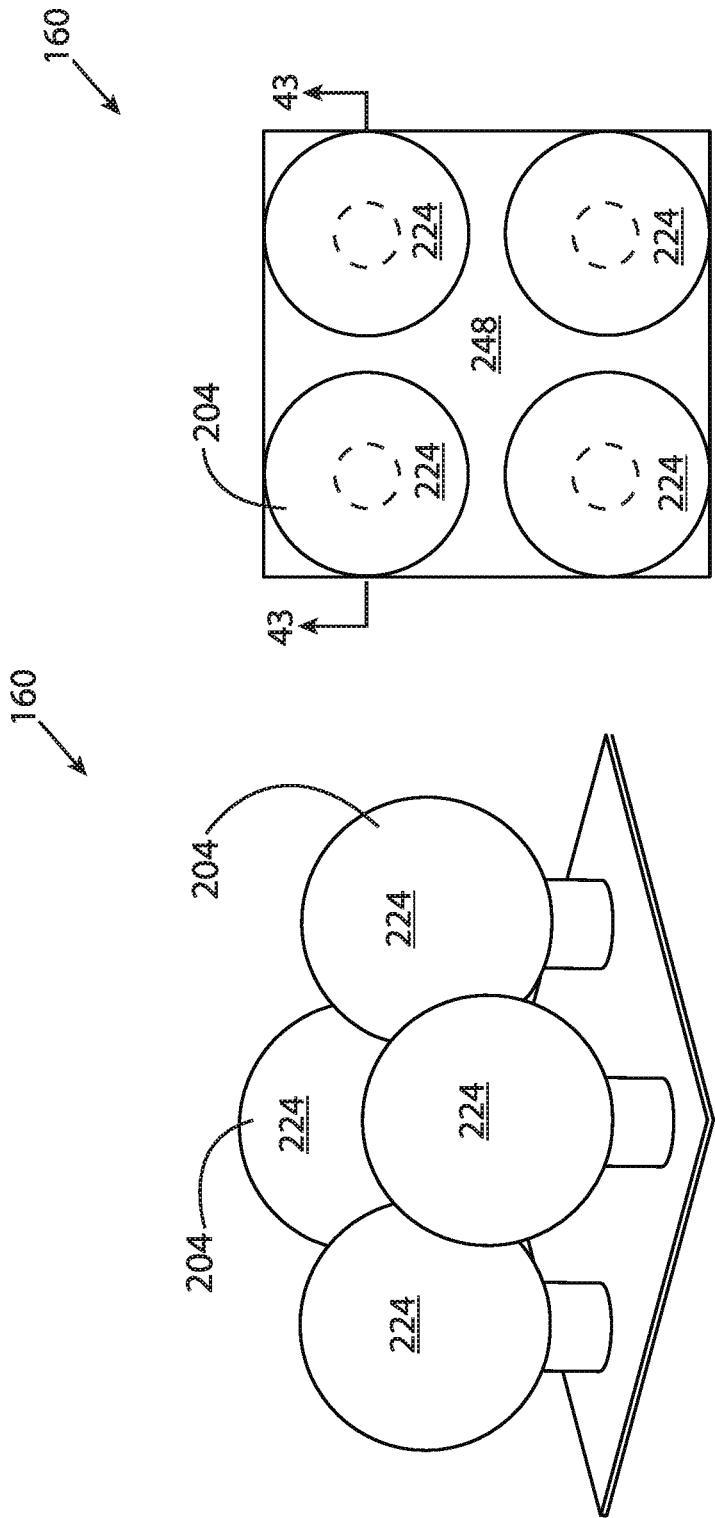

FIG. 42

FIG. 41

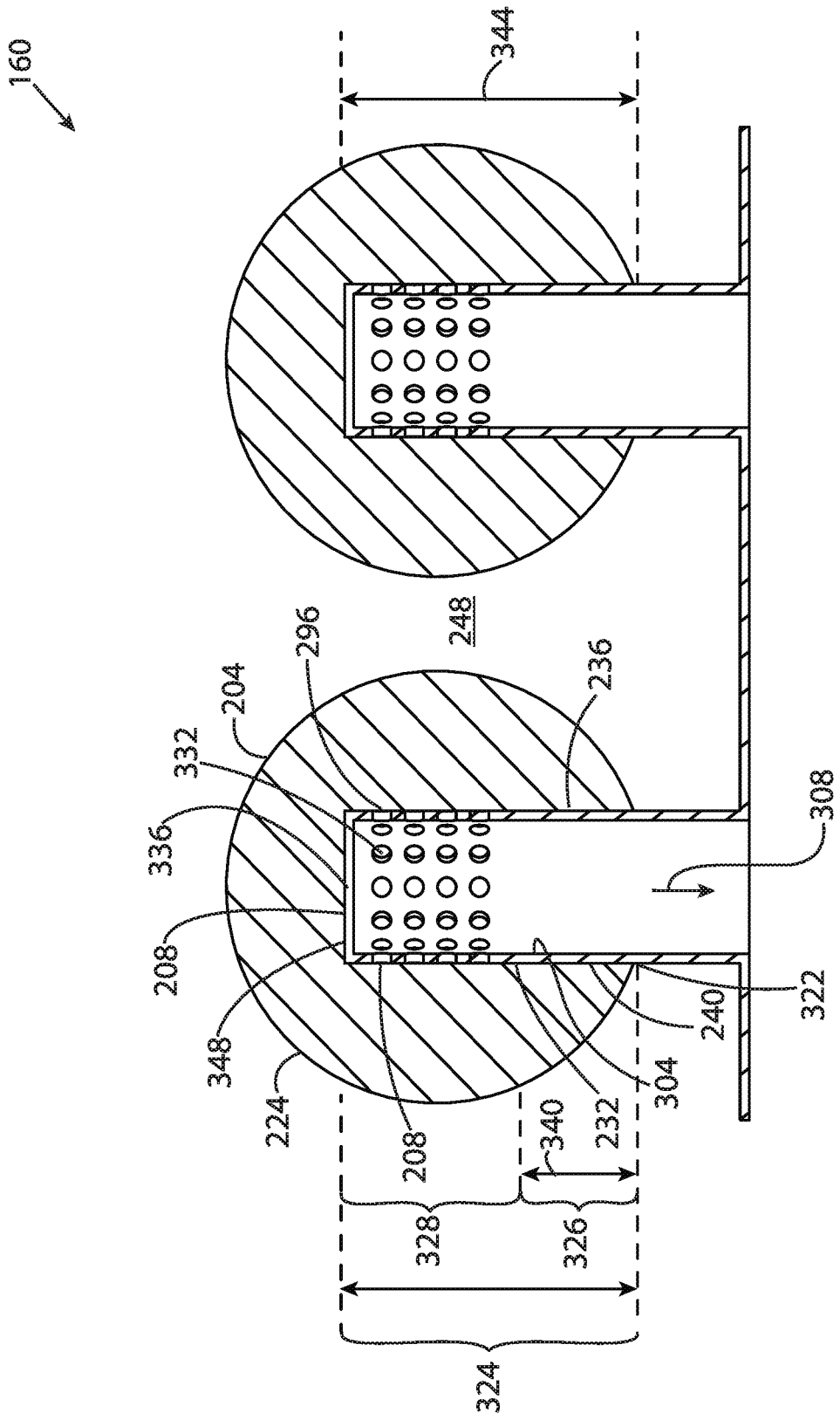

FIG. 43

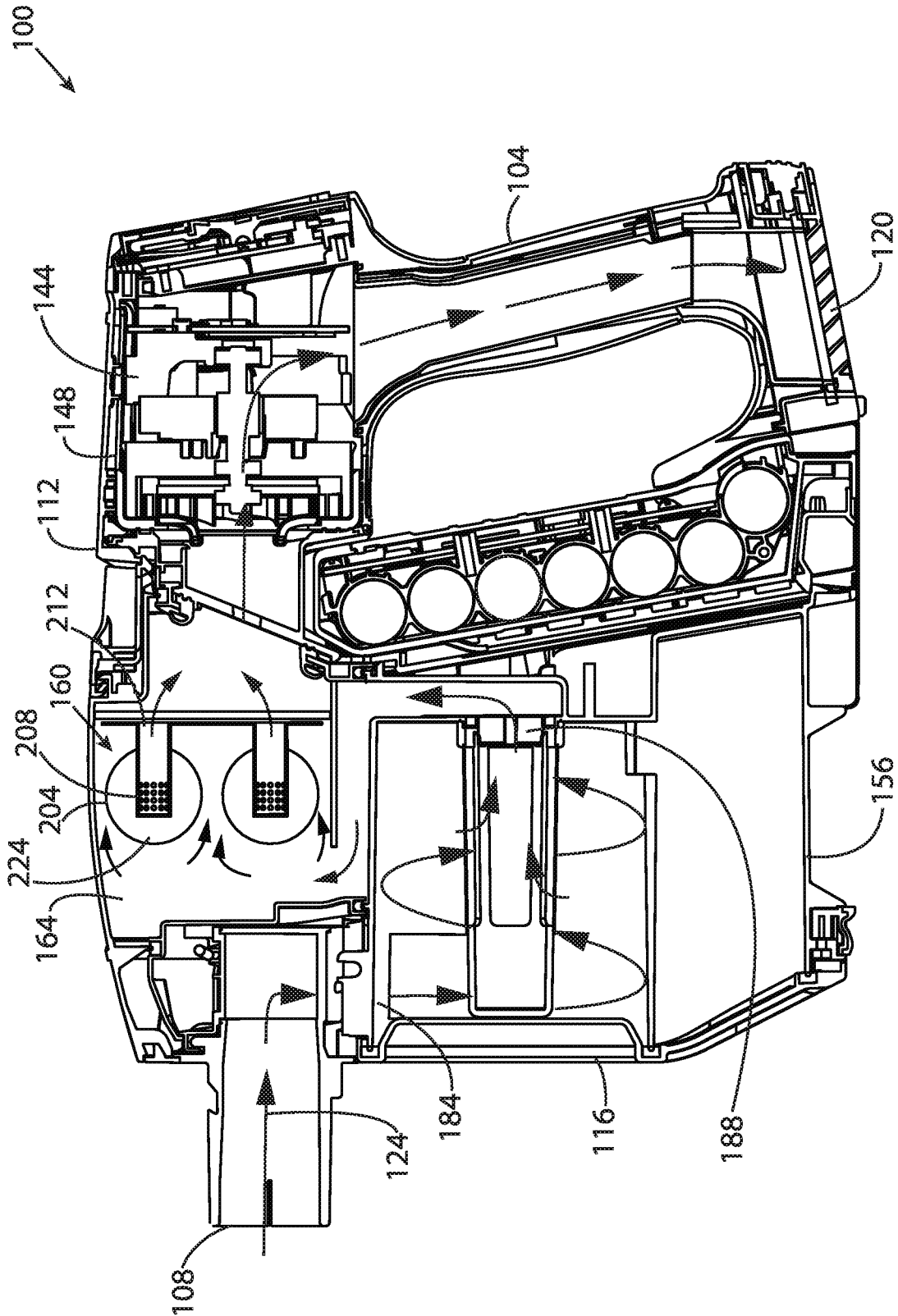

FIG. 44

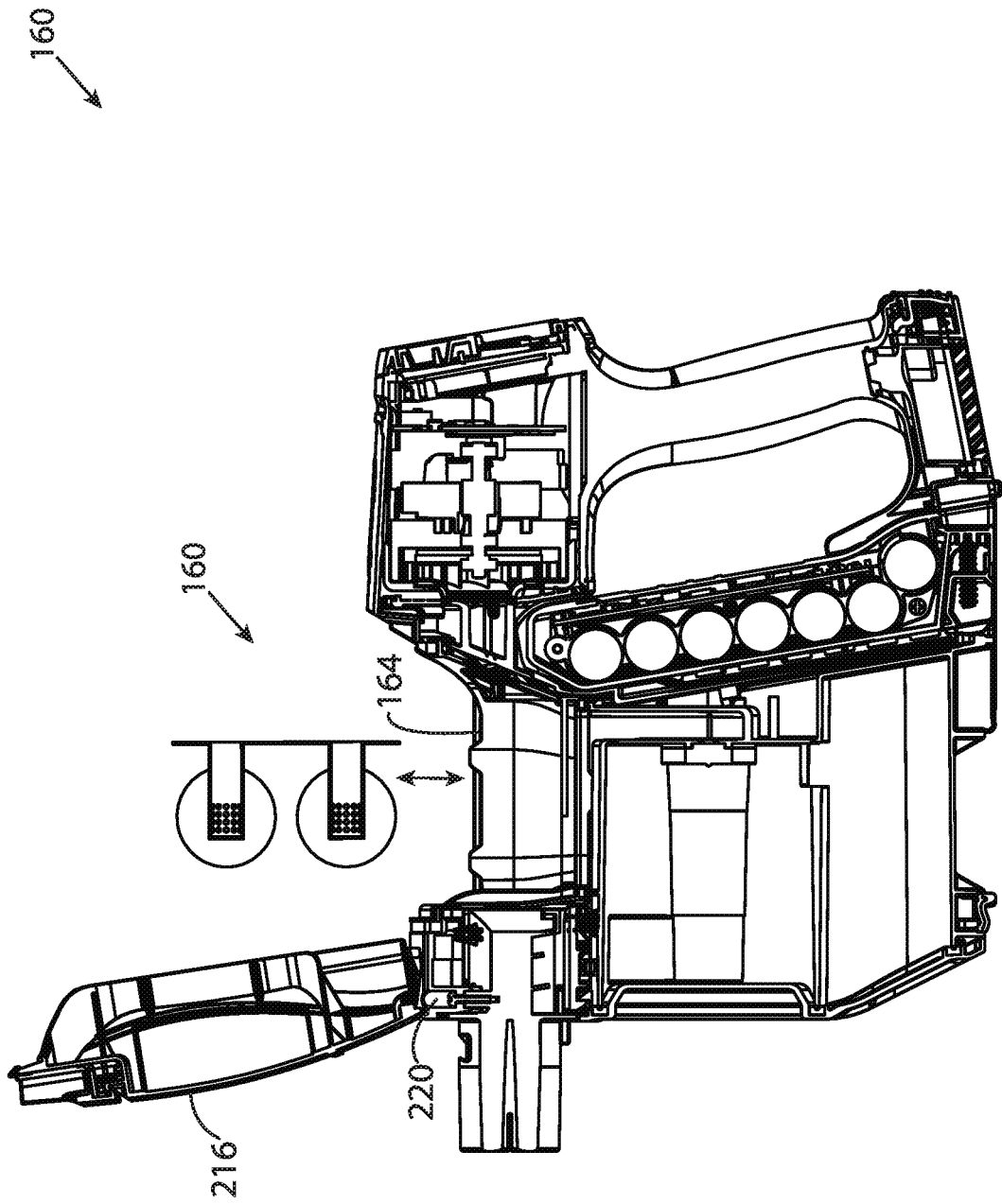

FIG. 45

1

SURFACE CLEANING APPARATUS**CROSS REFERENCE TO RELATED APPLICATIONS**

This application is a continuation in part of U.S. patent application Ser. No. 15/993,189, which was filed on May 30, 2018,

FIELD

This disclosure relates generally to surface cleaning apparatus.

INTRODUCTION

The following is not an admission that anything discussed below is part of the prior art or part of the common general knowledge of a person skilled in the art.

Various types of surface cleaning apparatus are known. Such surface cleaning apparatus include vacuum cleaners, including upright vacuum cleaners, hand carryable vacuum cleaners, canister-type vacuum cleaners, extractors and wet/dry type vacuum cleaners (e.g. Shop-Vac™). Some vacuum cleaners include a cyclonic separator (also referred to as a cyclone bin assembly) having a cyclone chamber and a dirt collection chamber. A motor is used to draw air through the surface cleaning apparatus. A filter, such as a pre-motor filter, may be provided in the air flow path through the surface cleaning apparatus.

SUMMARY

This summary is intended to introduce the reader to the more detailed description that follows and not to limit or define any claimed or as yet unclaimed invention. One or more inventions may reside in any combination or sub-combination of the elements or process steps disclosed in any part of this document including its claims and figures.

In one aspect, a surface cleaning apparatus is provided wherein a filter assembly, which may be a pre-motor filter, is provided. The filter assembly comprises a plurality of individual or discrete filter elements, which may be mounted on a common support member. The plurality of individual filter elements are spaced apart such that the side face of at least one individual filter element faces a side face of another individual filter element. The side faces are upstream faces of the filter assembly. An advantage of this design is that the upstream surface area of the filter assembly may be increased without increasing or substantially increasing the volume of the filter assembly.

In accordance with this aspect, there is provided a surface cleaning apparatus having an air flow path, a filter housing, and a filter member. The air flow path extends from a dirty air inlet to a clean air outlet, and an air treatment member and a suction motor are positioned in the air flow path. The filter housing is provided in the air flow path. The filter member is provided in the filter housing. The filter member comprises a plurality of individual filter elements arranged in parallel, each of the individual filter elements comprising porous filter material having at least one upstream face and at least one portion defining a porous filter media air outlet. The at least one upstream face has a larger surface area than the at least one portion. An outside gap is provided between at least some of the upstream faces and opposed facing walls of the filter housing and an inside gap is provided between opposed upstream faces. A cross-sectional area of the out-

2

side gaps and the inside gaps, in a plane transverse to a direction of air flow through the outside and inside gaps, is at least as large as a cross-sectional area of an air inlet to the air treatment member in a plane transverse to a direction of air flow through the air inlet to the air treatment member.

In some embodiments, the at least one portion may be provided on a single downstream face.

In some embodiments, only a portion of the single downstream face may be porous.

In some embodiments, an air impermeable material may be provided on a portion of the single downstream face.

In some embodiments, the at least one portion may be provided on the interior of the porous filter media and the porous filter media may have an air outlet passage extending in an air flow direction, the air outlet passage having a sidewall extending in the air flow direction and at least a portion of the air outlet passage being air impermeable.

In some embodiments, an air impermeable material may be provided on at least a portion of the sidewall of the air outlet passage.

In some embodiments, the air impermeable material may include a conduit inserted into the air outlet passage.

In some embodiments, an air impermeable material may be provided on a part of the porous filter media surrounding the porous filter media air outlet.

In some embodiments, at least some of the filter elements may have a plurality of upstream faces.

In some embodiments, at least some of the individual filter elements may be generally polyhedron in shape.

In some embodiments, at least some of the individual filter elements may be generally annular in transverse section and may be at least partially nested inside each other.

In accordance with this aspect, there is also provided a surface cleaning apparatus. The surface cleaning apparatus includes an air flow path and an individual filter element. The air flow path extends from a dirty air inlet to a clean air outlet. An air treatment member and a suction motor are positioned in the air flow path. The individual filter element includes a porous filter material having at a plurality of upstream faces and at least one portion defining a porous filter media air outlet. The at least one upstream face has a larger surface area than the at least one portion.

In some embodiments, the at least one portion may be provided on a single downstream face.

In some embodiments, only a portion of the single downstream face may be porous.

In some embodiments, an air impermeable material may be provided on a portion of the single downstream face.

In some embodiments, the at least one portion may be provided on the interior of the porous filter media and the porous filter media may have an air outlet passage extending in an air flow direction, the air outlet passage having a sidewall extending in the air flow direction and at least a portion of the air outlet passage being air impermeable.

In some embodiments, an air impermeable material may be provided on at least a portion of the sidewall of the air outlet passage.

In some embodiments, the air impermeable material may include a conduit inserted into the air outlet passage.

In accordance with another aspect, a filter for a surface cleaning apparatus, such as a pre-motor filter, may be subdivided into two or more sub-assemblies wherein each sub assembly comprises a plurality of individual or discrete filter elements, which may be mounted on a common support member.

In accordance with this aspect, there is provided a surface cleaning apparatus having an air flow path, a first filter part,

and a second filter part. The air flow path extends from a dirty air inlet to a clean air outlet. An air treatment member and a suction motor are positioned in the air flow path. The first filter part includes a first plurality of individual filter elements in parallel and is located at a first location in the surface cleaning apparatus. The second filter part includes a second plurality of individual filter elements in parallel and is located at a second location in the surface cleaning apparatus. Each of the individual filter elements includes porous filter material having at least one upstream face and at least one portion defining a porous filter media air outlet. The at least one upstream face has a larger surface area than the at least one portion.

In some embodiments, at least some of the individual filter elements may be generally polyhedron in shape.

In accordance with another aspect, a filter assembly is provided wherein the filter or the filter housing is provided with an air impermeable member on or abutting the upstream outer face of the porous filter media to promote air passing through a minimum path through the porous filter media.

In accordance with this aspect, there is provided a surface cleaning apparatus comprising an air flow path extending from a dirty air inlet to a clean air outlet with an air treatment member and a suction motor positioned in the air flow path. A filter housing has an axially extending filter chamber having an inlet end and an outlet end, the filter housing having an air impermeable wall extending from the outlet end towards the inlet end of the filter housing. A filter comprises a porous filter media positioned in the filter housing, the porous filter media having an outer upstream surface and an inner outlet passage defining a downstream surface and having an axial flow direction, the outlet passage terminating at an outlet port provided in an end face of the porous filter media, the outer upstream surface abutting the air impermeable wall.

In some embodiments, the porous filter media may have an absence of a support member inside the outlet passage.

In some embodiments, the air impermeable wall may have a greater axial length than a thickness of the porous filter media from the inner outlet passage to the outer upstream wall in a plane transverse to the axial flow direction.

In some embodiments, a distance from an axially inward end of the air impermeable wall to the outlet port may be greater than 110%, 125% or 150% a thickness of the porous filter media from the inner outlet passage to the outer upstream wall in a plane transverse to the axial flow direction.

In some embodiments, the surface area of the outer upstream surface of the porous filter media may be at least as great as a cross-sectional area of the filter housing air inlet in a direction transverse to a direction of flow through the filter housing air inlet.

In some embodiments, the end face maybe provided with an air impermeable material surrounding the outlet port. The air impermeable material surrounding the outlet port may be attached to the end face of the porous filter media. Alternately, or in addition, the air impermeable material surrounding the outlet port may comprise an air outlet end wall of the filter housing.

In some embodiments, a plurality of ribs may be provided at the outlet end of the filter chamber.

In some embodiments, a distance from an axially inward end of the air impermeable wall to the outlet port may be at least as great as a thickness of the porous filter media from

the inner outlet passage to the outer upstream wall in a plane transverse to the axial flow direction.

In some embodiments, the porous filter media may comprise an axially extending annular filter member having a first end, an axially spaced apart second end and an inner open volume extending axially from the first end to the opposed second end, and an separately formed insert is provided in and closes the first end of the open volume. The insert may be made of a porous filter media.

In accordance with this aspect, there is also provided a surface cleaning apparatus comprising an air flow path extending from a dirty air inlet to a clean air outlet with an air treatment member and a suction motor positioned in the air flow path. A filter housing has an axially extending filter chamber having an inlet end and an outlet end spaced from the inlet end in an axial direction, the filter housing having an air impermeable wall extending from the outlet end towards the inlet end of the filter housing. A filter comprises a porous filter media positioned in the filter housing, the porous filter media having an outer upstream surface and an outlet portion provided in an end face of the porous filter media, the outer upstream surface abutting the air impermeable wall.

In some embodiments, the air impermeable wall may have a greater axial length than a quarter of a thickness of the porous filter media in a plane transverse to the axial direction.

In some embodiments, the air impermeable wall may have a greater axial length than a third of a thickness of the porous filter media in a plane transverse to the axial direction.

In some embodiments, the surface area of the outer upstream surface of the porous filter media may be at least as great as a cross-sectional area of the filter housing air inlet in a direction transverse to a direction of flow through the filter housing air inlet.

In some embodiments, the end face may be provided with an air impermeable material surrounding the outlet portion. The air impermeable material surrounding the outlet portion may be attached to the end face of the porous filter media. Alternately or in addition, the air impermeable material surrounding the outlet portion may comprise an air outlet end wall of the filter housing.

In some embodiments, a plurality of ribs may be provided at the outlet end of the filter chamber.

In some embodiments, a distance from an axially inward end of the air impermeable wall to the outlet port may be at least as great as a thickness of the porous filter media from the inner outlet passage to the outer upstream wall in a plane transverse to the axial flow direction.

In some embodiments, the porous filter media may comprise an axially extending annular filter member having a first end, an axially spaced apart second end and an inner open volume extending axially from the first end to the opposed second end, and an separately formed insert is provided in and closes the first end of the open volume. The insert may be made of a porous filter media.

In accordance with another aspect, a filter, which is made of a porous filter media, and which has an inner outlet passage, may be formed as an annular member (e.g., by extrusion or molding) and one end of the inner outlet passage may be closed by an insert member. The insert member is inserted into an end of the inner outlet passage so as to inhibit air passing directly into the inner outlet passage. The insert member may be made of a porous filter media (e.g., foam) that is the same or different to that of the filter.

In accordance with this aspect, there is provided a porous filter media for a surface cleaning apparatus comprising an axially extending annular filter member having a first end, an axially spaced apart second end and an inner open volume extending axially from the first end to the opposed second end, and an separately formed insert is provided in and closes the first end of the open volume.

In some embodiments, the insert may be made of a porous filter media,

DRAWINGS

FIG. 1 is a perspective view of a surface cleaning apparatus in accordance with an embodiment;

FIG. 2 is a cross-sectional view taken along line 2-2 in FIG. 1;

FIG. 3 is the cross-sectional view of FIG. 2, with a filter housing opened and a filter member, which comprises a plurality of individual filter elements, removed, in accordance with an embodiment;

FIG. 4 is a top perspective view of a filtration assembly including a filter member in a filter housing;

FIG. 5A is a bottom perspective view of a filter element of the filter member of FIG. 4;

FIG. 5B is an exploded view of the filter element of FIG. 5A;

FIG. 6 is a top plan view of the filtration assembly of FIG. 4;

FIG. 7 is a cross-sectional view taken along line 7-7 in FIG. 4, in accordance with an embodiment;

FIG. 8 is a cross-sectional view of a filtration assembly in accordance with another embodiment;

FIG. 9 is a cross-sectional view of a filtration assembly in accordance with another embodiment;

FIG. 10 is a cross-sectional view of a filtration assembly in accordance with another embodiment;

FIG. 11 is an exploded view of the filtration assembly of FIG. 8;

FIG. 12 is a cross-sectional view of the filtration assembly of FIG. 8 and a plunger, with the filtration assembly inverted;

FIG. 13 is a cross-sectional perspective view of the filtration assembly and plunger of FIG. 12;

FIG. 14 is the cross-sectional perspective view of FIG. 13 showing a filter member compressed by the plunger;

FIG. 15 is a cross-sectional view of a filtration assembly having a screen, and a plunger, with the filtration assembly inverted, in accordance with another embodiment;

FIGS. 16-22 are top plan views of filtration assemblies in accordance with various embodiments;

FIG. 23 is a perspective view of a cross-section taken along line 23-23 in FIG. 22;

FIG. 24 is a cross-sectional view of a filtration assembly in accordance with another embodiment;

FIG. 25 is an exploded view of a filter element and filter support of the filtration assembly of FIG. 24;

FIG. 26 is a cross-sectional view of a surface cleaning apparatus in accordance with another embodiment;

FIG. 27 is a perspective view of a filter member and filter support in accordance with another embodiment;

FIG. 28 is an exploded view of the filter member and filter support of FIG. 27;

FIG. 29 is a perspective view of a filter member and filter support in accordance with another embodiment;

FIG. 30 is a top plan view of the filter member and filter support of FIG. 29;

FIG. 31 is a cross-sectional view taken along line 31-31 in FIG. 30;

FIG. 32 is a cross-sectional view of a surface cleaning apparatus including the filter member of FIG. 29;

FIG. 33 is a cross-sectional view of the surface cleaning apparatus of FIG. 32, with a filter housing opened and the filter member removed, in accordance with an embodiment;

FIG. 34 is a perspective view of a filter member and filter support in accordance with another embodiment;

FIG. 35 is an exploded view of the filter member and filter support of FIG. 34;

FIG. 36 is a perspective view of a filter member and filter support in accordance with another embodiment;

FIG. 37 is a top plan view of the filter member and filter support of FIG. 36;

FIG. 38 is a cross-sectional view taken along line 38-38 in FIG. 37;

FIG. 39 is a perspective view of a filter member and filter support in accordance with another embodiment;

FIG. 40A is an exploded view of the filter member and filter support of FIG. 39;

FIG. 40B is a cross-sectional view taken along line 40B-40B in FIG. 40F;

FIG. 40C is a perspective view of a filter housing in accordance with another embodiment;

FIG. 40D is an exploded view of the filter housing of FIG. 40C showing the filter member;

FIG. 40E is an exploded cross-sectional view along line 40-40 of the filter member and filter housing of FIG. 40C;

FIG. 40F is an exploded cross-sectional of an alternate embodiment of a filter member and filter housing showing an alternate filter housing;

FIG. 40G is a horizontal section of the embodiment of FIG. 40F taken along the line 40G-40G in FIG. 40B;

FIG. 40H is an exploded cross-sectional of an alternate embodiment of a filter member and filter housing;

FIG. 40I is a horizontal section of the embodiment of FIG. 40H taken along the line 40G-40G in FIG. 40B;

FIG. 40J is an exploded cross-sectional of an alternate embodiment of a filter member and filter housing;

FIG. 40K is a horizontal section of the embodiment of FIG. 40J taken along the line 40G-40G in FIG. 40B;

FIG. 40L is an exploded cross-sectional of an alternate embodiment of a filter member and filter housing;

FIG. 40M is a horizontal section of the embodiment of FIG. 40L taken along the line 40G-40G in FIG. 40B;

FIG. 40N is an exploded cross-sectional of an alternate embodiment of a filter member and filter housing;

FIG. 40O is a horizontal section of the embodiment of FIG. 40N taken along the line 40G-40G in FIG. 40B;

FIG. 40P is a cross-sectional view taken along line 40B-40B in FIG. 40F of a further alternate embodiment of a filter member and filter housing;

FIG. 40Q is an exploded view of the filter member and filter housing of FIG. 40P;

FIG. 40R is an exploded view of an alternate filter member;

FIG. 40S is an assembled view of the filter member of FIG. 40R;

FIG. 40T is a longitudinal sectional view of an alternate filter member;

FIG. 40U is a perspective view of the filter member of FIG. 40T;

FIG. 41 is a perspective view of a filter member in accordance with another embodiment;

FIG. 42 is a top plan view of the filter member of FIG. 41;

FIG. 43 is a cross-sectional view taken along line 43-43 in FIG. 42;

FIG. 44 is a cross-sectional view of a surface cleaning apparatus including the filter member of FIG. 41; and,

FIG. 45 is a cross-sectional view of the surface cleaning apparatus of FIG. 44, with a filter housing opened and the filter member removed, in accordance with an embodiment.

DESCRIPTION OF VARIOUS EMBODIMENTS

Various apparatuses, methods and compositions are described below to provide an example of an embodiment of each claimed invention. No embodiment described below limits any claimed invention and any claimed invention may cover apparatuses and methods that differ from those described below. The claimed inventions are not limited to apparatuses, methods and compositions having all of the features of any one apparatus, method or composition described below or to features common to multiple or all of the apparatuses, methods or compositions described below. It is possible that an apparatus, method or composition described below is not an embodiment of any claimed invention. Any invention disclosed in an apparatus, method or composition described below that is not claimed in this document may be the subject matter of another protective instrument, for example, a continuing patent application, and the applicant(s), inventor(s) and/or owner(s) do not intend to abandon, disclaim, or dedicate to the public any such invention by its disclosure in this document.

The terms “an embodiment,” “embodiment,” “embodiments,” “the embodiment,” “the embodiments,” “one or more embodiments,” “some embodiments,” and “one embodiment” mean “one or more (but not all) embodiments of the present invention(s),” unless expressly specified otherwise.

The terms “including,” “comprising” and variations thereof mean “including but not limited to,” unless expressly specified otherwise. A listing of items does not imply that any or all of the items are mutually exclusive, unless expressly specified otherwise. The terms “a,” “an” and “the” mean “one or more,” unless expressly specified otherwise.

As used herein and in the claims, two or more parts are said to be “coupled,” “connected,” “attached,” “joined,” “affixed,” or “fastened” where the parts are joined or operate together either directly or indirectly (i.e., through one or more intermediate parts), so long as a link occurs. As used herein and in the claims, two or more parts are said to be “directly coupled,” “directly connected,” “directly attached,” “directly joined,” “directly affixed,” or “directly fastened” where the parts are connected in physical contact with each other. As used herein, two or more parts are said to be “rigidly coupled,” “rigidly connected,” “rigidly attached,” “rigidly joined,” “rigidly affixed,” or “rigidly fastened” where the parts are coupled so as to move as one while maintaining a constant orientation relative to each other. None of the terms “coupled,” “connected,” “attached,” “joined,” “affixed,” and “fastened” distinguish the manner in which two or more parts are joined together.

Furthermore, it will be appreciated that for simplicity and clarity of illustration, where considered appropriate, reference numerals may be repeated among the figures to indicate corresponding or analogous elements. In addition, numerous specific details are set forth in order to provide a thorough understanding of the example embodiments described herein. However, it will be understood by those of ordinary skill in the art that the example embodiments described herein may be practiced without these specific details. In

other instances, well-known methods, procedures, and components have not been described in detail so as not to obscure the example embodiments described herein. Also, the description is not to be considered as limiting the scope of the example embodiments described herein.

General Description of a Vacuum Cleaner

Referring to FIGS. 1-2, an exemplary embodiment of a surface cleaning apparatus is shown generally as 100. The following is a general discussion of apparatus 100 which provides a basis for understanding several of the features that are discussed herein. As discussed subsequently, each of the features may be used individually or in any particular combination or sub-combination in this or in other embodiments disclosed herein.

Embodiments described herein include an improved filter member 160, and a surface cleaning apparatus 100 including the same. Surface cleaning apparatus 100 may be any type of surface cleaning apparatus, including for example a hand vacuum cleaner as shown, a stick vacuum cleaner, an upright vacuum cleaner, a canister vacuum cleaner, an extractor or a wet/dry type vacuum cleaner. Optionally, the surface cleaning apparatus may use one or more cyclones and may therefore be a cyclonic surface cleaning apparatus.

In FIGS. 1-2, surface cleaning apparatus 100 is illustrated as a hand vacuum cleaner, which may also be referred to also as a “handvac” or “hand-held vacuum cleaner”. As used herein, a hand vacuum cleaner is a vacuum cleaner that can be operated to clean a surface generally one-handedly. That is, the entire weight of the vacuum may be held by the same one hand used to direct a dirty air inlet of the vacuum cleaner with respect to a surface to be cleaned. For example, handle 104 and dirty air inlet 108 may be rigidly coupled to each other (directly or indirectly), such as being integrally formed or separately molded and then non-removably secured together such as by an adhesive or welding, so as to move as one while maintaining a constant orientation relative to each other. This is to be contrasted with canister and upright vacuum cleaners, whose weight is typically supported by a surface (e.g. a floor) during use, and when a canister vacuum cleaner is operated or when an upright vacuum cleaner is operated in a ‘lift-away’ configuration, a second hand is typically required to direct the dirty air inlet at the end of a flexible hose.

Still referring to FIGS. 1-2, surface cleaning apparatus 100 includes a main body or a hand vac body 112 having an air treatment member 116 (which may be permanently affixed to the main body or may be removable therefrom for emptying), a dirty air inlet 108, a clean air outlet 120, and an air flow path 124 extending between the dirty air inlet 108 and the clean air outlet 120.

Surface cleaning apparatus 100 has a front end 128, a rear end 132, an upper end (also referred to as the top) 136, and a lower end (also referred to as the bottom) 140. In the embodiment shown, dirty air inlet 108 is at an upper portion of apparatus front end 128 and clean air outlet 120 is at a rearward portion of apparatus 100 at apparatus rear end 132. It will be appreciated that dirty air inlet 108 and clean air outlet 120 may be positioned in different locations of apparatus 100.

A suction motor 144 is provided to generate vacuum suction through air flow path 124, and is positioned within a motor housing 148. Suction motor 144 may be a fan-motor assembly including an electric motor and impeller blade(s). In the illustrated embodiment, suction motor 144 is positioned in the air flow path 124 downstream of air treatment member 116. In this configuration, suction motor 144 may be referred to as a “clean air motor”. Alternatively, suction

motor **144** may be positioned upstream of air treatment member **116**, and referred to as a “dirty air motor”.

Air treatment member **116** is configured to remove particles of dirt and other debris from the air flow. In the illustrated example, air treatment member **116** includes a cyclone assembly (also referred to as a “cyclone bin assembly”) having a single cyclonic cleaning stage with a single cyclone **152** and a dirt collection chamber **156** (also referred to as a “dirt collection region”, “dirt collection bin”, “dirt bin”, or “dirt chamber”). Cyclone **152** has a cyclone chamber **154**. Dirt collection chamber **156** may be external to the cyclone chamber **154** (i.e. dirt collection chamber **156** may have a discrete volume from that of cyclone chamber **154**). Cyclone **152** and dirt collection chamber **156** may be of any configuration suitable for separating dirt from an air stream and collecting the separated dirt respectively and may be in communication by a dirt outlet of the cyclone chamber.

In alternate embodiments, air treatment member **116** may include a cyclone assembly having two or more cyclonic cleaning stages arranged in series with each other. Each cyclonic cleaning stage may include one or more cyclones arranged in parallel with each other and one or more dirt collection chambers, of any suitable configuration. The dirt collection chamber(s) may be external to the cyclone chambers of the cyclones. Alternatively, one or more (or all) of the dirt collection chamber(s) may be internal to one or more (or all) of the cyclone chambers. For example, the internal dirt collection chamber(s) may be configured as a dirt collection area within the cyclone chamber.

In other alternative embodiments, air treatment member **116** may not include a cyclonic cleaning stage. For example, air treatment member **116** may include a bag, a porous physical filter media (such as, for example foam or felt), one or more screen or other air treating means.

Referring to FIG. 2, hand vacuum cleaner **100** may include a pre-motor filter **160** provided in the air flow path **124** downstream of air treatment member **116** and upstream of suction motor **144**. Pre-motor filter **160** may be formed from any suitable physical, porous filter media (also referred to as “porous filter material”). For example, pre-motor filter **160** may be one or more of a foam filter, felt filter, HEPA filter, or other physical filter media. In some embodiments, pre-motor filter **160** may include an electrostatic filter, or the like. As shown, pre-motor filter **160** may be located in a pre-motor filter housing **164** that is external to the air treatment member **116**.

In the illustrated embodiment, dirty air inlet **108** is the inlet end **168** of an air inlet conduit **172**. Optionally, inlet end **168** of air inlet conduit **172** can be used as a nozzle to directly clean a surface. Alternatively, or in addition to functioning as a nozzle, air inlet conduit **172** may be connected (e.g. directly connected) to the downstream end of any suitable accessory tool such as a rigid air flow conduit (e.g., an above floor cleaning wand), a crevice tool, a mini brush, and the like. As shown, dirty air inlet **108** may be positioned forward of air treatment member **116**, although this need not be the case.

In the embodiment of FIG. 2, the air treatment member comprises a cyclone **152**, the air treatment air inlet is a cyclone air inlet **184**, and the air treatment member air outlet is a cyclone air outlet **188**. Accordingly, in operation, after activating suction motor **144**, dirty air enters apparatus **100** through dirty air inlet **108** and is directed along air inlet conduit **172** to the cyclone air inlet **184**. As shown, cyclone air inlet **184** may direct the dirty air flow to enter cyclone chamber **154** in a tangential direction so as to promote cyclonic action. Dirt particles and other debris may be

disentrained (i.e. separated) from the dirty air flow as the dirty air flow travels from cyclone air inlet **184** to cyclone air outlet **188**. The disentrained dirt particles and debris may discharge from cyclone chamber **154** through a dirt outlet **190** into dirt collection chamber **156** external to the cyclone chamber **154**, where the dirt particles and debris may be collected and stored until dirt collection chamber **156** is emptied.

Air exiting cyclone chamber **154** may pass through an outlet passage **192** located upstream of cyclone air outlet **188**. Cyclone chamber outlet passage **192** may also act as a vortex finder to promote cyclonic flow within cyclone chamber **154**. In some embodiments, cyclone outlet passage **192** may include a screen or shroud **196** (e.g. a fine mesh screen) in the air flow path **124** to remove large dirt particles and debris, such as hair, remaining in the exiting air flow.

From cyclone air outlet **188**, the air flow may be directed into pre-motor filter housing **164** at an upstream side **204** of pre-motor filter **160**. The air flow may pass through pre-motor filter **160** to porous filter media air outlet **208**, and then exit through pre-motor filter chamber air outlet **212** into motor housing **148**. At motor housing **148**, the clean air flow may be drawn into suction motor **144** and then discharged from apparatus **100** through clean air outlet **120**. Prior to exiting the clean air outlet **120**, the treated air may pass through a post-motor filter, which may be one or more layers of filter media.

Filter Member

Embodiments herein relate to an improved filter member. Examples illustrated in the figures show a pre-motor filter member (also referred to more simply as a ‘pre-motor filter’) positioned upstream of the suction motor. It will be appreciated that embodiments of the filter member disclosed herein may be used as a post-motor filter member (also referred to more simply as a ‘post-motor filter’) positioned downstream of the suction motor. It will also be appreciated that the filter member may be used in any filter housing and that a plurality of filter members may be used in a single apparatus.

When air flows through a filter member of porous filter media, most of the dirt particles removed from the air flow collect on upstream surfaces of the filter member (also referred to as ‘inlet surfaces’ of the filter member). An advantage of collecting dirt on exposed surfaces of the filter member is that the dirt can be more easily cleaned off of the filter member (e.g. by brushing, agitating, or washing the filter member) as compared with dirt that is trapped within the porous filter media of the filter member.

Over time, the upstream surfaces can become clogged upon collecting a threshold amount of dirt from the air flow passing through the filter media. When the upstream surfaces are clogged, the collected dirt may create substantial impedance to air flow entering the filter member through the upstream surfaces. That is, the clogged filter member may produce substantial backpressure in the air flow path. Moreover, a clogged filter member may experience greater dirt penetration into the porous filter media. Dirt that has penetrated into the inner volume of the porous filter media may be more difficult to clean. Occurrence of dirt penetration may increase because a filter member with clogged upstream surfaces has an air inlet with a much reduced effective cross-sectional area, which results in higher velocity air flow at the upstream surfaces, which drives the dirt deeper into the porous filter media. When too much dirt becomes trapped inside the porous filter media, the filter member may require replacement. Thus, dirt penetration reduces the working life of the filter member.

The disclosed filter member provides greater upstream surface area (also referred to as 'inlet surface area') as compared to prior filter designs of the same volume, all else being equal. Greater upstream surface area provides the filter member disclosed herein with more area for dirt to collect on the upstream surfaces of the filter member, and therefore the filter member can remove more dirt from an air flow before the upstream surfaces become clogged. In use, this allows the disclosed filter member to filter a greater volume of air before the filter member creates a substantial pressure drop in the air flow path or experiences substantial dirt penetration. Consequently, the disclosed filter member can be used for a longer period before cleaning or replacing the filter member. Alternately, the disclosed filter member would allow a filter having a smaller volume to be used to have the same performance as compared to prior filter designs of the same volume, all else being equal.

Referring to FIGS. 2-3, surface cleaning apparatus 100 may include a filter housing 164 that holds filter member 160. Filter member 160 is preferably removable from filter housing 164 for cleaning or replacement. Alternatively, filter member 160 may be permanently connected to filter housing 164, and user accessible for cleaning in-situ. In the example shown, filter housing 164 includes an openable door 216. When filter housing door 216 is opened, filter member 160 may be user accessible to remove filter member 160 as shown for cleaning or replacement, or to clean (e.g. agitate or brush) filter member 160 in-situ. Alternately, filter housing 164 may be removed concurrently with filter member 160.

Door 216 may be openable in any manner that provides user access to filter member 160 when opened. In the illustrated example, door 216 is rotatably (e.g. pivotably) openable by a hinge 220. Alternatively or in addition, door 216 may be openable in translation (e.g. slide along a rail), or door 216 may be removable from apparatus 100.

Alternatively or in addition to providing user access to filter member 160, filter member 160 may be cleaned automatically by apparatus 100 (e.g. by a mechanical agitator). In such embodiments, filter housing 164 may optionally provide no user access to filter member 160. For example, filter housing 164 may not include an openable door 216.

Reference is now made to FIGS. 4, 5A, and 5B. Filter member 160 can include one or a plurality of individual filter elements 224 of porous filter media. In the illustrated embodiment, filter member 160 includes a plurality of filter element 224 positioned in parallel (i.e. as opposed to in series) within the air flow path 124 (FIG. 2). Each filter element 224 has an outer surface 228 that bounds the volume of porous filter media inside. The filter element outer surface 228 includes at least one upstream face 204 (also referred to as an 'upstream surface', an 'upstream side', an 'inlet face', an 'inlet surface', or an 'inlet side') that provides an inlet for air entering the filter element 224. Filter element outer surface 228 also includes at least one portion 208 that defines an air outlet for air exiting the porous filter media. In use, air enters each filter element 224 through their respective upstream face(s) 204, travels downstream within each filter element 224, and exits each filter element 224 through their respective porous filter media air outlet(s) 208.

As shown, filter member 160 has filter elements 224, which collectively have filter element upstream faces 204 with a total surface area greater than the total surface area of the filter element portions 208 that define their porous filter media air outlets. Thus, filter member 160 has a relatively large filter element upstream surface area. As explained

above, this provides filter member 160 with a greater capacity to collect dirt on the filter element upstream faces 204, whereby the filter member 160 may operate longer between cleanings, and enjoy a longer working life before requiring replacement. Preferably, the total surface area of upstream faces 204 is at least twice the total surface area of the porous filter media air outlets 208. In the illustrated example, the total surface area of upstream faces 204 is greater than six times the total surface area of the porous filter media air outlets 208.

Referring to FIGS. 5A-5B, filter element 224 may have any number of upstream faces 204, and can have filter media outlet portion(s) 208 on any number of downstream faces 232. For example, filter element 224 may have a greater number of upstream faces 204 than downstream faces 232, which may promote a greater total inlet cross-sectional area than the total outlet cross-sectional area, depending on the size and configuration of the faces. In some embodiments, filter element 224 may be polyhedral. In the illustrated embodiment, filter element 224 is shown having a hexahedral (e.g. cubic) shape, with five upstream faces 204 and an outlet portion 208 provided on a single downstream face 232. In this example, the total surface area of upstream faces 204 is greater than five times the total surface area of the porous filter media air outlets 208.

Outlet portion 208 may include the entirety of filter element downstream face(s) 232 or a lesser portion thereof. In the illustrated embodiment, outlet portion 208 is less than the entire filter element downstream face 232, and is spaced apart from the immediately adjacent upstream faces 204. An advantage of this design is that it can require air that enters an upstream face 204 at a location nearest outlet portion 208 to travel at least a minimum distance (through the porous filter media) effective to filter dirt from the air flow. This may be referred to as preventing the airflow from 'effectively bypassing' the porous filter media. In this way, the dirt separation efficiency of the filter element 224 (i.e. the percentage of dirt removed from the filtered air) may be improved. For example, referring to FIG. 7, outlet portion may be positioned such that the minimum distance that air must travel through the filter element 224 is D. Distance D may be selected such that air travels a predetermined distance through the filter media before exiting the filter media, (in this example though outlet portion 208). It will be appreciated that if outlet portion 208 is larger (see for example FIG. 8), then distance D will be smaller unless sidewall portion 268 is longer in the axial direction (see for example FIG. 40P).

The outlet portion(s) 208 may together include any portion of filter element downstream face(s) 232. For example, outlet portion(s) 208 may have a total surface area of less than 75% of the total surface area of the filter element downstream face(s) 232. In the illustrated embodiment, outlet portion 208 is less than 50% of the surface area of the filter element downstream face 232. As shown, outlet portion 208 may be spaced apart from the upstream faces 204, which are connected to the downstream face 232. In the illustrated example, outlet portion 208 is substantially centered on upstream face 204. This may provide relatively even spacing between outlet portion 208 and the adjacent downstream faces 232. It will be appreciated that if outlet portion is larger, (e.g., it occupies a larger percentage of the downstream face 232 of the filter element 224), then if sidewall portions 268 are provided, sidewall portions 268 are preferably longer so as to increase distance D.

Still referring to FIGS. 5A-5B, downstream face 232 may include portion 208 that defines the porous filter media air

outlet, and a portion **236** that is made air impermeable by an air impermeable material **240** (also referred to as an 'air impermeable member **240**'). As shown, air impermeable material **240** may be directly and rigidly attached to downstream face **232** to inhibit air from exiting from downstream face **232** except through outlet portion **208**. In this way, air impermeable material **240** may function as an 'outlet mask' that defines (e.g. borders or circumscribes) outlet portion **208**. In the illustrated example, air impermeable material **240** surrounds outlet portion **208** in order to space outlet portion **208** from all of the upstream faces **204** that border downstream face **232**.

Air impermeable material **240** can be any discrete, air impermeable member that is applied to the porous filter media. In some embodiments, air impermeable material **240** has the form of a coating that is, for example sprayed, stamped, or rolled onto downstream face **232** of filter element **224**. In some embodiments, air impermeable material **240** may take the form of a rigid or flexible web or substrate, such as for example a paper, plastic, metal, or silicon sheet or plate, that is rigidly and directly attached to downstream face **232** of filter element **224**, such as by adhesive, a fastener, and/or fusing the air impermeable material to the filter element **224** for example. In some embodiments, air impermeable material **240** includes a combination of a coating and a web. In combination, the coating and the web may be air impermeable, even if one or both of the coating and web are air permeable individually.

As used herein, air impermeable material **240** is considered "air impermeable" where air impermeable material **240** reduces the air permeability per unit area of the surface to which it is applied by at least 75%, 80%, 85%, 90%, 95% or more than 95%.

Air impermeable material **240** may be positively connected to filter element **224** by other than, or more than, a friction fit or containment in filter housing **164** (FIG. 2). This may help ensure that the connection between air impermeable material **240** and filter element **224** is properly formed and allows air impermeable material **240** to render the portion **236** of downstream filter face **232** air impermeable.

In some embodiments, air impermeable material **240** is permanently connected to filter element **224**. That is, air impermeable material **240** cannot be removed from filter element **224** without damaging one or both of air impermeable material **240** or filter element **224**, and without having to reapply bonding agent **238** to restore the connection between air impermeable material **240** and filter element **224**. The permanent connection allows air impermeable material **240** and filter housing **164** (FIG. 4) to be user manipulated as a unitary object that can be removed and replaced as one article, for example. The permanent connection may also prevent a loss of filter performance resulting from user error in reconnecting air impermeable material **240** to filter element **224**. The permanent connection may be provided by, for example permanent adhesive, welding, coating, or melt bonding the air impermeable material **240** to filter element **224**.

FIGS. 40T-40U exemplify an embodiment wherein a coating **240**, such as an air impermeable silicon coating, is applied to the downstream face **232** and a portion of the sidewall **204** of the filter element **224**. The coating extends axially a distance H from the downstream face **232** towards the opposed upstream face **204**. An advantage of the coating is that it stiffens the downstream end of filter element **224** thereby inhibiting the collapse of outlet passage. Accordingly, in such a case a support member, such as a pipe **247** (as exemplified in FIG. 25) or an insert (as exemplified in

FIGS. 40H-40O) may not be required. Such embodiments are exemplified in FIGS. 40B-40G.

In other embodiments, air impermeable material **240** may be removably connected (e.g. semi-permanently connected) to filter element **224**. Air impermeable material **240** and filter element **224** may remain connected until a deliberate user action is taken to separate them. This may permit air impermeable material **240** to remain attached to filter element **224** throughout the lifespan of filter element **224**, and then deliberately disconnected from filter element **224** for use with a subsequent replacement filter element **224**. For example, air impermeable material **240** may be connected to filter element **224** by releasable adhesive, or a fastener (e.g. screw or nail). Reusing the air impermeable material **240** may help reduce the cost and environment impact of replacement filter elements **224**.

Filter member **160** can have filter elements **224** of any shape and positional arrangement. For example, filter member **160** can have filter elements **224** that are hexahedral (e.g. cubic) as seen in FIGS. 4 and 5A-5B, cylindrical, spherical, pyramidal, or another regular or irregular shape. All filter elements **224** may have the same shape or filter member **160** may have filter elements **224** of two or more shapes. Further, each filter element **224** may have one filter media air outlet **208**, or several spaced apart porous filter media air outlets **208**.

FIG. 16 shows an example of filter elements **224** having a rectangular cross-section with lengths **288** that are greater than their widths **292**. As shown, filter member **160** may include two, side-by-side, spaced apart filter elements **224**. Each filter element **224** is shown including three porous filter media air outlets **208** distributed along the length **288** of each filter element **224**.

FIG. 17 shows an example of filter elements **224** each having a hexagonal cross-sectional shape. As shown, hexagonal filter elements **224** are distributed in a spaced apart manner within a hexagonal filter housing **164**, and each filter element **224** is shown including one porous filter media air outlet **208**.

FIG. 18 shows an example of filter elements **224** each having an arcuate cross-sectional shape. As shown, arcuate filter elements **224** are distributed in a spaced apart manner within an arcuate filter housing **164**, and each filter element **224** is shown including one porous filter media air outlet **208**.

FIGS. 19-21 show examples of filter members **160** having filter elements **224**, each having square cross-sectional shapes that are arranged in a 3x3, 4x4, and 5x3 grid pattern respectively.

FIGS. 22-23 show an example of a filter member **160** having filter elements **2241** and **2242** that have different cross-sectional sizes and shapes. As shown, filter element **2241** has an annular shape (e.g. hollow cylindrical shape), and filter element **2242** has a circular cross-sectional shape. Also, filter element **2242** is smaller than filter element **2241**. The illustration also exemplifies that filter member **160** can have nested filter elements. In the example shown, filter element **2242** is nested within filter element **2241**. Further, the illustration exemplifies that filter member **160** can have filter elements with different numbers of porous filter media air outlets. As shown, filter element **2241** has 16 porous filter media air outlets **2081** circularly distributed in spaced apart relation, and filter element **2242** has one filter media air outlet **2082**.

Reference is now made to FIGS. 24-25. In some embodiments, outlet portion **208** need not be merely a port or opening in a porous member provided on a face of the filter

element **224**. Instead, outlet portion **208** may be an open volume formed as a recess **296** in filter element **224**. Recess **296** may provide an air outlet passage **304** which extends in an air flow direction **308**. As shown, a support member **247** may be provided inside outlet passage **304** and may be of any shape that may inhibit outlet passage **304** from collapsing as air flows through the filter element. Support member may be cylindrical, such as a pipe, all or a portion of the sidewall of which may be solid (non-porous) or, as exemplified in FIG. **40A** and upstream portion of the support member may be air permeable (e.g., it may be porous or have openings filled with e.g., a screen or mesh material or it may be formed with openings therein). As exemplified in FIGS. **40H-40I**, support member **247** may be in the form of a longitudinally extending member having an "X" shape in transverse section (i.e., it may have four, optionally equidistantly spaced, longitudinally extending ribs which extend radially outwardly from a central core). As exemplified in FIGS. **40J-40K**, support member **247** may have three, optionally equidistantly spaced, longitudinally extending ribs which extend radially outwardly from a central core. As exemplified in FIGS. **40L-40M**, support member **247** may have a singular longitudinally extending rib. As exemplified in FIGS. **40N-40O**, support member **247** may comprise a plurality, e.g., four, optionally equidistantly spaced, longitudinally extending posts, which may have at their inner end a support ring **247A**.

Air outlet passage **304** may be lined with a hollow support member (e.g., a pipe) **247**. Support member **247** has a sidewall **312**. Some or all of sidewall **312** may be air impermeable. For example, air impermeable member **240** may extend from filter element downstream face **232** into air outlet passage **304**. As illustrated, air impermeable member **240** may form a pipe or support member **247** that has a sidewall **312** that may abut the inner surface of outlet passage **304**. An advantage of this design is that the porous filter media air outlet **208** is offset from filter element downstream face **232** inwards to a position that is more evenly spaced from upstream faces **204**. This may provide each upstream face **204** with a more similar path length to porous filter media air outlet **208**, and therefore a more similar flow resistance to porous filter media air outlet **208**. In turn, this may promote a more even distribution of air flow across upstream faces **204**, which may avoid premature clogging of certain upstream faces **204** that have at least initially the lowest flow resistance to porous filter media air outlet **208** and therefore admit the most air flow.

Reference is now made to FIGS. **27-33**. In some embodiments, recess **296** defines an air outlet passage **304** extending from an upstream face **204**. As compared with the embodiment illustrated in FIGS. **24-25**, in which air outlet passage **304** extends from a downstream face **232** (some or all of which may be made air impermeable by an air impermeable member **240**), upstream face **204** may provide additional upstream surface area to filter element **224**. As discussed above, additional upstream surface area may provide the filter member **160** with more area for dirt to collect on the upstream faces **204** of the filter member **160**, and therefore the filter member **160** can remove more dirt from an air flow before the upstream faces **204** become clogged, all else being equal. In use, this allows the filter member **160** to filter a greater volume of air before the filter member **160** creates a substantial pressure drop in the air flow path or experiences substantial dirt penetration.

In the illustrated example of FIG. **27**, all exterior faces of filter element **224** may be upstream faces **204**. As shown, downstream face **232** may be defined by the interior sur-

face(s) of recess **296**. Air impermeable member **240** may extend into recess **296**, and overlie portion(s) **236** of downstream face **232** to make portion(s) **236** air impermeable. The remaining portion(s) **208** of downstream face **232** may define a porous filter media air outlet.

FIG. **27** may appear to illustrate air impermeable member **240** as being spaced apart from the interior surfaces of recess **296**. This spacing is only shown for clarity to provide air impermeable member **240** and recess **296** with distinguishable lines in the illustration. It will be understood that air impermeable member **240** is optionally in fact positioned as having flush contact with the interior surfaces of recess **296** as exemplified in FIG. **31**.

As shown, air impermeable portion **236** may extend from an upstream face **204** inwardly. That is, portion(s) **208** that defines the porous filter media air outlet may be spaced apart from recess opening **322** at the upstream face **204**. As discussed above, this may position porous filter media air outlet **208** more centrally within filter element **224**, whereby each upstream face **204** may have a more similar path length to porous filter media air outlet **208**, and therefore a more similar flow resistance to porous filter media air outlet **208**, all else being equal.

As exemplified in FIG. **31**, air impermeable member **240** includes a portion **324** within recess **296**, and recess portion **324** includes an outer portion **326** extending inwardly from upstream face **204** and an inner portion **328** extending inwardly from outer portion **326**. As shown, inner portion **328** may border (e.g. surround or circumscribe) the portion(s) **208** defining the porous filter media air outlet. Portions **208** may be bordered by openings **332** formed in inner portion **328**, an open inner end **336** of inner portion **328**, or both as shown. Outer portion **326** may not border any air outlet portion(s) **208**. For example, outer portion **326** may provide contiguous coverage (free of openings) over a length **340** of recess **296** extending from recess opening **322**. In some embodiments, and as shown, outer portion length **340** (measured in airflow direction **308**) may be at least $\frac{1}{4}$ of recess length **344** (measured in airflow direction **308**). Depending on the shape of filter element **224**, such length **340** may permit outer portion **326** to effectively offset porous filter media air outlet **208** inwardly from recess opening **322** at upstream face **204**. As discussed above, such an offset may provide numerous advantages.

The illustrated example shows air impermeable recess portion **324** formed as a pipe, which extends to an inner end **348** of filter element recess **296**. An advantage of this design is that it simplifies installing filter element **224** onto air impermeable member **240** (i.e. filter element **224** is inserted as far as possible into recess **296**). In alternative embodiments, air impermeable recess portion **324** may be spaced apart from recess inner end **348**. For example, outer portion may be secured in position, such as by an adhesive, so that no inner portion **328** is required (e.g., in FIG. **31**, inner portion may be removed and outer portion may be secured in the position shown). In such a case, outlet portion **208** comprises a contiguous (e.g. cylindrical) section of recess **296** extending from recess inner end **348**. An advantage of this design is that it may permit porous filter media air outlet **208** to have a greater surface area.

FIGS. **34-38** illustrate examples in which filter element **224** is cylindrically shaped.

FIGS. **39-45** illustrate examples in which filter element **224** has a round shape (e.g. substantially ovoid or spherical shape).

If filter element **304** has an outlet passage **304**, then as exemplified in FIGS. **40R** and **40S**, filter element **304** may

be formed (e.g., extruded) with an outlet passage **304** that extends from end face **205** to the outlet end face **207**. The upper portion of the outlet passage **304** may be filled by an insert member **209**, which has axially opposed end faces **2091** and **2092**. Insert **209** may be porous and may be made from the same material as element **224**, e.g., a porous foam. The insert **209** may be secured in position by, e.g., an adhesive or a compression fit. When secured in position, end face **205** and end face **2091** may extend in a common plane. Filter Housing Having a Filter Member

Embodiments herein relate to an improved filter housing, which may hold the filter member disclosed herein.

Reference is now made to FIGS. 2, 6, and 7. Filter member **160** may be configured (e.g. sized, shaped, and arranged) within filter housing **164** to mitigate backpressure. This allows apparatus **100** to draw greater air flow with same size of suction motor **144**, or to draw the same air flow with a smaller, lighter, less expensive suction motor **144**, all else being equal. In some embodiments, filter member **160** may be configured to provide an air flow path within filter housing **164** having a cross-sectional area that is equal to or greater than a cross-sectional area of the air flow path **124** at one or many critical positions upstream of filter housing **164**.

As shown, within filter housing **164**, a filter element **224** may be positioned with their upstream faces **204** spaced apart from opposing filter housing walls **242** by an outside gap **244**. Outside gap **244** may provide an unobstructed path for air to access and enter upstream faces **204**, which are opposed to housing walls **242**. In embodiments of filter member **160** that have more than one filter element **224**, the filter upstream faces **204** may be spaced apart from opposing upstream faces **204** of adjacent filter elements **224** by an inside gap **248**. Inside gap **248** may provide an unobstructed path for air to access and enter upstream faces **204**, which are opposed to another upstream face **204**.

Outside gaps **244** and inside gaps **248** together have a gap cross-sectional area in a plane **250** transverse to a direction of air flow through the gaps **244** and **248**. The gap cross-sectional area may be equal to or greater than the cross-sectional area of the air treatment member air inlet **184** (in a plane transverse to the direction of air flow through inlet **184**) and/or equal to or greater than the cross-sectional area of the air treatment member air outlet **188** (in a plane transverse to the direction of air flow through air outlet **188**), or both. This may mitigate backpressure that might result from a flow restriction created by the sizing of gaps **244** and **248**. As discussed above, this may permit apparatus **100** to draw greater air flow with the same size of suction motor **144**, or to draw the same air flow with a smaller, lighter, less expensive suction motor **144** that consumes less power, all else being equal. Without being limited by theory, creating backpressure expends energy, and therefore reducing backpressure may conserve energy. By conserving energy, a battery operated hand vacuum **100** may run for a longer duration on the same size of battery **252**, or run for the same duration on a smaller, lighter, and less expensive battery **252**, all else being equal.

Reference is now made to FIG. 8, which shows a filter housing **164** holding a filter member **160**, in accordance with an embodiment. Filter housing **164** may be permanently connected to or integrally formed with apparatus **100** (FIG. 1). Alternatively, filter housing **164** may be removable positionable in a corresponding cavity of apparatus **100** (FIG. 1) in the manner of a cartridge. As shown, filter housing **164** may include housing sidewalls **242** that connect an upstream wall **254** to a downstream wall **256**. Upstream wall **254** may include a filter housing air inlet **260**. Down-

stream wall **256** may include a filter housing air outlet **212**. In use, air travels from filter housing air inlet **260** through filter element upstream faces **204**, to porous filter media air outlet **208**, and then exits filter housing **164** through filter housing air outlet **212**. It will be appreciated that housing air inlet **260** and air outlet **212** do not need to be provided in opposing upstream and downstream walls **254** and **256**, so long as they are situated in the air flow path upstream and downstream of filter member **160** respectively. For example, filter housing **164** may be configured so that one or both of housing air inlet **260** and air outlet **212** are provided in a housing sidewall **242**.

Optionally, the cross-sectional area of housing air inlet **260** in a direction transverse to the direction of air flow therethrough is equal to or substantially equal to the cross-sectional area of housing air outlet **212** in a direction transverse to the direction of air flow therethrough and/or equal to or substantially equal to the cross-sectional area of outside gap **244** and inside gap **248** in a direction transverse to the direction of air flow therethrough and/or equal to or substantially equal to the cross-sectional area of outlet passage in a direction transverse to the air flow direction **308**. In other embodiments, the cross-sectional area of outside gap **244** and inside gap **248** in a direction transverse to the direction of air flow therethrough may be 100%, 200%, 300%, 400%, 500% or more of the cross-sectional area of housing air inlet **260** in a direction transverse to the direction of air flow therethrough and/or the cross-sectional area of housing air outlet **212** in a direction transverse to the direction of air flow therethrough. An advantage of this design is that, as the filter elements accumulate dirt filtered from the air stream, an increase in back pressure produced by the air flow through the filter housing will tend to be limited and may not occur.

Turning to FIG. 9, in some embodiments a filter element **224** may include an air impermeable material **240** that extends over a portion **264** of one or more upstream faces **204** that border downstream face **232**. In the illustrated example, air impermeable material **240** includes side portions **268** that extend away from downstream face **232** over a portion **264** of every upstream face **204** that borders downstream face **232**. As shown, side portions **268** sit flush against upstream face portions **264** whereby upstream face portions **264** are rendered air impermeable. This may help further mitigate air from effectively bypassing the porous filter media, by inhibiting air from entering upstream face **204** at locations which most closely border porous filter media air outlet **208**. As noted above, mitigating bypass may improve the dirt separation efficiency of filter element **224** by forcing the air flow to travel at least a minimum distance through the porous filter media.

As exemplified in FIGS. 40B-40E, filter element **224** has an internal outlet passage **304**. The filter material has a thickness **A** in a direction transverse to the longitudinal axis of outlet passage **304**. Thickness **A** may be the minimum distance that air must travel as it passes through the filter media from upstream face **204** to outlet passage **304**. For example, upper end face **305** may be spaced more than thickness **A** from the upper end face **205** of the filter element. Alternately, upper end face **305** may be spaced thickness **A** from upper end face **205**. Sidewall portion **268** may terminate at an upper end **269** such that the minimum distance **B** from outlet portion **208** to upper end **269** is greater than thickness **A**. The longitudinal extend or height **H** of sidewall portions may be 0.25-1.5 **A**, 0.25-1 **A** or 0.25-0.5 **A**. In other

embodiments, height H may be 1.5 A or more. For example, FIG. 40P show an embodiment wherein H is larger, thereby increasing distance B.

As exemplified in FIG. 40E, the air impermeable material 240 is not attached to the filter element 224 but is an end wall 246 of the outlet end of the chamber defined by filter housing 164. As such, outlet portion may be considered to be a port or opening in the end wall 246. If the end wall 246 is solid, then the height of sidewall portions 268 may be reduced to provide the minimum distance B. It will be appreciated that the end wall 246 of the chamber defined by filter housing 164 need not be solid as exemplified in FIG. 40E, but may be a plurality of ribs 247 as exemplified in FIG. 40Q. Accordingly, the space between ribs 247 may define the outlet of the filter media 224. As exemplified, ribs 247 are spaced apart equidistantly around the end of the filter chamber. It will be appreciated that ribs 247 may be spaced apart by different amounts; they need not extend continuously along the radial length of the end of the filter chamber but may be a plurality of discrete members extending inwardly from end of the filter chamber to assist in holding filter element 224 in position.

Still referring to FIG. 9, filter member 160 may be positioned within filter housing 164 with filter element(s) 224 positioned spaced apart from filter housing upstream wall 254. This may define an upstream header 272 that allows air to freely diffuse across the filter element upstream faces 204.

Alternatively or in addition, filter member 160 may be positioned within filter housing 164 with filter element(s) 224 spaced apart from filter housing downstream wall 256 to define a downstream header 276. Downstream header 276 may permit air exiting filter element(s) 224 to consolidate (i.e. rejoin, merge) and exit as a singular air flow. Filter element(s) 224 may be supported in spaced apart relation from filter housing downstream wall 256 in any manner. In the illustrated example, filter housing 164 includes sidewall supports 280 that hold filter elements 224 spaced apart from filter housing downstream wall 256. As shown, filter elements 224 may rest upon supports, such as sidewall supports 280 and/or end wall supports 282, with air impermeable material 240 in contact with the sidewall supports 280 and/or end wall supports 282. Sidewall supports 282 and/or end wall supports 282 may be integrally formed or permanently connected to air impermeable material 240 as shown, or a wall of the filter housing, such as a sidewall of the filter housing or filter housing downstream wall 256, or neither.

FIG. 9 exemplifies an embodiment wherein sidewall supports extend inwardly from a sidewall of the filter housing 164. Spacers 280 may be integrally formed or permanently connected to air impermeable material 240 as shown, or a filter housing sidewall, or neither.

FIG. 10 exemplifies an embodiment in which spacers 282 hold filter elements 224 spaced apart from filter housing downstream wall 256. As shown, spacers 282 may extend from air impermeable material 240 away from filter element downstream face 232. Spacers 282 may be integrally formed or permanently connected to air impermeable material 240 as shown, or filter housing downstream wall 256, or neither.

Referring to FIGS. 5A-B, each filter element 224 may include a discrete air impermeable member 240. An advantage of this design is that it may permit each filter element 224 to be removed for cleaning or replacement on an individual basis as required. Alternatively, two or more (or all) of filter elements 224 may share a common air impermeable member 240. FIG. 8 shows an example in which all of filter elements 224 share a common air impermeable

member 240, which extends over the air impermeable portion 236 of each filter element downstream face 232 (see also FIG. 11). An advantage of this design is that it allows air impermeable member 240 to connect the plurality of filter elements 224 in a fixed relative positional arrangement that provides the intended outside and inside gaps 244 and 248 (FIG. 6). This may mitigate a loss of separation efficiency or an increase in backpressure as a result of user error in positionally arranging filter elements 224 with the requisite spacing.

Referring to FIG. 11, filter housing 164 may be openable to provide access to filter member 160 inside. As shown, a wall of filter housing 164 (e.g. upstream wall 254 as shown, a sidewall 242, and/or downstream wall 256) may be movable (e.g. rotatably, slideably, or removably) from a closed position (FIG. 8) to an open position (FIG. 11). In the open position, user access to inspect, clean, and/or remove filter member 160 may be provided.

In alternative embodiments, filter housing 164 may be permanently closed. For example, filter housing 164 may form a disposable filter cartridge that is to be removed and replaced when needed. This may avoid user exposure to the dirt collect by the filter member 160 that is inside filter housing 164.

Alternatively or in addition to being disposable, filter member 160 may be cleaned without opening filter housing 164. FIGS. 12-14 illustrate an exemplary method of cleaning a filter member 160 within filter housing 164. Beginning with FIGS. 12-13, filter housing 164 may be oriented with filter housing air outlet 212 face-up. A cleaning fluid 320 (e.g. water) may be poured into filter housing air outlet 212. The cleaning fluid will flow through filter elements 224 in reverse from filter element outlets 208 to upstream faces 204. The cleaning fluid may entrain dirt that is within the porous filter media, and on upstream faces 204, and carry the dirt out of filter housing 164 through filter housing air inlet 260.

Turning to FIG. 14, a plunger (e.g. a rod) 284 may be inserted through filter housing air outlet 212 and used to push filter elements 224 so that filter elements 224 become compressed against filter housing downstream wall 256. This may be done to agitate the cleaning fluid within the filter elements 224 (e.g. to dislodge additional dirt), and/or to squeeze out cleaning fluid from the filter elements 224 (e.g. to expedite drying). In the illustrated example, filter elements 224 are connected by a common air impermeable member 240, and the plunger 284 presses on the air impermeable member 240 to compress filter elements 224 as a group. Alternatively, filter elements 224 may have individual air impermeable members 240, and may be compressed individually. Alternately, a rigid member may be provided inside the filter housing and moved by a plunger to compress the filter elements.

As shown in FIG. 15, a screen 286 may be provided for filter elements 224 to be compressed against. As compared with a liquid impermeable wall, screen 286 may permit cleaning fluid to expel from filter element 224 through the faces in contact with screen 286. In turn, screen 286 may permit the cleaning fluid to better clean the end faces of filter elements 224.

It will be appreciated that, in alternate embodiments, a cleaning fluid may be introduced through the air inlet port and a plunger may be inserted through the air inlet port.

As exemplified in FIG. 40B, the outlet passage downstream of outlet portion 208 (filter housing air outlet 212) may have a larger cross-sectional area in a direction transverse to a direction of air flow therethrough (e.g., transverse

to flow direction **308**) than the cross-sectional area of outlet portion **208** in a direction transverse to flow direction **308**. For example, as exemplified in FIG. **40B**, the diameter of the filter housing air outlet **212** may be the same as the diameter of filter housing **164**. Alternately, as exemplified in FIGS. **40C-40E**, a flange **310** may be provided at the outlet end of the filter element **164**. Accordingly, the cross-sectional area in a direction transverse to the direction of air flow through the filter housing air outlet **212** may be increased and may be larger than the diameter of filter housing **164**.

It will be appreciated that the filter may be spaced from the inner surface of the sidewalls of the filter housing **164** by any means. For example, pipe **245** (see for example FIG. **40A**), may secure filter element **224** in position in filter housing **164**. Alternately, or in addition ribs **166** may be provided on the inner surface of the sidewall of filter housing. As exemplified, ribs **166** extend continuously axially in the direction of the sidewall **167** of filter housing **164**. As exemplified, ribs **166** are spaced apart equidistantly around sidewall **167**. It will be appreciated that ribs **166** may be spaced apart by different amounts; they need not extend continuously along the length of the sidewall **167** but may be a plurality of discrete members extending inwardly from sidewall **167** to assist in holding filter element **224** in position.

As exemplified in FIGS. **40D**, **40F**, **40H**, **40J**, **40L**, **40N**, and **40Q**. Filter housing **164** may include a lid **162**, which may be openable. Optionally, lid may have one or more ribs **163** that extend from lid **162** downwardly to upper surface **205** of filter element **224** to assist in holding filter element **224** in position in the filter housing **164**. Ribs **163** are spaced apart equidistantly around lid **162**. It will be appreciated that ribs **163** may be spaced apart by different amounts; they need not extend continuously along the radial length of the lid **162** but may be a plurality of discrete members extending inwardly from lid **162** to assist in holding filter element **224** in position. Ribs **163** may overlie less than 10%, less than 5% or less than 3% of upper surface **205** of filter element **224**.

Distributed Filter Elements

As demonstrated by the examples illustrated in FIGS. **16-23**, there is great flexibility of design in the shape and size of filter member **160**, and the number and arrangement of filter elements **224** therein. Turning to FIG. **26**, this design flexibility may permit surface cleaning apparatus **100** to accommodate two or more filter members **160** positioned in parallel in the air flow path **124**. For example, apparatus **100** may include two or more pre-motor filter members **160** positioned in parallel in the air flow path **124** between air treatment member air outlet **188** and suction motor air inlet **316**. In some embodiments, filter members **160** may be sized and shaped to occupy locations in apparatus **100** that may have otherwise been unused void space. An advantage of occupying otherwise unused space with additional filter member(s) **160** is that it may provide greater dirt separation efficiency and less backpressure, all else being equal.

As exemplified in FIG. **26**, two filter members **160** are provided, one above air treatment member **116** and one above handle **104**. As shown, air exiting air treatment member **116** may divide into two parallel air flow paths **1241** and **1242**. Air flow path **1241** is shown extending across pre-motor filter member **1601** from air treatment member air outlet **188** to suction motor air inlet **316**, and air flow path **1242** is shown extending across pre-motor filter member **1602** from air treatment member air outlet **188** to suction motor air inlet **316**.

While the above description provides examples of the embodiments, it will be appreciated that some features and/or functions of the described embodiments are susceptible to modification without departing from the spirit and principles of operation of the described embodiments. Accordingly, what has been described above has been intended to be illustrative of the invention and non-limiting and it will be understood by persons skilled in the art that other variants and modifications may be made without departing from the scope of the invention as defined in the claims appended hereto. The scope of the claims should not be limited by the preferred embodiments and examples, but should be given the broadest interpretation consistent with the description as a whole.

The invention claimed is:

1. A surface cleaning apparatus comprising:

- (a) an air flow path extending from a dirty air inlet to a clean air outlet with an air treatment member and a suction motor positioned in the air flow path; and,
- (b) a filter housing having an axially extending filter chamber having an inlet end and an outlet end, the filter housing having an air impermeable wall extending from the outlet end towards the inlet end of the filter housing; and,
- (c) a filter comprising a porous filter media positioned in the filter housing, the porous filter media having an outer upstream surface and an inner outlet passage defining a downstream surface and having an axial flow direction, the outlet passage terminating at an outlet port provided in an end face of the porous filter media, the outer upstream surface abutting the air impermeable wall.

2. The surface cleaning apparatus of claim 1 wherein the porous filter media has an absence of a support member inside the outlet passage.

3. The surface cleaning apparatus of claim 1 wherein the air impermeable wall has a greater axial length than a thickness of the porous filter media from the inner outlet passage to the outer upstream wall in a plane transverse to the axial flow direction.

4. The surface cleaning apparatus of claim 1 wherein a distance from an axially inward end of the air impermeable wall to the outlet port is greater than 125% a thickness of the porous filter media from the inner outlet passage to the outer upstream wall in a plane transverse to the axial flow direction.

5. The surface cleaning apparatus of claim 1 wherein the surface area of the outer upstream surface of the porous filter media is at least as great as a cross-sectional area of the filter housing air inlet in a direction transverse to a direction of flow through the filter housing air inlet.

6. The surface cleaning apparatus of claim 1 wherein the end face is provided with an air impermeable material surrounding the outlet port.

7. The surface cleaning apparatus of claim 6 wherein the air impermeable material surrounding the outlet port is attached to the end face of the porous filter media.

8. The surface cleaning apparatus of claim 6 wherein the air impermeable material surrounding the outlet port comprises an air outlet end wall of the filter housing.

9. The surface cleaning apparatus of claim 1 wherein a plurality of ribs are provided at the outlet end of the filter chamber.

10. The surface cleaning apparatus of claim 9 wherein a distance from an axially inward end of the air impermeable wall to the outlet port is at least as great as a thickness of the

porous filter media from the inner outlet passage to the outer upstream wall in a plane transverse to the axial flow direction.

11. The surface cleaning apparatus of claim 1 wherein the porous filter media comprises an axially extending annular filter member having a first end, an axially spaced apart second end and an inner open volume extending axially from the first end to the opposed second end, and an separately formed insert is provided in and closes the first end of the open volume.

12. The surface cleaning apparatus of claim 6 wherein the insert is made of a porous filter media.

13. A surface cleaning apparatus comprising:

(a) an air flow path extending from a dirty air inlet to a clean air outlet with an air treatment member and a suction motor positioned in the air flow path; and,

(b) a filter housing having an axially extending filter chamber having an inlet end and an outlet end spaced from the inlet end in an axial direction, the filter housing having an air impermeable wall extending from the outlet end towards the inlet end of the filter housing; and,

(c) a filter comprising a porous filter media positioned in the filter housing, the porous filter media having an outer upstream surface and an outlet portion provided in an end face of the porous filter media, the outer upstream surface abutting the air impermeable wall.

14. The surface cleaning apparatus of claim 13 wherein the air impermeable wall has a greater axial length than a quarter of a thickness of the porous filter media in a plane transverse to the axial direction.

15. The surface cleaning apparatus of claim 13 wherein the air impermeable wall has a greater axial length than a third of a thickness of the porous filter media in a plane transverse to the axial direction.

16. The surface cleaning apparatus of claim 13 wherein the surface area of the outer upstream surface of the porous filter media is at least as great as a cross-sectional area of the

filter housing air inlet in a direction transverse to a direction of flow through the filter housing air inlet.

17. The surface cleaning apparatus of claim 13 wherein the end face is provided with an air impermeable material surrounding the outlet portion.

18. The surface cleaning apparatus of claim 17 wherein the air impermeable material surrounding the outlet portion is attached to the end face of the porous filter media.

19. The surface cleaning apparatus of claim 17 wherein the air impermeable material surrounding the outlet portion comprises an air outlet end wall of the filter housing.

20. The surface cleaning apparatus of claim 13 wherein a plurality of ribs are provided at the outlet end of the filter chamber.

21. The surface cleaning apparatus of claim 20 wherein a distance from an axially inward end of the air impermeable wall to the outlet port is at least as great as a thickness of the porous filter media from the inner outlet passage to the outer upstream wall in a plane transverse to the axial flow direction.

22. The surface cleaning apparatus of claim 13 wherein the porous filter media comprises an axially extending annular filter member having a first end, an axially spaced apart second end and an inner open volume extending axially from the first end to the opposed second end, and an separately formed insert is provided in and closes the first end of the open volume.

23. The surface cleaning apparatus of claim 22 wherein the insert is made of a porous filter media.

24. A porous filter media for a surface cleaning apparatus comprising an axially extending annular filter member having a first end, an axially spaced apart second end and an inner open volume extending axially from the first end to the opposed second end, and an separately formed insert is provided in and closes the first end of the open volume.

25. The porous filter media of claim 24 wherein the insert is made of a porous filter media.

* * * * *