



US011154169B2

(12) **United States Patent**  
**Conrad**

(10) **Patent No.:** **US 11,154,169 B2**  
(45) **Date of Patent:** **\*Oct. 26, 2021**

(54) **CYCLONIC AIR TREATMENT MEMBER AND SURFACE CLEANING APPARATUS INCLUDING THE SAME**

*A47L 9/1683* (2013.01); *B01D 45/16* (2013.01); *B04C 5/185* (2013.01); *B04C 5/26* (2013.01); *B04C 9/00* (2013.01); *B04C 2009/008* (2013.01)

(71) Applicant: **OMACHRON INTELLECTUAL PROPERTY INC.**, Hampton (CA)

(58) **Field of Classification Search**  
CPC ..... *A47L 9/1608*; *A47L 9/165*; *A47L 5/24*; *A47L 9/1658*; *A47L 9/1683*; *A47L 9/1641*; *A47L 9/2884*; *A47L 9/1666*; *A47L 9/12*; *A47L 9/106*; *A47L 5/28*; *B04C 5/185*; *B04C 9/00*; *B04C 5/26*; *B04C 2009/008*; *B04C 3/06*

(72) Inventor: **Wayne Ernest Conrad**, Hampton (CA)

(73) Assignee: **Omachron Intellectual Property Inc.**, Hampton (CA)

See application file for complete search history.

(\*) Notice: Subject to any disclaimer, the term of this patent is extended or adjusted under 35 U.S.C. 154(b) by 0 days.

(56) **References Cited**

This patent is subject to a terminal disclaimer.

U.S. PATENT DOCUMENTS

(21) Appl. No.: **16/901,945**

2,119,478 A \* 5/1938 Whiton, Jr. .... B04C 11/00  
96/397  
2,461,677 A \* 2/1949 Burdock ..... B04C 5/28  
55/348

(22) Filed: **Jun. 15, 2020**

(Continued)

(65) **Prior Publication Data**

US 2020/0305668 A1 Oct. 1, 2020

*Primary Examiner* — Dung H Bui

(74) *Attorney, Agent, or Firm* — Philip C. Mendes da Costa; Bereskin & Parr LLP/ S.E.N.C.R.L., s.r.l.

**Related U.S. Application Data**

(63) Continuation-in-part of application No. 16/529,430, filed on Aug. 1, 2019, now Pat. No. 11,006,799, (Continued)

(57) **ABSTRACT**

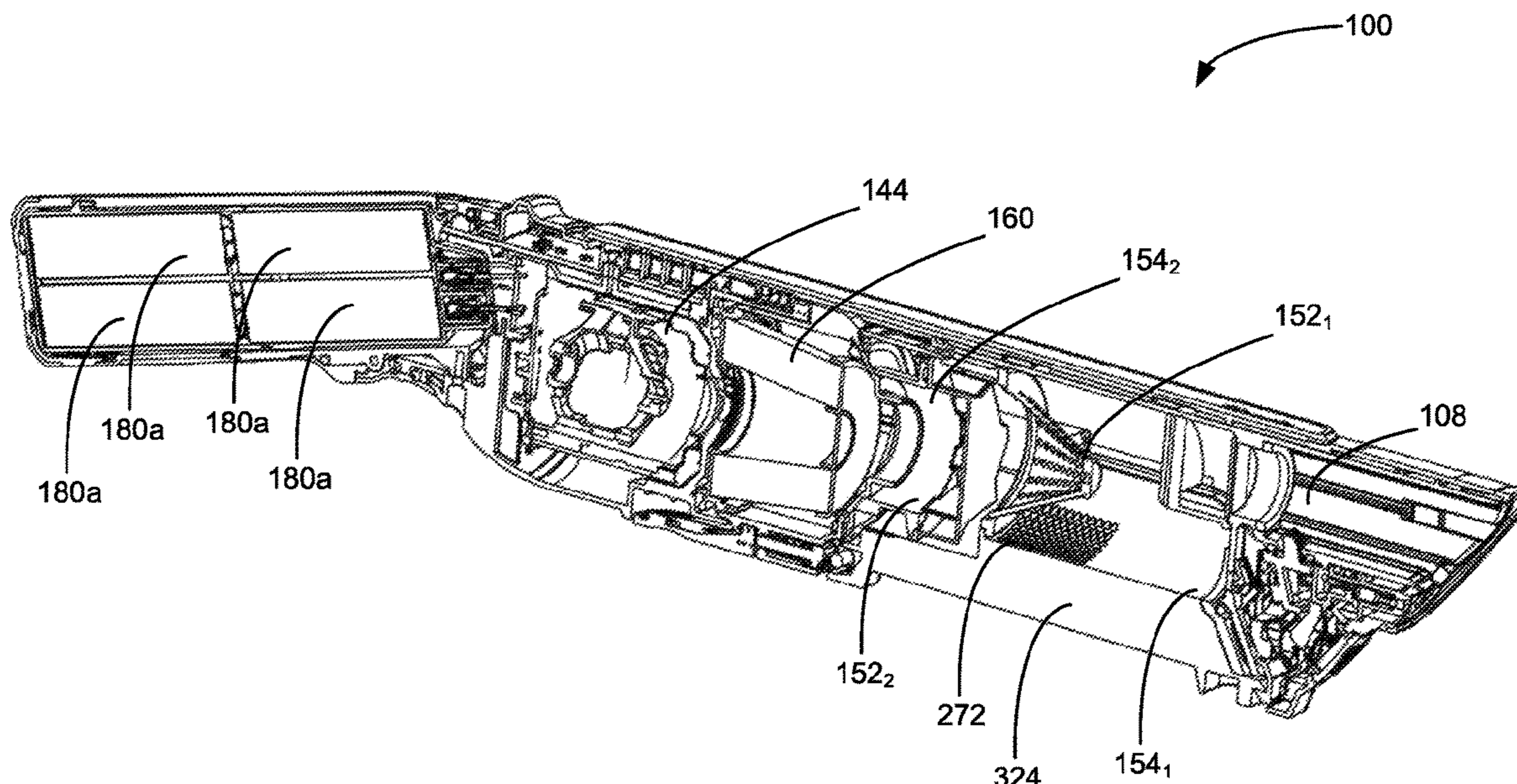
(51) **Int. Cl.**  
*B01D 45/00* (2006.01)  
*A47L 9/16* (2006.01)

(Continued)

A surface cleaning apparatus comprising a first cyclonic cleaning stage having a first cyclone chamber and a first dirt collection chamber external to the first cyclone chamber. The first cyclone chamber has a cyclone first end, an opposed cyclone second end, a cyclone sidewall extending between the cyclone first end and the cyclone second end, a cyclone air inlet, a cyclone air outlet, a cyclone dirt outlet in communication with the first dirt collection chamber and a cyclone longitudinal axis extending from the cyclone first end to the cyclone second end. The dirt outlet comprises a plurality of apertures.

(52) **U.S. Cl.**  
CPC ..... *A47L 9/1608* (2013.01); *A47L 5/24* (2013.01); *A47L 9/165* (2013.01); *A47L 9/1641* (2013.01); *A47L 9/1658* (2013.01);

**20 Claims, 57 Drawing Sheets**



**Related U.S. Application Data**

which is a continuation-in-part of application No. 16/101,770, filed on Aug. 13, 2018, now Pat. No. 11,013,384, application No. 16/901,945, which is a continuation-in-part of application No. 16/201,649, filed on Nov. 27, 2018, now Pat. No. 10,882,059.

(60) Provisional application No. 62/734,603, filed on Sep. 21, 2018.

(51) **Int. Cl.**

*A47L 5/24* (2006.01)  
*B04C 5/185* (2006.01)  
*B04C 9/00* (2006.01)  
*B04C 5/26* (2006.01)  
*B01D 45/16* (2006.01)

(56) **References Cited**

U.S. PATENT DOCUMENTS

2,643,737 A \* 6/1953 Bowers ..... B04C 5/28  
 55/349  
 2,734,630 A \* 2/1956 Van Der Wal ..... B04C 5/081  
 209/728  
 2,867,290 A \* 1/1959 McGrane ..... B04C 5/28  
 55/344  
 6,334,234 B1 \* 1/2002 Conrad ..... A47L 5/30  
 15/347  
 6,406,505 B1 \* 6/2002 Oh ..... A47L 9/1666  
 55/337  
 7,811,349 B2 \* 10/2010 Nguyen ..... A47L 9/1658  
 55/426  
 8,282,697 B2 \* 10/2012 Oh ..... A47L 9/1641  
 55/345  
 2002/0011053 A1 \* 1/2002 Oh ..... B01D 50/002  
 55/426  
 2002/0134238 A1 \* 9/2002 Conrad ..... B03C 3/017  
 95/79  
 2003/0106182 A1 \* 6/2003 Lee ..... A47L 9/165  
 15/353  
 2003/0150324 A1 \* 8/2003 West ..... B01D 17/0211  
 95/268  
 2004/0103495 A1 \* 6/2004 Oh ..... B04C 5/187  
 15/352  
 2005/0252179 A1 \* 11/2005 Oh ..... A47L 9/1683  
 55/337

2006/0042039 A1 \* 3/2006 McDowell ..... A47L 5/362  
 15/353  
 2006/0162298 A1 \* 7/2006 Oh ..... A47L 7/0004  
 55/337  
 2006/0230719 A1 \* 10/2006 Han ..... A47L 9/1625  
 55/345  
 2007/0079585 A1 \* 4/2007 Oh ..... B04C 5/13  
 55/345  
 2007/0209334 A1 \* 9/2007 Conrad ..... A47L 9/1608  
 55/337  
 2007/0289267 A1 \* 12/2007 Makarov ..... A47L 9/1641  
 55/345  
 2008/0190080 A1 \* 8/2008 Oh ..... A47L 9/1683  
 55/343  
 2009/0113861 A1 \* 5/2009 Seo ..... A47L 9/1633  
 55/429  
 2009/0181841 A1 \* 7/2009 Conrad ..... B04C 5/28  
 494/32  
 2010/0139033 A1 \* 6/2010 Makarov ..... A47L 9/1641  
 15/353  
 2010/0213118 A1 \* 8/2010 Tandon ..... B04C 5/185  
 210/512.2  
 2010/0275561 A1 \* 11/2010 Lundquist ..... B04C 3/00  
 55/456  
 2012/0297740 A1 \* 11/2012 Cheng ..... B01D 46/10  
 55/326  
 2013/0031878 A1 \* 2/2013 Menssen ..... F02M 35/0223  
 55/345  
 2013/0152522 A1 \* 6/2013 Stippich ..... B01J 8/0055  
 55/398  
 2013/0247764 A1 \* 9/2013 Kvamsdal ..... B01D 45/16  
 96/188  
 2013/0255203 A1 \* 10/2013 Muenkel ..... B01D 46/0021  
 55/337  
 2013/0327002 A1 \* 12/2013 Ackermann ..... B04C 3/00  
 55/327  
 2016/0008741 A1 \* 1/2016 Beg ..... B04C 5/081  
 96/182  
 2016/0206169 A1 \* 7/2016 Hyun ..... A47L 9/165  
 2018/0043292 A1 \* 2/2018 Carroll ..... B01D 45/16  
 2019/0001348 A1 \* 1/2019 Ingram ..... B01D 45/12  
 2019/0003388 A1 \* 1/2019 Atsuchi ..... F02C 7/052  
 2019/0091703 A1 \* 3/2019 Hyun ..... A47L 9/165  
 2019/0099766 A1 \* 4/2019 Krishnamurthy ..... B04C 3/04  
 2019/0277227 A1 \* 9/2019 Larson ..... B01D 46/48  
 2020/0009487 A1 \* 1/2020 Vanaudenhove .....  
 F02M 35/10262

\* cited by examiner

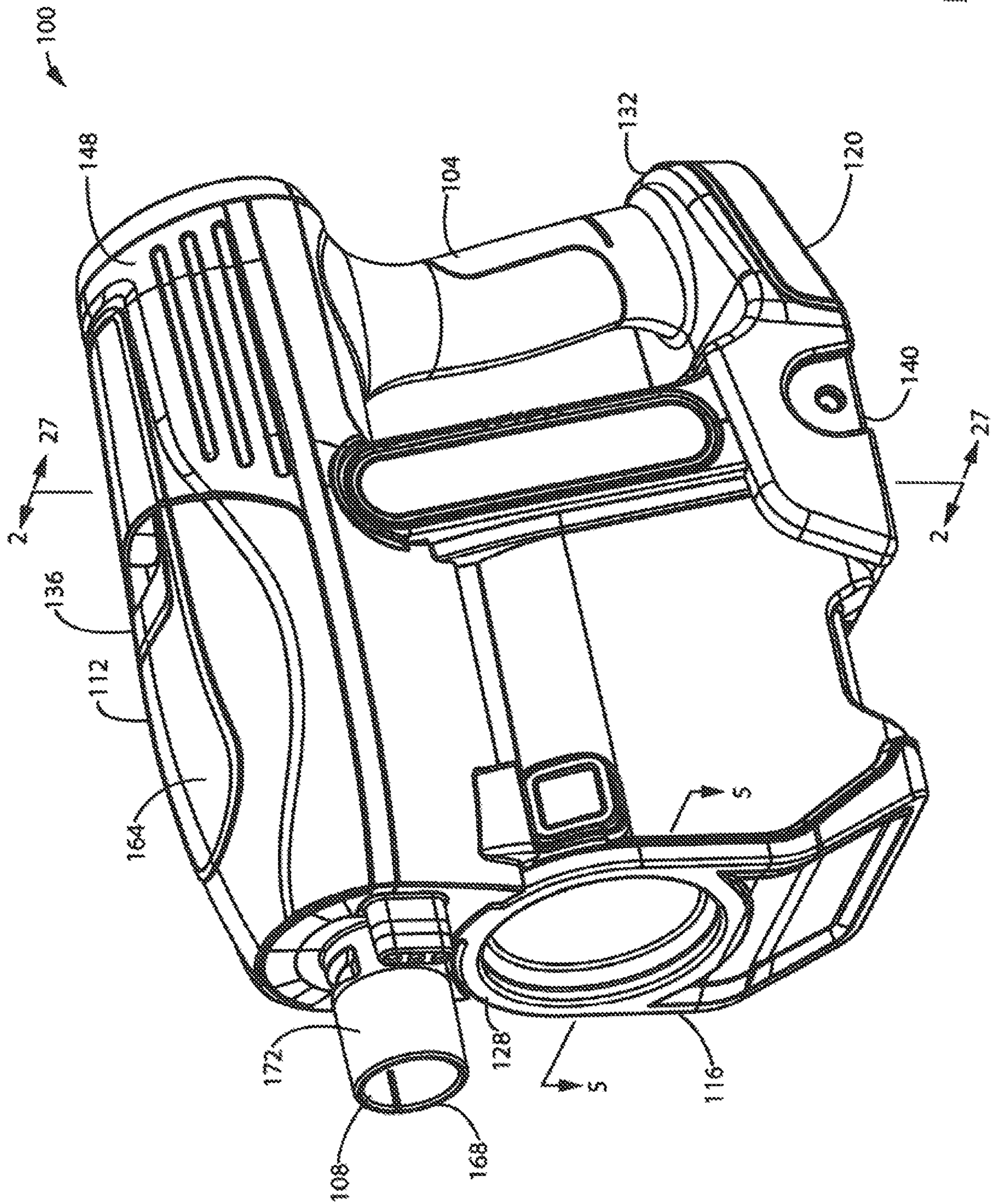


FIG. 1

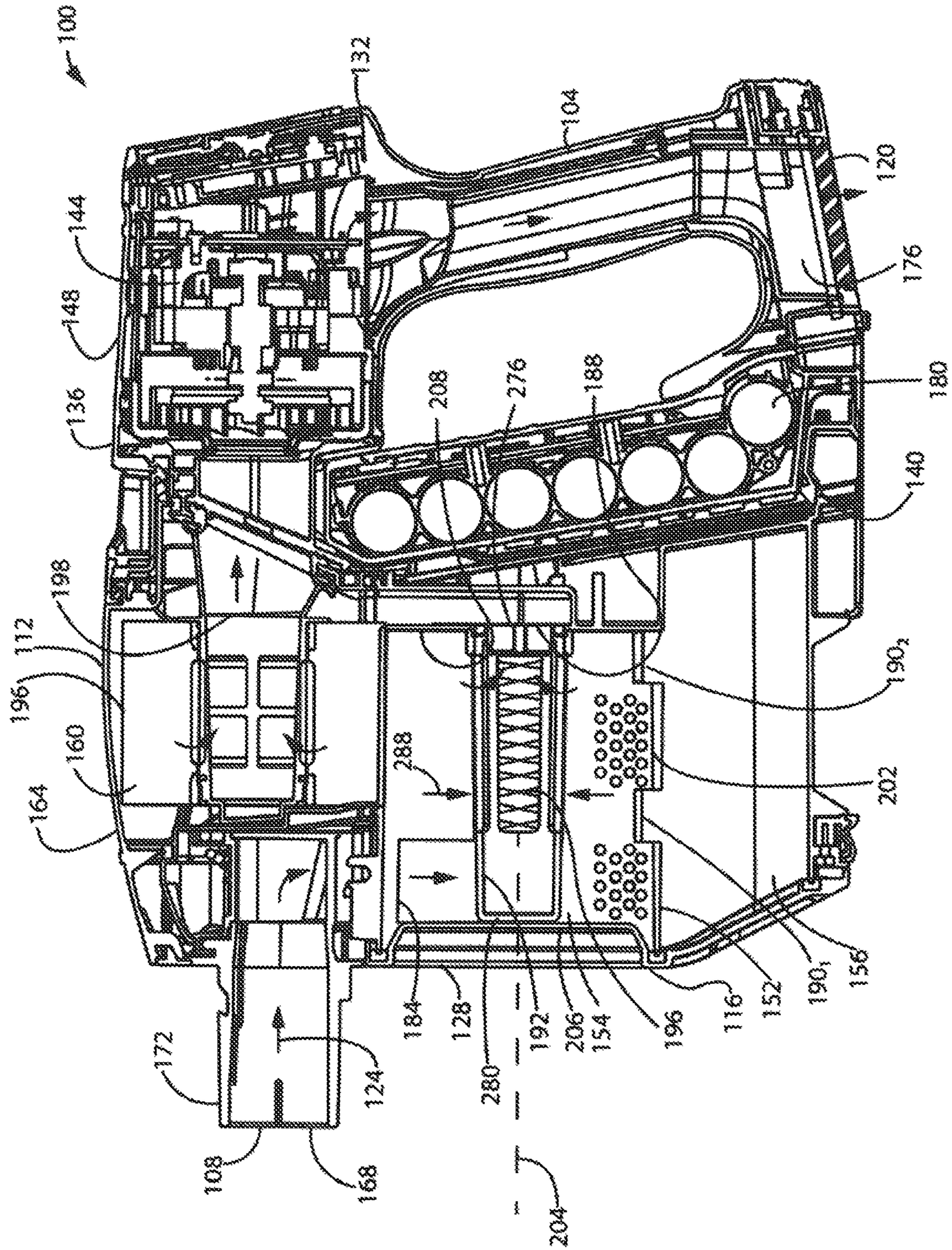


FIG. 2

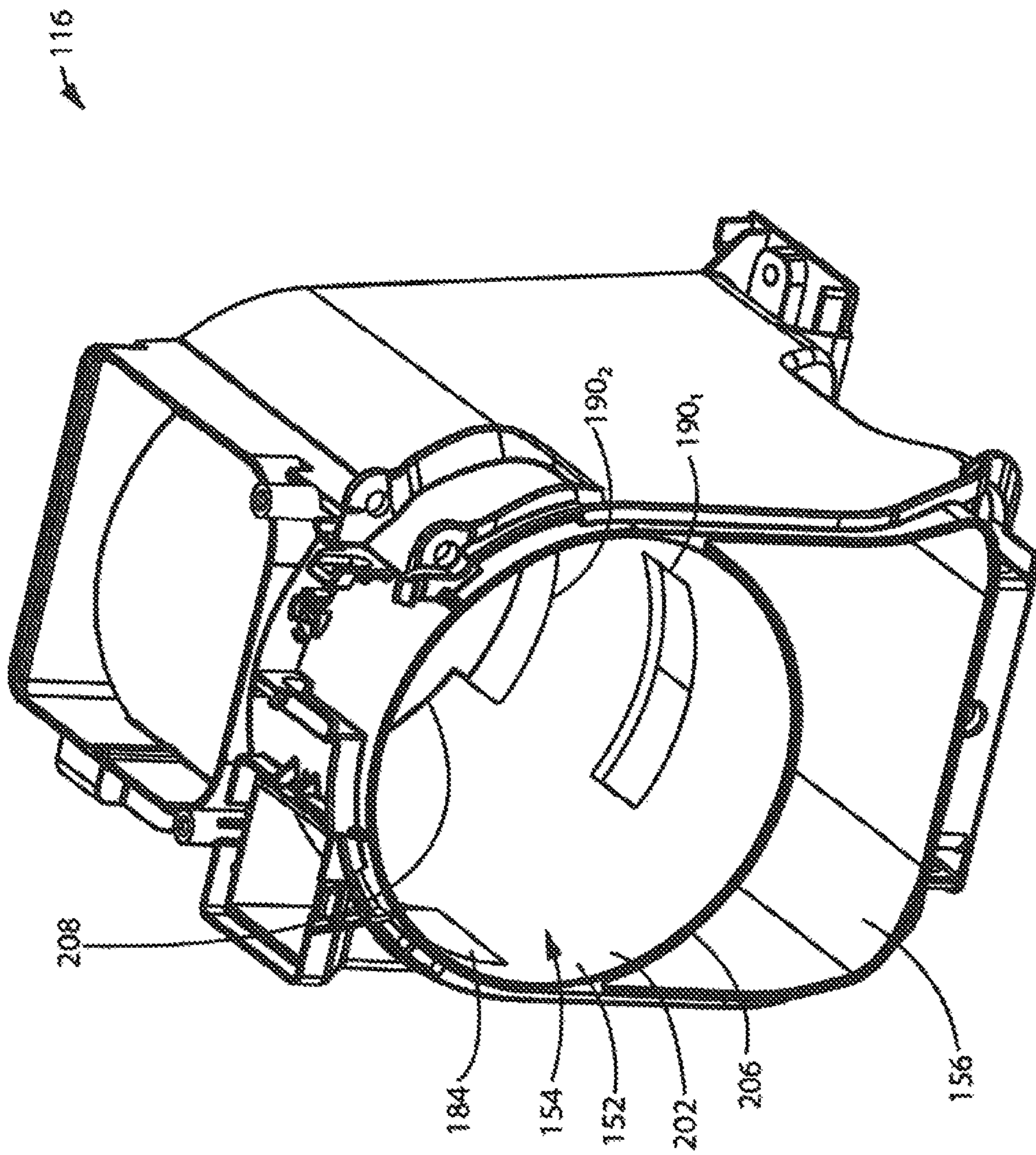


FIG. 3

116

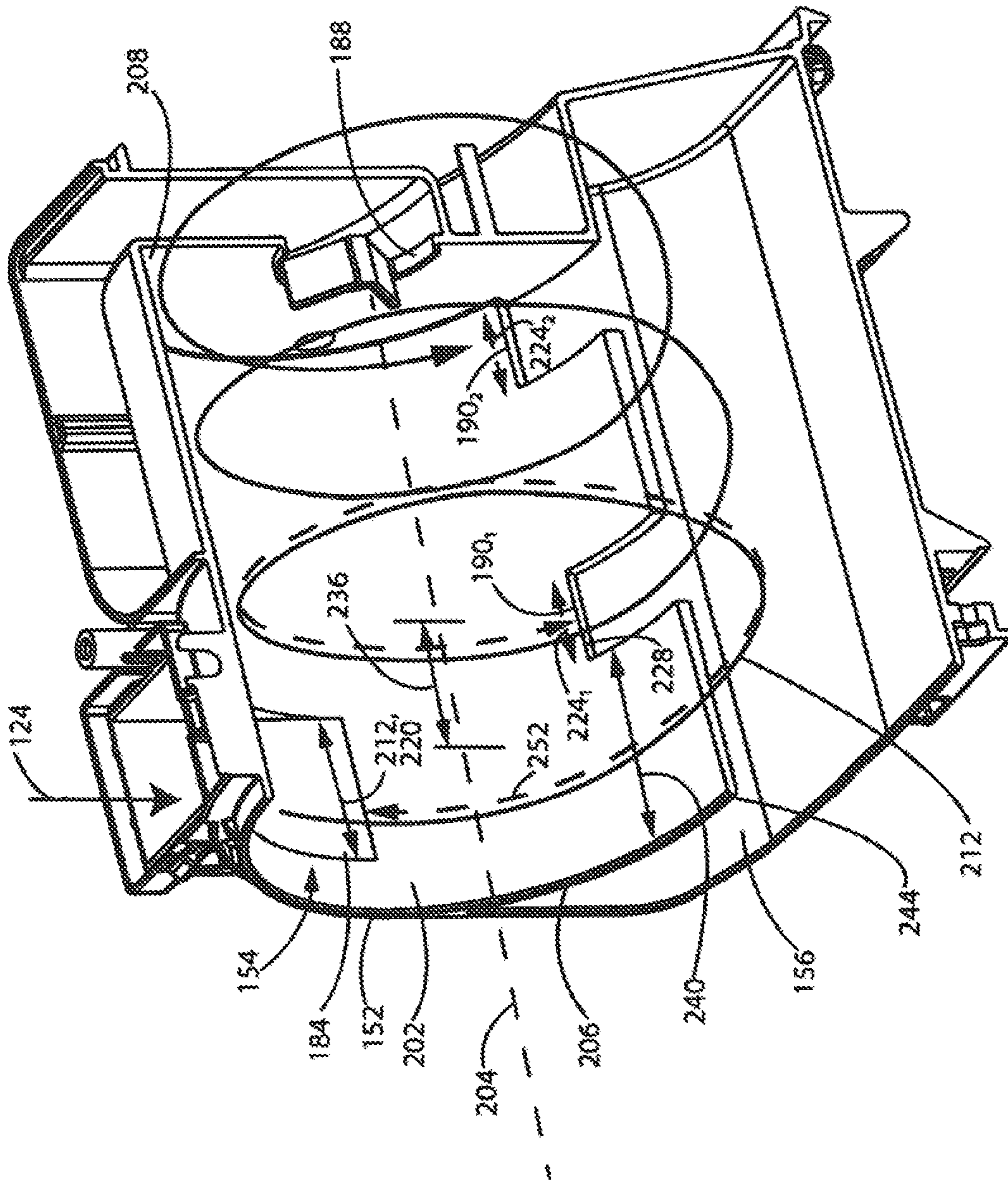


FIG. 4

116

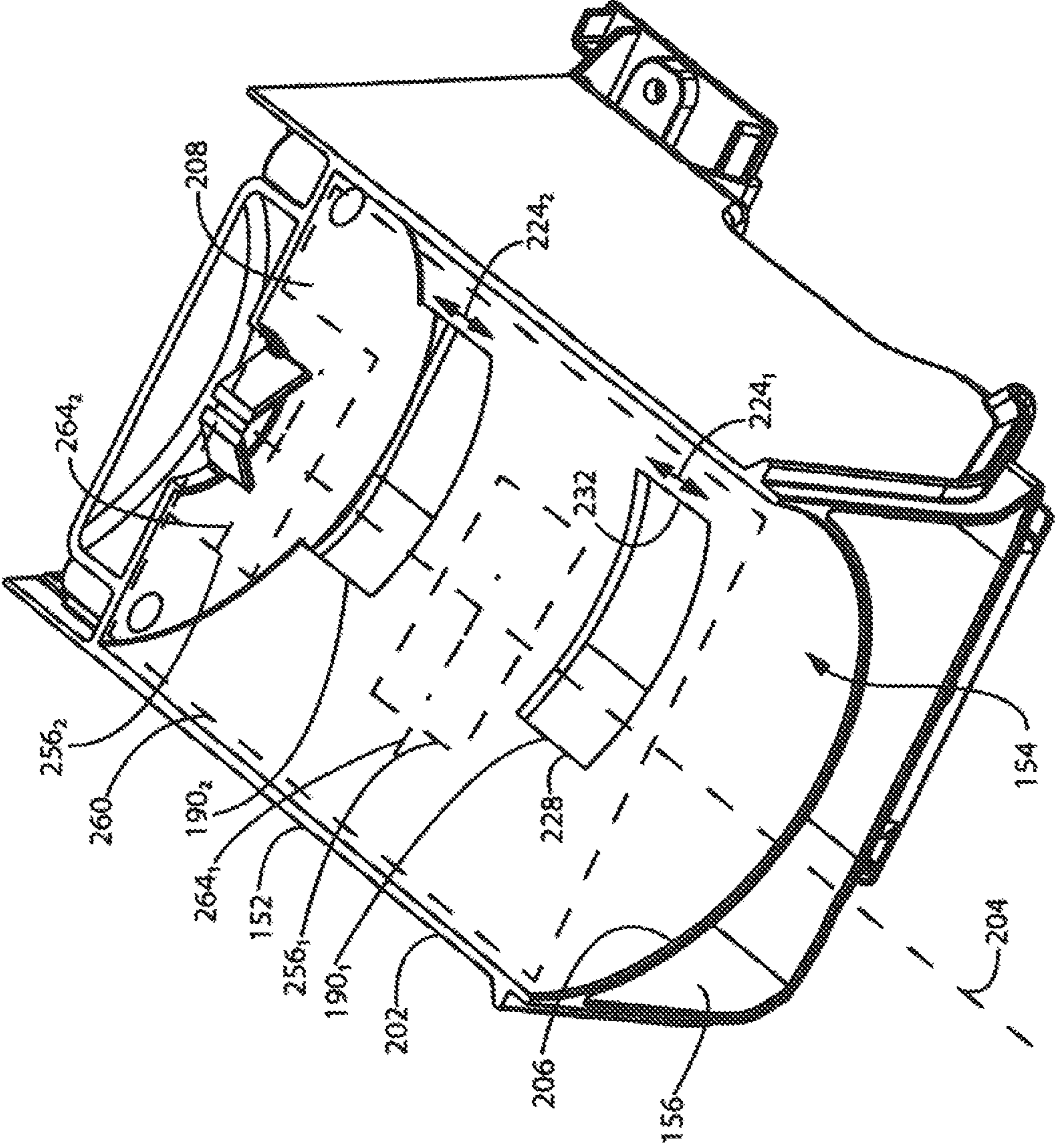


FIG. 5

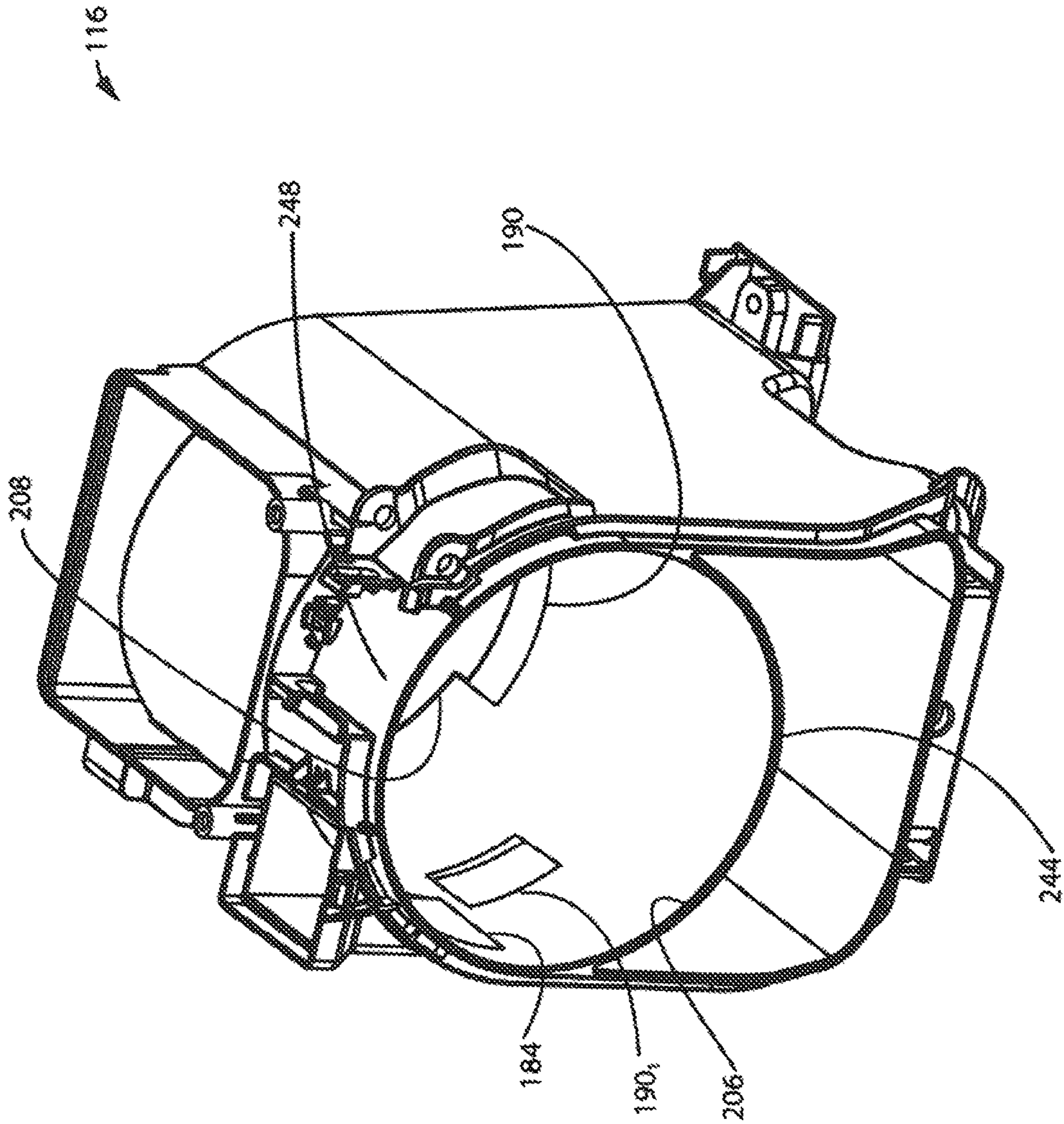


FIG. 6



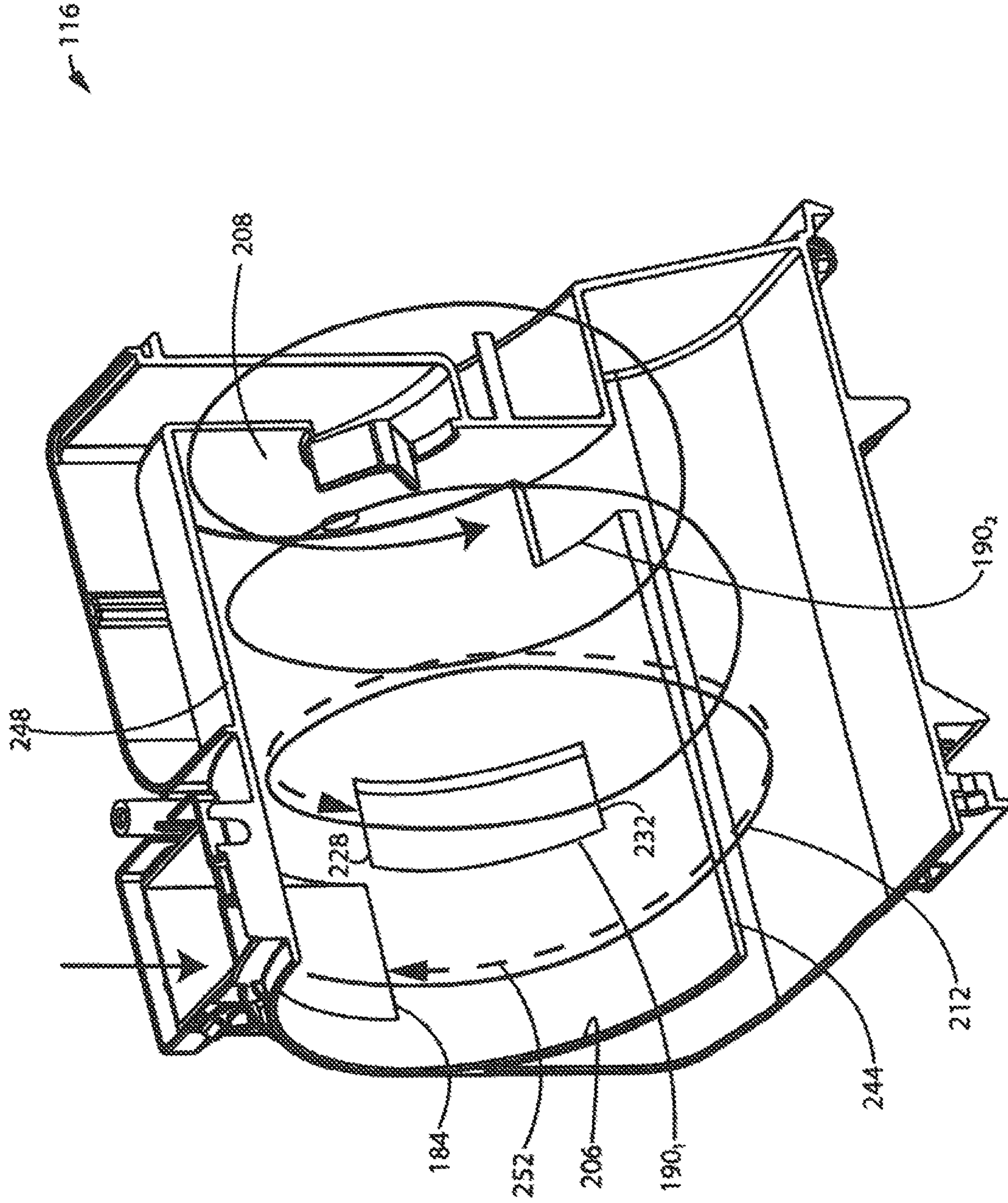


FIG. 7

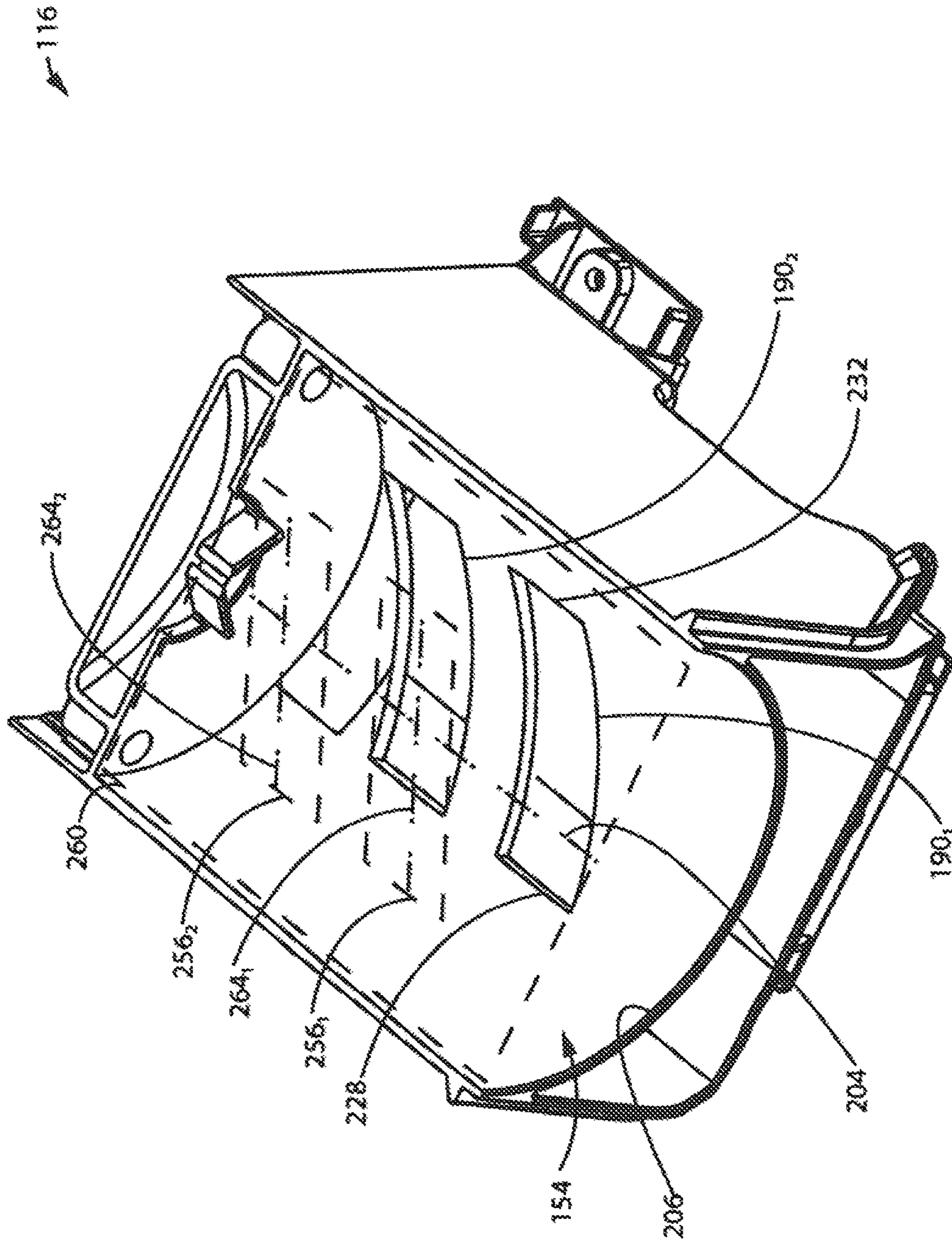


FIG. 8

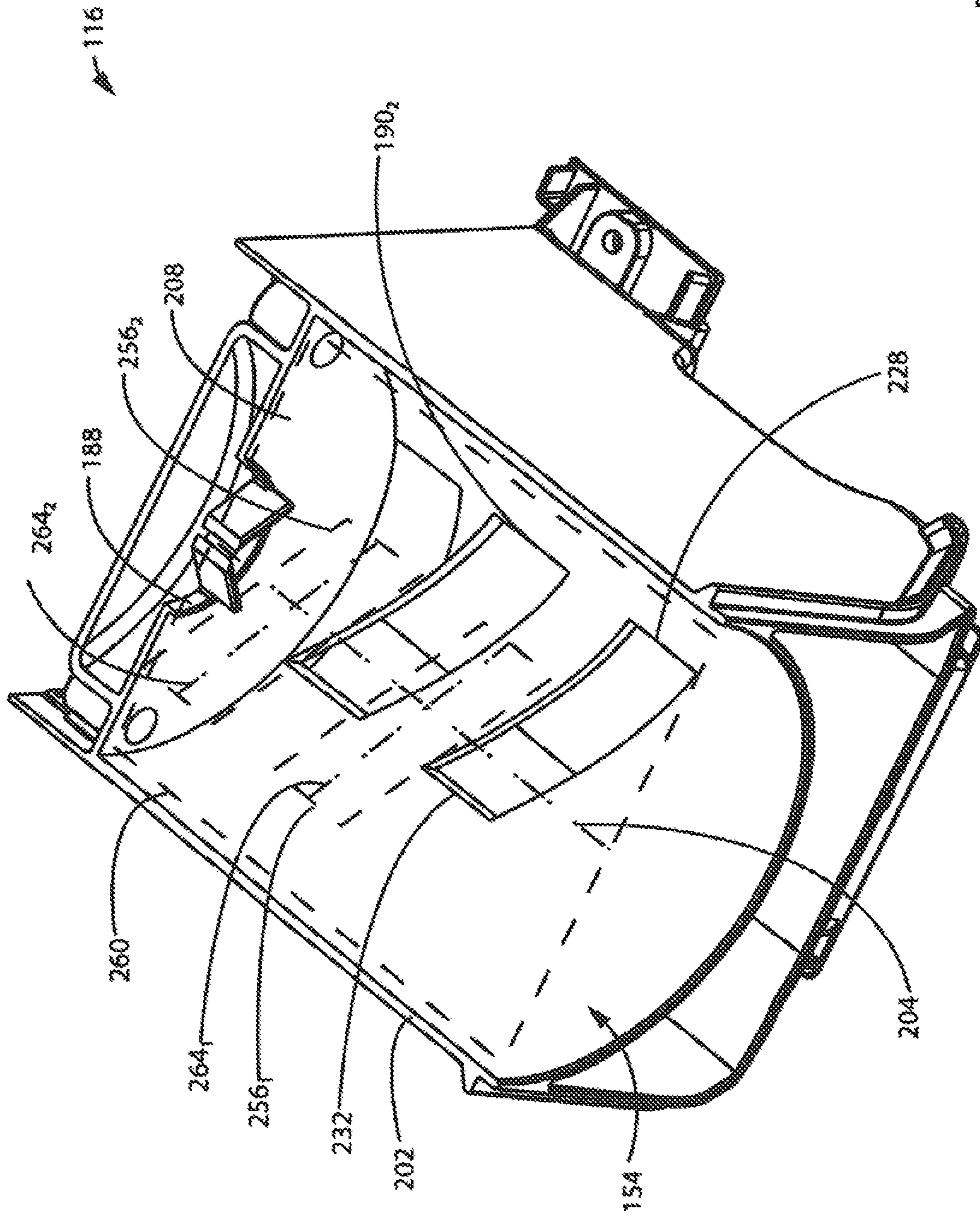


FIG. 9

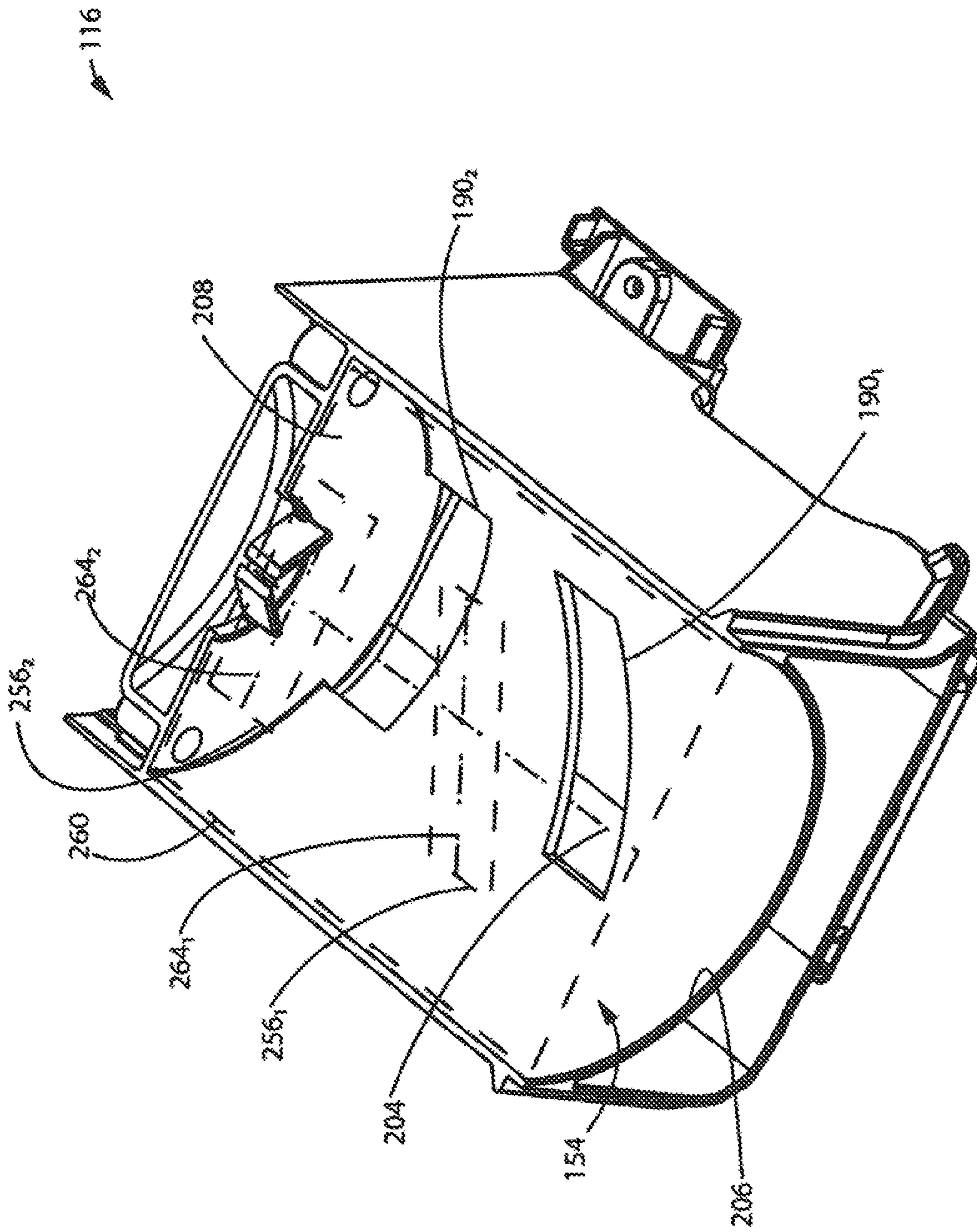


FIG. 10

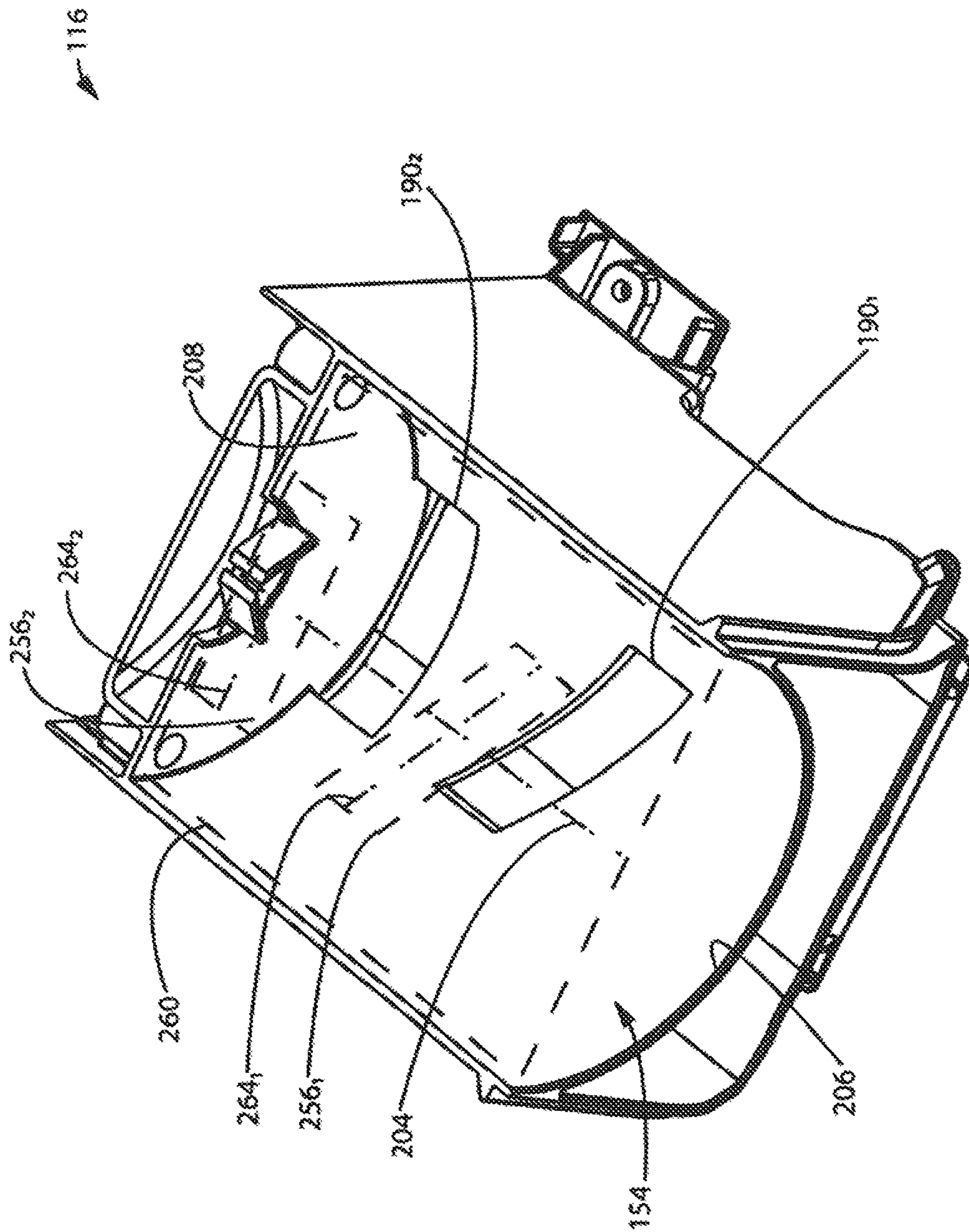


FIG. 11

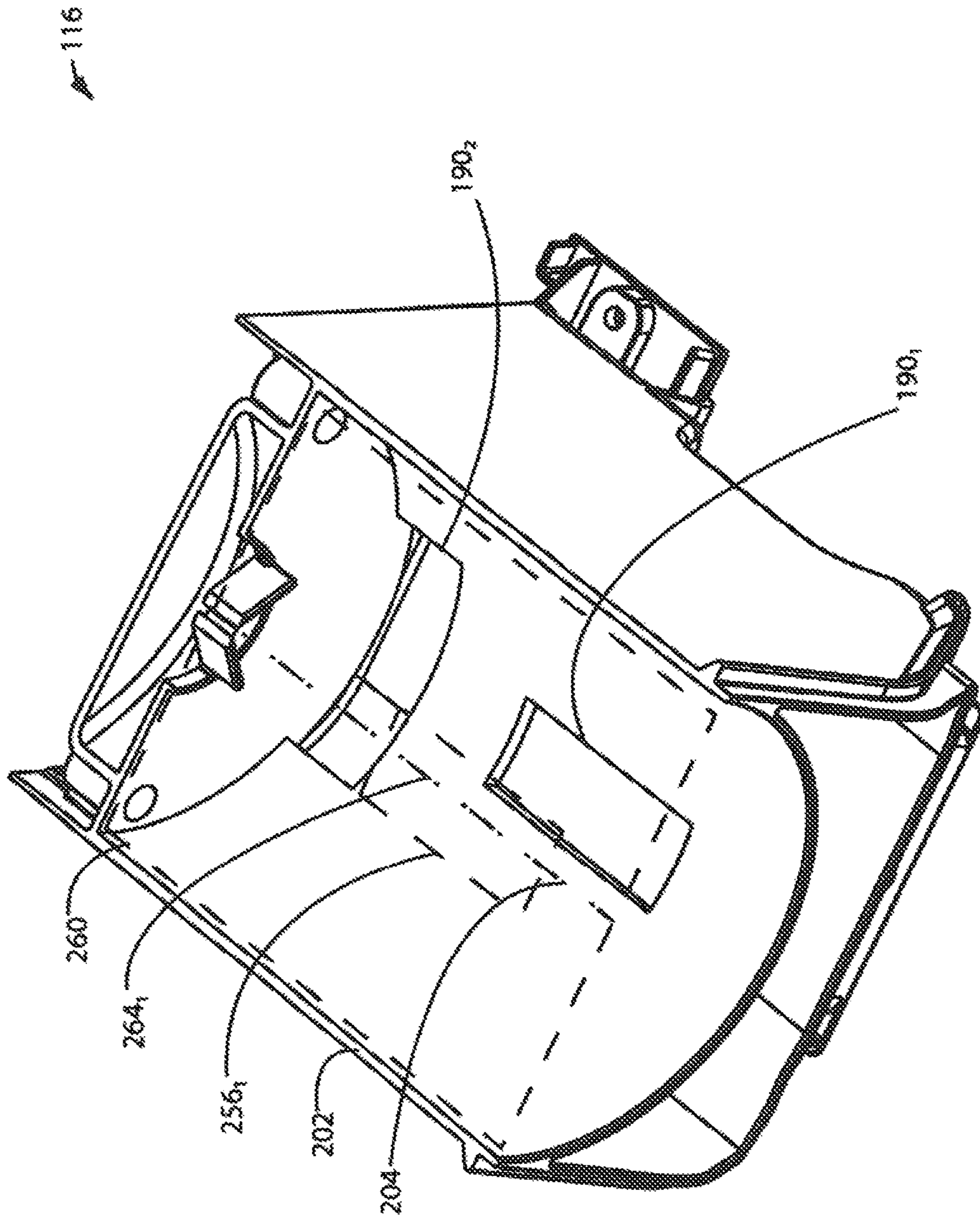


FIG. 12

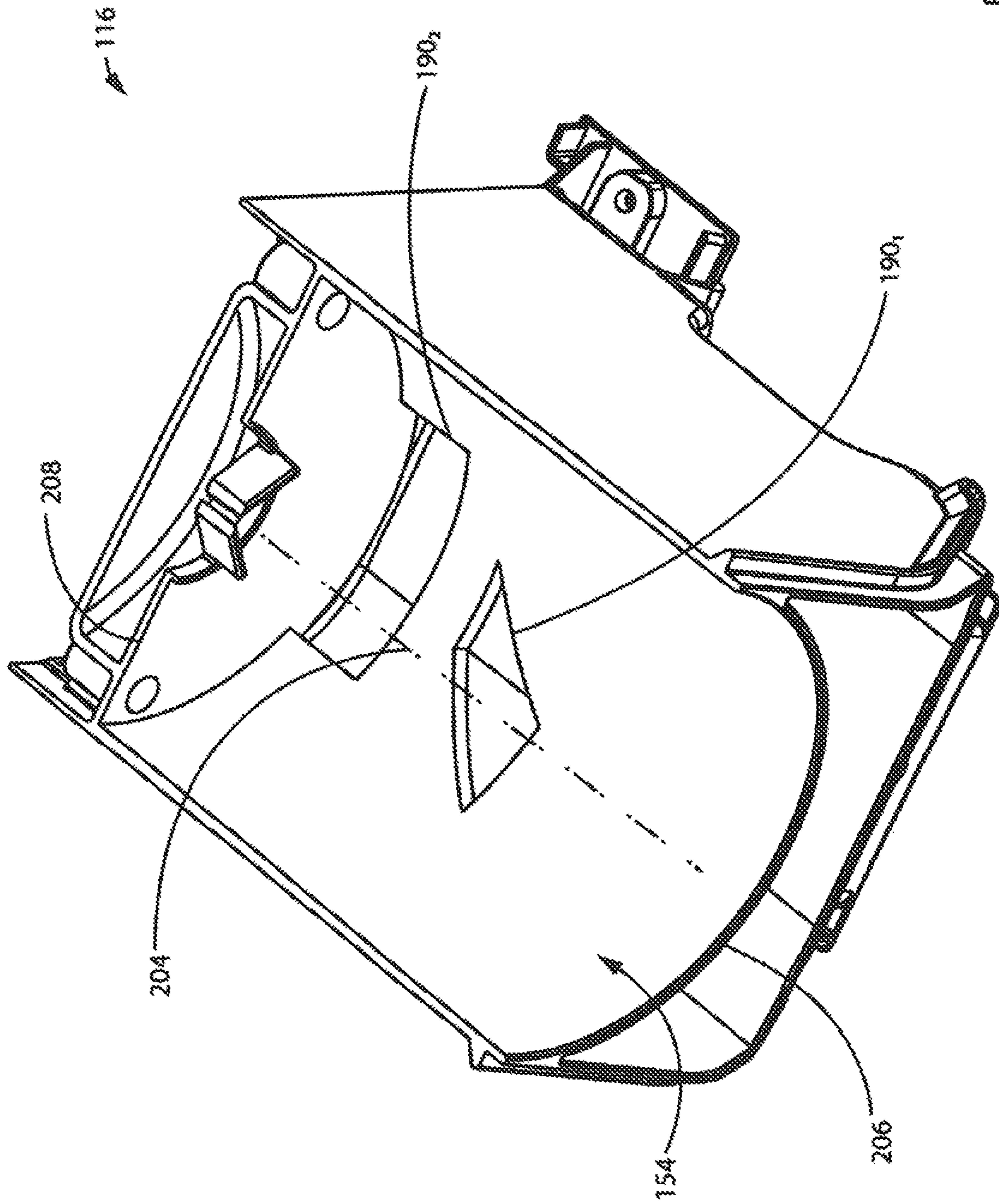


FIG. 13

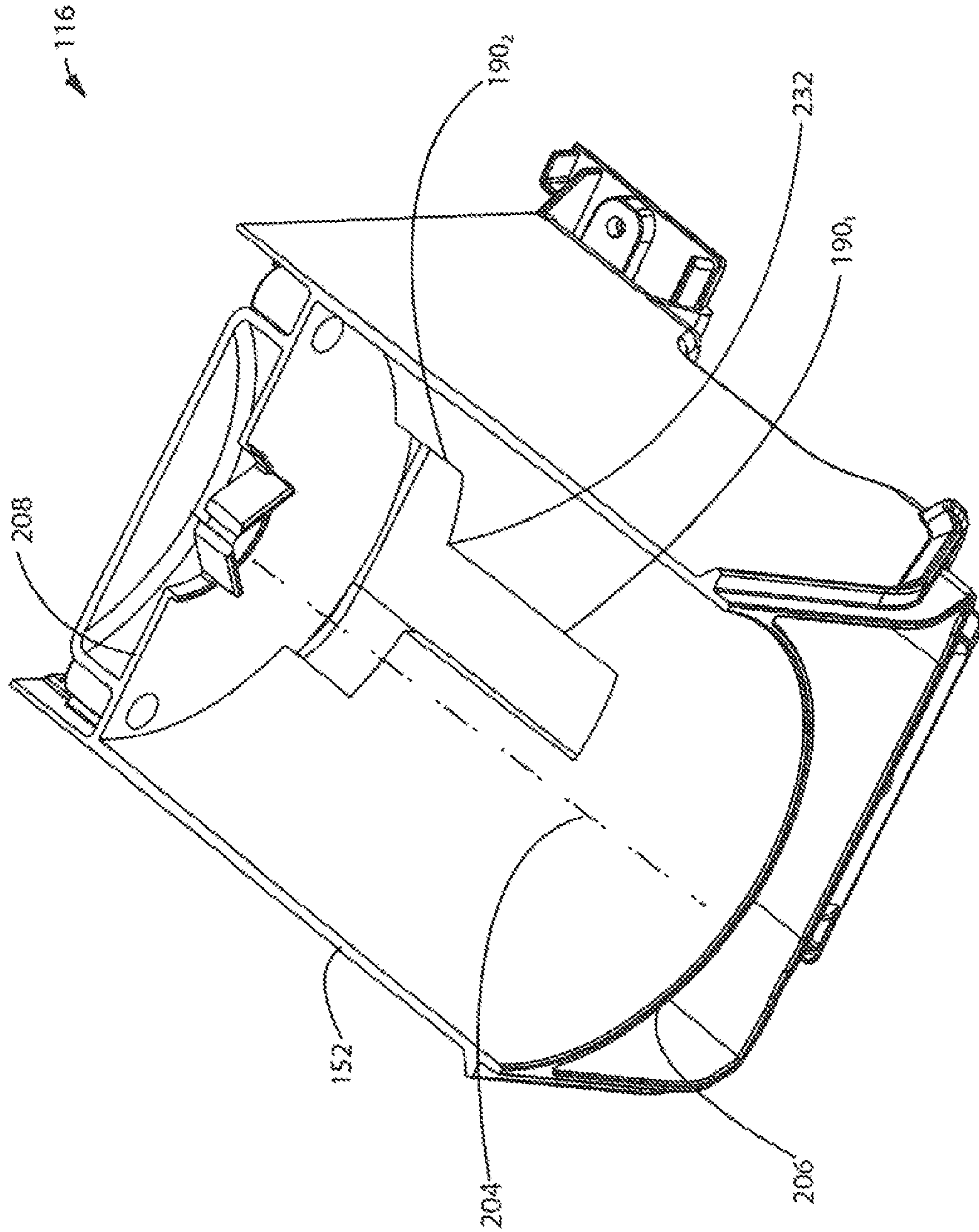


FIG. 14



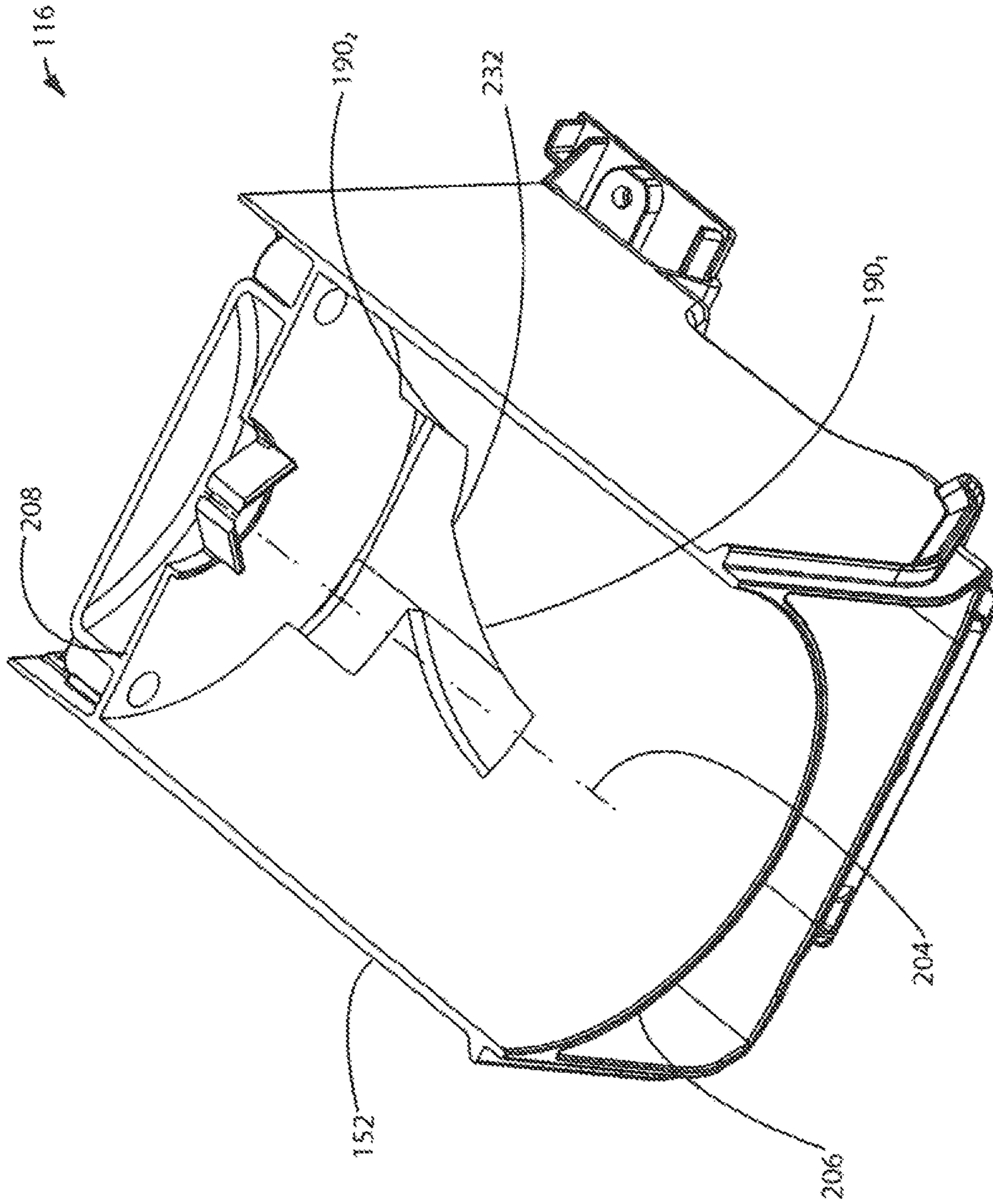


FIG. 15

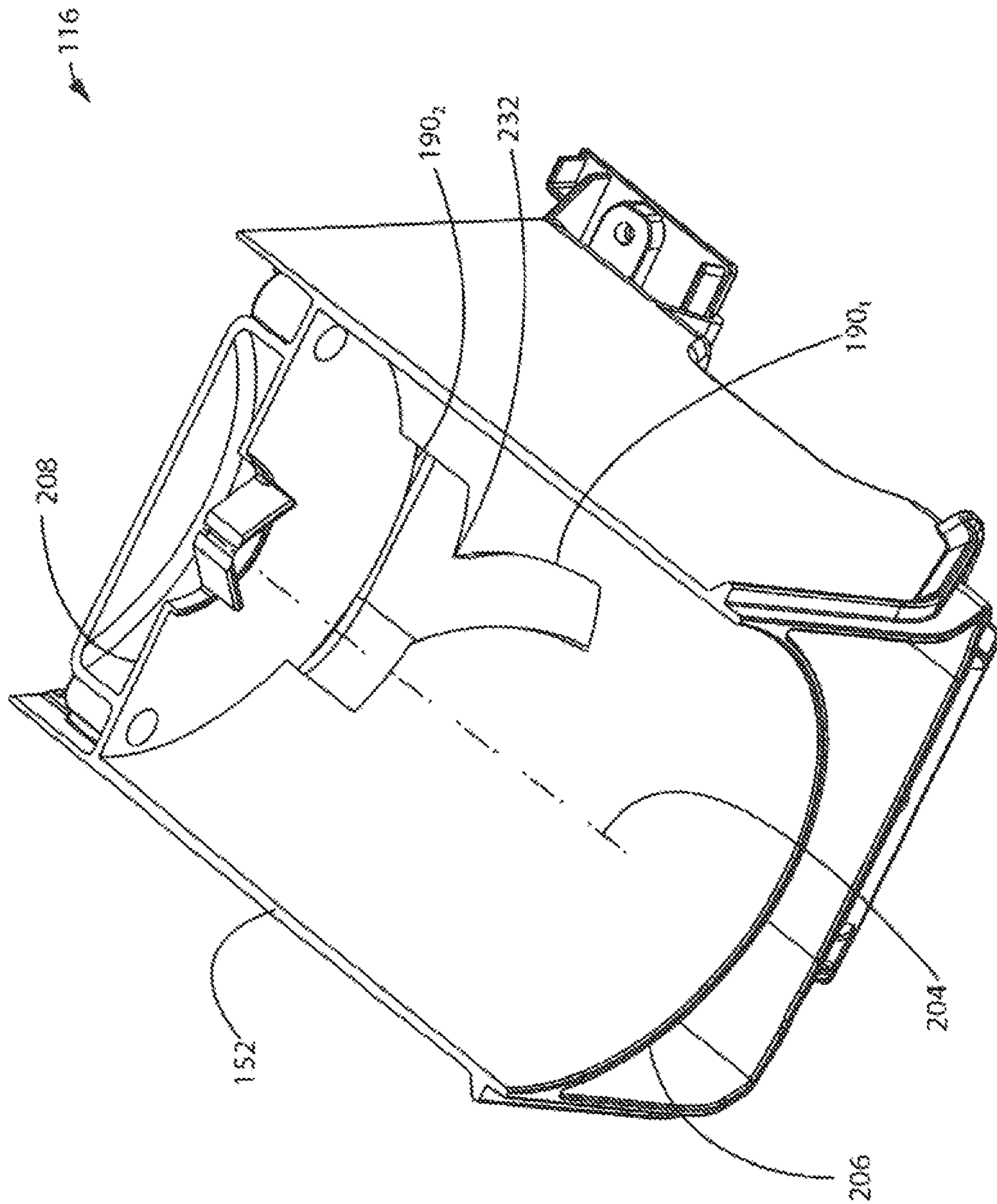


FIG. 16

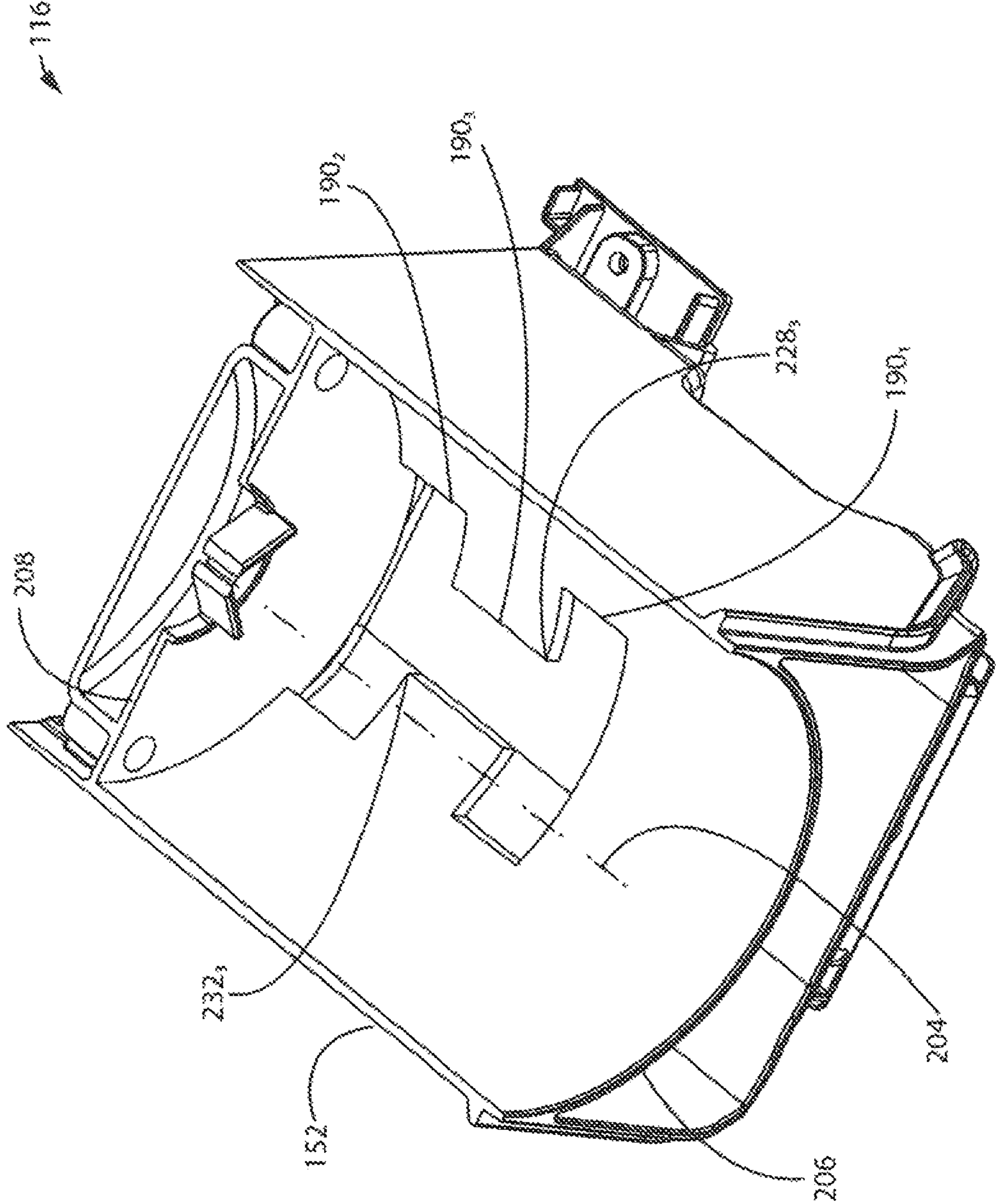


FIG. 17

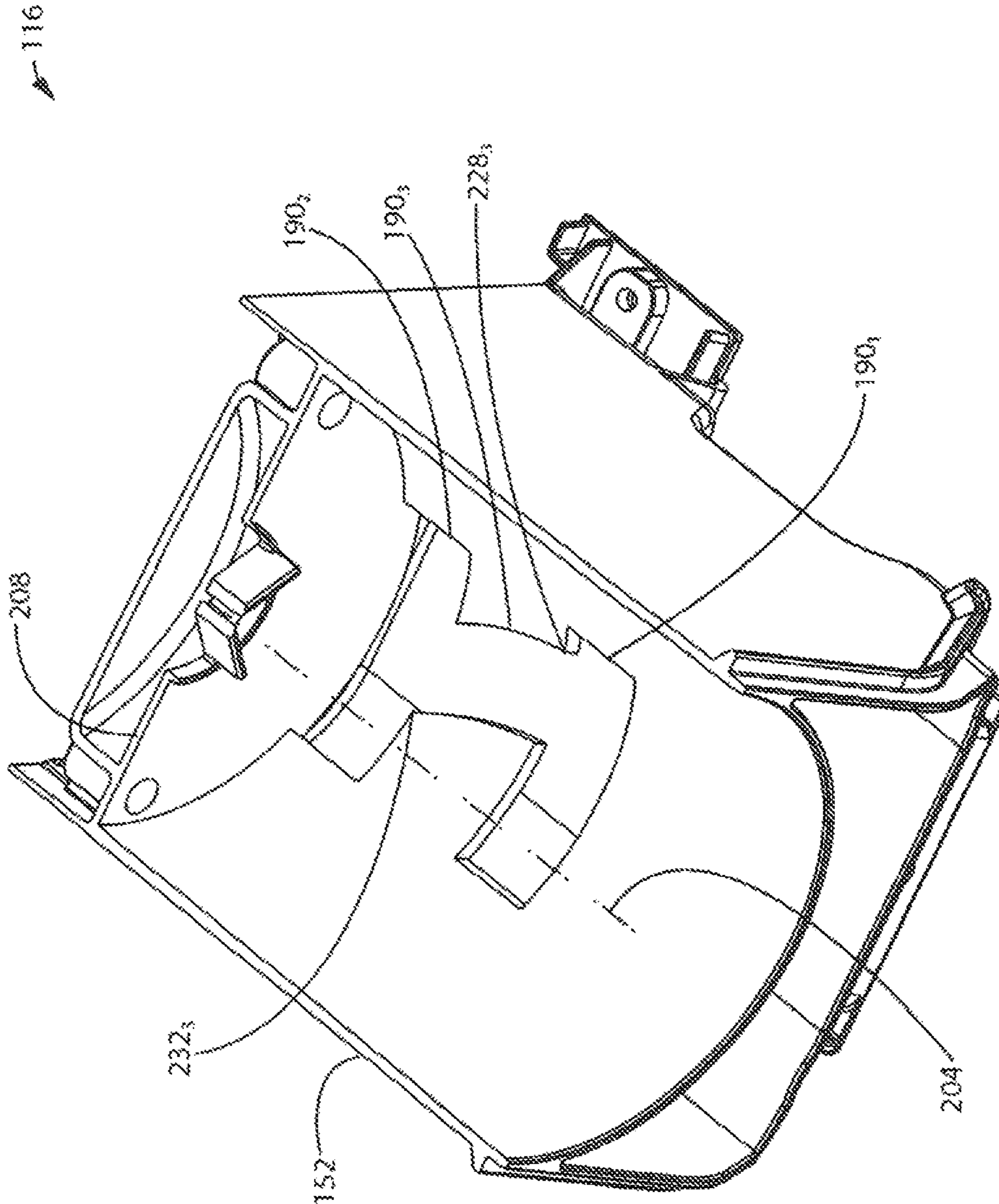


FIG. 18

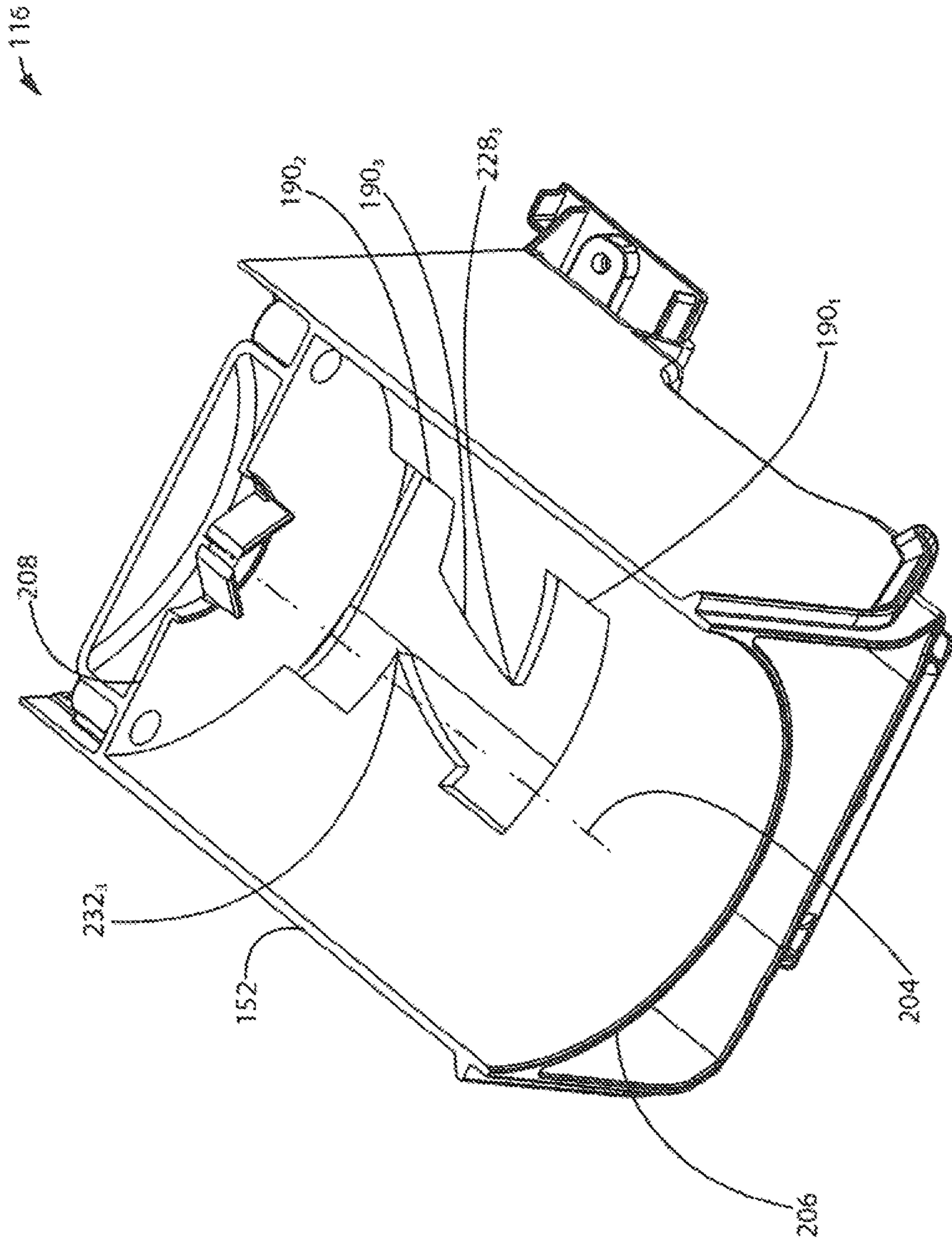


FIG. 19

116

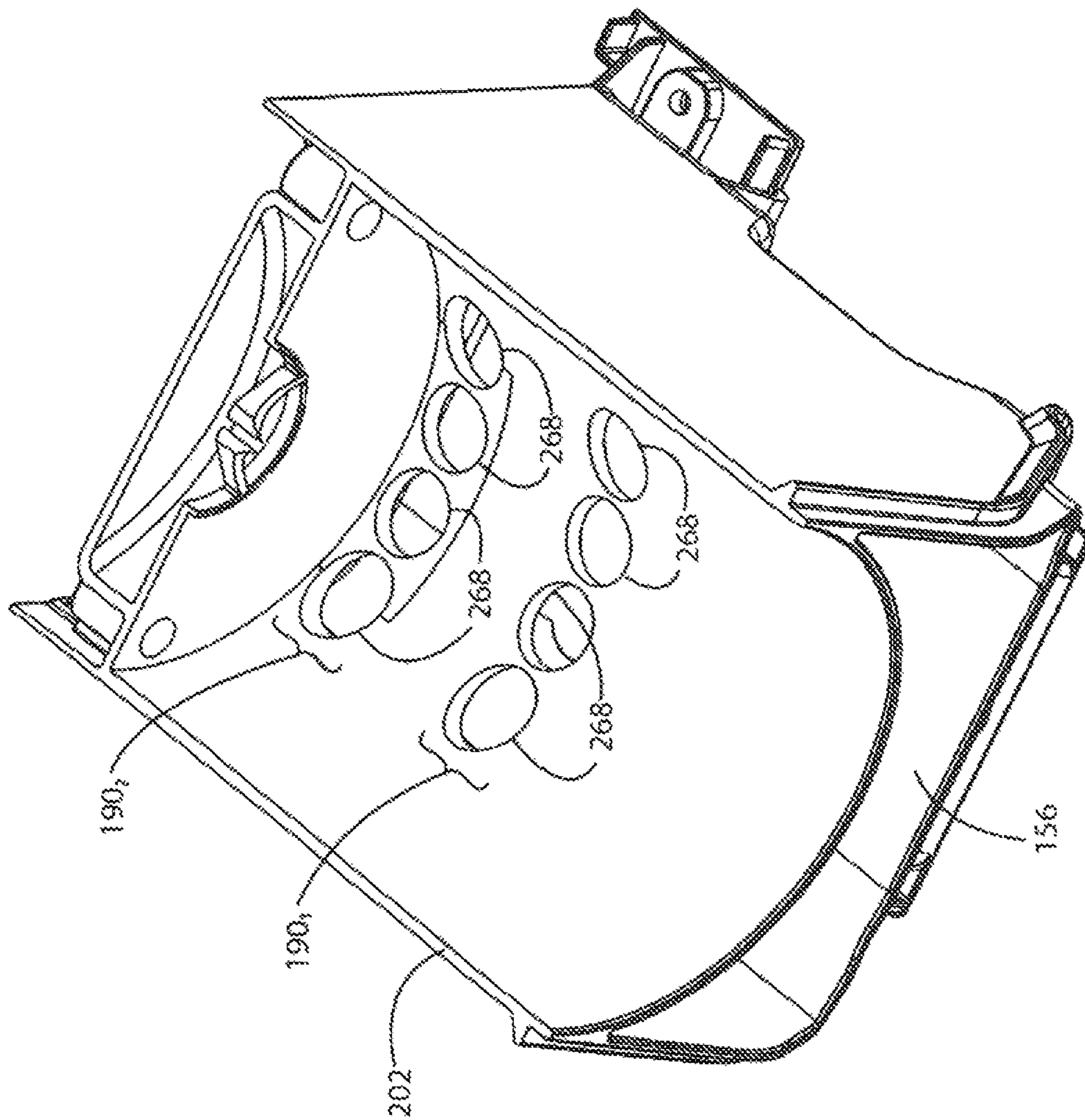
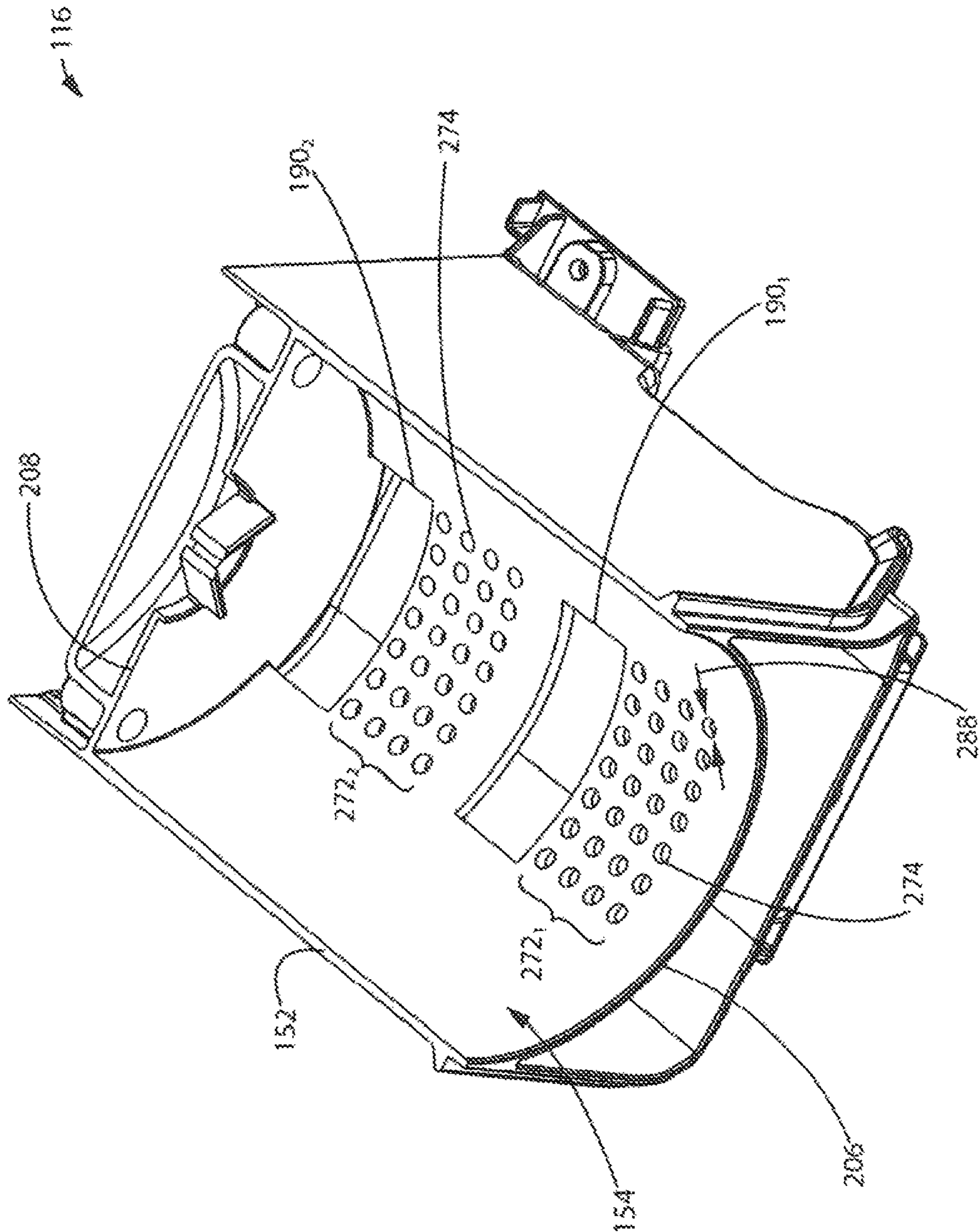


FIG. 20



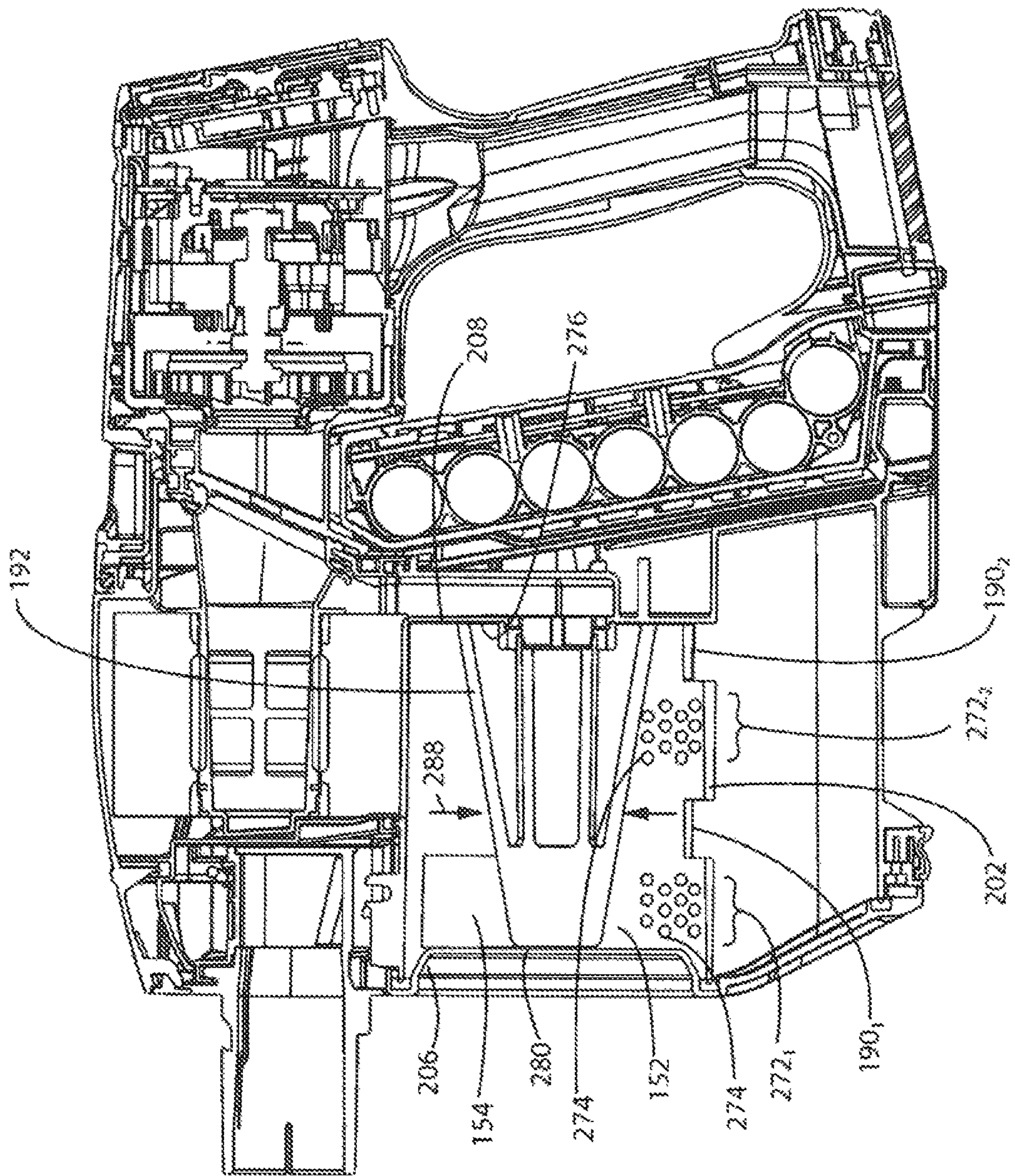


FIG. 22



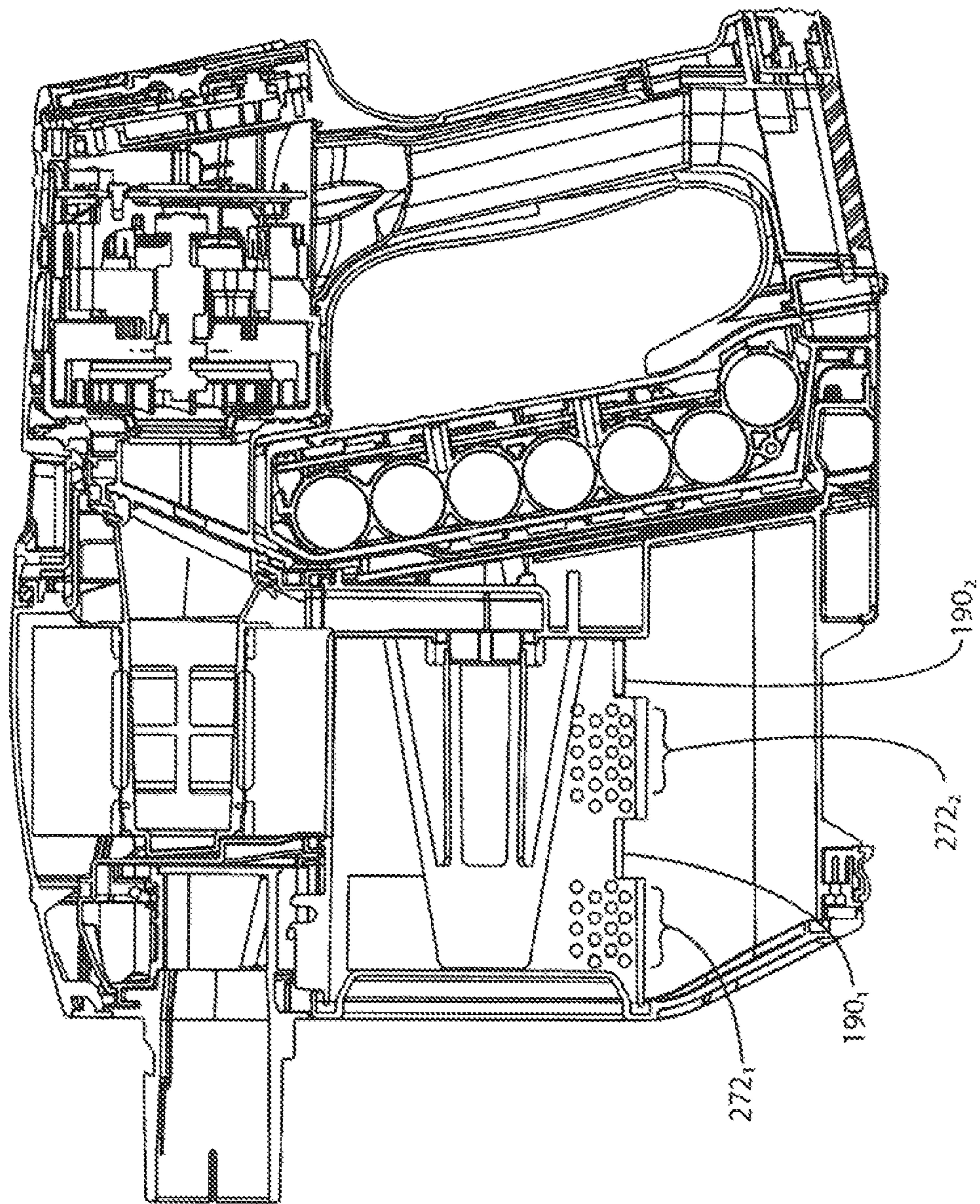


FIG. 23

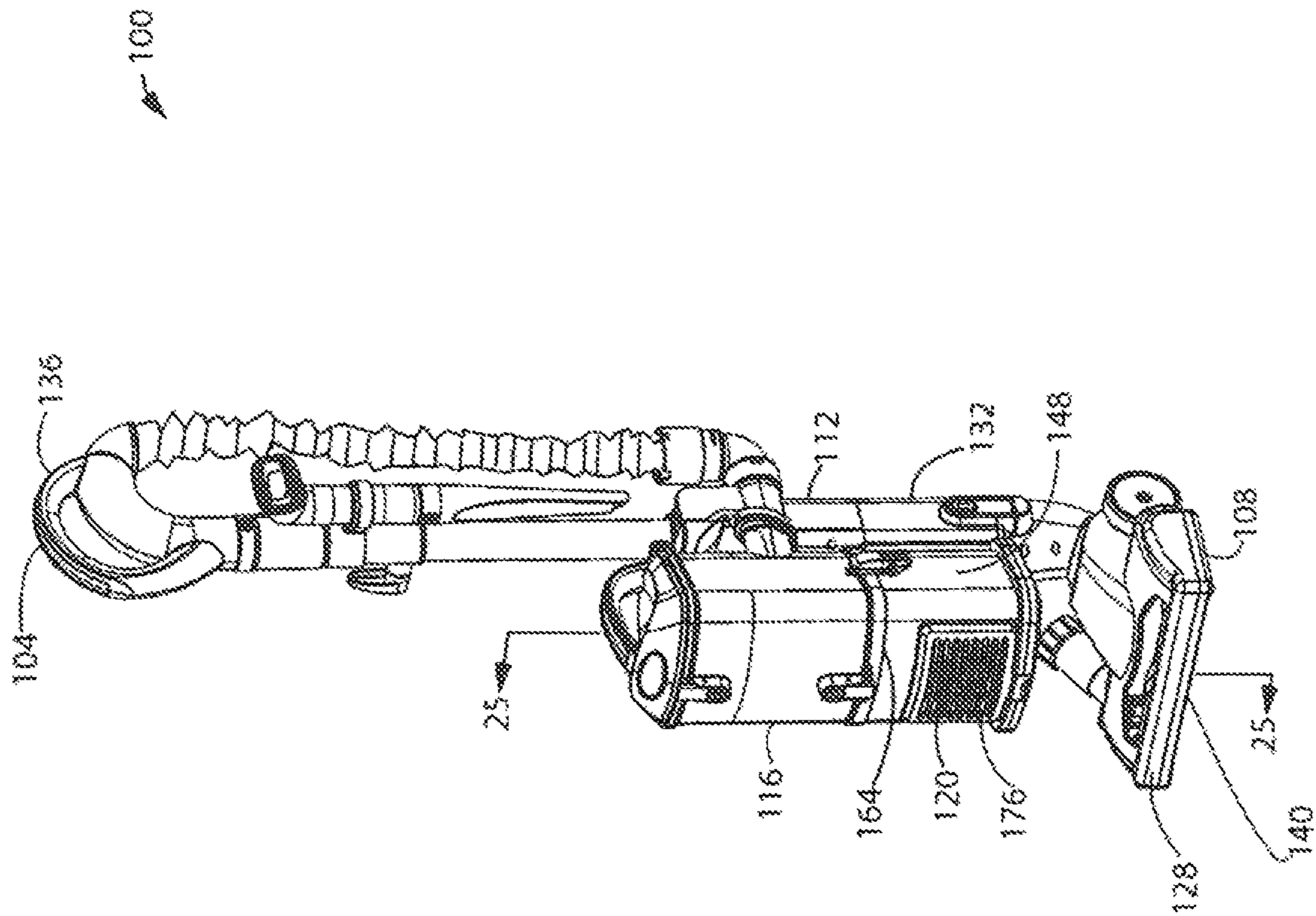


FIG. 24

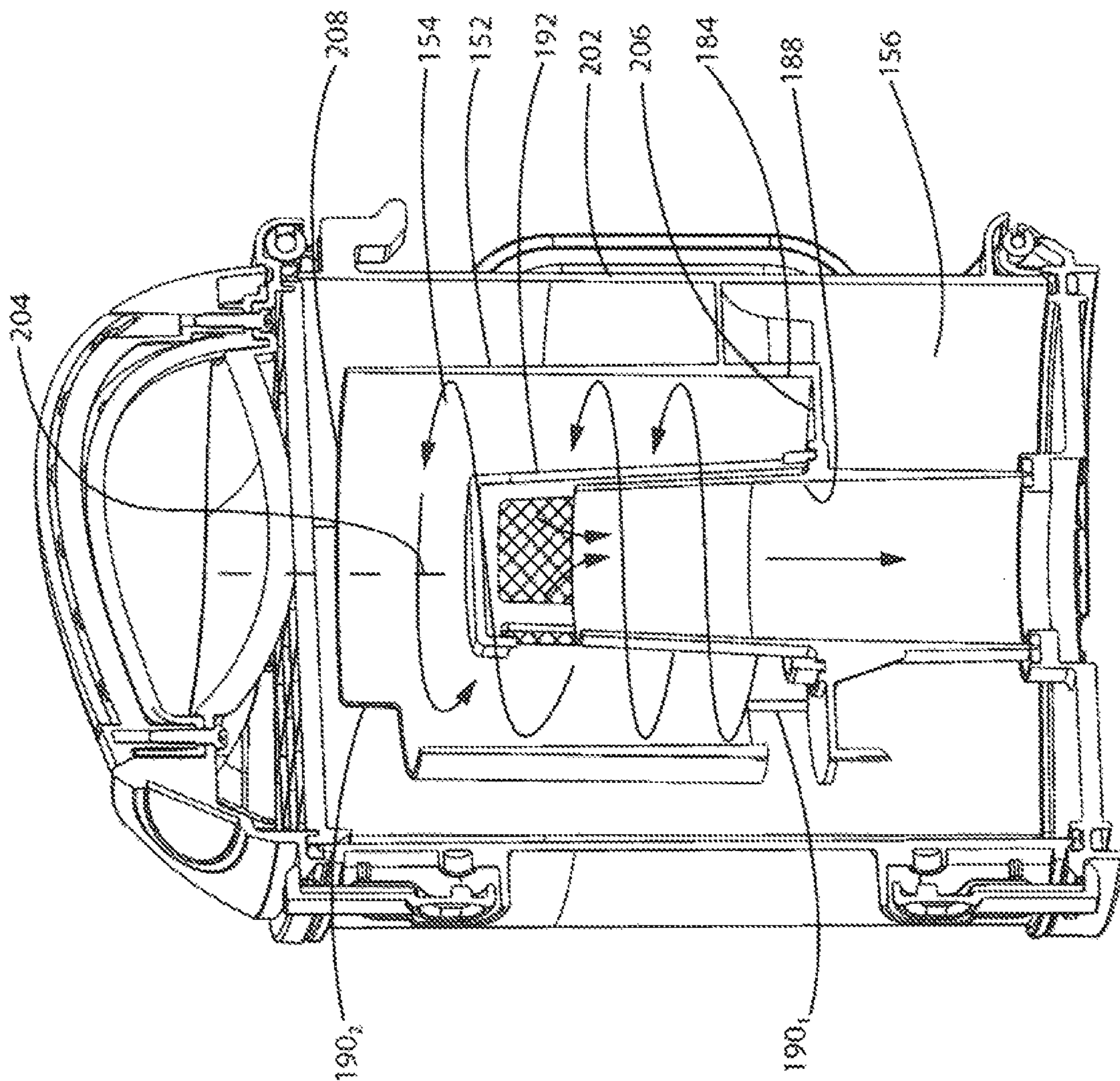
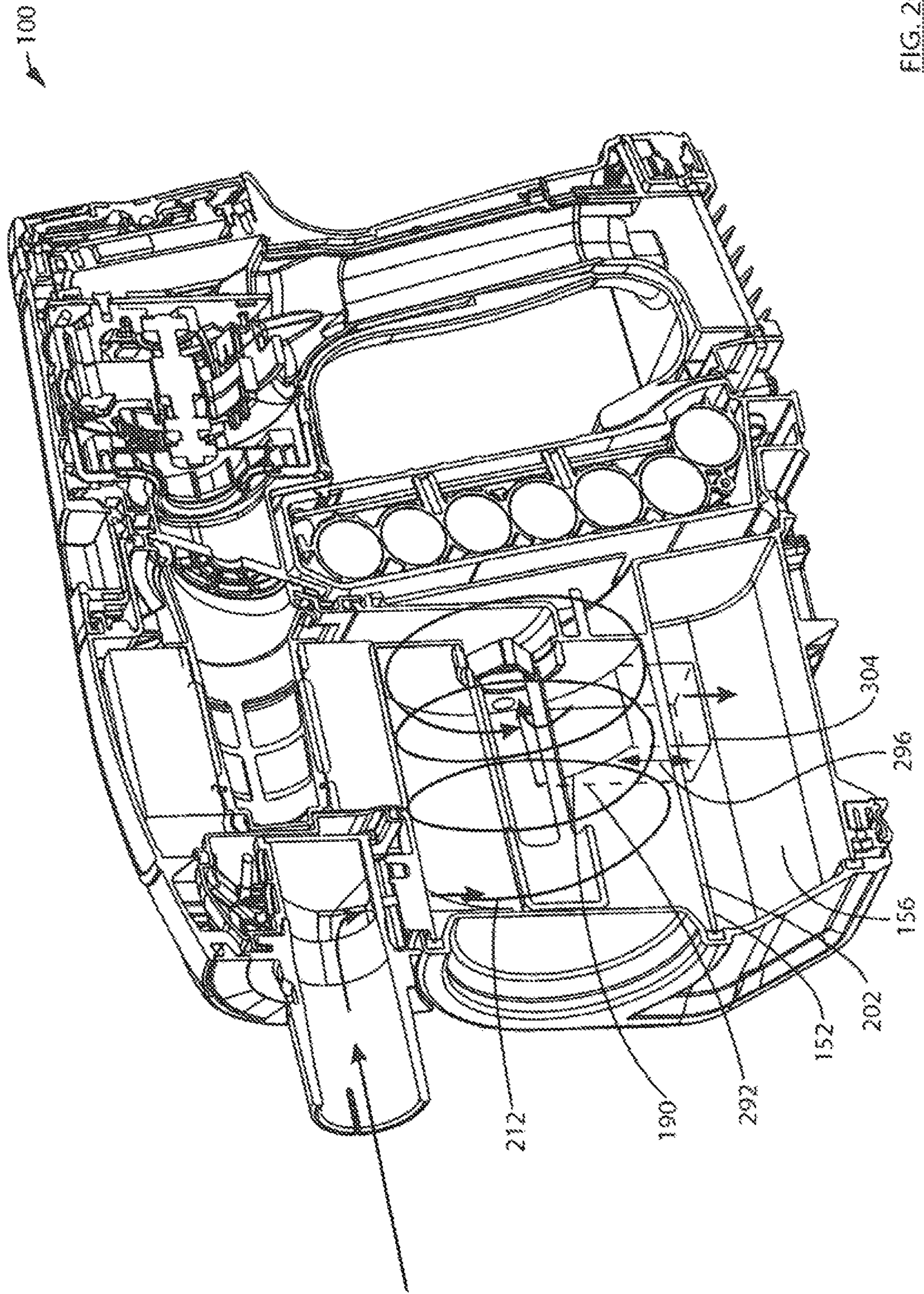


FIG. 25



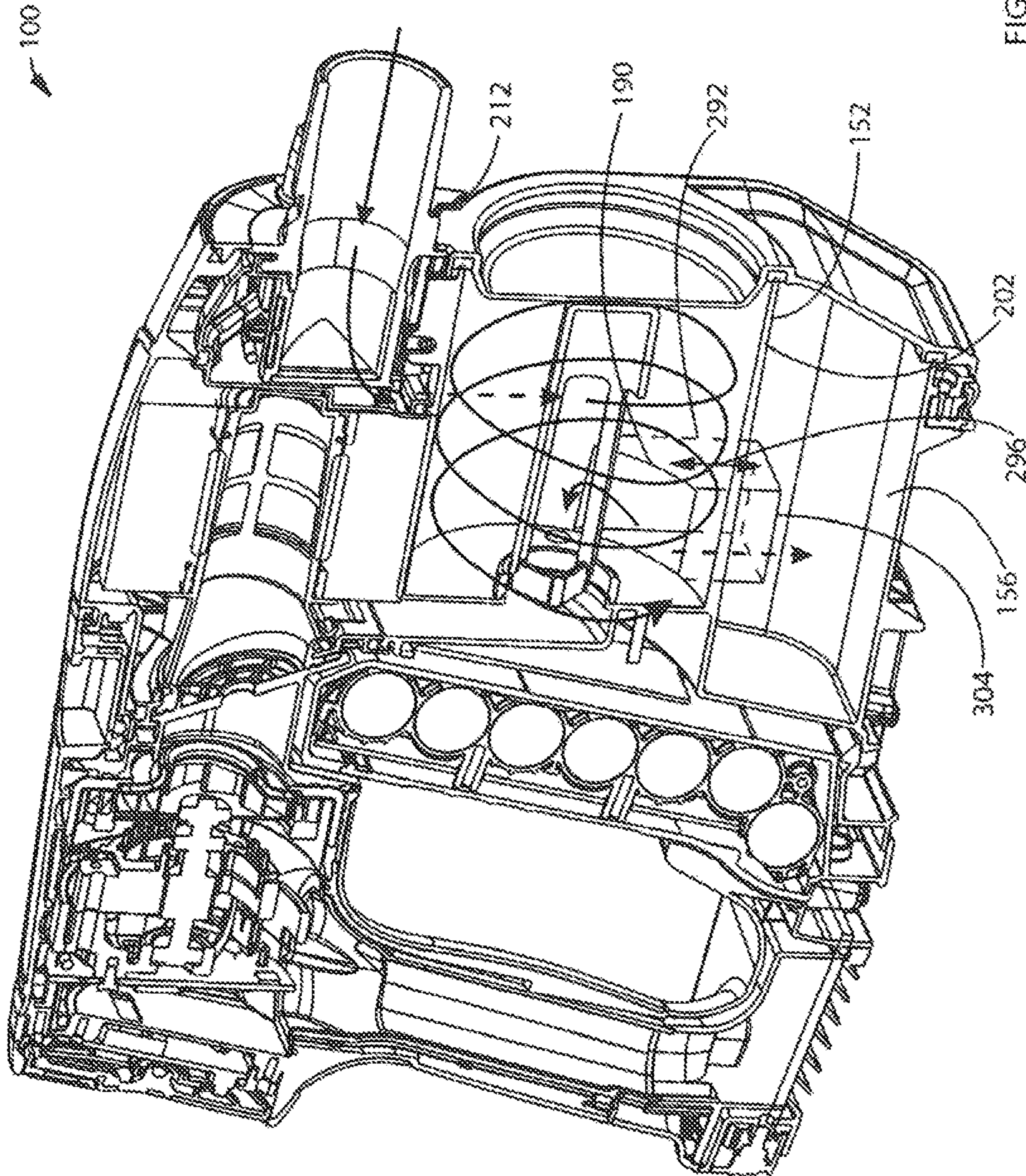


FIG. 27

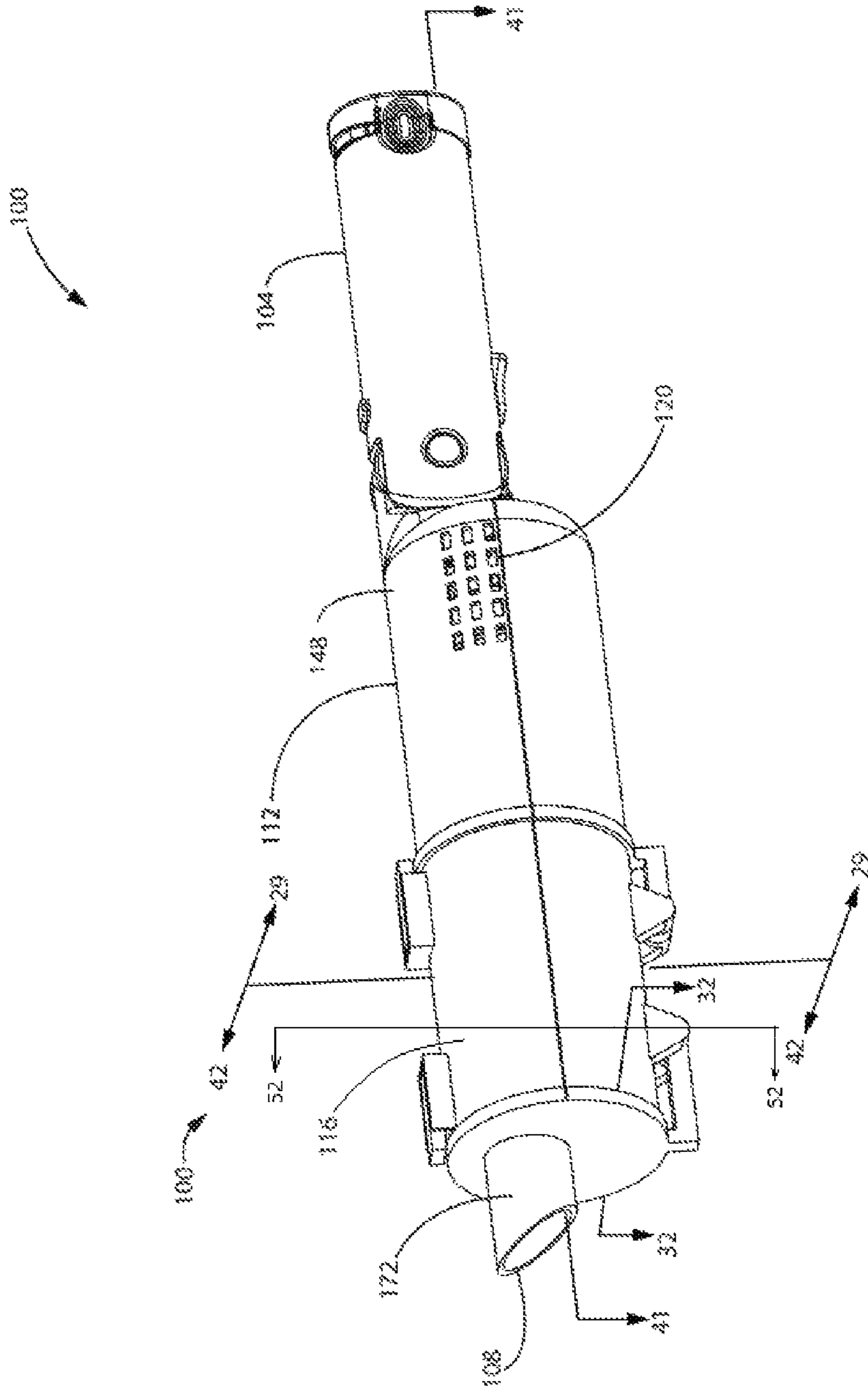


FIG. 28

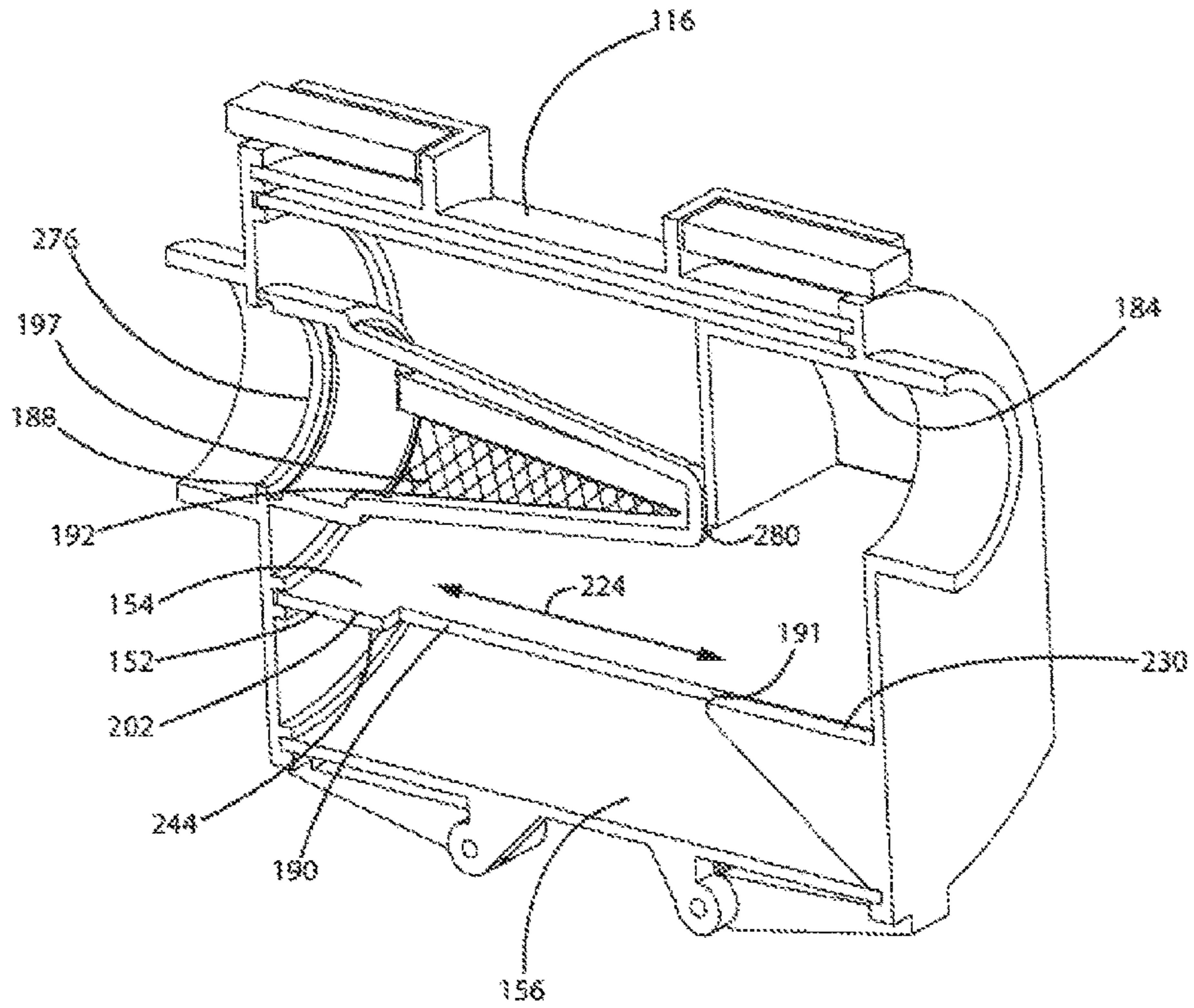


FIG. 29

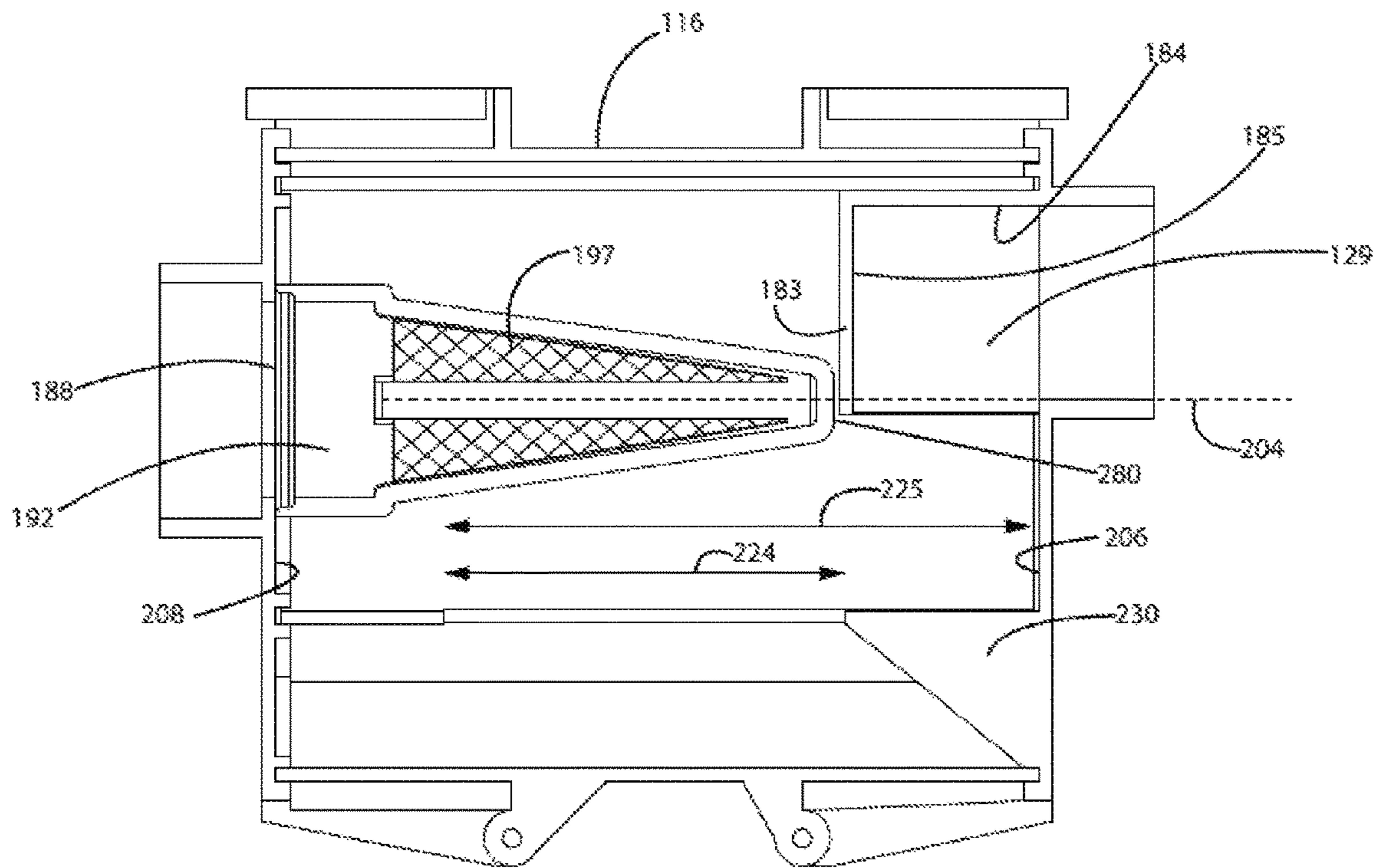


FIG. 30

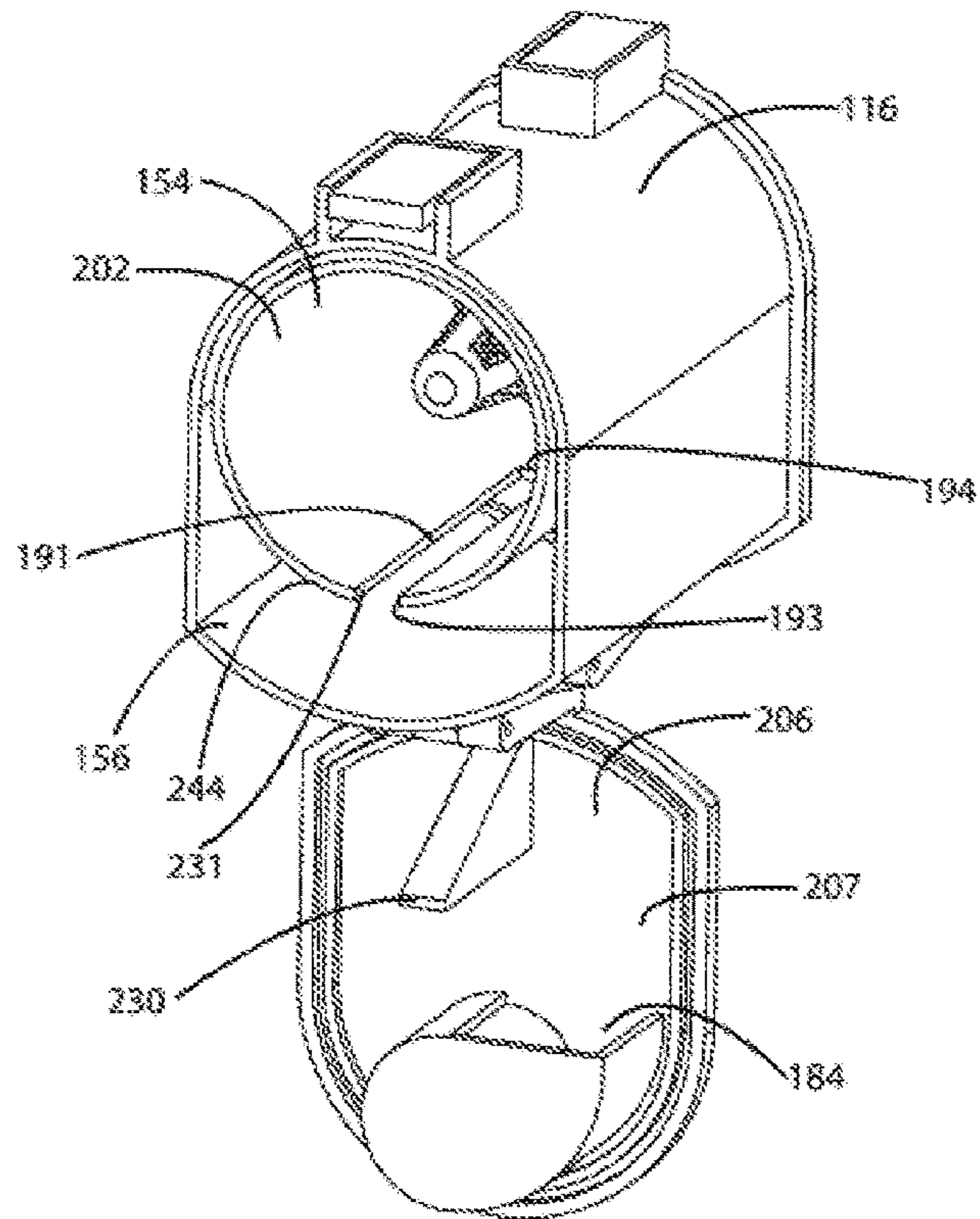


FIG. 31

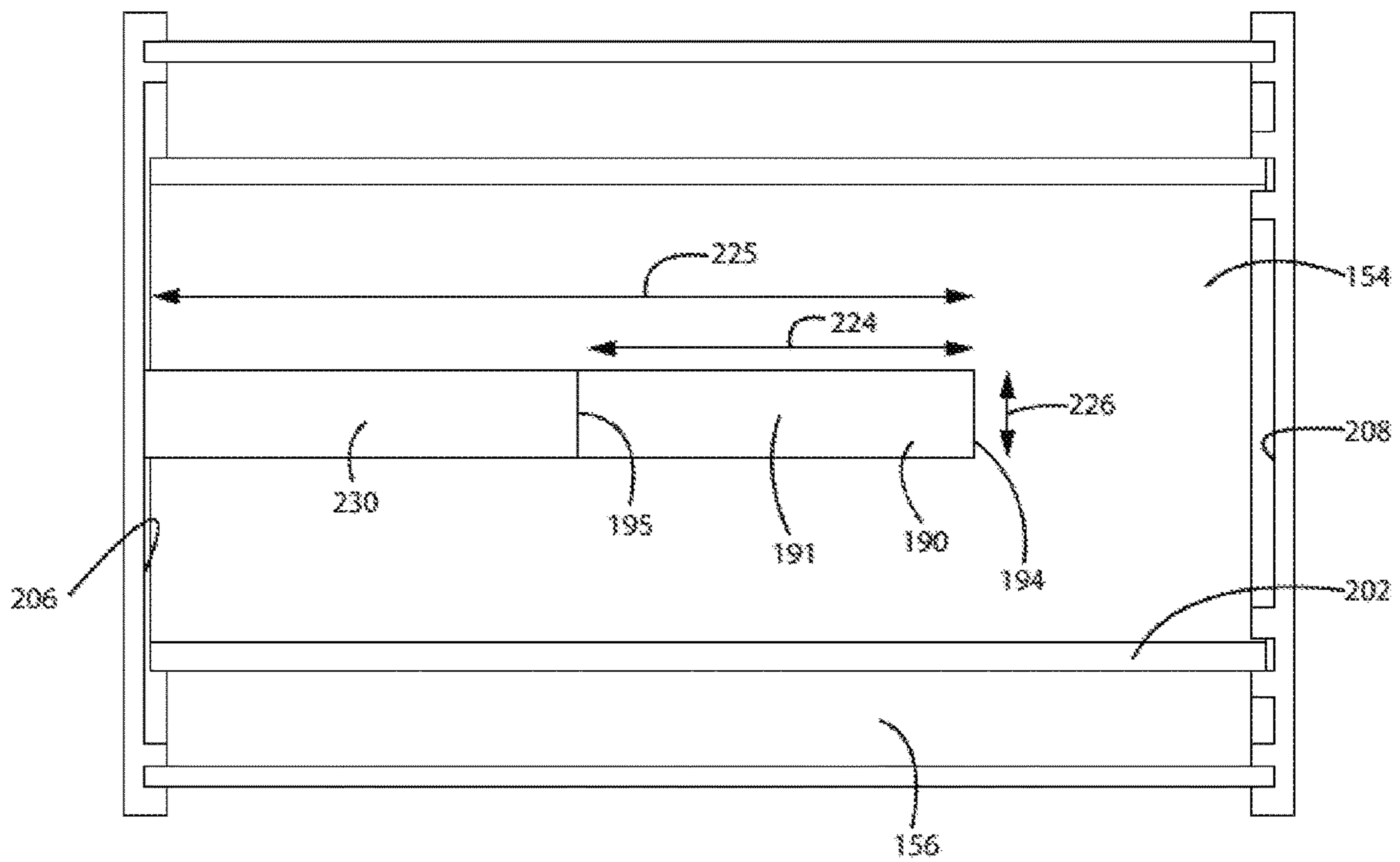


FIG. 32



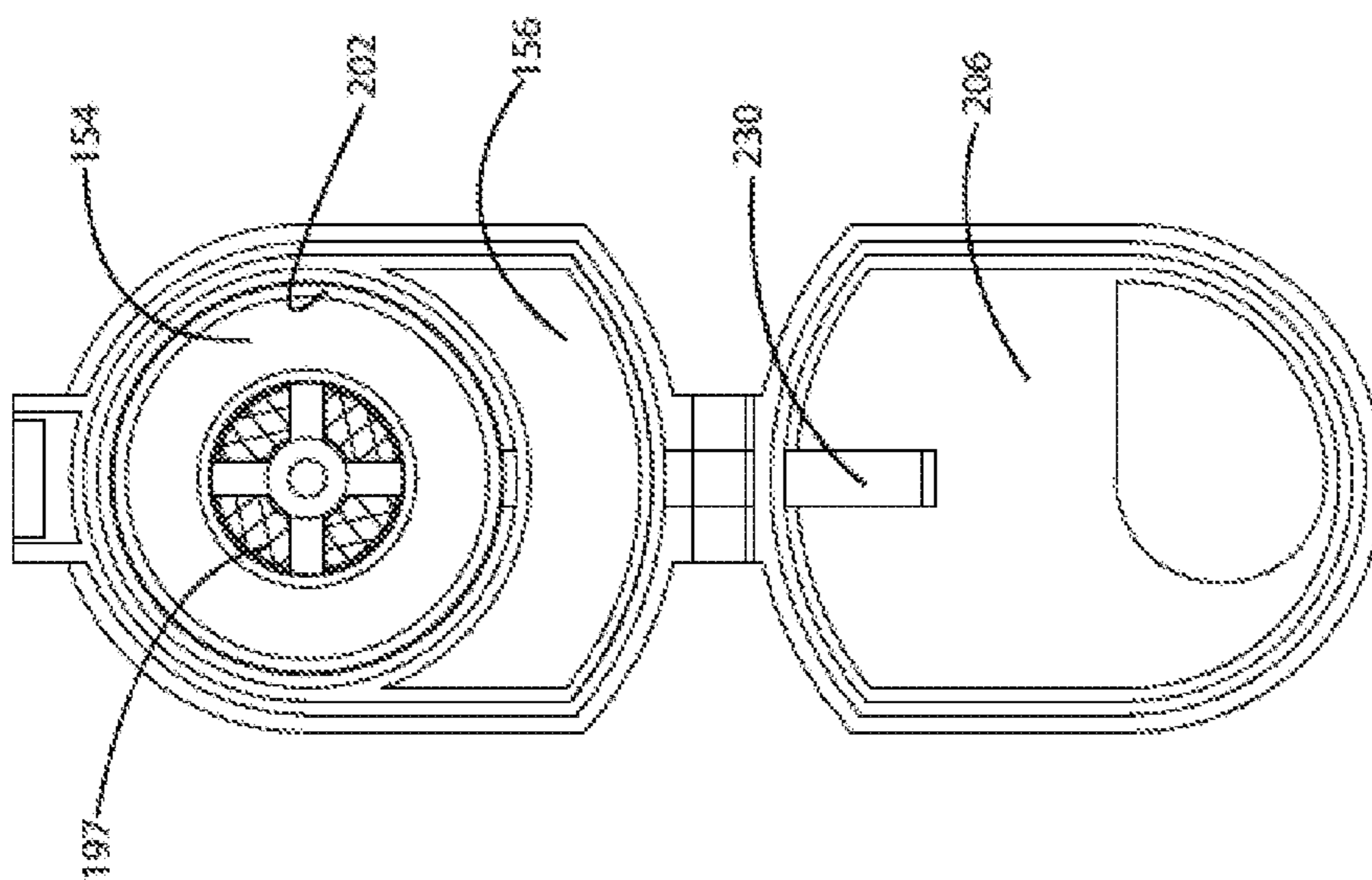


FIG. 33

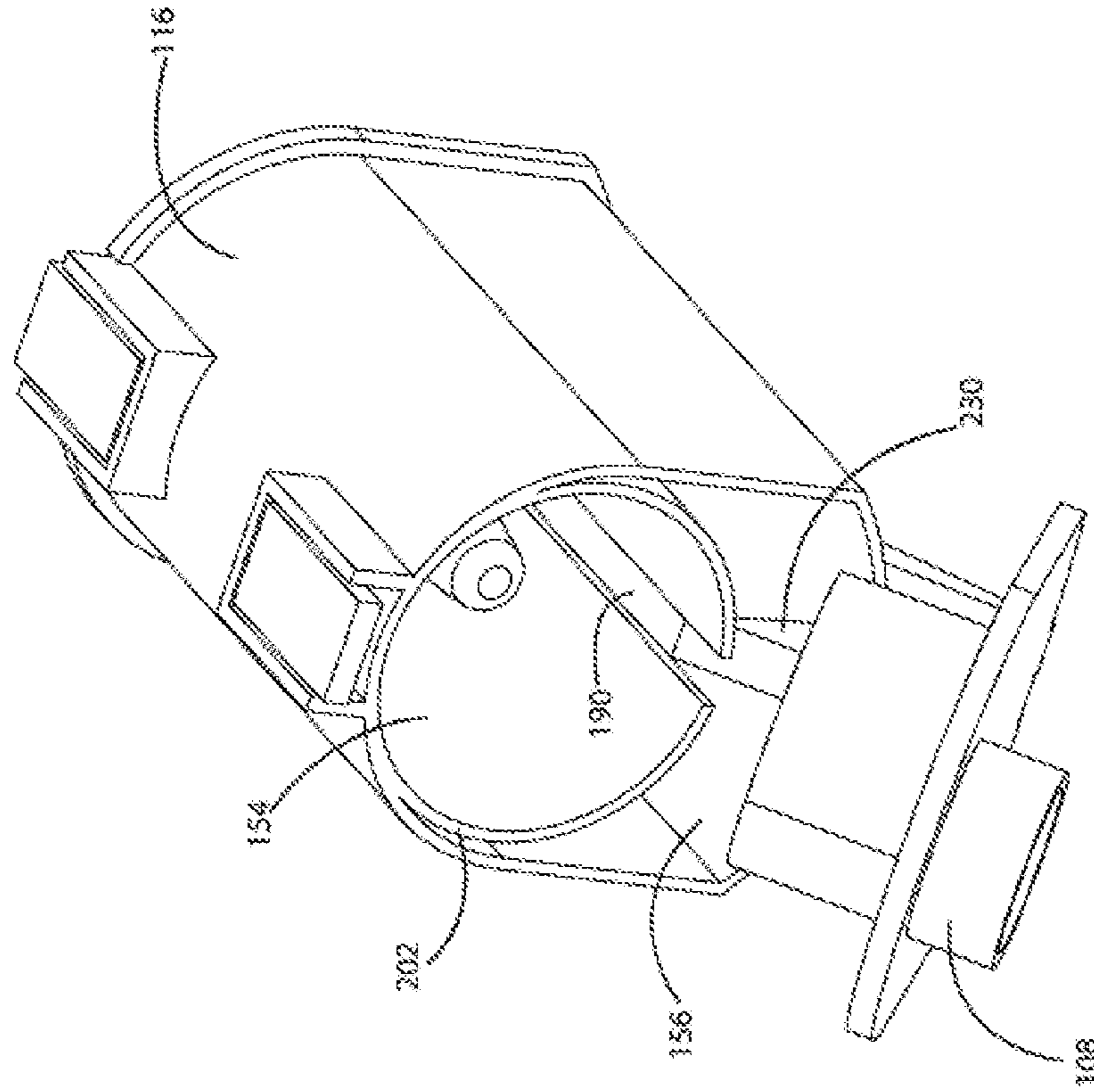


FIG. 34

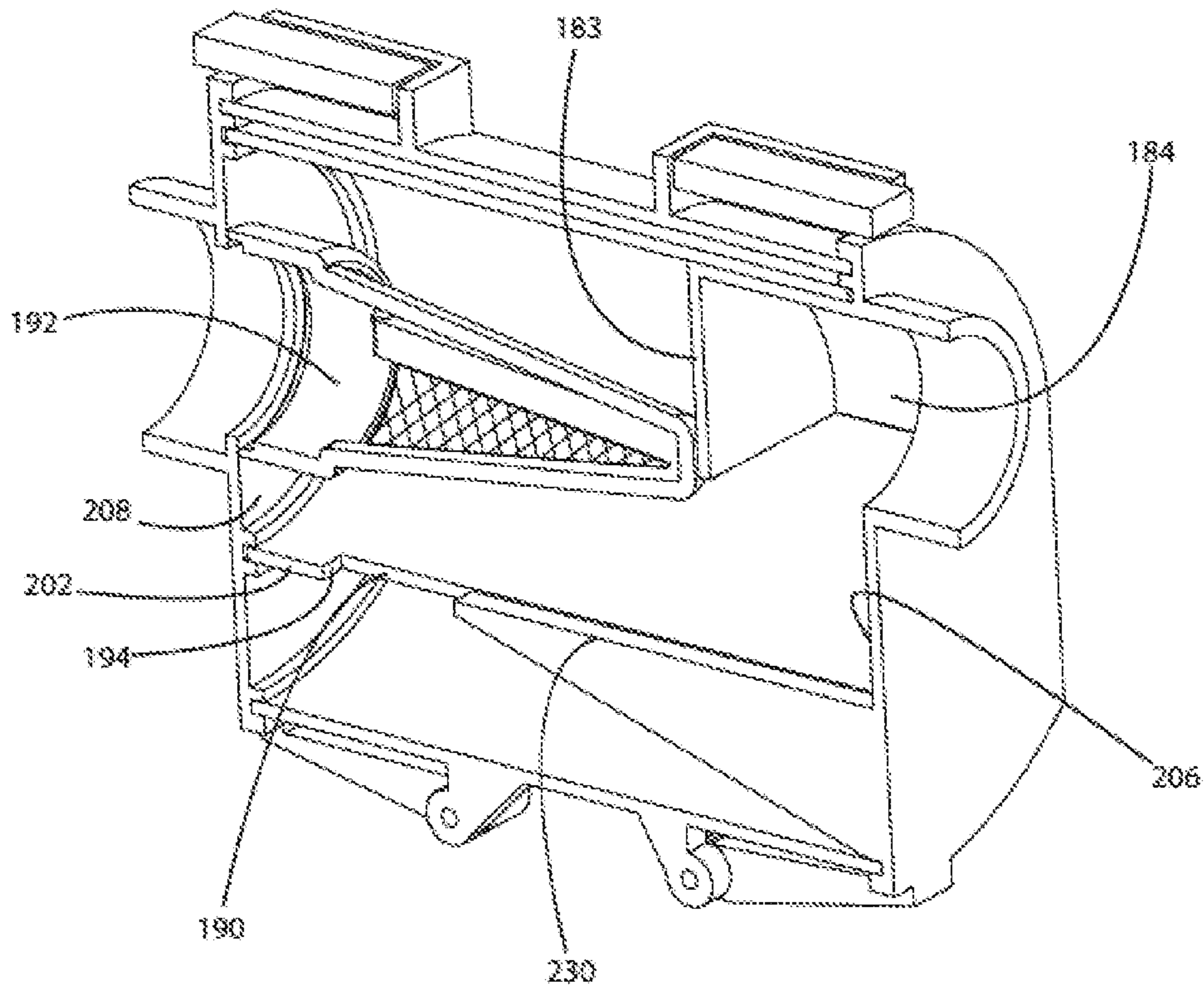


FIG. 35

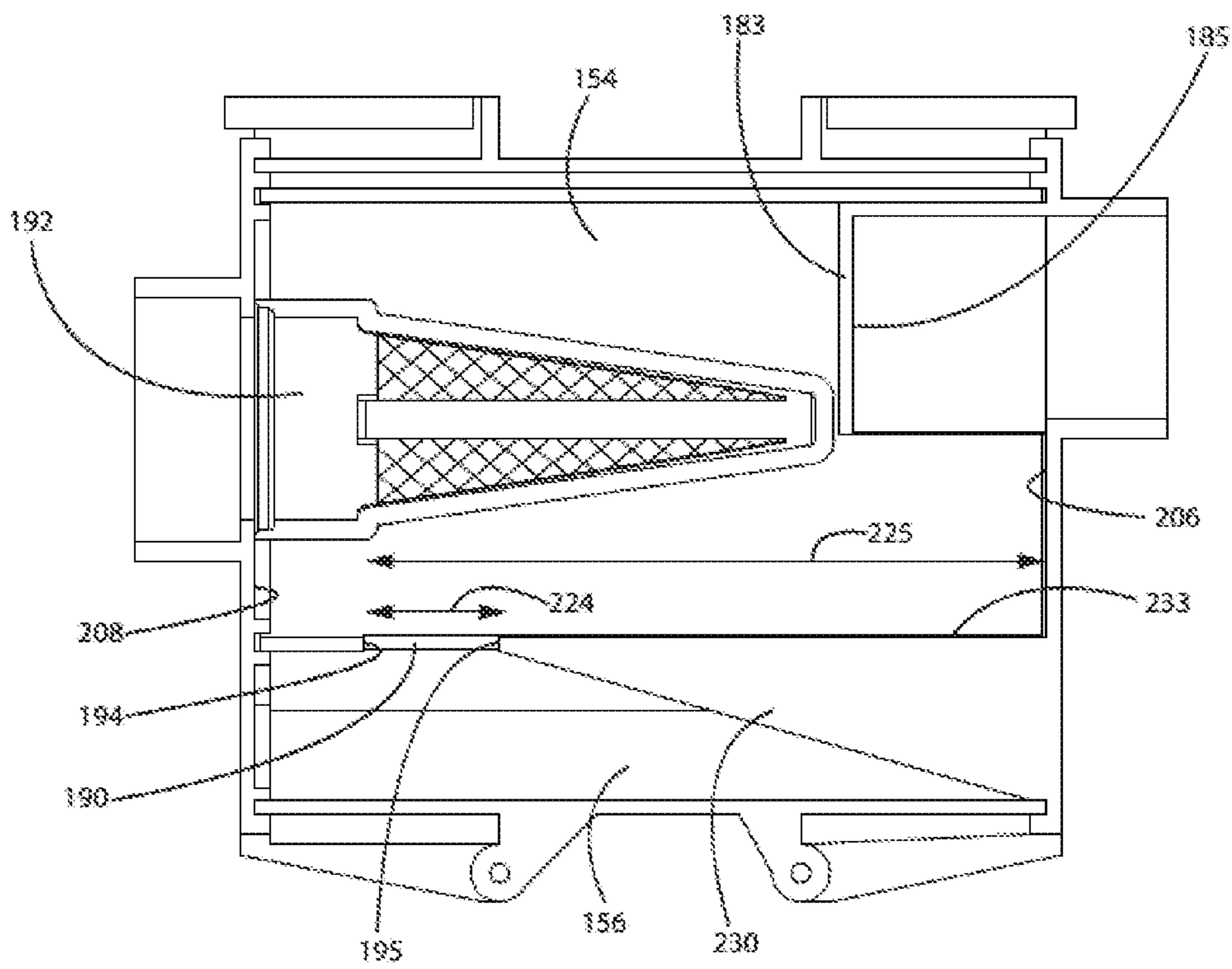


FIG. 36

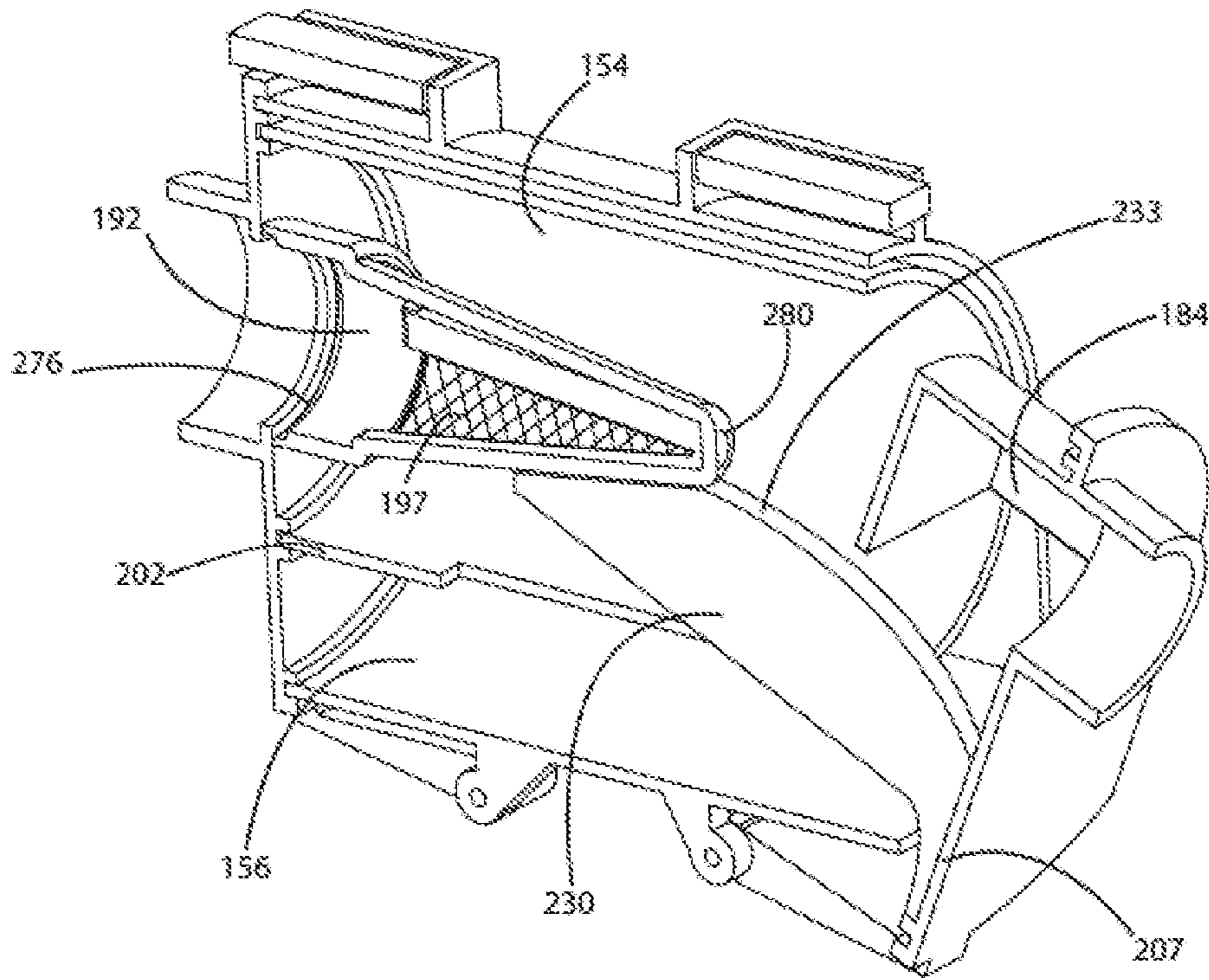


FIG. 37

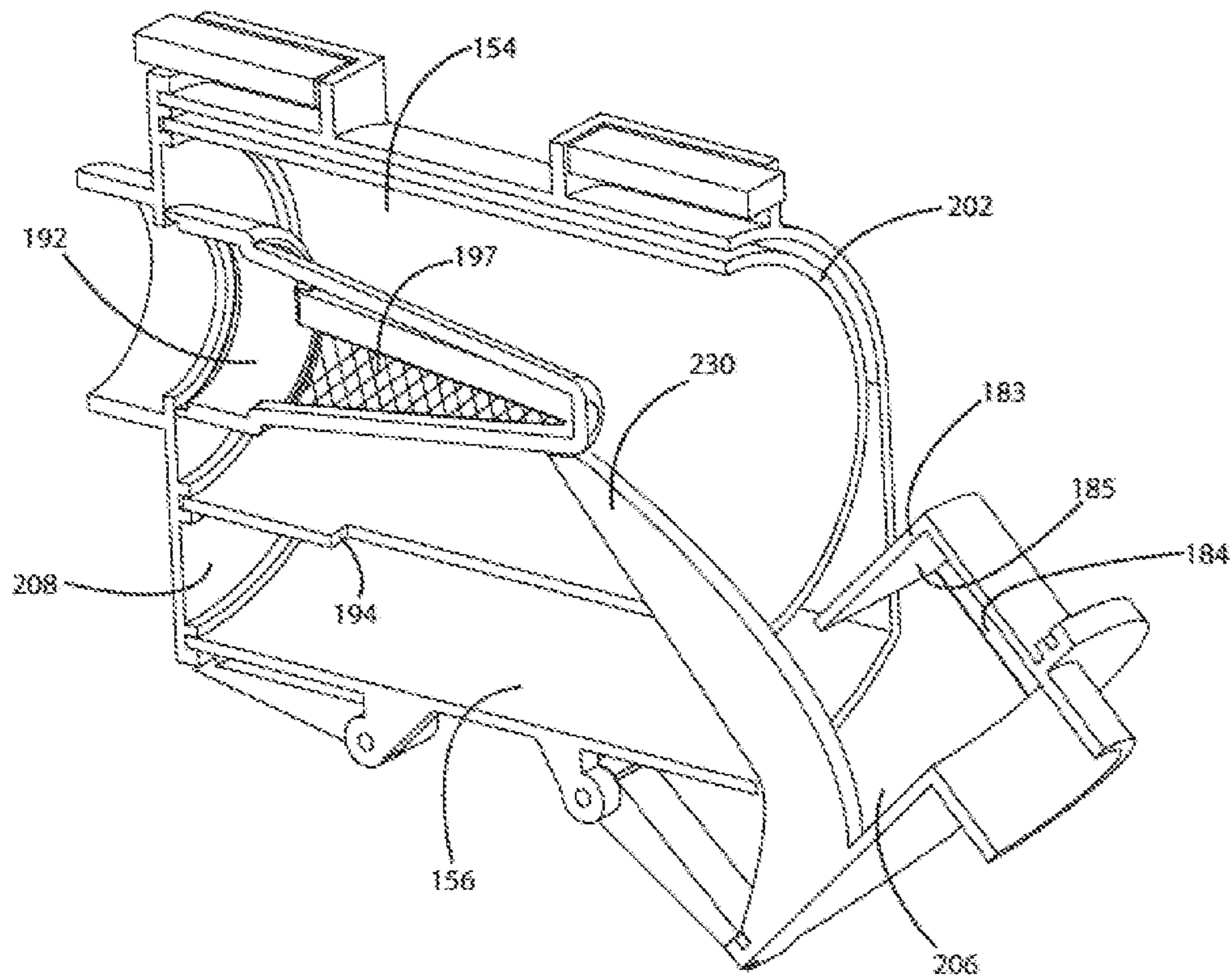


FIG. 38

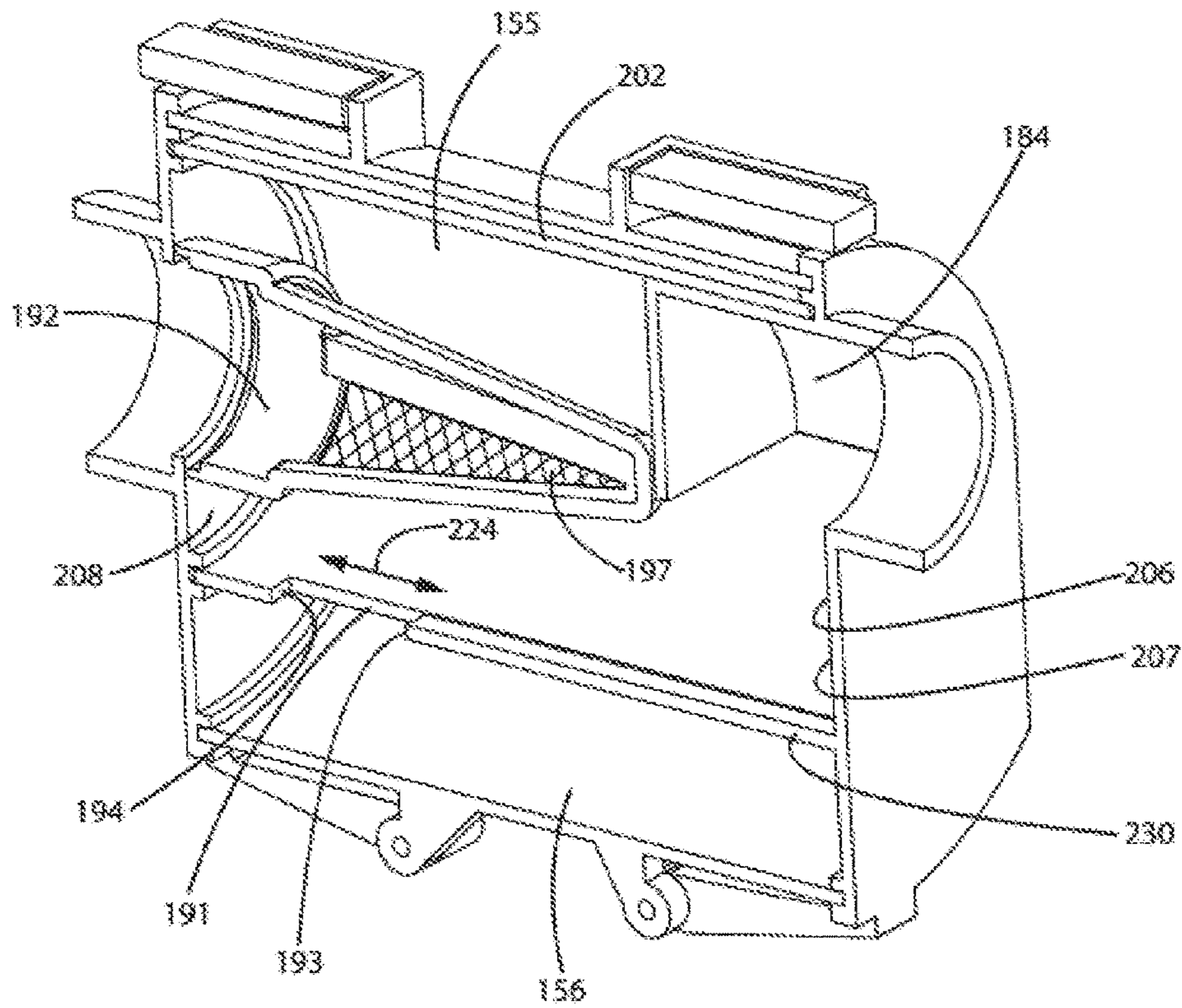


FIG. 39

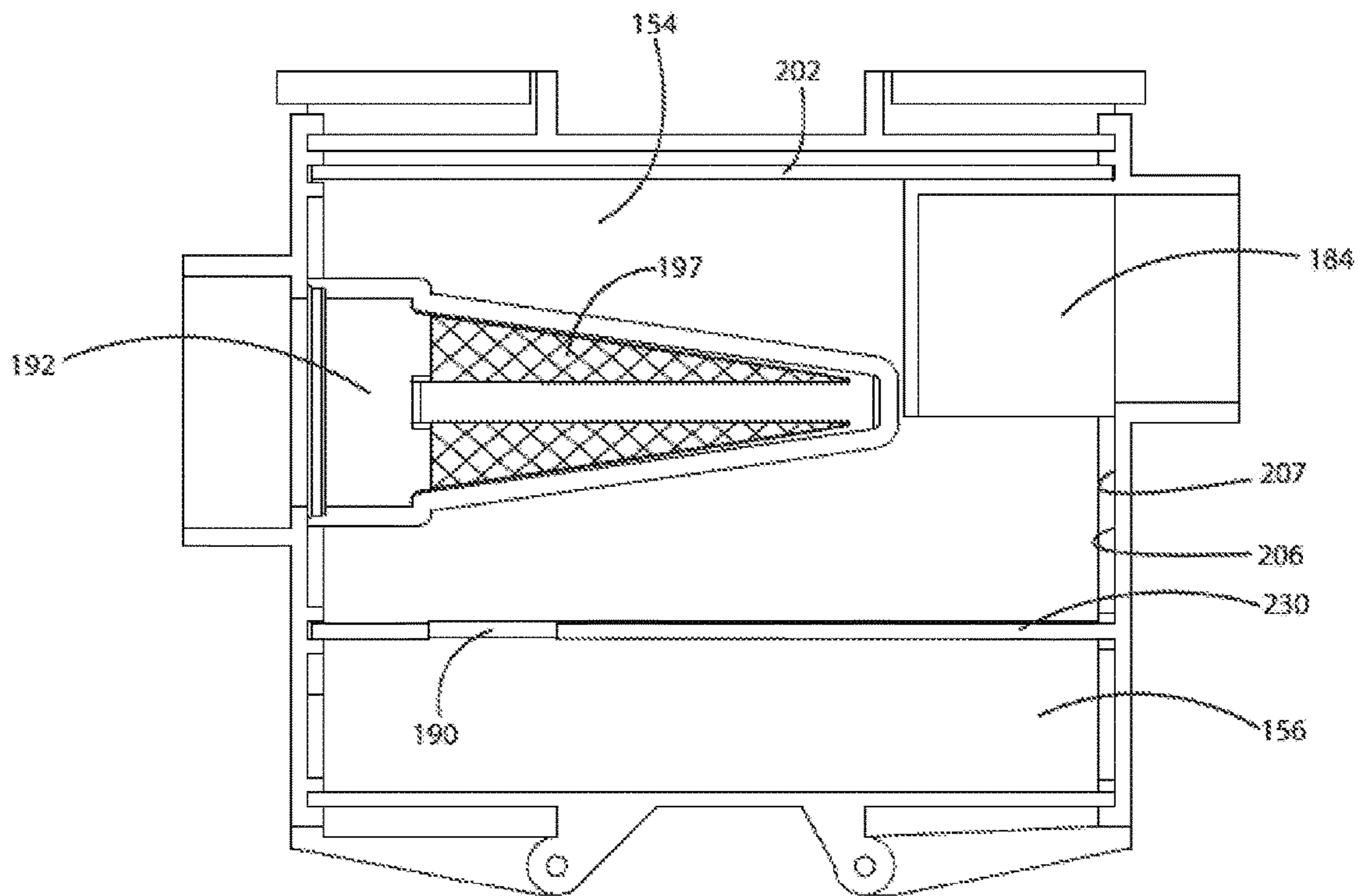


FIG. 40

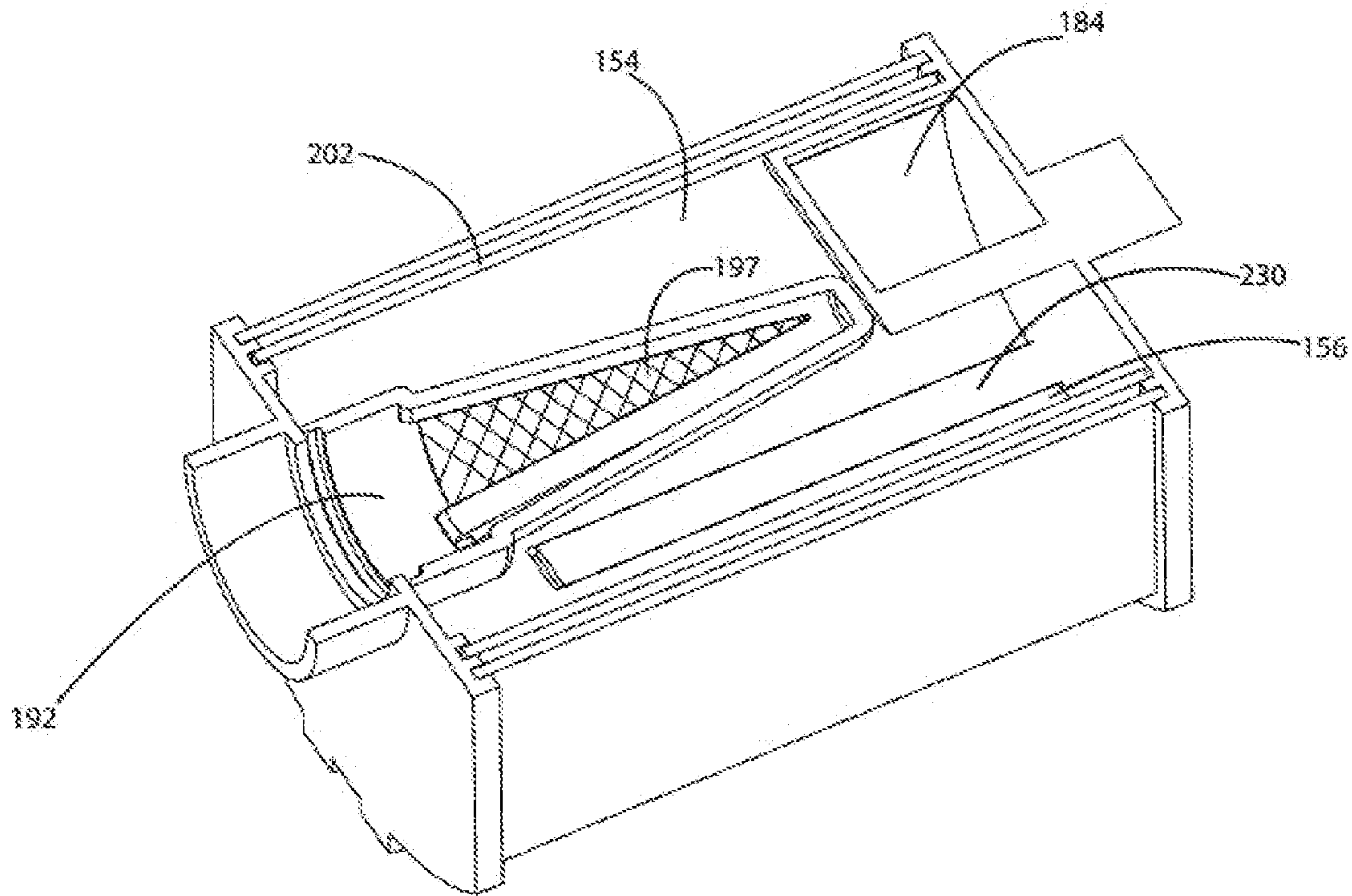


FIG. 41

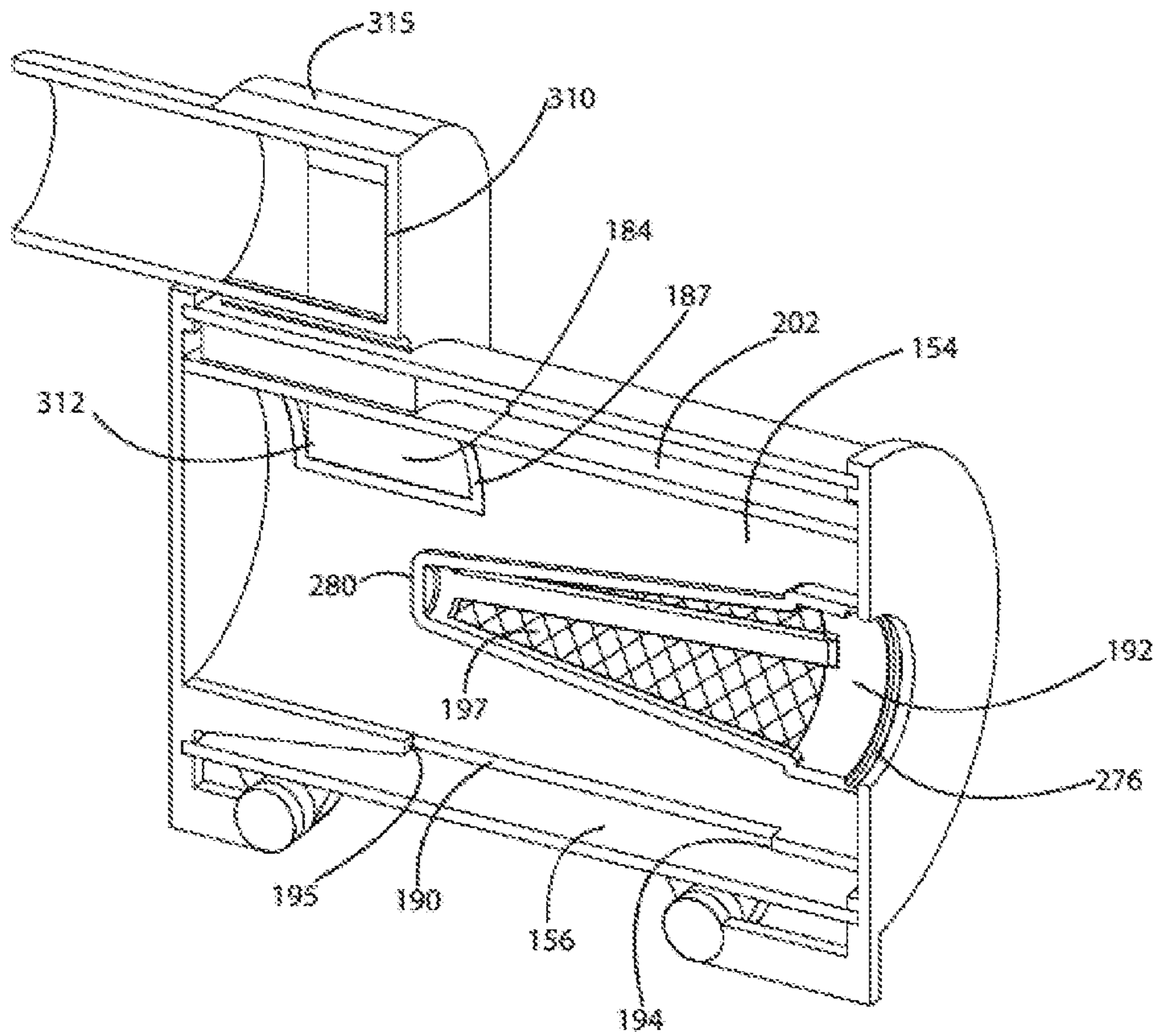


FIG. 42

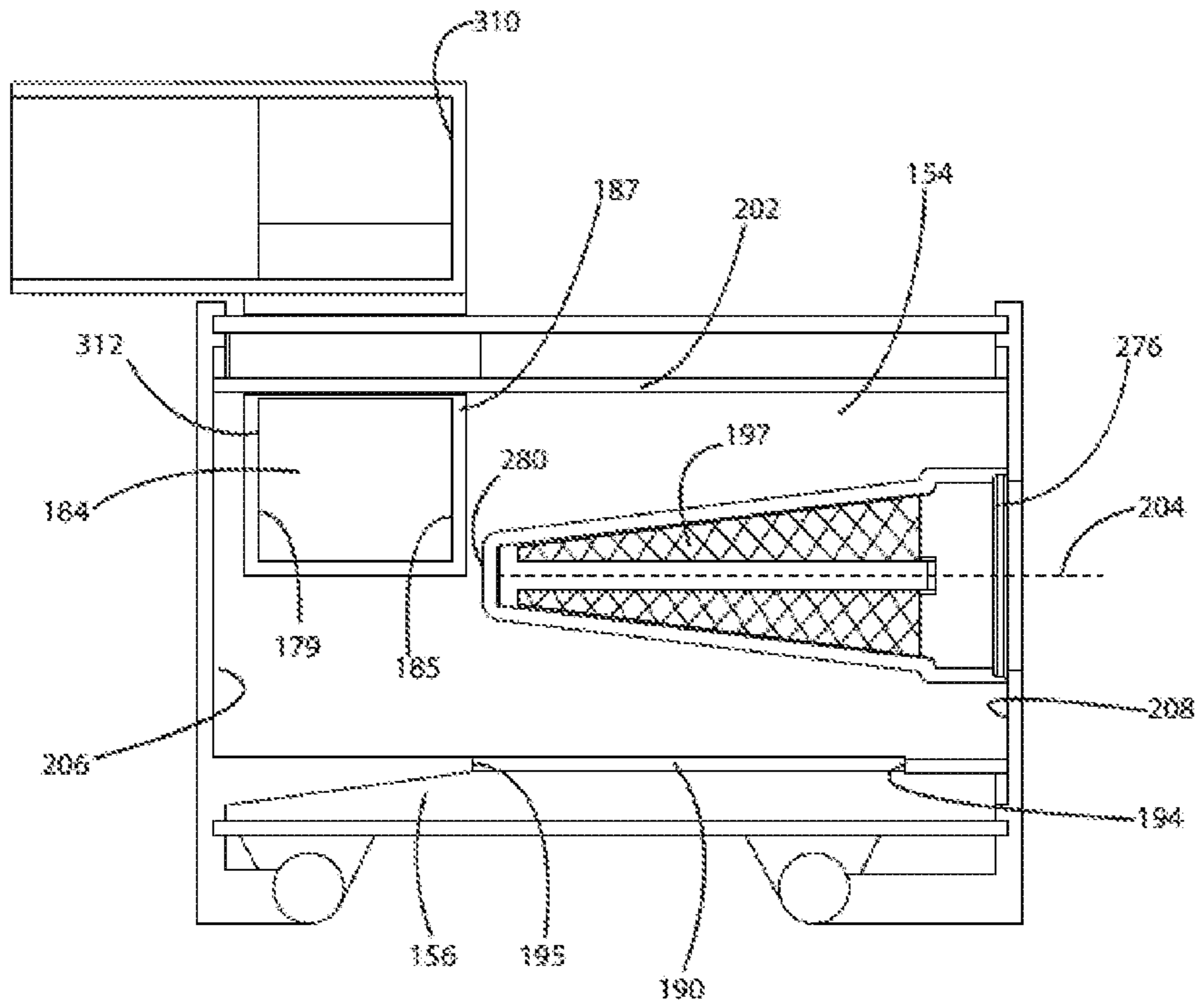


FIG. 43

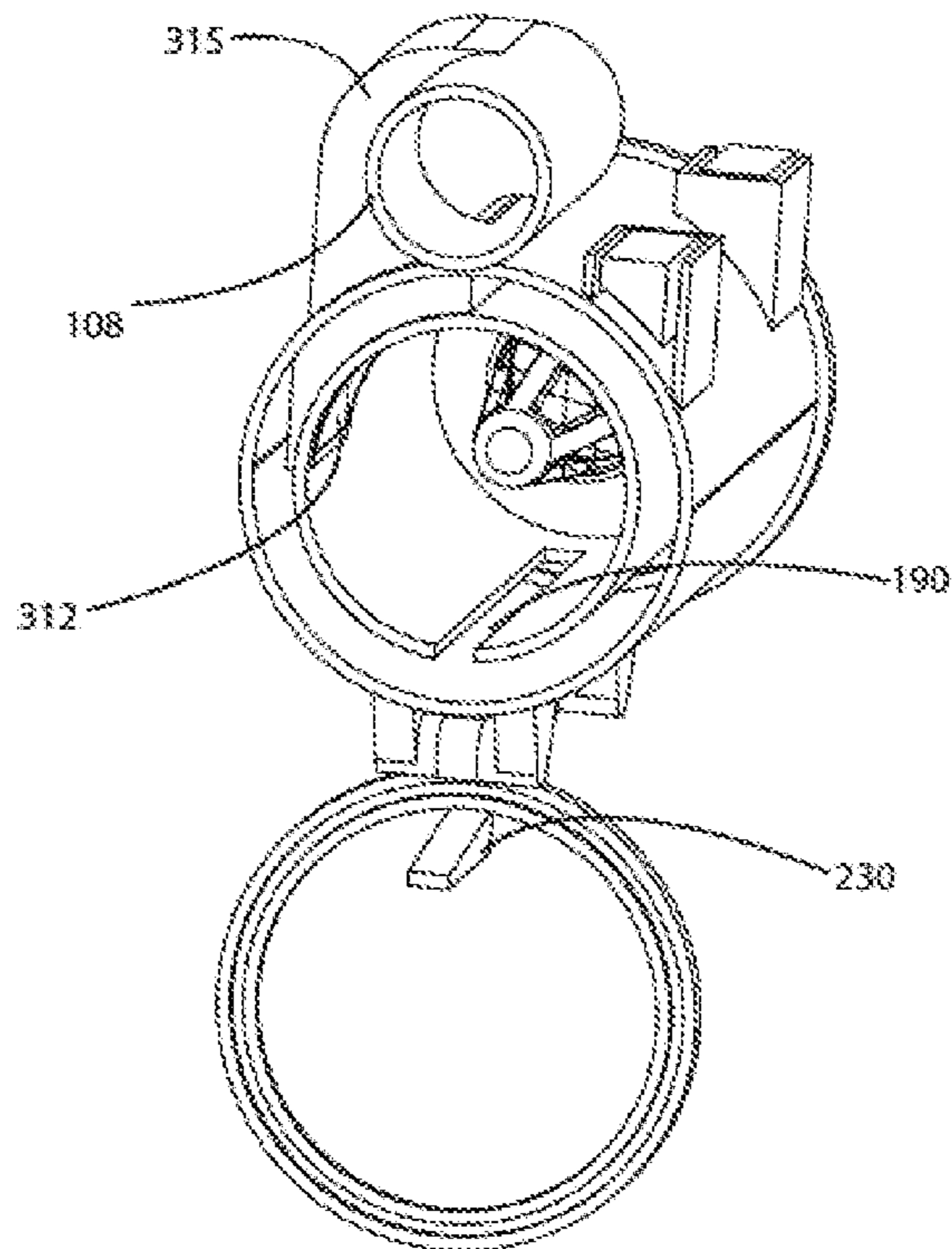


FIG. 44

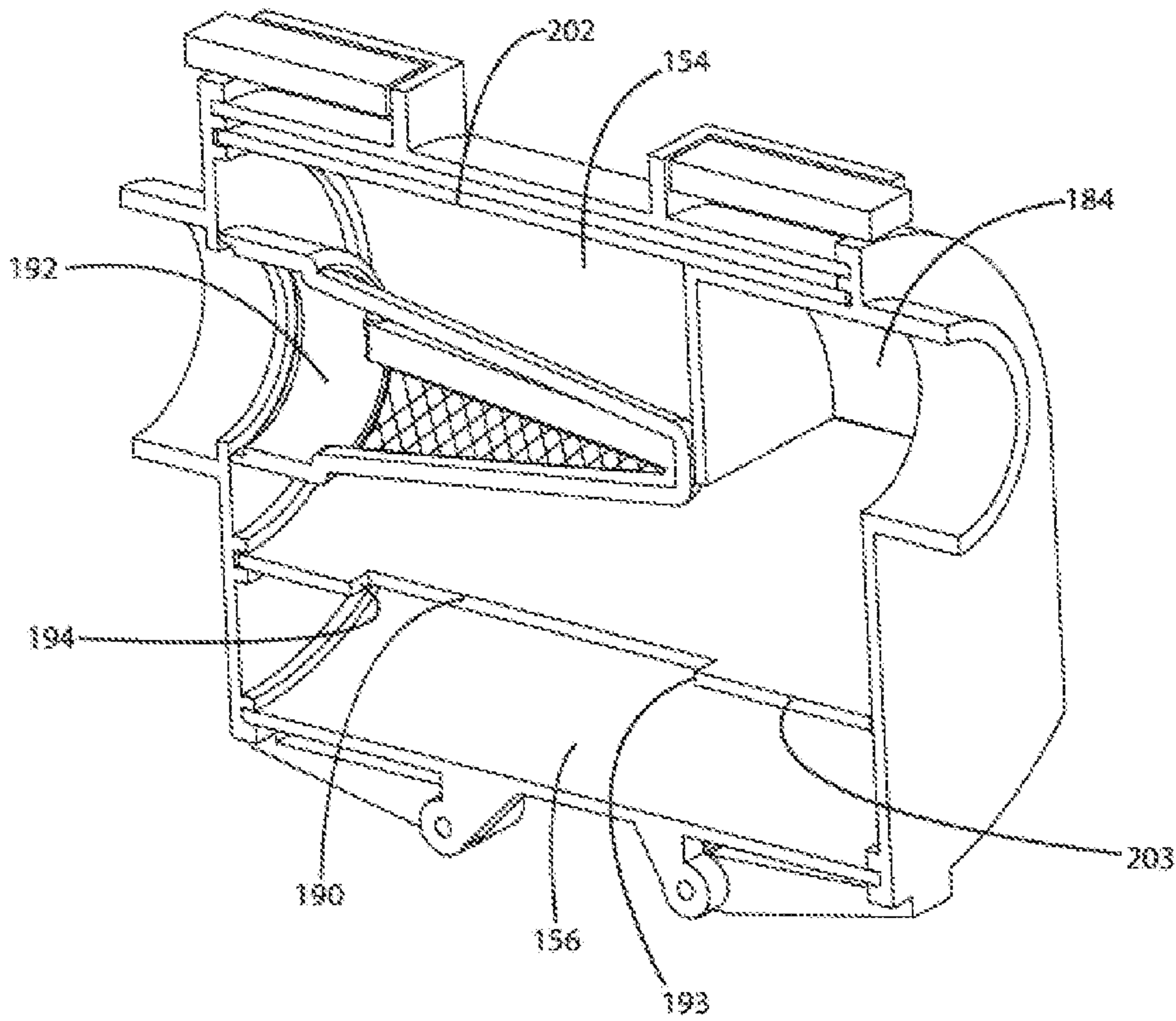


FIG. 45

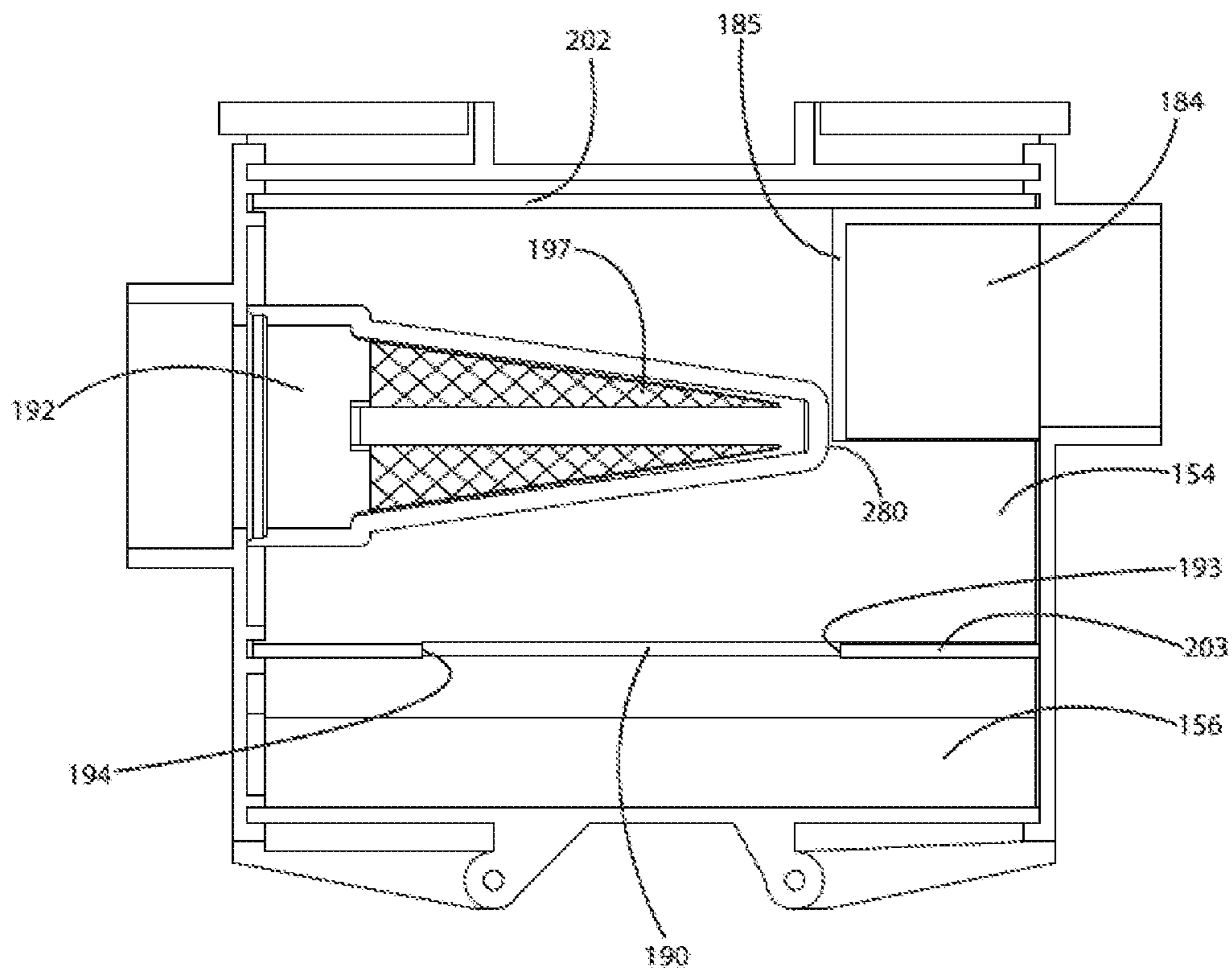


FIG. 46

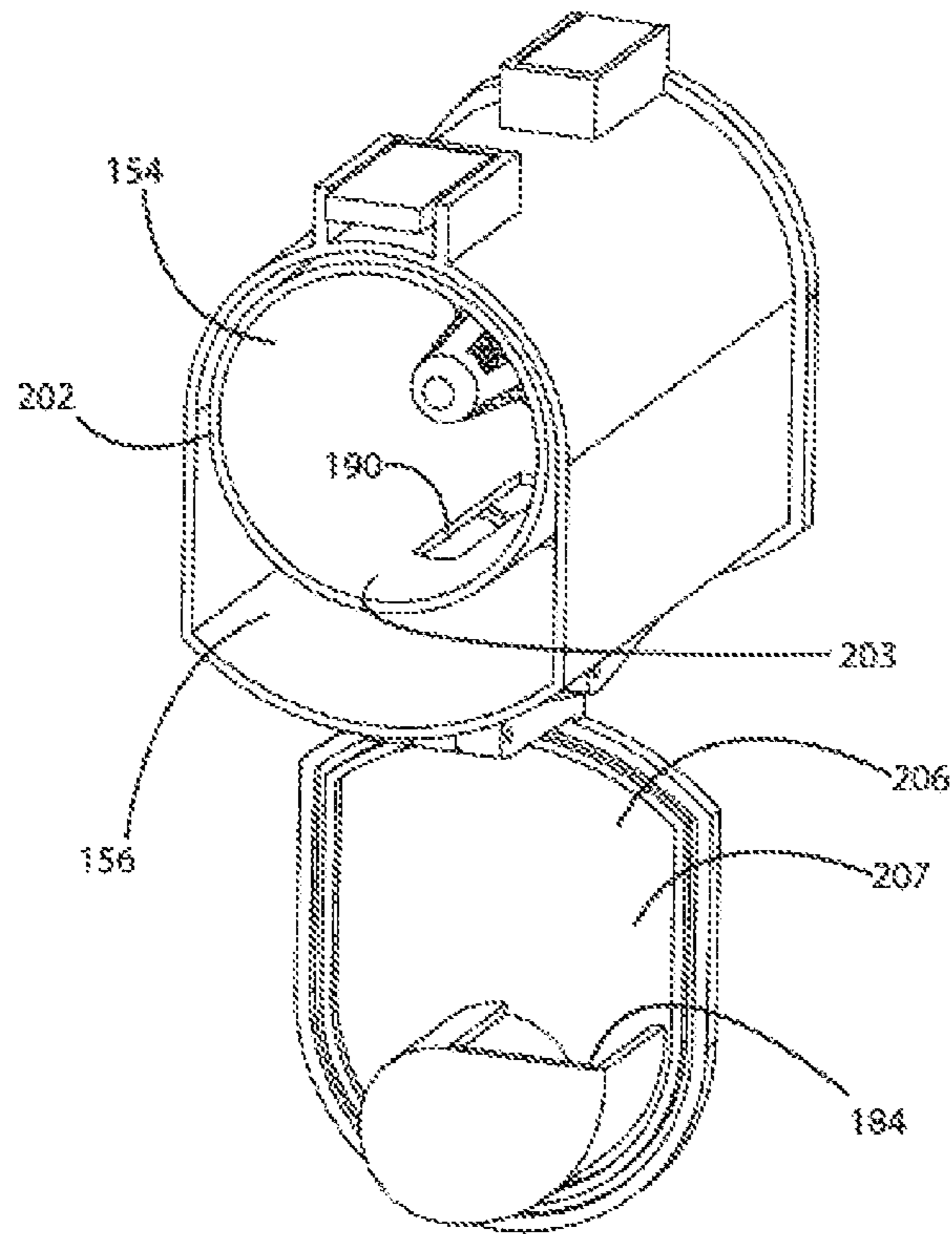


FIG. 47

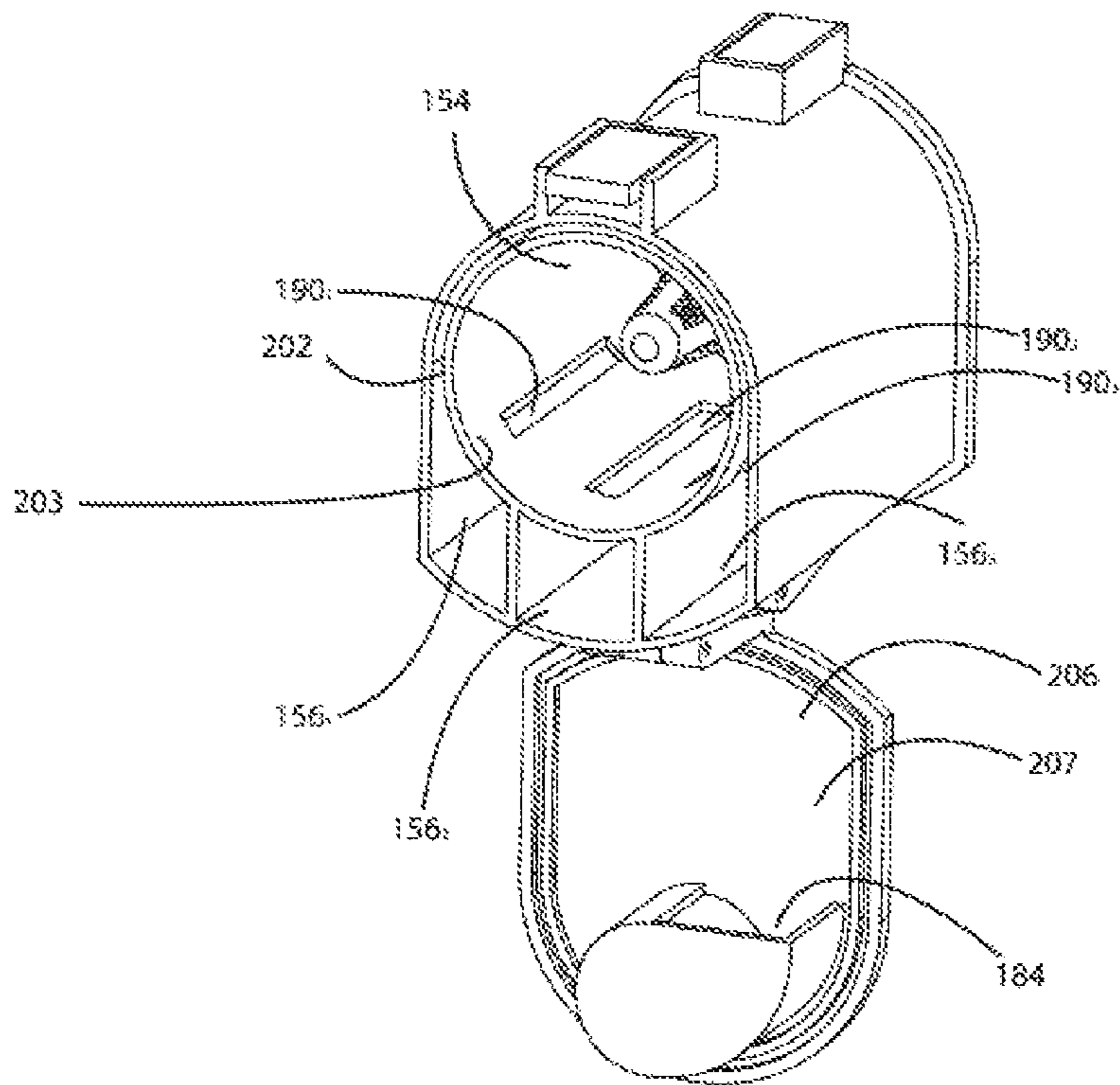


FIG. 48



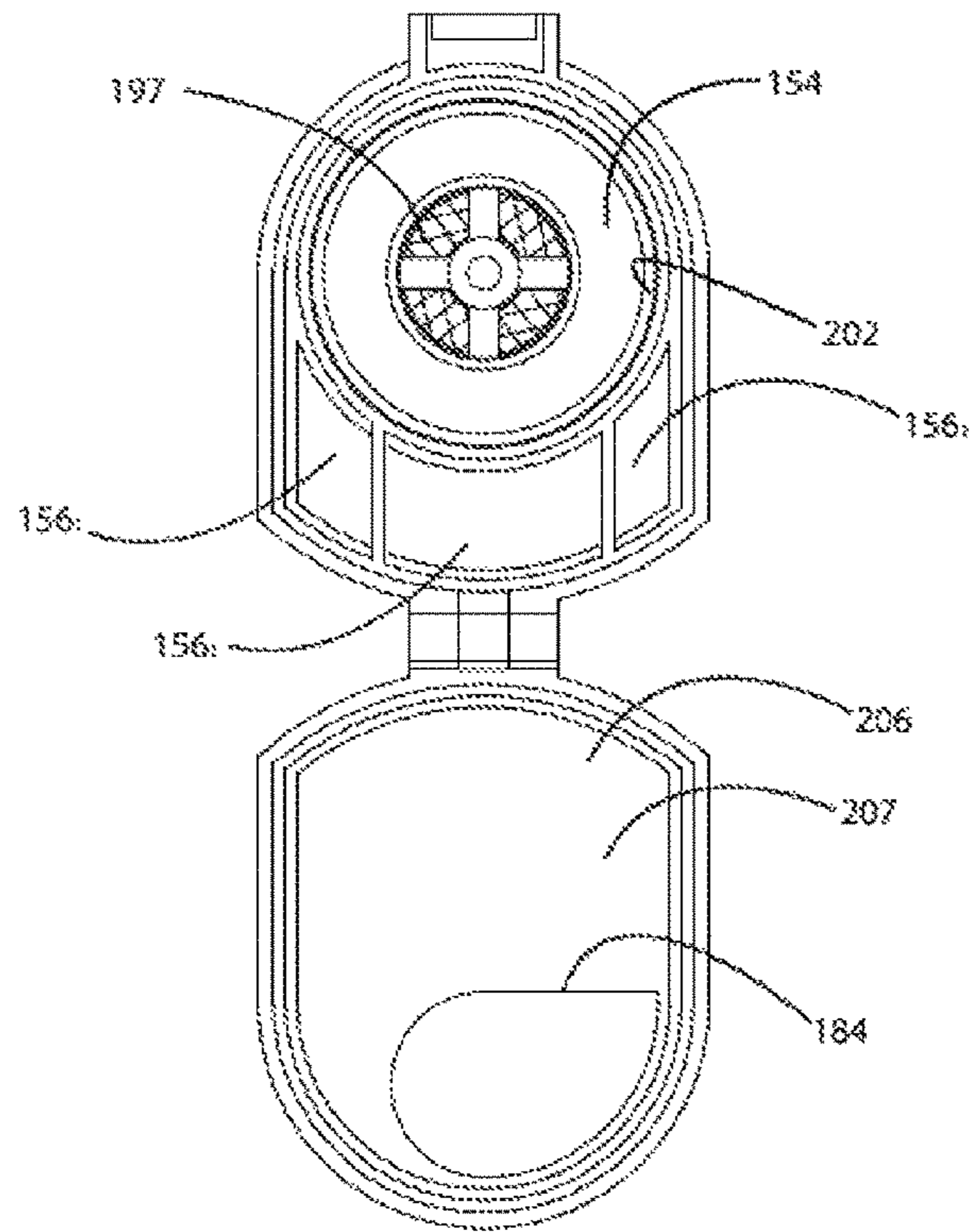


FIG. 49

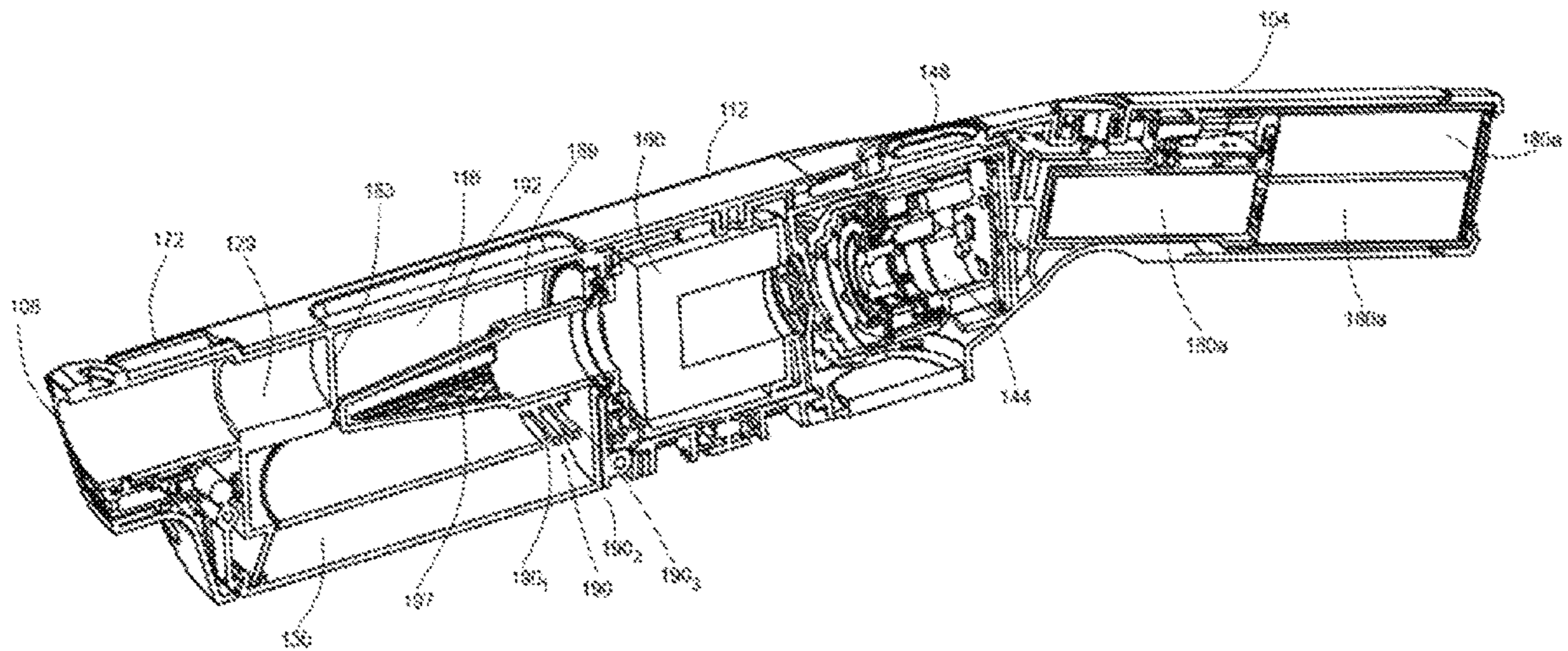


FIG. 50

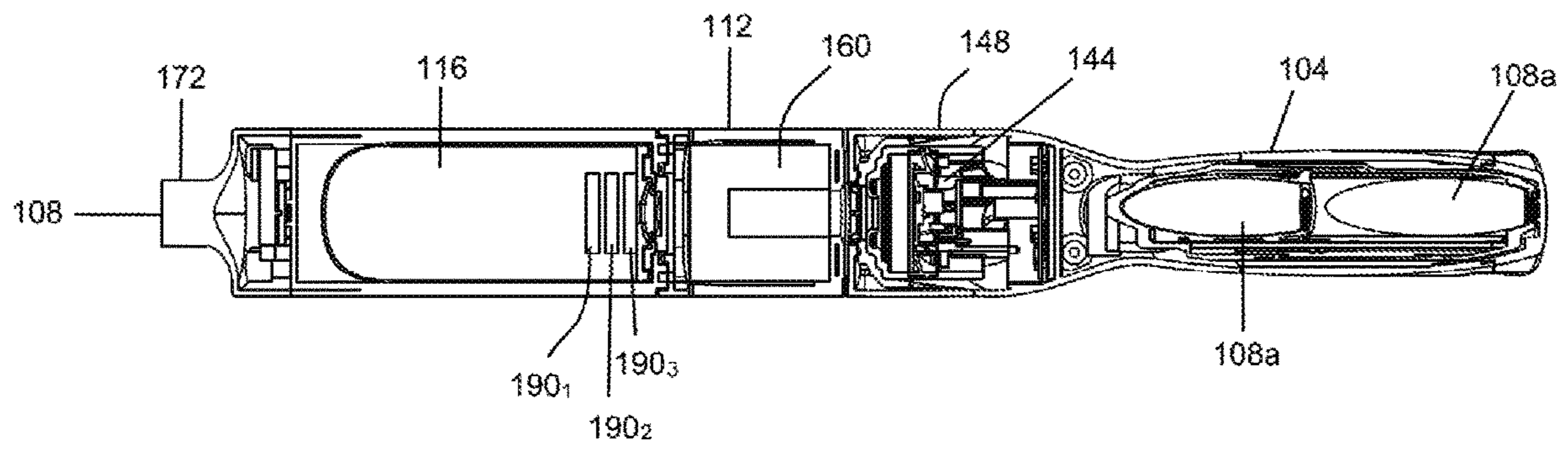


FIG. 51

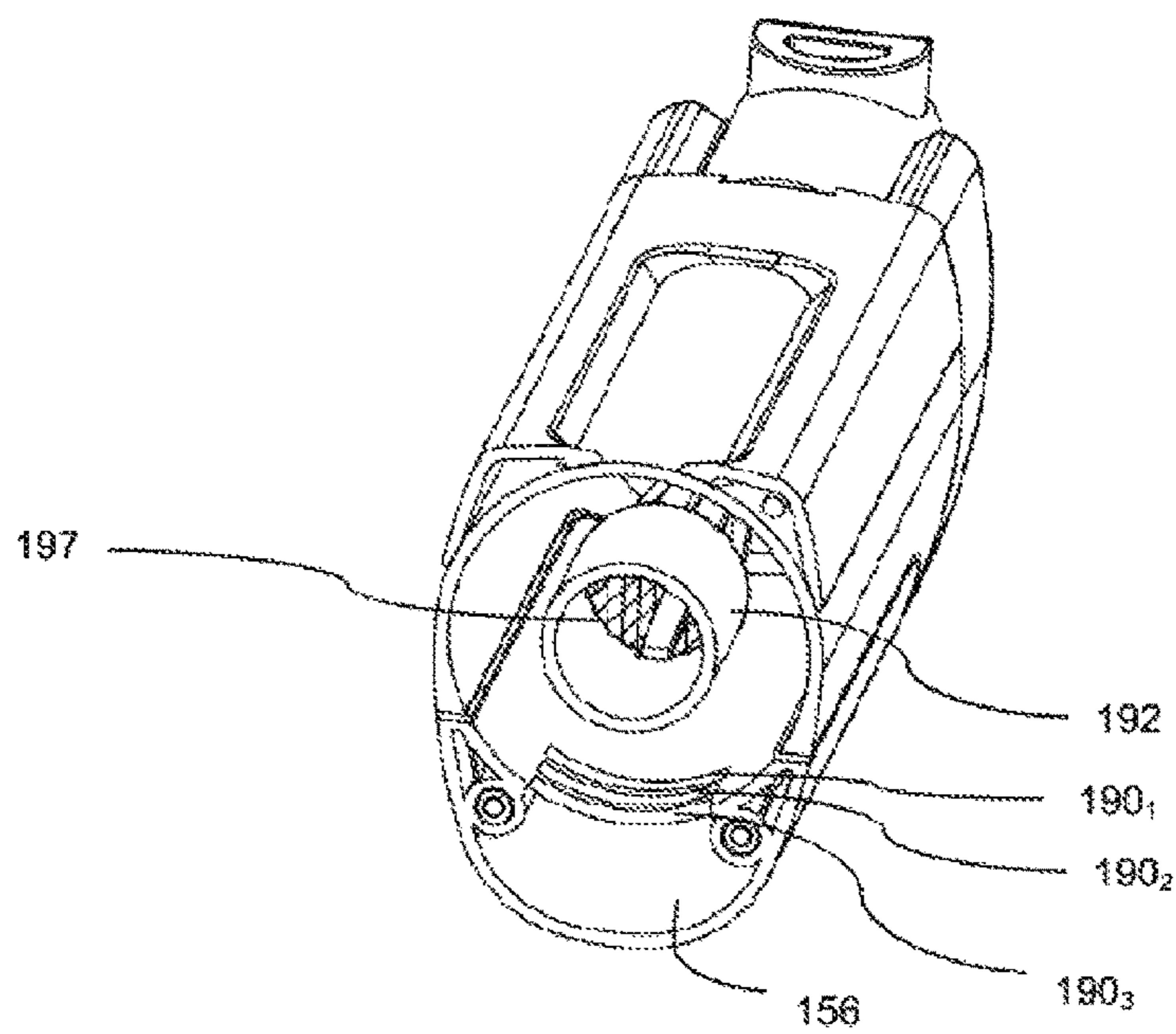


FIG. 52

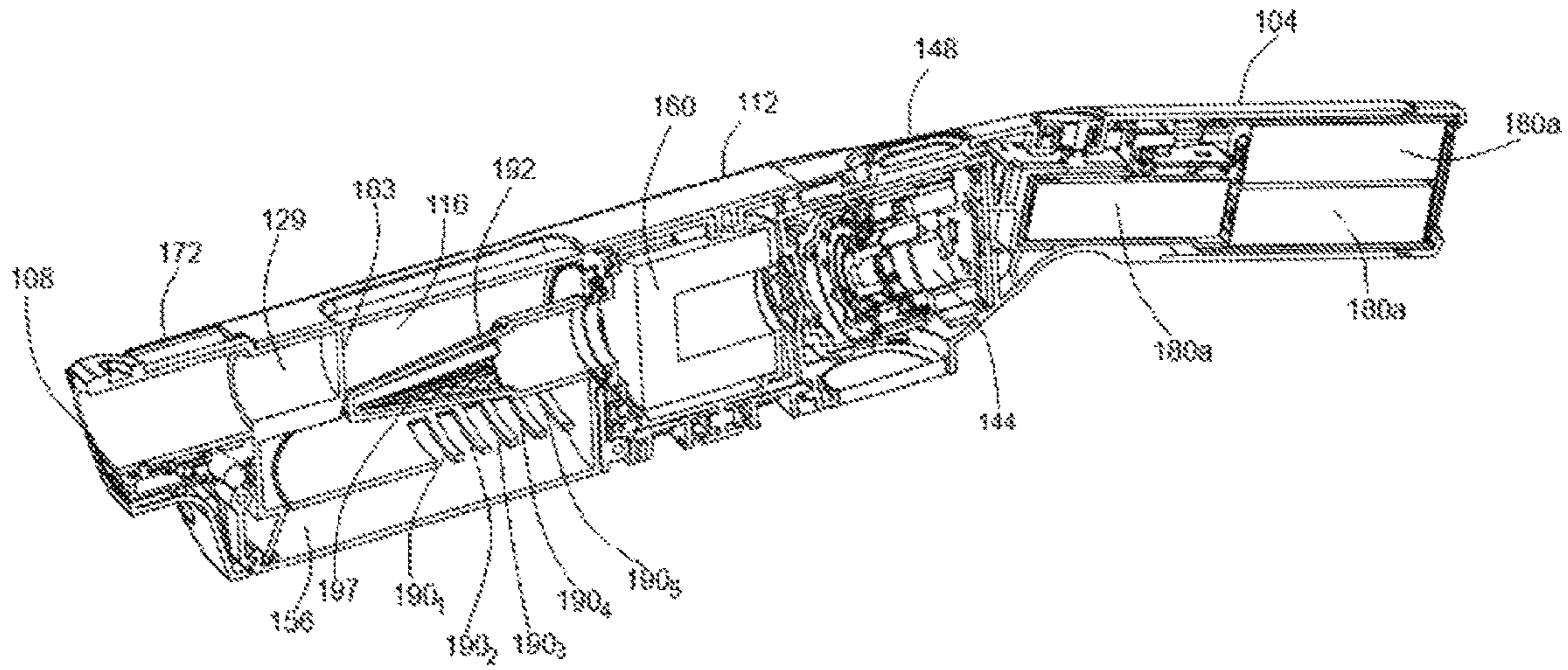


FIG. 53

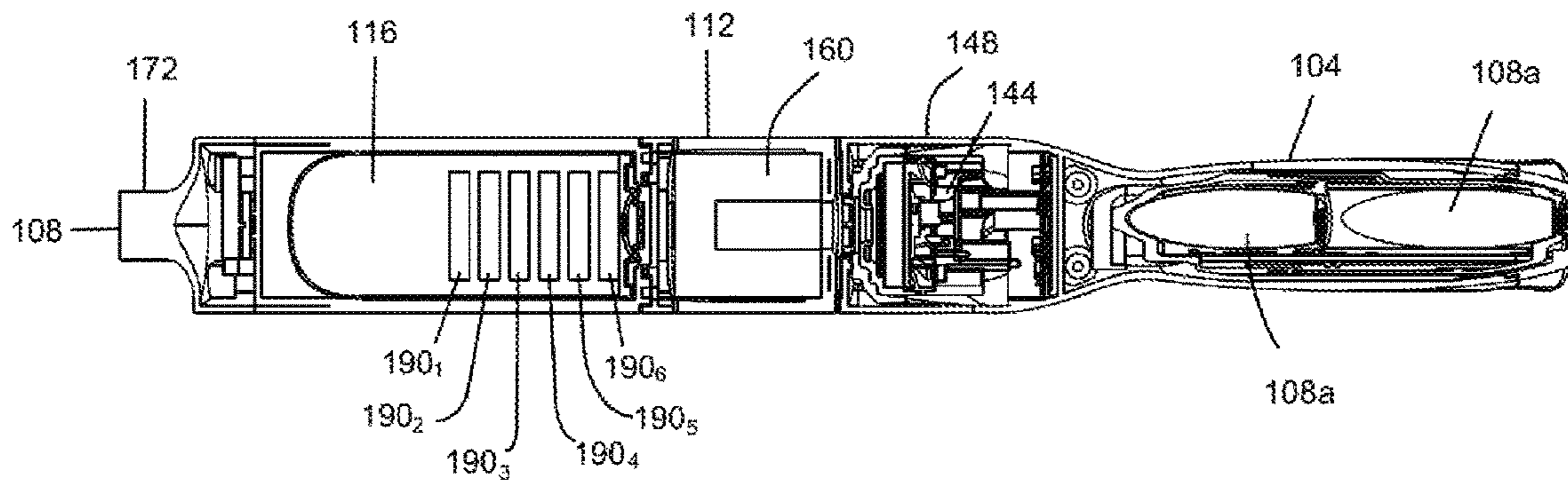


FIG. 54

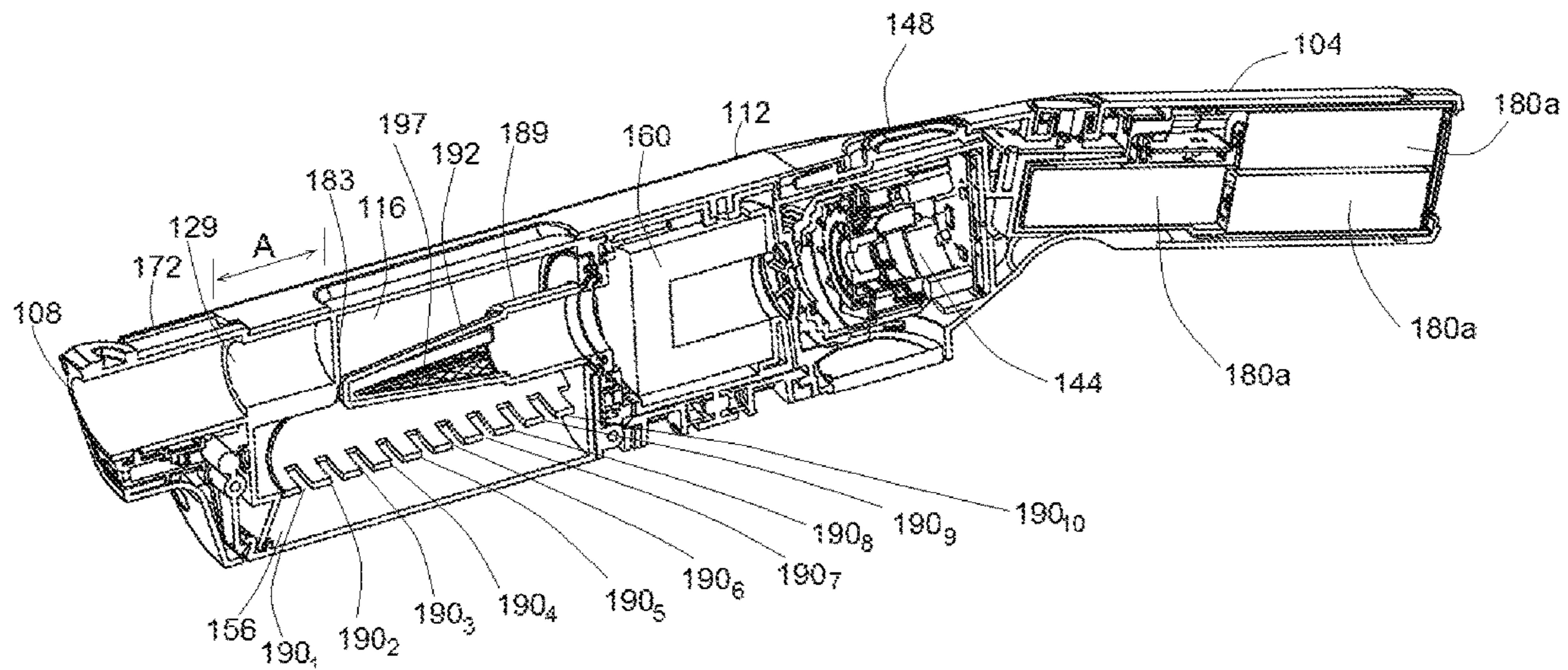


FIG. 55

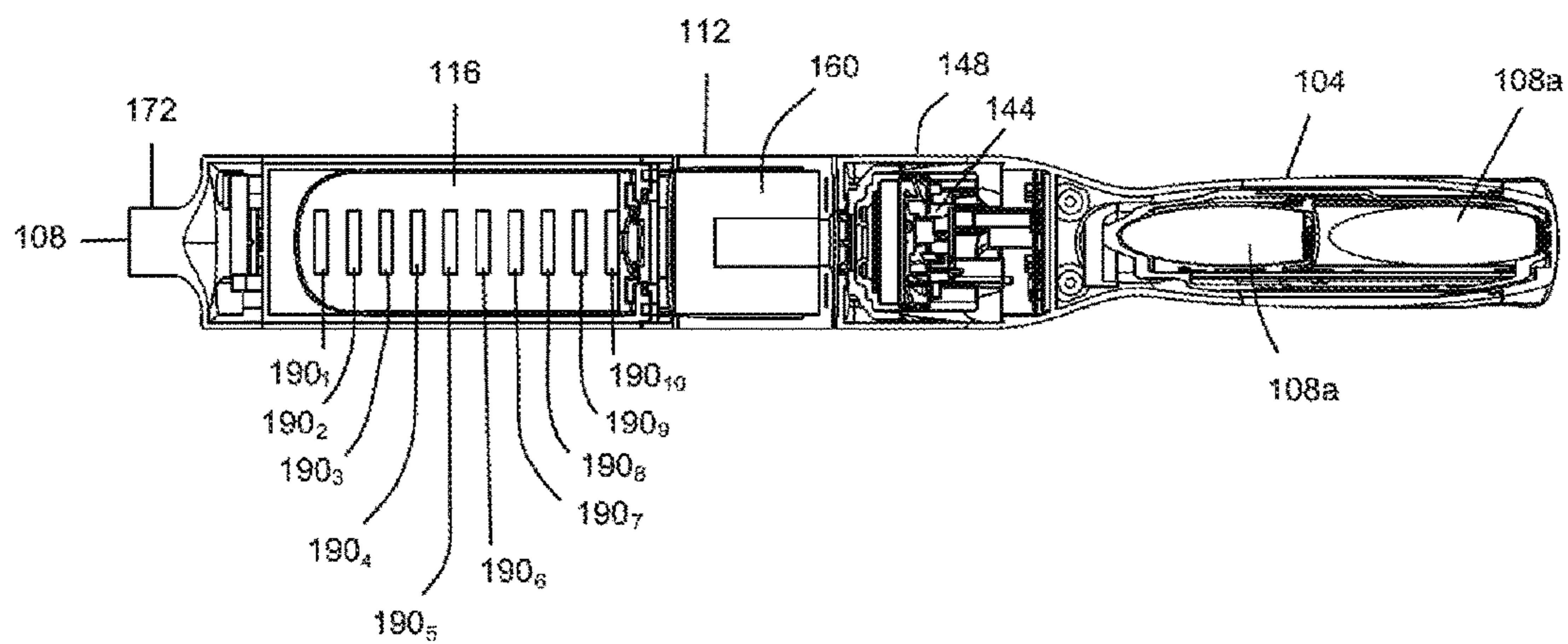


FIG. 56

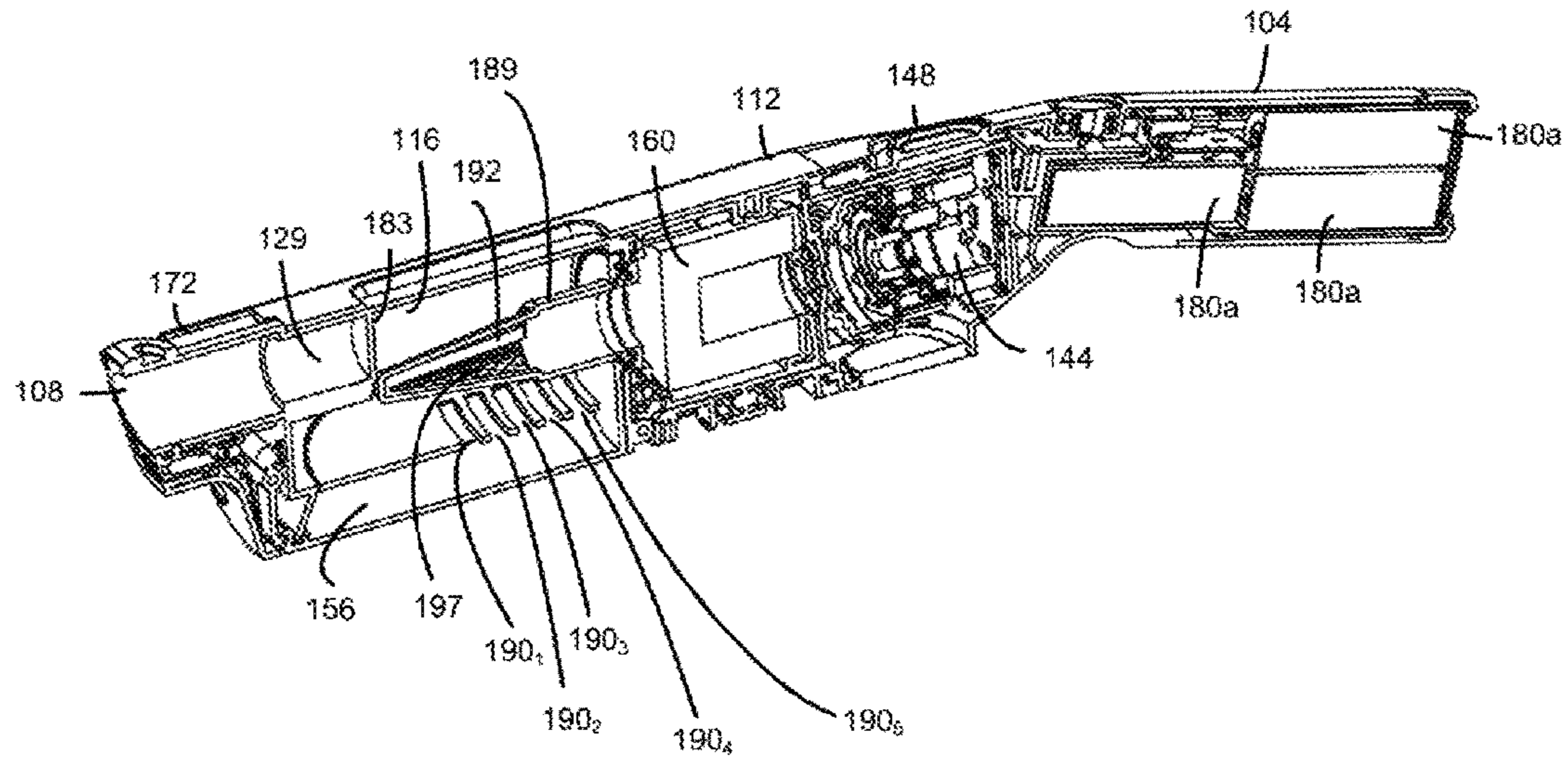


FIG. 57

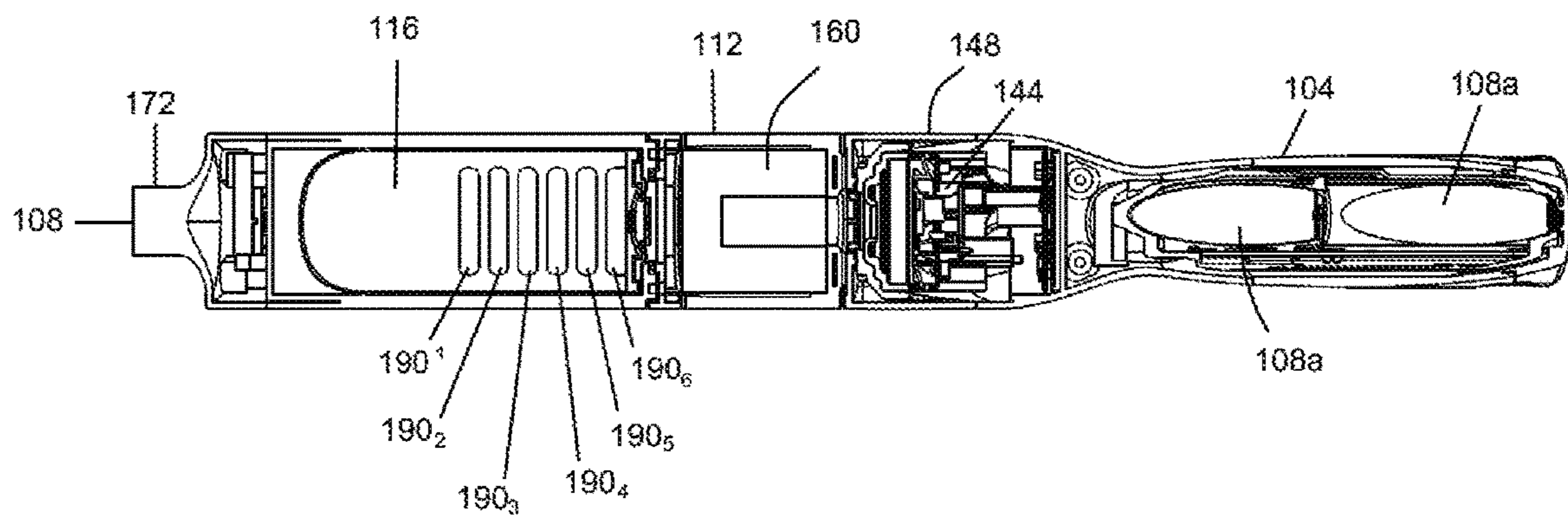


FIG. 58

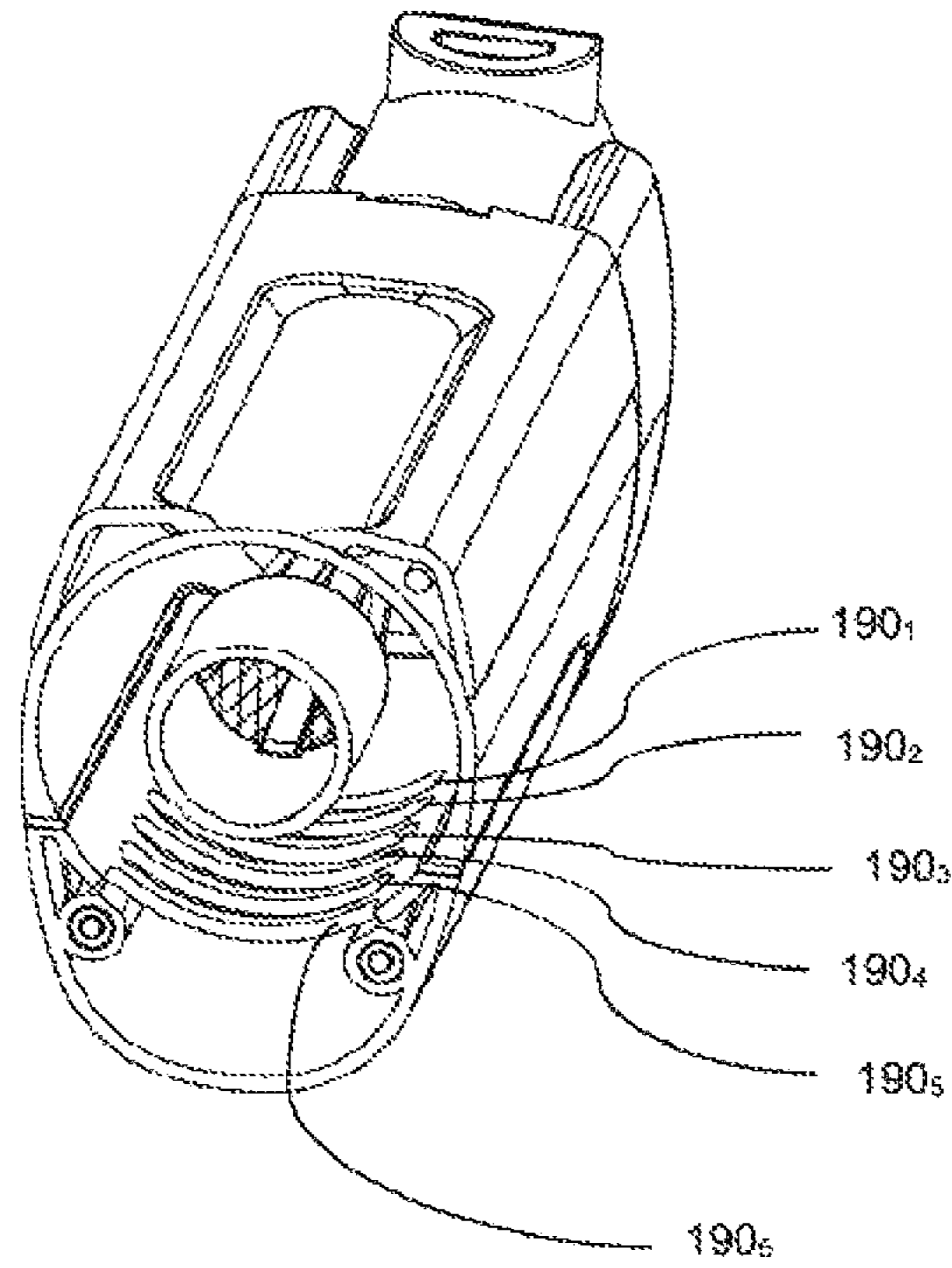


FIG. 59

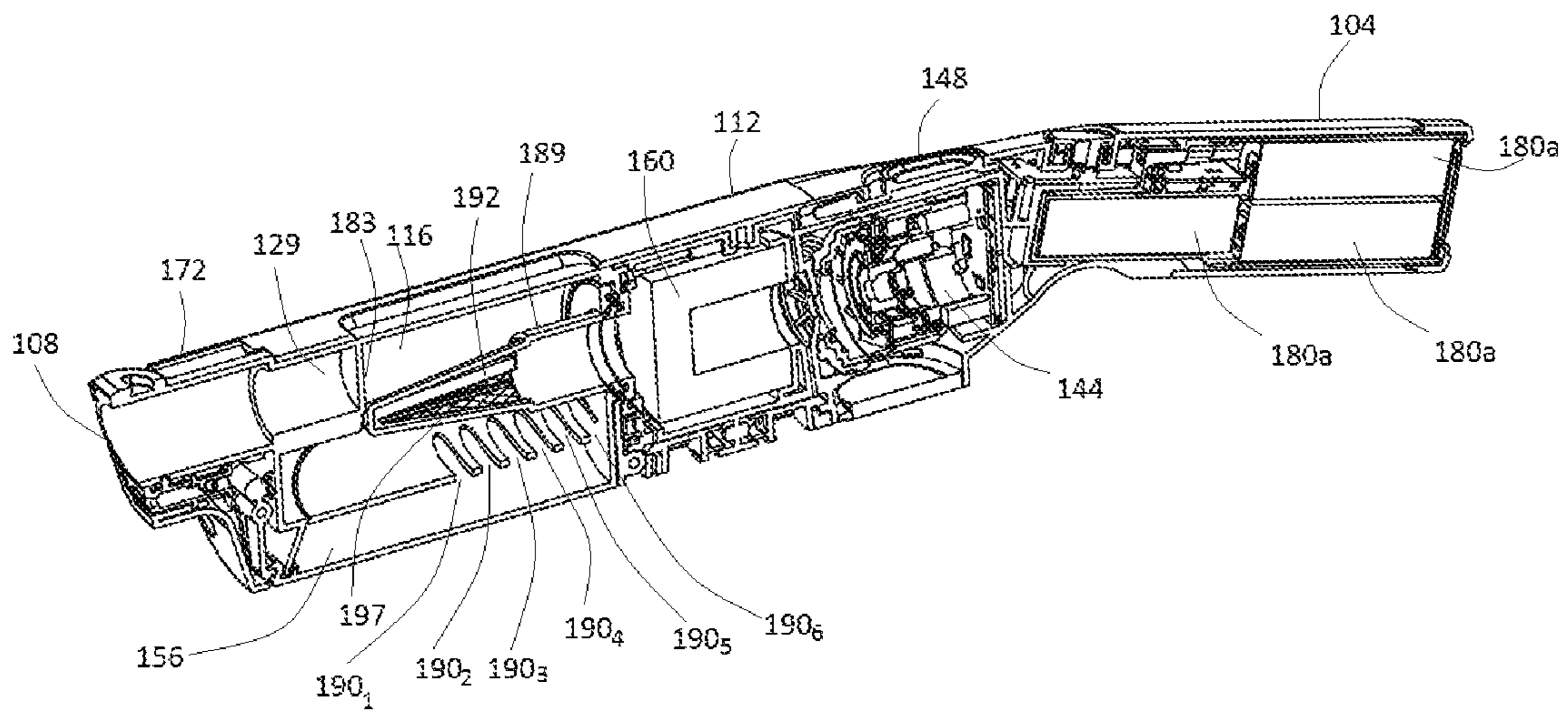


FIG. 60

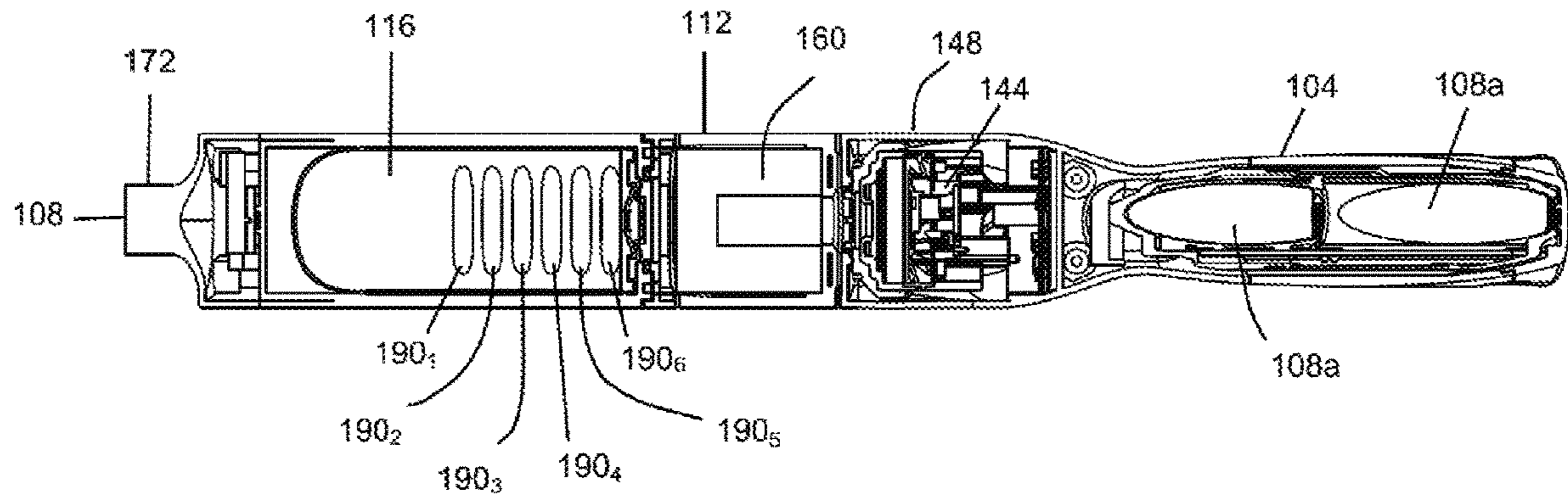


FIG. 61

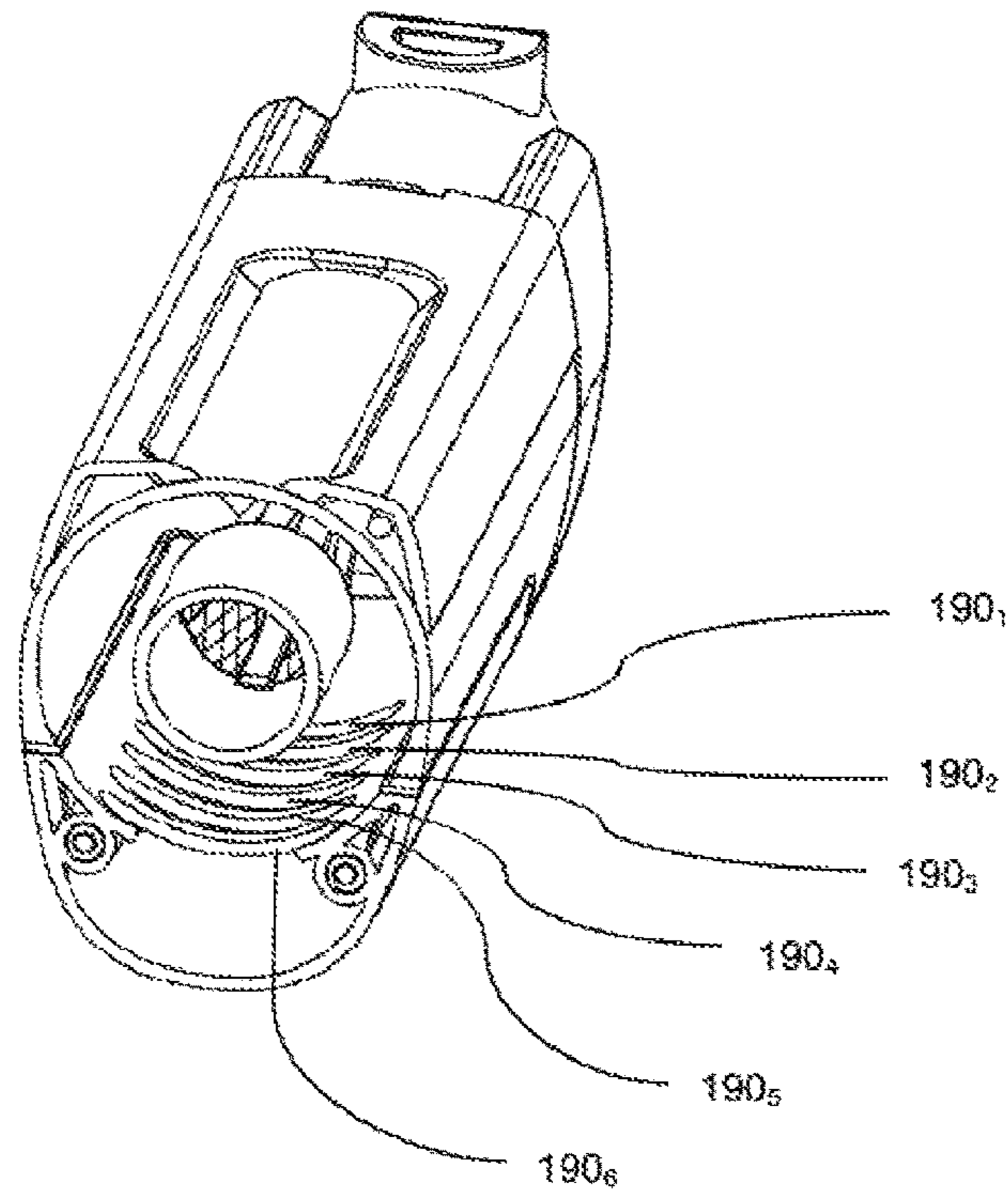


FIG. 62

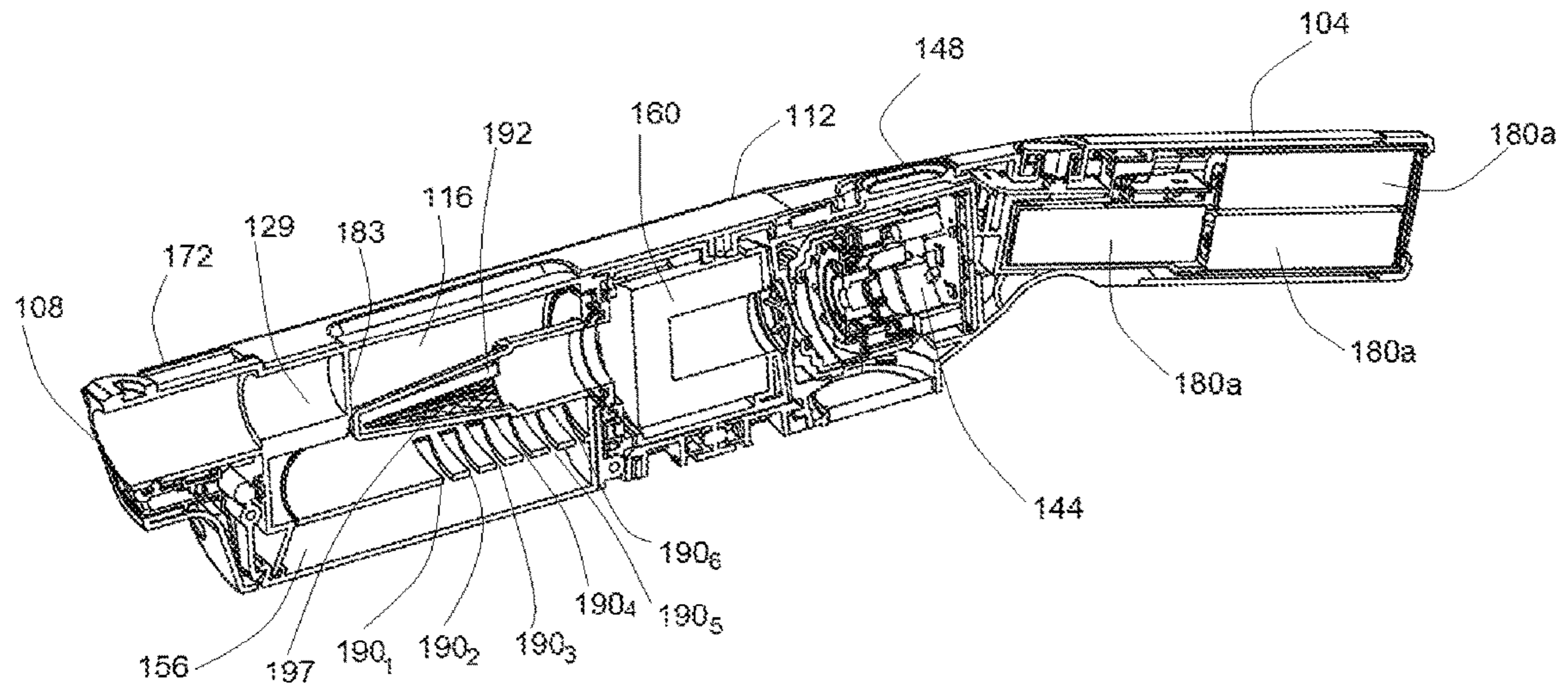


FIG. 63

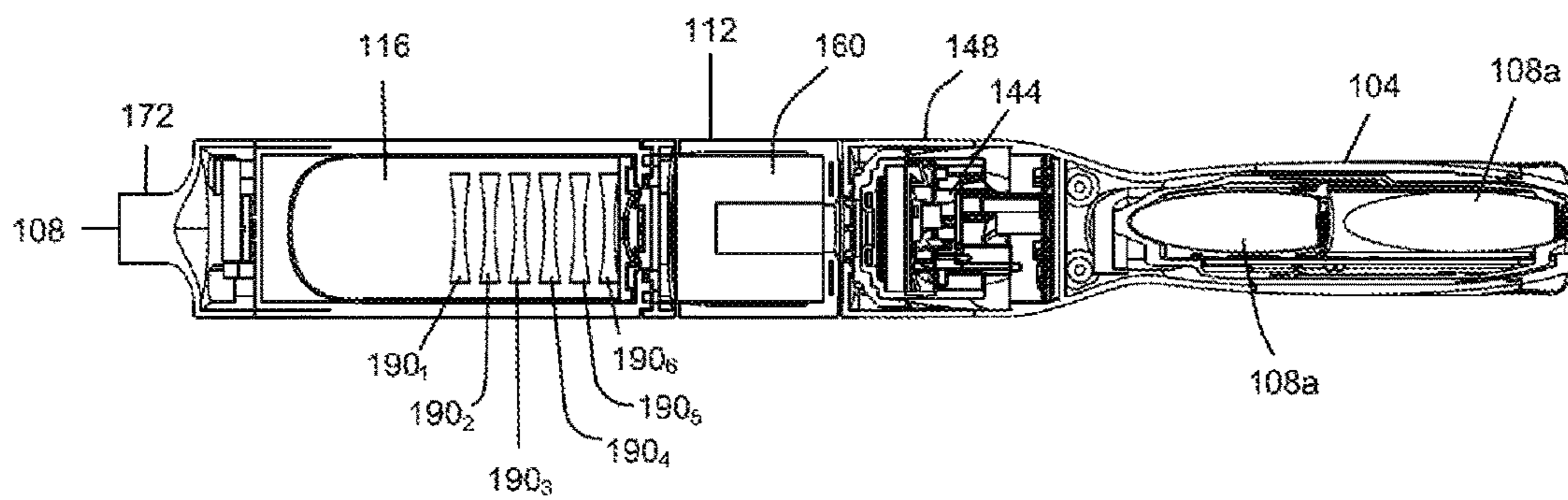


FIG. 64



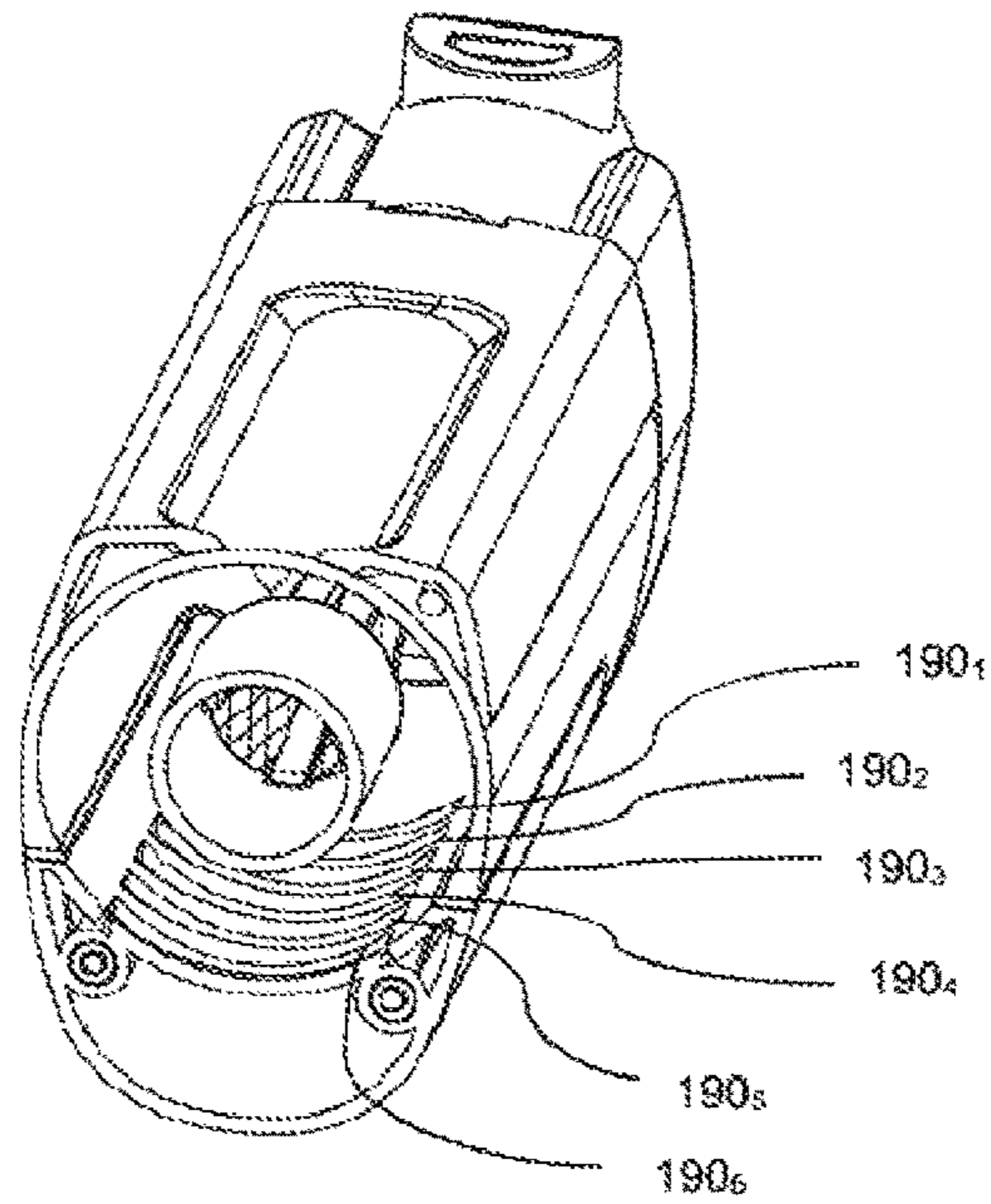


FIG. 65

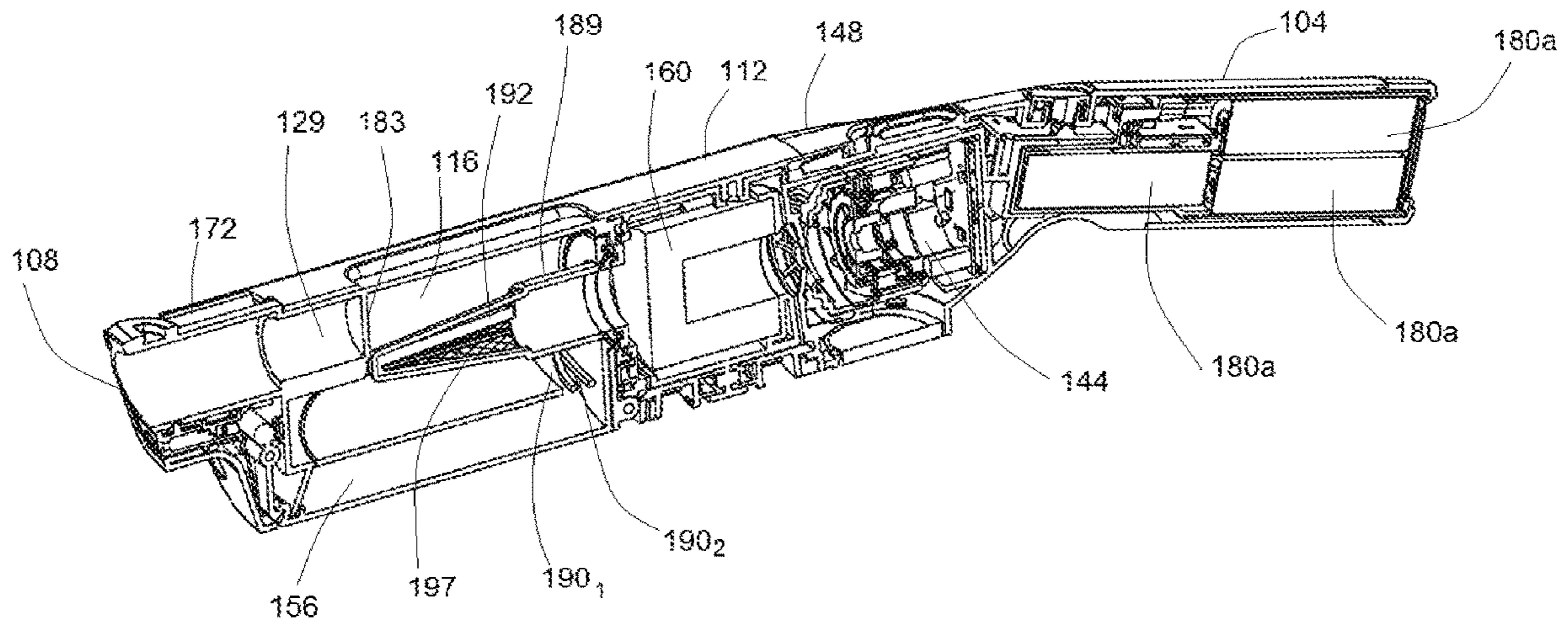


FIG. 66

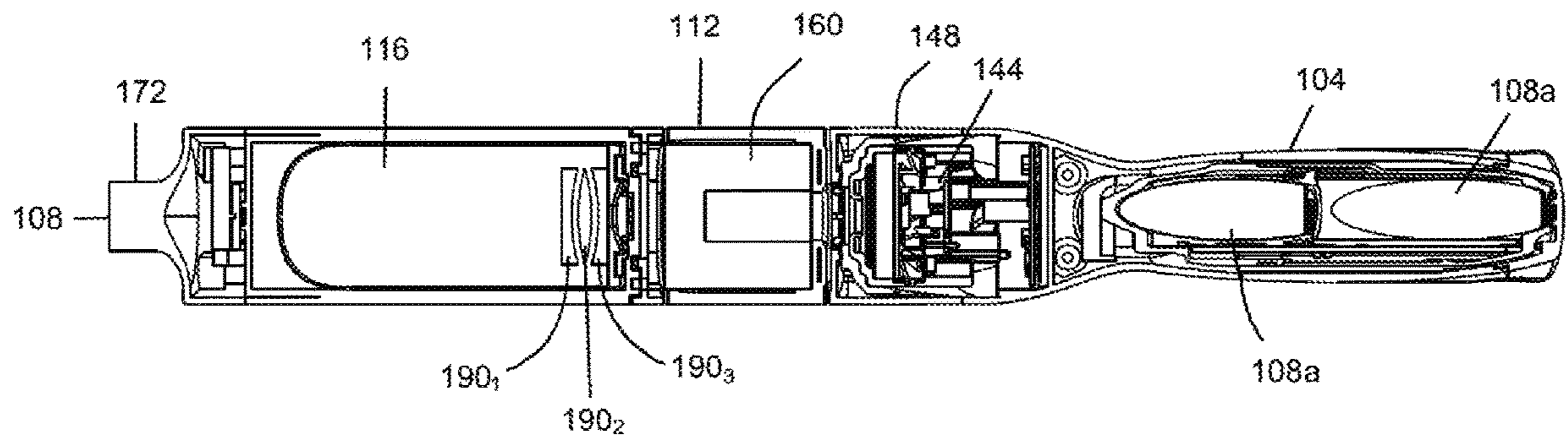


FIG. 67

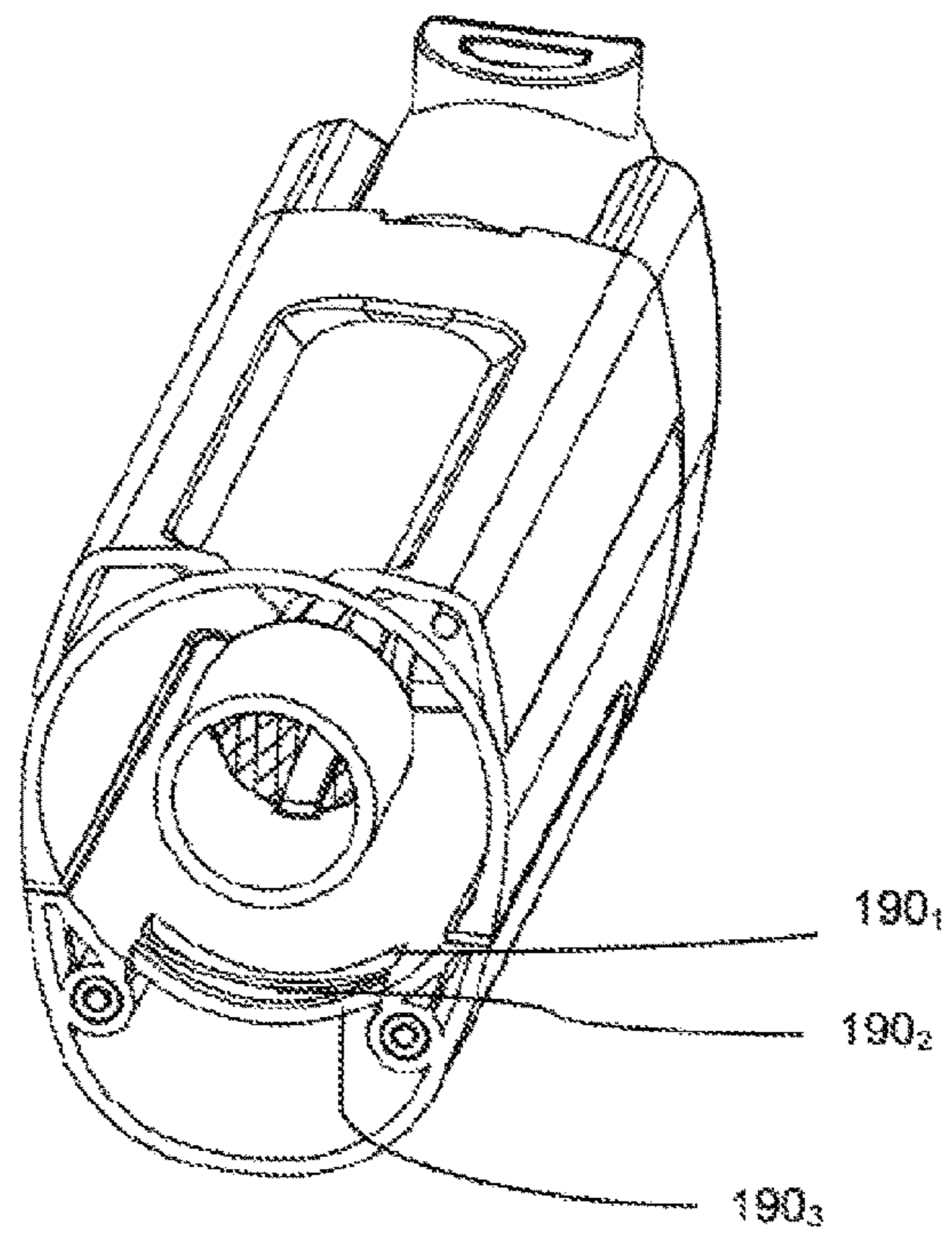


FIG. 68

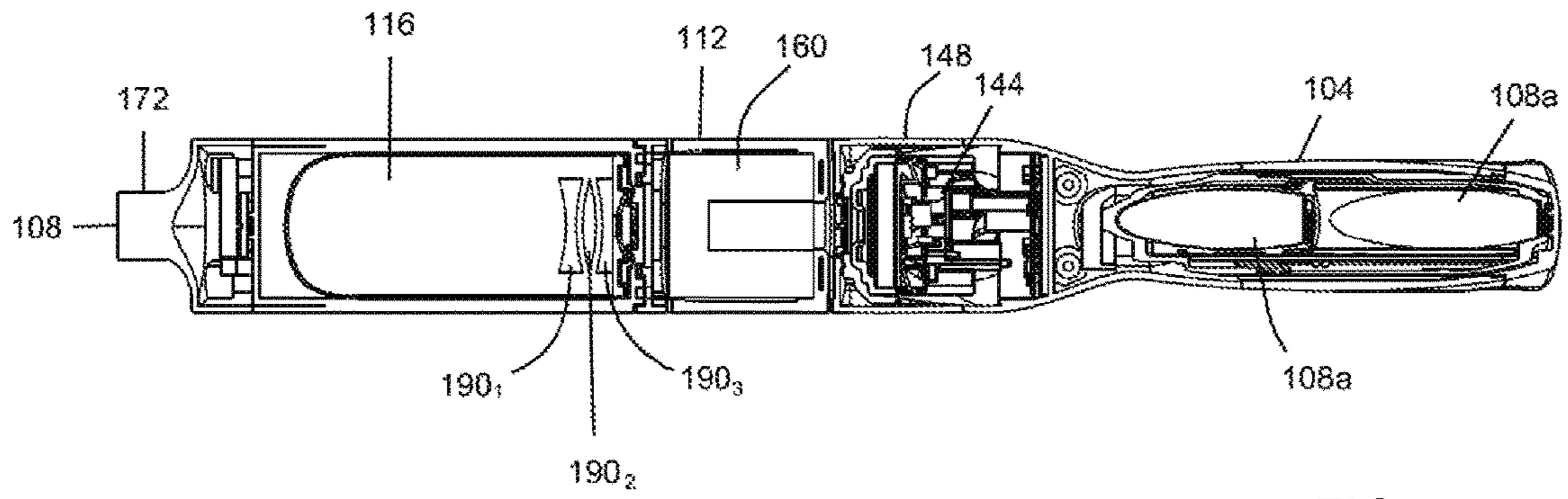


FIG. 69

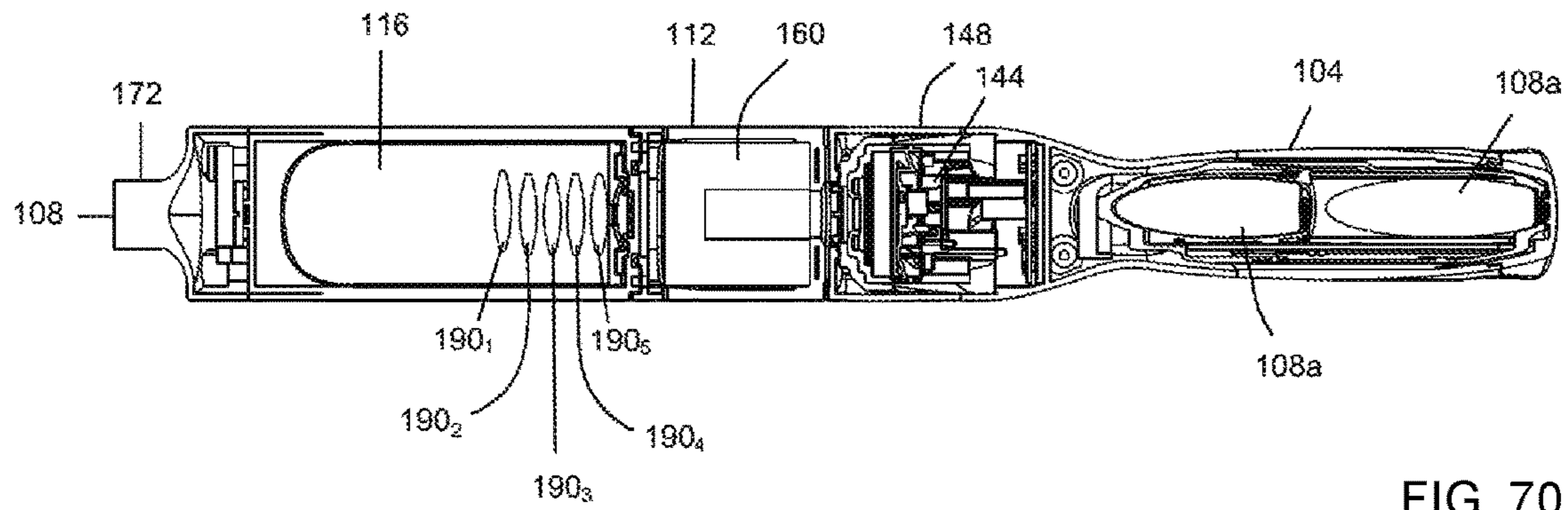


FIG. 70

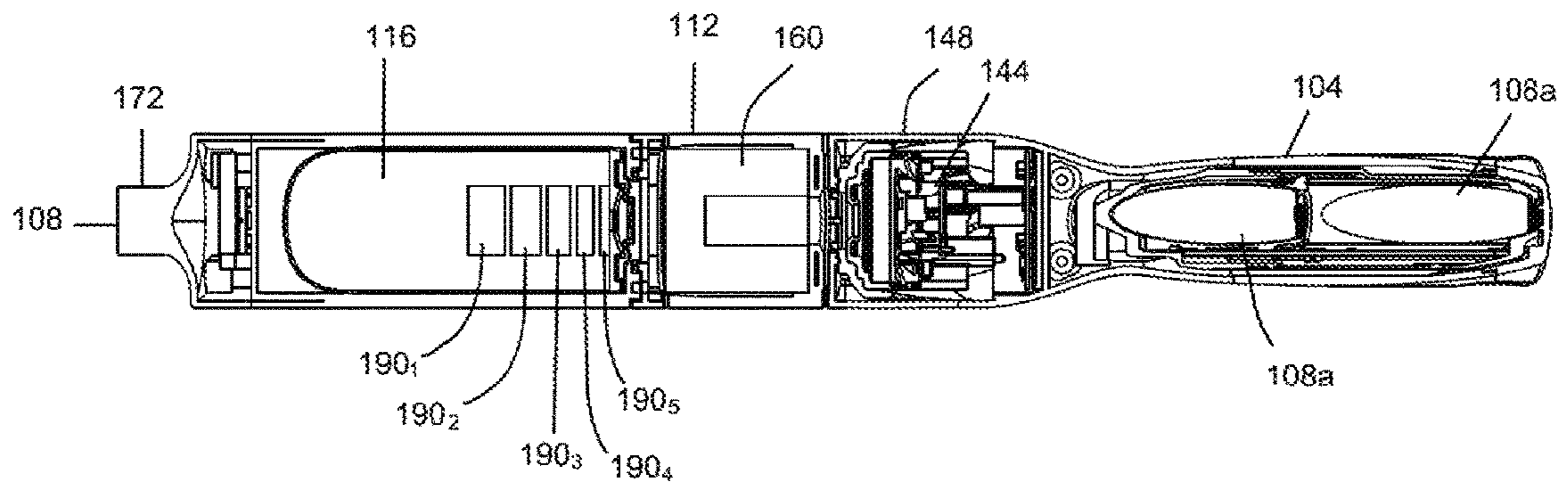
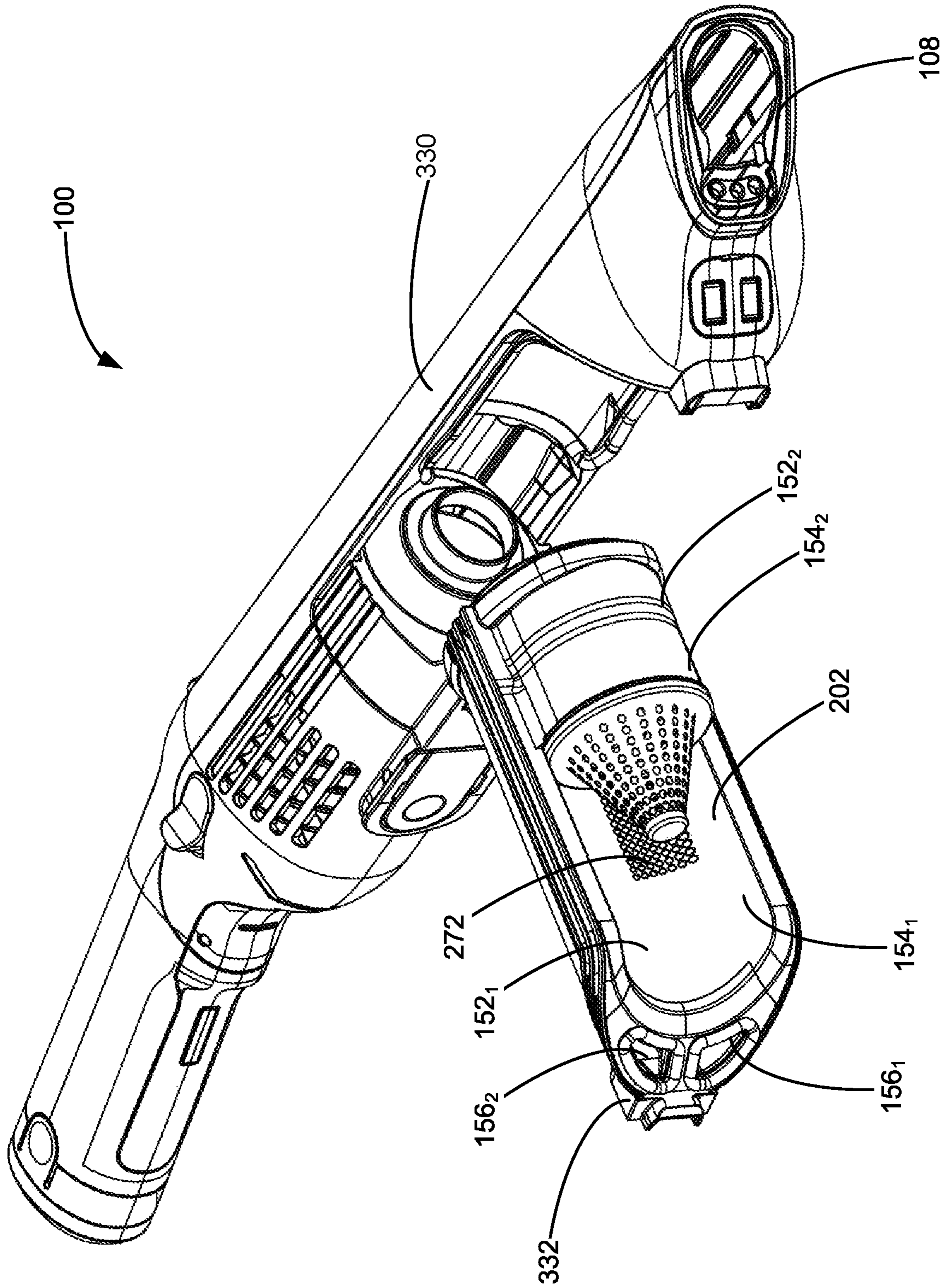
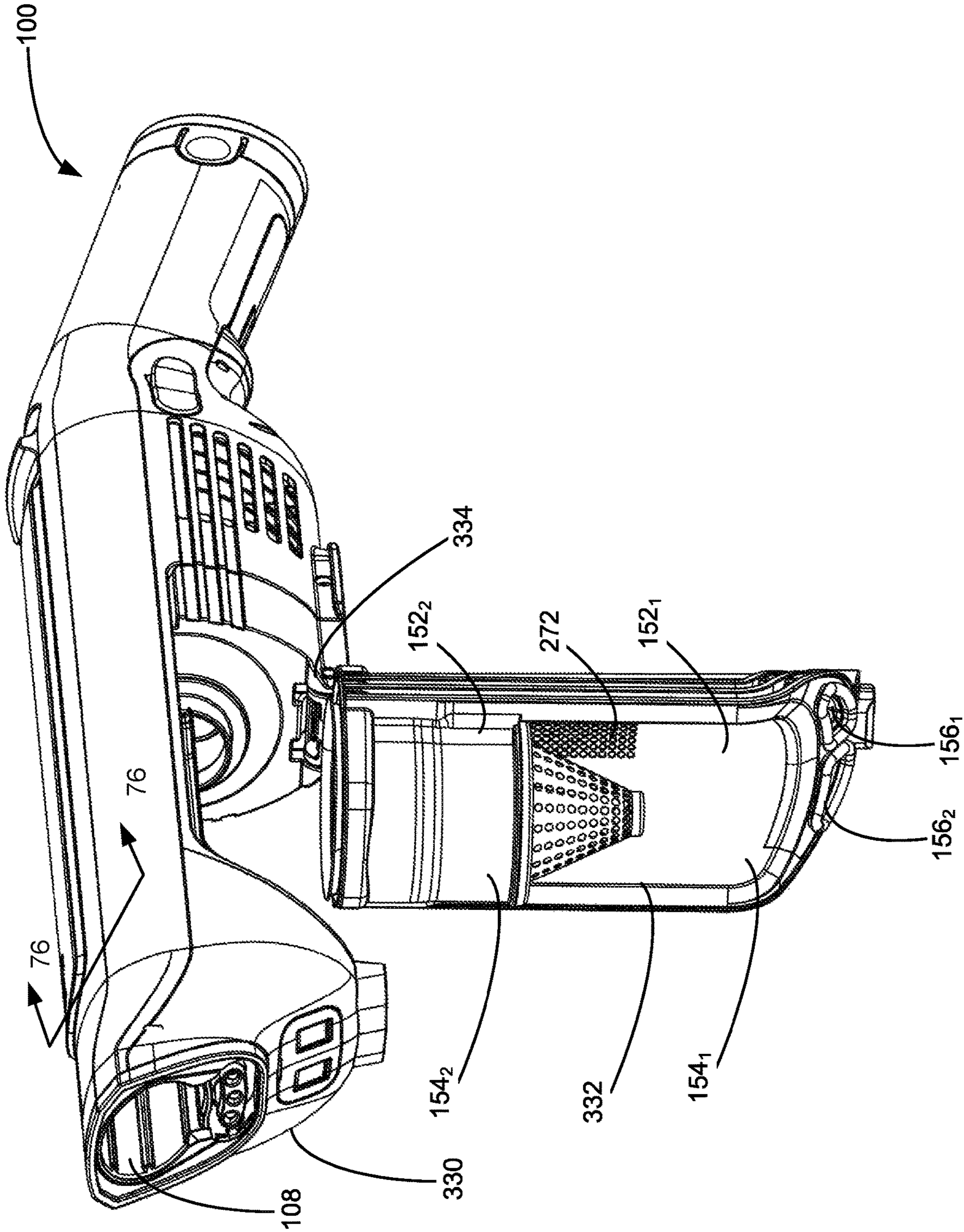


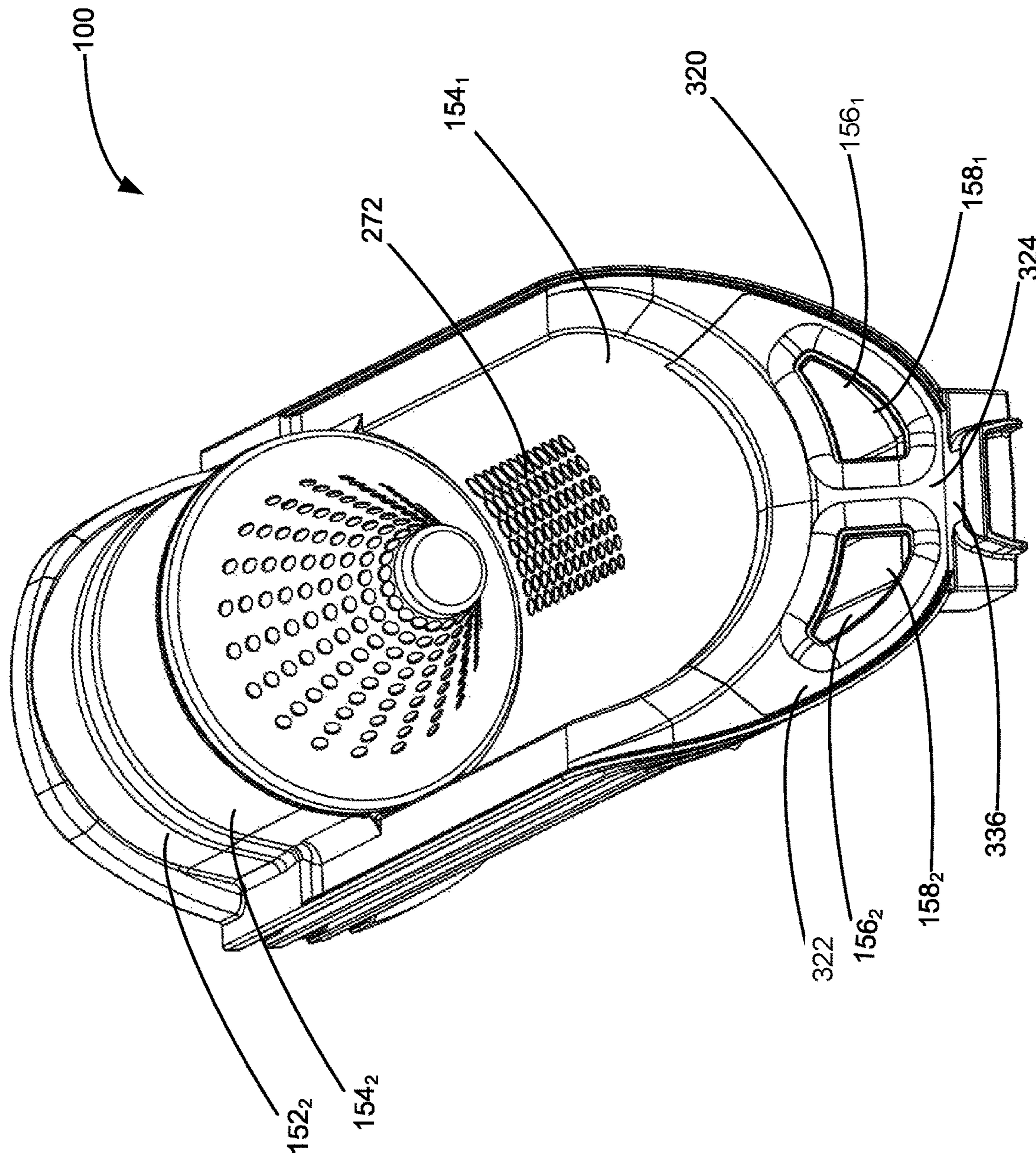
FIG. 71



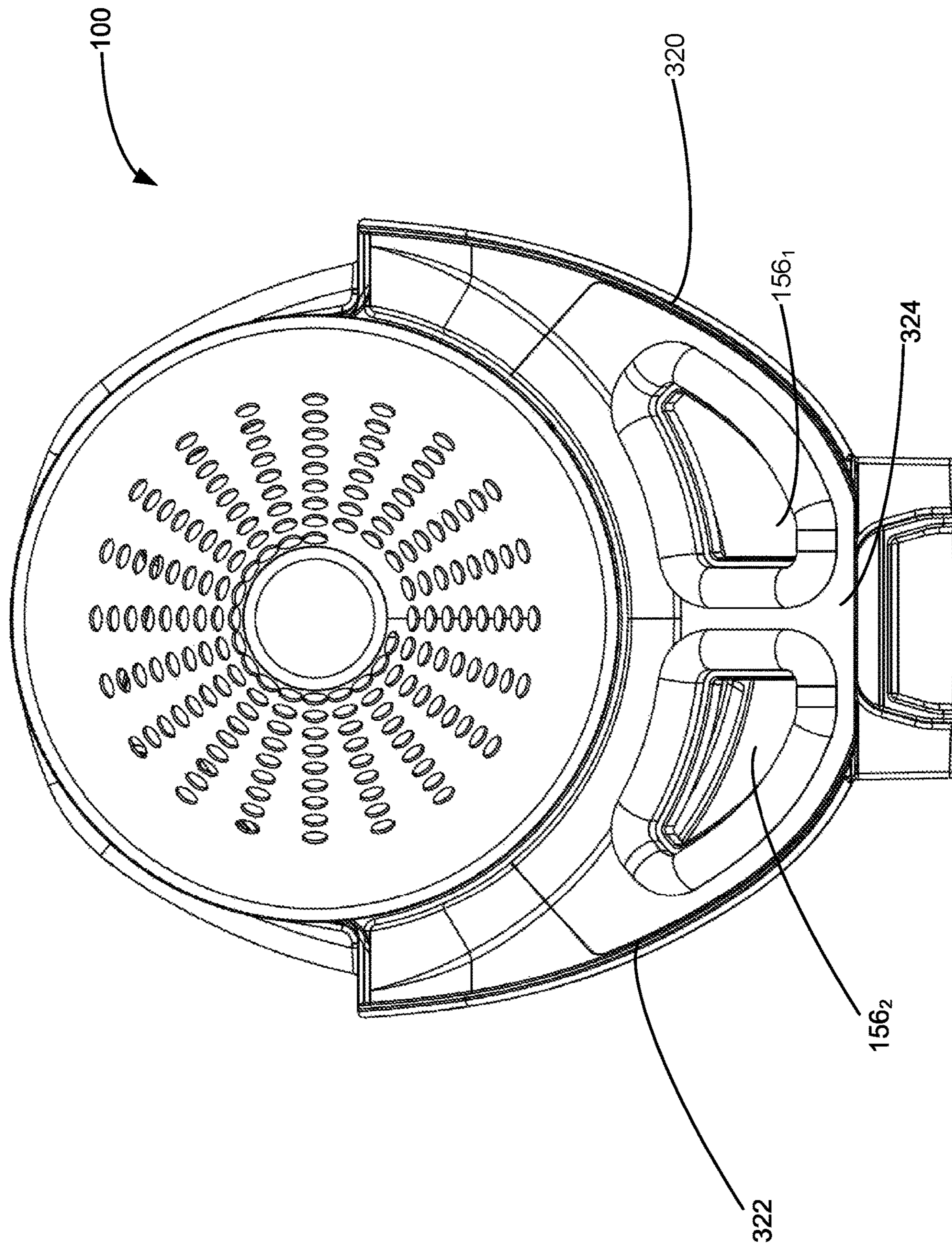
**FIG. 72**



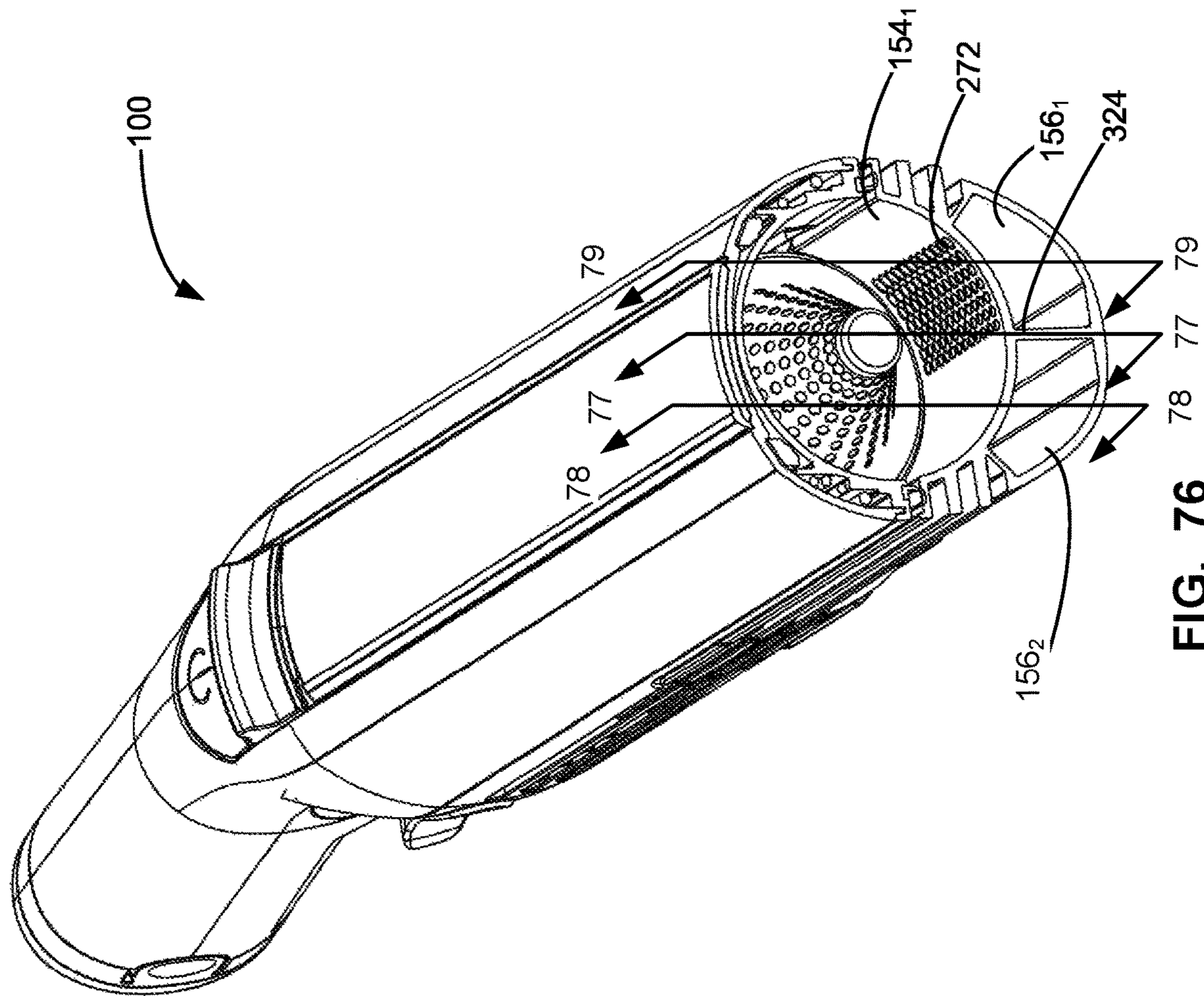
**FIG. 73**



**FIG. 74**

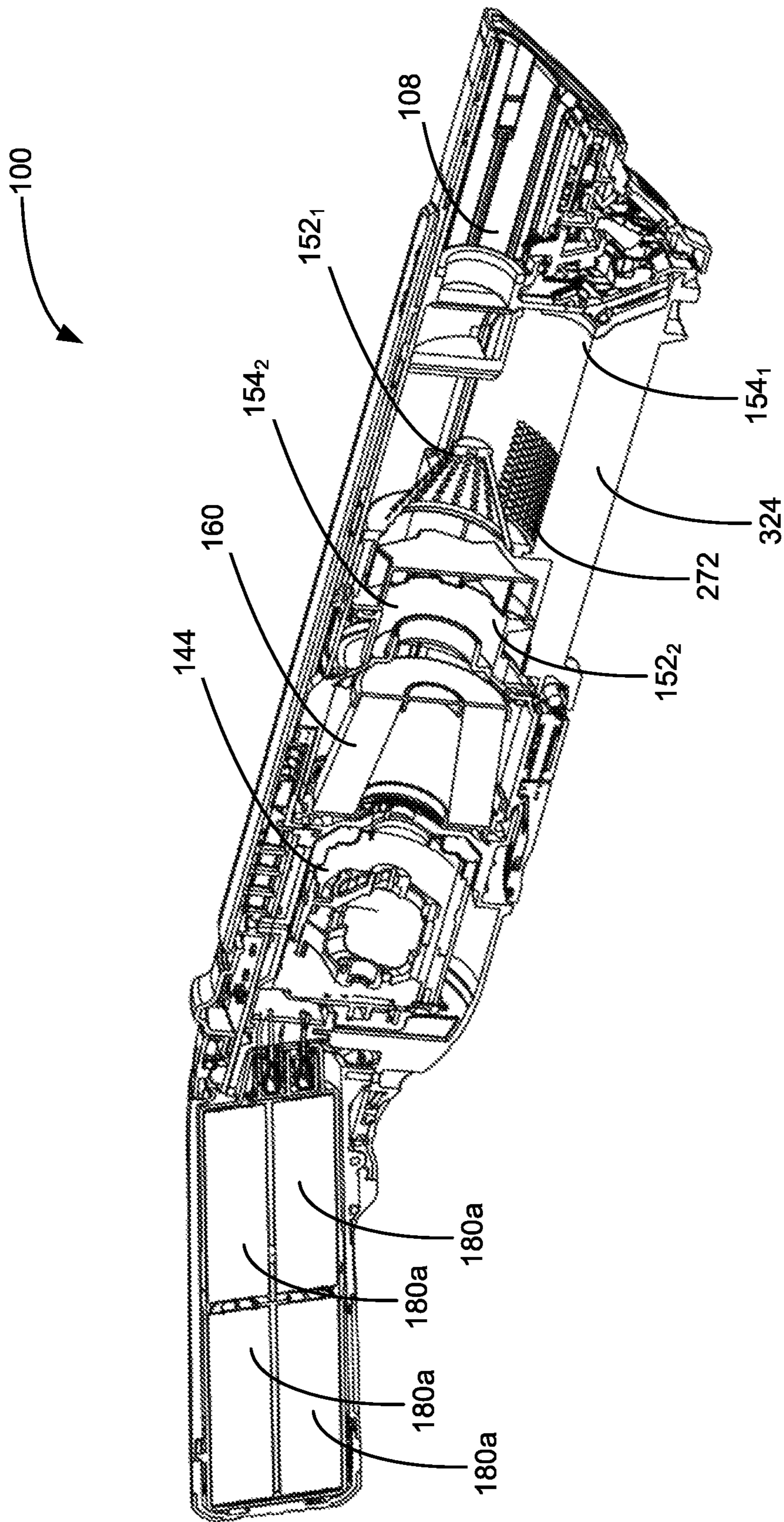


**FIG. 75**

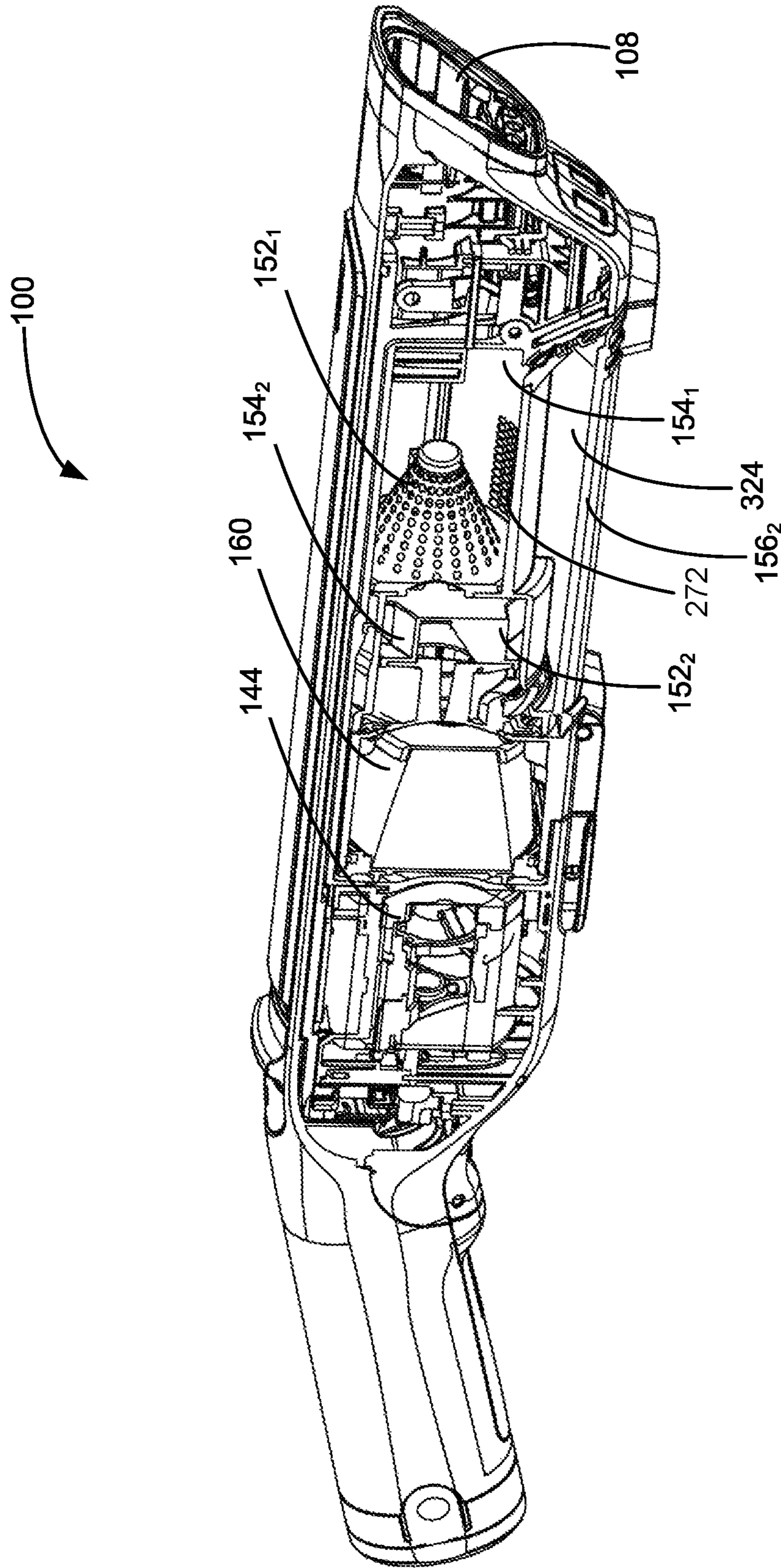


**FIG. 76**

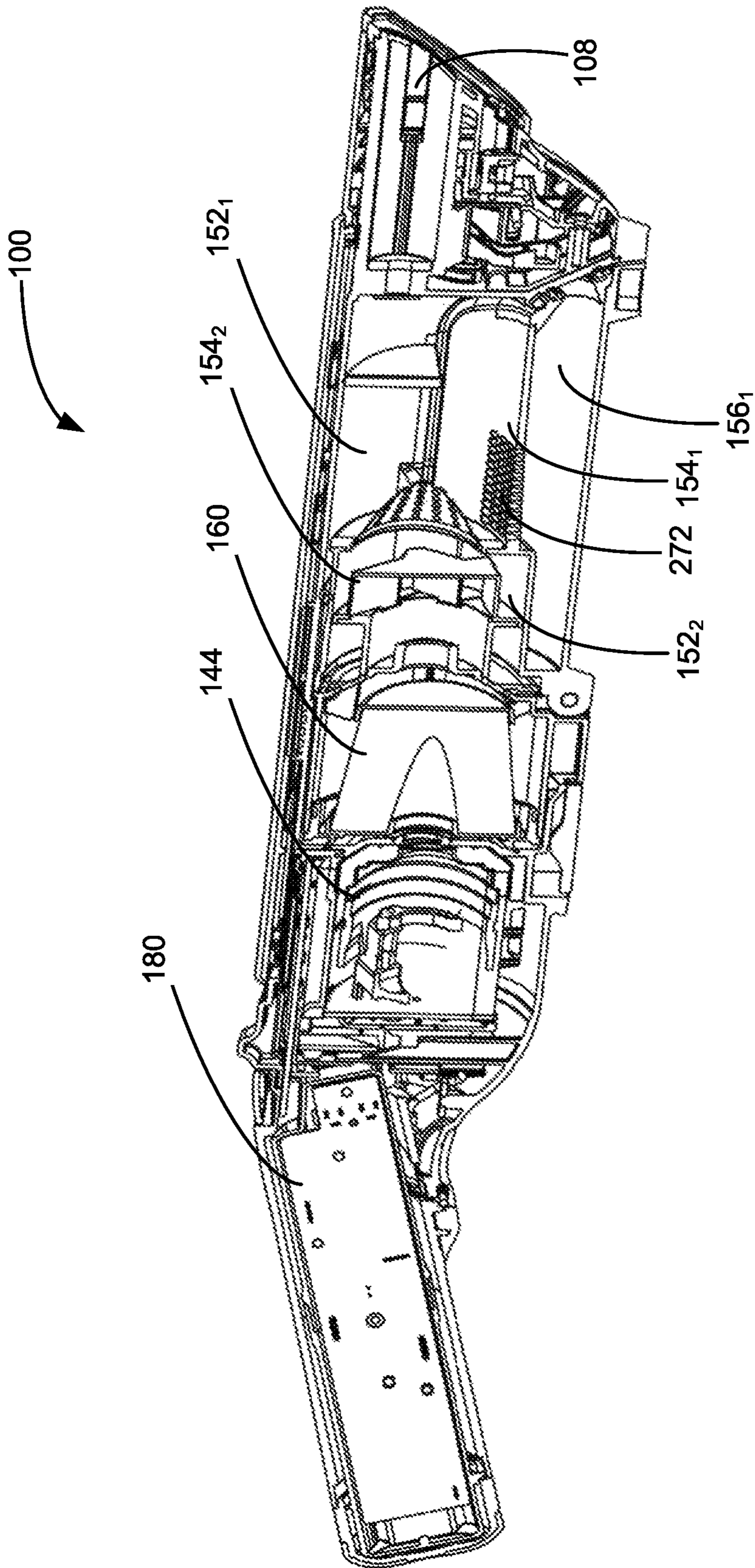




**FIG. 77**



**FIG. 78**



**FIG. 79**

1

**CYCLONIC AIR TREATMENT MEMBER  
AND SURFACE CLEANING APPARATUS  
INCLUDING THE SAME**

CROSS-REFERENCE TO RELATED  
APPLICATION

This application is a continuation-in-part of U.S. patent application Ser. No. 16/529,430, filed Aug. 1, 2019, which is a continuation-in-part of U.S. patent application Ser. No. 16/101,770, filed Aug. 13, 2018; and is also a continuation-in-part of U.S. patent application Ser. No. 16/201,649, filed Nov. 27, 2018, which itself claims priority to U.S. Provisional Patent Application No. 62/734,603, filed Sep. 21, 2018, herein incorporated by reference for all purposes.

FIELD

This application relates to the field of cyclonic air treatment members and surface cleaning apparatus including the same.

INTRODUCTION

The following is not an admission that anything discussed below is part of the prior art or part of the common general knowledge of a person skilled in the art.

Various types of surface cleaning apparatus are known, including upright surface cleaning apparatus, canister surface cleaning apparatus, stick surface cleaning apparatus, central vacuum systems, and hand carryable surface cleaning apparatus such as hand vacuums. Further, various designs for cyclonic hand vacuum cleaners, including battery operated cyclonic hand vacuum cleaners, are known in the art.

Surface cleaning apparatus are known which utilize one or more cyclones. A cyclone has a dirt collection region. The dirt collection region may be internal of the cyclone chamber (e.g., the dirt collection region may be a lower end of the cyclone chamber. Alternately, the dirt collection region may be a separate dirt collection chamber that is external to the cyclone chamber and in communication with the cyclone chamber via a dirt outlet. The dirt out may be a slot formed in the sidewall of a cyclone chamber or a gap provided between the end of the cyclone wall and an end of the cyclone chamber.

SUMMARY

In accordance with one aspect of this disclosure, a cyclone chamber is provided with a dirt collection chamber that is in communication with the cyclone chamber by an axially extending dirt outlet. The dirt outlet may have a length dimension in the axial longitudinal direction of the cyclone chamber that is greater than its width dimension in the circumferential direction of the cyclone chamber. For example, the length of the dirt outlet may be 2, 4, 6, 8 or 10 times or more the width of the dirt outlet (i.e., the width in the direction around the perimeter of the cyclone sidewall in a plane transverse to the cyclone axis). An advantage of this design is that, as the air rotates in the cyclone chamber and dirt is disentrained, the disentrained dirt may be deposited into a dirt collection chamber without the disentrained dirt having to be conveyed along the cyclone sidewall to a dirt outlet at an axial end of the cyclone chamber. Accordingly, the tendency of dirt to be re-entrained in the air rotating in the cyclone chamber may be reduced.

2

In accordance with this aspect, there is provided a surface cleaning apparatus comprising an air flow path extending from a dirty air inlet to a clean air outlet with a cyclone and a suction motor positioned in the air flow path, the cyclone comprising:

- (a) a cyclone chamber having a cyclone sidewall, a longitudinally extending cyclone axis of rotation, a cyclone first end, a cyclone second end spaced apart in a longitudinal axial direction from the cyclone first end, a cyclone air inlet proximate the cyclone first end, a cyclone air outlet located at the cyclone second end and a dirt outlet, wherein the dirt outlet has a length in the axial direction and a width in a circumferential direction and the length is greater than the width; and,
- (b) a dirt collection chamber external to the cyclone chamber and in communication with the cyclone chamber via the dirt outlet.

In any embodiment, the length may be at least twice as long as the width.

In any embodiment, the length may be at least four times as long as the width.

In any embodiment, the dirt outlet may extend from a position proximate the cyclone first end towards the cyclone second end.

In any embodiment, the dirt outlet may extend to a position proximate the cyclone second end.

In any embodiment, the cyclone air inlet may be a tangential air inlet terminating at an inlet port provided on the cyclone chamber sidewall.

In any embodiment, the cyclone front end may be openable wherein, when the cyclone front end is moved to an open position, the cyclone chamber and the dirt collection chamber may each be opened.

In any embodiment, the surface cleaning apparatus may further comprise a dirt outlet insert member which is removably receivable in a portion of the dirt outlet adjacent the cyclone first end and the dirt outlet insert member may be opened when the cyclone front end is moved to an open position.

In any embodiment, the surface cleaning apparatus may further comprise a screen member having an outlet end located at the cyclone second end and the screen member may extend to distal screen end located adjacent the cyclone first end.

In any embodiment, the distal end of the screen member may terminate 0.01-0.75 inches from the cyclone first end.

In any embodiment, the distal end of the screen member may terminate 0.05-0.375 inches from the cyclone first end.

In any embodiment, the cyclone air inlet may be a tangential inlet having a conduit portion interior the cyclone chamber and the dirt outlet may extend from a position proximate an axially inner side of the inlet conduit towards the cyclone second end.

In any embodiment, the dirt outlet may extend to a position proximate the cyclone second end.

In any embodiment, the dirt outlet may extend from a position 0.01-0.2 inches axially inwardly from the axially inner side of the inlet conduit towards the cyclone second end.

In any embodiment, the cyclone front end may be openable wherein, when the cyclone front end is moved to an open position, the cyclone chamber and the dirt collection chamber may each be opened.

In any embodiment, the surface cleaning apparatus may further comprise a screen member having an outlet end located at the cyclone second end and the screen member

3

may extend to distal screen end located adjacent the axially inner side of the inlet conduit.

In any embodiment, the surface cleaning apparatus may further comprise a dirt outlet insert member which is removably receivable in a portion of the dirt outlet adjacent the cyclone first end and the dirt outlet insert member may be opened when the cyclone front end is moved to an open position.

In accordance with another aspect of this disclosure, a cyclone chamber is provided with a dirt collection chamber that is in communication with the cyclone chamber by two or more dirt outlet regions. The two dirt outlet regions may be discrete outlets (i.e., each dirt outlet region may be a dirt outlet that is surrounded by, e.g., a portion of the sidewall of the cyclone chamber or a portion of the sidewall of the cyclone chamber and a portion of an end wall of the cyclone chamber) or they may be contiguous (e.g., they may be connected by a gap or slot formed in the cyclone chamber sidewall so as to form a single dirt outlet opening in, e.g., the cyclone chamber sidewall).

An advantage of this design is that dirt which is separated from the air swirling in the cyclone chamber prior to the swirling air reaching an end of the cyclone chamber opposed to the cyclone air inlet end (e.g., after the air has turned, for example, 1 or 2 times in the cyclone chamber) may be removed from the cyclone chamber by a first dirt outlet region and the remainder of the dirt may be separated in a second dirt outlet region that is located closer to or at the end of the cyclone chamber opposed to the cyclone air inlet end.

In accordance with this aspect, there is provided a cyclonic air treatment member comprising:

- (a) a cyclone having a cyclone sidewall, a cyclone first end, an opposed cyclone second end, a cyclone air inlet proximate the cyclone first end, a cyclone air outlet and a cyclone longitudinal axis extending from the cyclone first end to the cyclone second end, wherein a cyclone chamber is located between the cyclone first and second ends and the cyclone chamber has an outer perimeter which comprises the cyclone sidewall, wherein an air flow path extends from the cyclone air inlet to the cyclone air outlet: and,
- (b) a dirt collection chamber external to the cyclone chamber, the dirt collection chamber having first and second dirt outlet regions, each dirt outlet region extending around a portion of the perimeter of the cyclone chamber, wherein the second dirt outlet region is positioned proximate the cyclone second end, and the first dirt outlet region is positioned toward the cyclone first end relative to the second dirt outlet region.

In any embodiment, the first dirt outlet region may be longitudinally spaced apart from and discrete from the second dirt outlet region.

In any embodiment, the second dirt outlet region may be longitudinally spaced apart from and contiguous with the first dirt outlet region.

In any embodiment, the first dirt outlet region may be angularly offset about the outer perimeter of the cyclone chamber as compared to the second dirt outlet region.

In any embodiment, at least one of the first and second dirt outlet regions may comprise a slot extending angularly around a portion of the perimeter of the cyclone chamber.

In any embodiment, at least one of the first and second dirt outlet regions may comprise an array of 4 or more (e.g., 4, 5, 6, 7, 8, 9 or 10) apertures formed in the cyclone sidewall.

In any embodiment, the first dirt outlet region may comprise a slot formed in the cyclone sidewall, and the second dirt outlet region comprises an array of 4 or more

4

(e.g., 4, 5, 6, 7, 8, 9 or 10) apertures formed in the cyclone sidewall and positioned adjacent the first dirt outlet region between the cyclone first end and the first dirt outlet region.

In any embodiment, each of the first and second dirt outlet regions may have a long dimension, and the long dimension of the first dirt outlet region is oriented generally transverse to the long dimension of the second dirt outlet region.

In any embodiment, the air flow path may include a cyclonic path portion that extends cyclonically from the cyclone air inlet toward the cyclone second end, and at least one of the dirt outlet regions may have a long dimension that is aligned with the cyclonic path portion. At least 75% of the first dirt outlet region may extend along a portion of the cyclonic path portion. Alternately, the first dirt outlet region may extend along the cyclonic path from an upstream outlet end of the first dirt outlet region to a downstream outlet end of the first dirt outlet region.

In any embodiment, the downstream outlet end of the first dirt outlet region may be positioned towards the cyclone second end relative to the upstream outlet end of the first dirt outlet region.

In any embodiment, both of the upstream outlet end of the first dirt outlet region and the downstream outlet end of the first dirt outlet region may be located along a portion of the cyclonic path portion.

In any embodiment, the second dirt outlet region may have a long dimension having a radial projection that is aligned perpendicularly to the cyclone axis. Alternately or in addition, the first dirt outlet region may have a long dimension having a radial projection that is aligned parallel to the cyclone axis.

In any embodiment, the second dirt outlet region may be bordered by the cyclone second end.

In any embodiment, the cyclone may further comprise a third dirt outlet region to the dirt collection chamber, the third dirt outlet region is formed in the cyclone sidewall, and is oriented transverse to the first and second dirt outlet regions. The first, second, and third dirt outlet regions may be contiguous. Alternately, one, two or all three may be discrete or one may be discrete and two may be contiguous.

In any embodiment, the cyclone air outlet may be at the cyclone second end. Alternately, the cyclone air outlet may be at the cyclone first end.

In accordance with another aspect, a plurality of discrete dirt outlet regions (slots) are provided. The discrete outlet regions may provide enable enhanced dirt separation by the cyclone without increasing the backpressure in the cyclone chamber.

In accordance with this aspect, there is provided a cyclonic air treatment member comprising:

- (a) a cyclone having a cyclone sidewall, a cyclone first end, an opposed cyclone second end, a cyclone air inlet proximate the cyclone first end, a cyclone air outlet, a dirt outlet and a cyclone longitudinal axis extending from the cyclone first end to the cyclone second end, wherein a cyclone chamber is located between the cyclone first and second ends and the cyclone chamber has an outer perimeter which comprises the cyclone sidewall: and,
- (b) a dirt collection chamber external to the cyclone chamber and in communication with the cyclone chamber via the dirt outlet, wherein the dirt outlet comprises a plurality of discrete dirt outlet regions, each of which extends at an angle to the cyclone longitudinal axis.

## 5

In any embodiment, the plurality of dirt outlet regions may extend perpendicular  $\pm 15, 20, 25$  or  $30^\circ$  to the cyclone longitudinal axis.

In any embodiment, the plurality of dirt outlet regions may extend generally perpendicular to the cyclone longitudinal axis.

In any embodiment, the plurality of dirt outlet regions may comprise a plurality of outlet slots that are arranged side by side along at least a portion of an axial length of the cyclone.

In any embodiment, a first dirt outlet region may be positioned proximate the cyclone second end, and a remainder of the plurality of dirt outlet regions may be positioned axially inward of the first dirt outlet region towards the cyclone first end.

In any embodiment, the cyclone air outlet may be located at the cyclone second end.

In any embodiment, the cyclone air outlet may comprise a solid portion at the cyclone second end and an air permeable portion axially inward thereof and the dirt outlet regions may be positioned only in a portion of the cyclone sidewall that is radially outward of the solid conduit.

In any embodiment, the cyclone air outlet may comprise a solid conduit portion at the cyclone second end and an air permeable portion axially inward thereof and the dirt outlet regions may be positioned in a portion of the cyclone sidewall that is radially outward of the solid conduit portion and air permeable portion.

In any embodiment, the dirt outlet may comprise at least three, five, seven or nine dirt outlet regions.

In any embodiment, the dirt outlet regions may be axially spaced apart from each other.

In any embodiment, the cyclone air inlet may be a tangential inlet having a conduit portion interior the cyclone chamber and the plurality of dirt outlet regions may extend from the cyclone second end to a position axially inward of an axially inner side of the inlet conduit. Optionally, the plurality of dirt outlet regions may extend to a position proximate the axially inner side of the inlet conduit towards the cyclone second end.

In any embodiment, the cyclone air inlet may terminate at an inlet port provided on the cyclone chamber sidewall and the plurality of dirt outlet regions may extend from the cyclone second end towards the cyclone first end. Optionally, the plurality of dirt outlet regions may extend to a position proximate the cyclone first end.

In any embodiment, at least one of the dirt outlet regions may have first and second axially spaced apart sides wherein at least one of the sides is convex or concave.

In any embodiment, at least some of the dirt outlet regions may be axially evenly spaced apart.

In any embodiment, at least some of the dirt outlet regions may be axially spaced apart by varying amounts.

In any embodiment, the dirt outlet regions may have an axial dirt outlet width and the axial dirt outlet width of the dirt outlet regions may decrease from a forward location of the cyclone at which the dirt outlet regions commence to a rear location of the cyclone at which the dirt outlet regions terminate.

In any embodiment, the dirt outlet regions may be spaced apart by an axial distance and the axial distance may decrease from a forward location of the cyclone at which the dirt outlet regions commence to a rear location of the cyclone at which the dirt outlet regions terminate.

In accordance with another aspect of this disclosure, a surface cleaning apparatus is provided with a cyclone chamber having a dirt collection chamber that is in communi-

## 6

tion with the cyclone chamber by a dirt outlet that includes a plurality of perforations or apertures.

An advantage of this design is that the size of the apertures may reduce backpressure caused by air leaving the cyclone chamber to enter the dirt collection chamber. Another possible advantage is that dirt particles may pass through the apertures into the dirt collection chamber as they are disentrained from the air, while large debris may remain in the cyclone chamber, thereby allowing the cyclone chamber to be used as a collection chamber for large debris, increasing the dirt collection capacity of the surface cleaning apparatus without increasing the size of the surface cleaning apparatus. This is particularly advantageous for a hand held vacuum cleaner.

In accordance with this aspect, there is provided a surface cleaning apparatus comprising an air flow path extending from a dirty air inlet to a clean air outlet with a first cyclonic cleaning stage and a suction motor positioned in the air flow path, the first cyclonic cleaning stage comprising a first cyclone chamber and a first dirt collection chamber external to the first cyclone chamber, the first cyclone chamber having a cyclone first end, an opposed cyclone second end, a cyclone sidewall extending between the cyclone first end and the cyclone second end, a cyclone air inlet, a cyclone air outlet, a cyclone dirt outlet in communication with the first dirt collection chamber and a cyclone longitudinal axis extending from the cyclone first end to the cyclone second end, wherein the dirt outlet comprises a plurality of apertures.

In any embodiment, the plurality of apertures may comprise more than 10 apertures.

In any embodiment, the plurality of apertures may comprise more than 20 apertures.

In any embodiment, the apertures may have a width of 0.10 inches to 0.20 inches.

In any embodiment, the apertures may have a width of 0.010 inches to 0.10 inches.

In any embodiment, the apertures may be provided at a cyclone air outlet end of the first cyclone chamber.

In any embodiment, the cyclone air outlet end may be the cyclone second end and the cyclone air inlet may be provided at the cyclone first end.

In any embodiment, the surface cleaning apparatus may be a hand vacuum cleaner having an upper end and a lower end, the upper end may have the dirty air inlet and, when the hand vacuum cleaner is oriented with the upper end above the lower end, the apertures may be provided in a lower portion of the cyclone sidewall.

In any embodiment, the cyclonic cleaning stage may comprise a stationary portion and an openable portion, the openable portion may be part of the lower end of the hand vacuum cleaner and may comprise a portion of the cyclone sidewall and the openable portion may be moveably mounted by a mount between a closed position in which the first cyclone chamber and the first dirt collection chamber are closed and an open position in which the first cyclone chamber and the first dirt collection chamber are open and the apertures may be provided in the openable portion.

In any embodiment, when the hand vacuum cleaner may be oriented with the upper end above the lower end, the first dirt collection chamber may underlie the first cyclone chamber.

In any embodiment, the first cyclone chamber may have a first lateral side that extends radially outwardly from the cyclone longitudinal axis in a first direction and a second lateral side that extends radially outwardly from the cyclone longitudinal axis in a second direction that is opposed to the

first direction and the apertures may be provided only on the first lateral side of the first cyclone chamber.

In any embodiment, the surface cleaning apparatus may further comprise a second cyclonic cleaning stage downstream from the first cyclonic cleaning stage, the second cyclonic cleaning stage may have a dirt collection region wherein, when the hand vacuum cleaner is oriented with the upper end above the lower end, the first dirt collection chamber and the dirt collection region may each underlie the first cyclone chamber.

In any embodiment, the second cyclonic cleaning stage may comprise a second cyclone chamber and a second dirt collection chamber external to the second cyclone chamber and the second dirt collection chamber may comprise the dirt collection region.

In any embodiment, the first cyclone chamber may have a first lateral side that extends radially outwardly from the cyclone longitudinal axis in a first direction and a second lateral side that extends radially outwardly from the cyclone longitudinal axis in a second direction that is opposed to the first direction and the apertures may be provided only on the first lateral side of the first cyclone chamber, the first dirt collection chamber may be located on the first lateral side and the dirt collection region may be located on the second lateral side.

In accordance with another aspect of this disclosure, there is provided a surface cleaning apparatus having a first air treatment stage having a first air treatment chamber and a first dirt collection chamber, and a second air treatment stage having a second dirt collection chamber. The first dirt collection chamber and the second dirt collection chamber each underlie the first air treatment chamber.

An advantage of this design is that by positioning the dirt collection chambers beneath the first air treatment chamber, the first and second dirt collection chambers may be emptyable concurrently, and optionally with emptying the first air treatment chamber. A further advantage is that the size of the surface cleaning apparatus may be reduced since access to the second air treatment stage is not necessary to empty the surface cleaning apparatus.

In accordance with this aspect, there is provided a surface cleaning apparatus comprising:

- a) a front end, a rear end, and first and second laterally opposed sides, each laterally opposed side extends in a forward/rearward direction;
- b) an air flow path extending from a dirty air inlet provided at the front end to a clean air outlet with a suction motor positioned in the air flow path;
- c) a first air treatment stage positioned in the air flow path downstream from the dirty air inlet, the first air treatment stage comprising a first air treatment chamber and a first dirt collection chamber external to the first air treatment chamber; and,
- d) a second air treatment stage positioned in the air flow path downstream from the first air treatment stage, the second air treatment stage comprising a second air treatment chamber and a second dirt collection chamber external to the second air treatment chamber, wherein the first dirt collection chamber is provided on the first lateral side and underlies the first air treatment chamber and the second dirt collection chamber is provided on the second lateral side and underlies the first air treatment chamber.

In any embodiment, the first air treatment chamber may have a dirt outlet in communication with the first dirt collection chamber and the dirt outlet may comprise a plurality of apertures.

In any embodiment, the plurality of apertures may comprise more than 10 apertures.

In any embodiment, the plurality of apertures may comprise more than 20 apertures.

In any embodiment, the apertures may have a width of 0.10 inches to 0.20 inches.

In any embodiment, the apertures may have a width of 0.010 inches to 0.10 inches. It will be appreciated that a surface cleaning apparatus may comprise any one or more aspects set out herein and may use any one or more features of one or more of the aspects disclosed herein.

#### BRIEF DESCRIPTION OF THE DRAWINGS

For a better understanding of the described embodiments and to show more clearly how they may be carried into effect, reference will now be made, by way of example, to the accompanying drawings in which:

FIG. 1 is a perspective view of a surface cleaning apparatus in accordance with an embodiment;

FIG. 2 is a cross-sectional view taken along line 2-2 in FIG. 1, in accordance with an embodiment;

FIG. 3 is a perspective view of an air treatment member of the apparatus of FIG. 1 with a front wall and air outlet passage omitted, in accordance with an embodiment;

FIG. 4 is a perspective view of the air treatment member of the apparatus of FIG. 1, sectioned along line 2-2 in FIG. 1, and with the front wall and air outlet passage omitted, in accordance with the embodiment of FIG. 3;

FIG. 5 is a perspective view of the air treatment member of the apparatus of FIG. 1, sectioned along line 5-5 in FIG. 1, and with the front wall and air outlet passage omitted, in accordance with the embodiment of FIG. 3;

FIG. 6 is a perspective view of an alternate embodiment of the air treatment member of the apparatus of FIG. 1 with the front wall and air outlet passage omitted, in accordance with another embodiment;

FIG. 7 is a perspective view of the alternate air treatment member of FIG. 6, sectioned along line 2-2 in FIG. 1, and with the front wall and air outlet passage omitted, in accordance with the embodiment of FIG. 6;

FIGS. 8-21 are perspective views of the air treatment member of the apparatus of FIG. 1, sectioned along line 5-5 in FIG. 1, and with the front wall and air outlet passage omitted, in accordance with various embodiments;

FIG. 22 is a cross-sectional view taken along line 2-2 in FIG. 1, in accordance with another embodiment;

FIG. 23 is a cross-sectional view taken along line 2-2 in FIG. 1, in accordance with another embodiment;

FIG. 24 is a perspective view of an upright surface cleaning apparatus in accordance with an embodiment;

FIG. 25 is a cross-sectional view taken along line 25-25 in FIG. 24, in accordance with another embodiment;

FIG. 26 is a perspective view of the surface cleaning apparatus of claim 1 sectioned along line 2-2, in accordance with another embodiment;

FIG. 27 is a perspective view of the surface cleaning apparatus of claim 1 sectioned along line 27-27, in accordance with another embodiment;

FIG. 28 is a perspective view of a surface cleaning apparatus in accordance with another embodiment;

FIG. 29 is a perspective view of an air treatment member of the apparatus of FIG. 28, sectioned along line 29-29 in FIG. 28, in accordance with an embodiment;

FIG. 30 is a cross-sectional view of the air treatment member of FIG. 29, sectioned along line 29-29 in FIG. 28, in accordance with the embodiment of FIG. 29;





## 11

FIG. 78 is a cross-sectional perspective view of the surface cleaning apparatus of FIG. 72, sectioned along line 78-78 in FIG. 76, with the openable portion closed; and,

FIG. 79 is a cross-sectional perspective view of the surface cleaning apparatus of FIG. 72, sectioned along line 79-79 in FIG. 76, with the openable portion closed.

## DESCRIPTION OF EXAMPLE EMBODIMENTS

Numerous embodiments are described in this application, and are presented for illustrative purposes only. The described embodiments are not intended to be limiting in any sense. The invention is widely applicable to numerous embodiments, as is readily apparent from the disclosure herein. Those skilled in the art will recognize that the present invention may be practiced with modification and alteration without departing from the teachings disclosed herein. Although particular features of the present invention may be described with reference to one or more particular embodiments or figures, it should be understood that such features are not limited to usage in the one or more particular embodiments or figures with reference to which they are described.

The terms “an embodiment,” “embodiment,” “embodiments,” “the embodiment,” “the embodiments,” “one or more embodiments,” “some embodiments,” and “one embodiment” mean “one or more (but not all) embodiments of the present invention(s),” unless expressly specified otherwise.

The terms “including,” “comprising” and variations thereof mean “including but not limited to,” unless expressly specified otherwise. A listing of items does not imply that any or all of the items are mutually exclusive, unless expressly specified otherwise. The terms “a,” “an” and “the” mean “one or more,” unless expressly specified otherwise.

As used herein and in the claims, two or more parts are said to be “coupled”, “connected”, “attached”, “joined”, “affixed”, or “fastened” where the parts are joined or operate together either directly or indirectly (i.e., through one or more intermediate parts), so long as a link occurs. As used herein and in the claims, two or more parts are said to be “directly coupled”, “directly connected”, “directly attached”, “directly joined”, “directly affixed”, or “directly fastened” where the parts are connected in physical contact with each other. As used herein, two or more parts are said to be “rigidly coupled”, “rigidly connected”, “rigidly attached”, “rigidly joined”, “rigidly affixed”, or “rigidly fastened” where the parts are coupled so as to move as one while maintaining a constant orientation relative to each other. None of the terms “coupled”, “connected”, “attached”, “joined”, “affixed”, and “fastened” distinguish the manner in which two or more parts are joined together.

Further, although method steps may be described (in the disclosure and/or in the claims) in a sequential order, such methods may be configured to work in alternate orders. In other words, any sequence or order of steps that may be described does not necessarily indicate a requirement that the steps be performed in that order. The steps of methods described herein may be performed in any order that is practical. Further, some steps may be performed simultaneously.

As used herein and in the claims, two elements are said to be “parallel” where those elements are parallel and spaced apart, or where those elements are collinear.

Some elements herein may be identified by a part number, which is composed of a base number followed by an alphabetical or subscript-numerical suffix (e.g. 112a, or

## 12

112<sub>1</sub>). Multiple elements herein may be identified by part numbers that share a base number in common and that differ by their suffixes (e.g. 112<sub>1</sub>, 112<sub>2</sub>, and 112<sub>3</sub>). All elements with a common base number may be referred to collectively or generically using the base number without a suffix (e.g. 112).

## General Description of a Hand Vacuum Cleaner

Referring to FIGS. 1-2, an exemplary embodiment of a surface cleaning apparatus is shown generally as 100. The following is a general discussion of apparatus 100, which provides a basis for understanding several of the features that are discussed herein. As discussed subsequently, each of the features may be used individually or in any particular combination or sub-combination in this or in other embodiments disclosed herein.

Embodiments described herein include an improved cyclonic air treatment member 116, and a surface cleaning apparatus 100 including the same. Surface cleaning apparatus 100 may be any type of surface cleaning apparatus, including for example a hand vacuum cleaner as shown (see also FIG. 28), a stick vacuum cleaner, an upright vacuum cleaner (100 in FIG. 24), a canister vacuum cleaner, an extractor, or a wet/dry type vacuum cleaner.

In FIGS. 1-2 and 28, surface cleaning apparatus 100 is illustrated as a hand vacuum cleaner, which may also be referred to also as a “handvac” or “hand-held vacuum cleaner”. As used herein, a hand vacuum cleaner is a vacuum cleaner that can be operated to clean a surface generally one-handedly. That is, the entire weight of the vacuum may be held by the same one hand used to direct a dirty air inlet of the vacuum cleaner with respect to a surface to be cleaned. For example, handle 104 and dirty air inlet 108 may be rigidly coupled to each other (directly or indirectly), such as being integrally formed or separately molded and then non-removably secured together (e.g. adhesive or welding), so as to move as one while maintaining a constant orientation relative to each other. This is to be contrasted with canister and upright vacuum cleaners, whose weight is typically supported by a surface (e.g. a floor) during use. When a canister vacuum cleaner is operated, or when an upright vacuum cleaner is operated in a ‘lift-away’ configuration, a second hand is typically required to direct the dirty air inlet at the end of a flexible hose.

Still referring to FIGS. 1-2 and 28, surface cleaning apparatus 100 includes a main body or a handvac body 112 having an air treatment member 116 (which may be permanently affixed to the main body or may be removable in part or in whole therefrom for emptying), a dirty air inlet 108, a clean air outlet 120, and an air flow path 124 extending between the dirty air inlet 108 and the clean air outlet 120.

Surface cleaning apparatus 100 has a front end 128, a rear end 132, an upper end (also referred to as the top) 136, and a lower end (also referred to as the bottom) 140. In the embodiment shown, dirty air inlet 108 is at an upper portion of apparatus front end 128 and clean air outlet 120 is at a rearward portion of apparatus 100 at apparatus rear end 132. It will be appreciated that dirty air inlet 108 and clean air outlet 120 may be positioned in different locations of apparatus 100.

A suction motor 144 is provided to generate vacuum suction through air flow path 124, and is positioned within a motor housing 148. Suction motor 144 may be a fan-motor assembly including an electric motor and impeller blade(s). In the illustrated embodiment, suction motor 144 is positioned in the air flow path 124 downstream of air treatment member 116. In this configuration, suction motor 144 may be referred to as a “clean air motor”. Alternatively, suction

## 13

motor **144** may be positioned upstream of air treatment member **116**, and referred to as a “dirty air motor”.

Air treatment member **116** is configured to remove particles of dirt and other debris from the air flow. In the illustrated example, air treatment member **116** includes a cyclone assembly (also referred to as a “cyclone bin assembly”) having a single cyclonic cleaning stage with a single cyclone **152** and a dirt collection chamber **156** (also referred to as a “dirt collection region”, “dirt collection bin”, “dirt bin”, or “dirt chamber”). Cyclone **152** has a cyclone chamber **154**. Dirt collection chamber **156** may be external to the cyclone chamber **154** (i.e. dirt collection chamber **156** may have a discrete volume from that of cyclone chamber **154**). Cyclone **152** and dirt collection chamber **156** may be of any configuration suitable for separating dirt from an air stream and collecting the separated dirt respectively, and may be in communication dirt outlet(s) of the cyclone chamber.

In alternate embodiments, air treatment member **116** may include a cyclone assembly having two or more cyclonic cleaning stages arranged in series with each other. Each cyclonic cleaning stage may include one or more cyclones arranged in parallel with each other and one or more dirt collection chambers, of any suitable configuration. The dirt collection chamber(s) may be external to the cyclone chambers of the cyclones. Each cyclone may have its own dirt collection chamber or two or more cyclones fluidically connected in parallel may have a single common dirt collection chamber.

Referring to FIG. 2, hand vacuum cleaner **100** may include a pre-motor filter **160** provided in the air flow path **124** downstream of air treatment member **116** and upstream of suction motor **144**. Pre-motor filter **160** may be formed from any suitable physical, porous filter media. For example, pre-motor filter **160** may be one or more of a foam filter, felt filter, HEPA filter, or other physical filter media. In some embodiments, pre-motor filter **160** may include an electrostatic filter, or the like. As shown, pre-motor filter **160** may be located in a pre-motor filter housing **164** that is external to the air treatment member **116**.

In the illustrated embodiments, dirty air inlet **108** is the inlet end **168** of an air inlet conduit **172**. Optionally, inlet end **168** of air inlet conduit **172** can be used as a nozzle to directly clean a surface. Alternatively, or in addition to functioning as a nozzle, air inlet conduit **172** may be connected (e.g. directly connected) to the downstream end of any suitable accessory tool such as a rigid air flow conduit (e.g., an above floor cleaning wand), a crevice tool, a mini brush, and the like. As shown, dirty air inlet **108** may be positioned forward of air treatment member **116**, although this need not be the case.

In the embodiment of FIGS. 2 and 28, the air treatment member **116** comprises a cyclone **152**, the air treatment air inlet is a cyclone air inlet **184**, and the air treatment member air outlet is a cyclone air outlet **188**. Accordingly, in operation, after activating suction motor **144**, dirty air enters apparatus **100** through dirty air inlet **108** and is directed along air inlet conduit **172** to the cyclone air inlet **184**. As shown, cyclone air inlet **184** may direct the dirty air flow to enter cyclone chamber **154** in a tangential direction so as to promote cyclonic action. Dirt particles and other debris may be disentrained (i.e. separated) from the dirty air flow as the dirty air flow travels from cyclone air inlet **184** to cyclone air outlet **188**. The disentrained dirt particles and debris may discharge from cyclone chamber **154** through a dirt outlet **190** into dirt collection chamber **156** external to the cyclone

## 14

chamber **154**, where the dirt particles and debris may be collected and stored until dirt collection chamber **156** is emptied.

Air exiting cyclone chamber **154** may pass through an outlet passage **192** located upstream of cyclone air outlet **188**. Cyclone chamber outlet passage **192** may also act as a vortex finder to promote cyclonic flow within cyclone chamber **154**. In some embodiments, cyclone outlet passage **192** may include an air permeable portion **197** (which may be referred to as a screen or shroud **197**, e.g. a fine mesh screen) in the air flow path **124** to remove large dirt particles and debris, such as hair, remaining in the exiting air flow. As exemplified in FIG. 50, the cyclone air outlet **188** may comprise a conduit portion **189** which is solid (air impermeable) and an axially inward screen or shroud **197**.

From cyclone air outlet **188**, the air flow may be directed into pre-motor filter housing **164** at an upstream side **196** of pre-motor filter **160**. The air flow may pass through pre-motor filter **160**, and then exit through pre-motor filter chamber air outlet **198** into motor housing **148**. At motor housing **148**, the clean air flow may be drawn into suction motor **144** and then discharged from apparatus **100** through clean air outlet **120**. Prior to exiting the clean air outlet **120**, the treated air may pass through a post-motor filter **176**, which may be one or more layers of filter media.

Power may be supplied to suction motor **144** and other electrical components of apparatus **100** from an onboard energy storage member, which may include, for example, one or more batteries **180a** or other energy storage device. In the illustrated embodiment, apparatus **100** includes a battery pack **180**. Battery pack **180** may be permanently connected to apparatus **100** and rechargeable in-situ, or removable from apparatus **100**. In the example shown, battery pack **180** is located between handle **104** and air treatment member **116**. Alternatively, or in addition to battery pack **180**, power may be supplied to apparatus **100** by an electrical cord (not shown) connected to apparatus **100** that can be electrically connected to mains power by at a standard wall electrical outlet.

Cyclonic Air Treatment Member with Two or More Dirt Outlets Extending Angularly Around the Cyclone Chamber Sidewall

Embodiments herein relate to an improved cyclonic air treatment member that may have two or more dirt outlets, which extend around a portion of the perimeter of the cyclone chamber sidewall. The features in this section may be used by themselves in any surface cleaning apparatus or in any combination or sub-combination with any other feature or features described herein.

Within a cyclone, dirt is disentrained from a dirt laden air flow by directing the air flow along a cyclonic path. The cyclonic flow direction imparts radially outward forces upon dirt particles in the air flow, whereby the dirt particles are separated from the air flow and ultimately, e.g., ride against the cyclone sidewall. Dirt moved against the cyclone sidewall may exit from the cyclone chamber to a dirt collection chamber through a dirt outlet.

The ability of a cyclonic flow to separate dirt particles depends in part on the radial acceleration experienced by the dirt particles as a result of their cyclonic velocity through the cyclone. However, the cyclonic particle velocity may slow between the cyclone air inlet and air outlet. Below a threshold cyclonic particle velocity, the separation efficiency (i.e. the percentage of dirt particles separated from the dirty air flow by the cyclone) may be substantially reduced. When a vacuum cleaner operates at a high air flow rate (e.g. a ‘high power mode’ in a handvac), the cyclonic particle velocity

between the cyclone air inlet and air outlet may remain well above such threshold velocity. However, when a vacuum cleaner operates at a low air flow rate (e.g. a 'low power mode' in a handvac), the cyclonic particle velocity may fall below the threshold velocity at some point between the cyclone air inlet and air outlet. In such a case, some of the dirt particles that have already been disentrained may be reintrained.

Embodiments herein relate to an improved cyclone having a dirt outlet that comprises a plurality of dirt outlet regions. A first dirt outlet region may be positioned closer, along the cyclonic air flow path, to the cyclone air inlet. The dirt outlet may have at least one additional dirt outlet region that may be positioned closer, along the cyclonic air flow path, to the cyclone air inlet. The additional dirt outlet region may be positioned at a location at which the cyclonic particle velocity may still be high enough (e.g. above the threshold velocity) to provide a targeted separation efficiency, even when operating at a lower air flow rate. Thus, the additional dirt outlet may permit the apparatus to optionally operate at a lower air flow rate with less loss of separation efficiency, all else being equal. For a handvac, this may mitigate the loss of separation efficiency when operating in a 'low power mode', which otherwise has an advantage of consuming less power thereby providing a longer run-time on a single charge.

Referring to FIGS. 2-4, cyclone 152 includes a cyclone sidewall 202 that, as exemplified, extends along a cyclone longitudinal axis 204 between a cyclone first end 206 and a cyclone second end 208. Accordingly, cyclone chamber 154 is bounded by cyclone sidewall 202 and cyclone first and second ends 206, 208. Cyclone 152 includes a tangential air inlet 184, although any air inlet may be used. As shown, air inlet 184 may be located proximate cyclone first end 206, although the cyclone air inlet may be provided at other locations. Cyclone also includes an air outlet 188. Cyclone air outlet 188 may be located proximate cyclone second end 208, such as in the illustrated uniflow cyclone configuration, or it may be located at cyclone first end 206 (see, for example FIGS. 24-25). Apparatus air flow path 124 includes a cyclone air flow path 212, which extends from cyclone air inlet 184 to cyclone air outlet 188.

Referring to FIGS. 3-4, cyclone 152 may include first and second dirt outlet regions 190<sub>1</sub> and 190<sub>2</sub>. Second dirt outlet region 190<sub>2</sub> may be located proximate (e.g. at or closer to) cyclone second end 208. For example, second dirt outlet region 190<sub>2</sub> may be located at the cyclone second end 208 as exemplified in FIGS. 2 and 3. Second dirt outlet region 190<sub>2</sub> may be of any design known in the vacuum cleaner arts. For example, it may be a slot formed in the cyclone sidewall at the cyclone second end 208 as exemplified or it may be defined by a gap between the cyclone chamber sidewall and the second end wall 208 (e.g., it may be an annular opening at the end of the cyclone sidewall that faces the cyclone second end 208. First dirt outlet region 190<sub>1</sub> may be located axially or longitudinally towards cyclone first end 206 relative to second dirt outlet region 190<sub>2</sub>.

Referring to FIGS. 4-5, first dirt outlet region 190<sub>1</sub> may be provided anywhere in cyclone sidewall 202 having a longitudinal position between cyclone first end 206 and second dirt outlet 190<sub>2</sub>. For example, first dirt outlet region 190<sub>1</sub> may be longitudinally positioned between cyclone air inlet 184 and second dirt outlet 190<sub>2</sub>. This may allow dirt that enters cyclone 152 to exit through cyclone dirt outlet region 190<sub>1</sub> while that dirt has sufficient cyclonic velocity and before that dirt would have reached second dirt outlet region 190<sub>2</sub>.

In some embodiments, first dirt outlet region 190<sub>1</sub> may be aligned with a cyclonic portion of cyclone air flow path 212 (see for example FIG. 15). This allows separated dirt that is sliding on cyclone sidewall 202 as it is carried along a cyclonic portion of air flow path 212 to flow into first dirt outlet region 190<sub>1</sub>, through which the dirt can exit into dirt collection chamber 156. Accordingly, the alignment of first dirt outlet region 190<sub>1</sub> may permit the dirt outlet region 190<sub>1</sub> to better interact with dirt separated during an upstream portion of the cyclone air flow path 212. Even when operating at a low air flow rate, the upstream portion of flow path 212 may yet have sufficient dirt particle velocity to provide a high separation efficiency.

It will be appreciated that cyclone 152 may have more than first and second dirt outlet regions 190<sub>1</sub> and 190<sub>2</sub>. For example, as exemplified in FIGS. 50-52, three dirt outlet regions 190<sub>1</sub>, 190<sub>2</sub> and 190<sub>3</sub> may be provided. As exemplified in FIGS. 53-54, 57-59, 60-62 and 63-65 six dirt outlet regions 190<sub>1</sub>-190<sub>6</sub> may be provided. As exemplified in FIGS. 55-56, ten dirt outlet regions 190<sub>1</sub>-190<sub>10</sub> may be provided. As exemplified, the plurality of dirt outlet regions comprises a plurality of discrete outlet slots that are arranged side by side along a portion of, or all of, an axial length of the cyclone.

As exemplified in FIG. 50, the dirt outlet regions 190 may be positioned only in the portion of the cyclone chamber sidewall that is radially outward of the solid conduit portion 189 of the air outlet. Alternately, as exemplified in FIG. 53, the dirt outlet regions 190 may be positioned in the portion of the cyclone chamber sidewall that is radially outward of the solid conduit portion 189 and the screen/shroud 197 of the air outlet.

If a plurality of dirt outlet regions is provided, they may extend from the rear end of the cyclone 152 (cyclone second end 208) towards the front end (cyclone chamber first end 206) as exemplified in FIGS. 51 and 54, or to the front end of the cyclone as exemplified in FIG. 56. If the air inlet is provided internal of the cyclone 152, as exemplified in FIG. 55, then the dirt outlet regions 190 may terminate at or rearward of the downstream wall 183 of the air inlet conduit 129. Accordingly, the portion of the cyclone chamber sidewall extending forwardly of downstream wall 183 of the air inlet conduit 129 (section A in FIG. 55) may not have any dirt outlet regions 190.

Optionally, or in addition, if plurality of dirt outlet regions is provided, they may be evenly axially spaced apart as exemplified in FIGS. 51, 54 and 56, or they may be spaced apart by different amounts. If the axial length of a cyclone is about 80 mm, then the axial distance between dirt outlet regions 190 may be 1-6 mm, 1.5-4 mm or 2-3 mm. It will be appreciated that, if the axial length and/or diameter of a cyclone increases, then the axial distance between dirt outlet regions 190 may be increased.

Still referring to FIGS. 4-5, cyclone air flow path 212 may have an axial flow width 216 (i.e. measured parallel to longitudinal axis 204) approximately equal to an axial width 220 (i.e. measured parallel to longitudinal axis 204) of cyclone air inlet 184. Axial flow width 216 may remain generally constant between cyclone air inlet 184 and cyclone second end 208. Cyclone dirt outlet regions 190 may have any axial width 224 suitable for allowing dirt separated from the air flow to exit cyclone chamber 154 towards dirt collection chamber 156. Preferably, axial dirt outlet width 224<sub>1</sub> (or axial width 224 of each dirt outlet region 190) is between 35% and 90% of axial air inlet width 220 (i.e. about 35% to 90% of axial air flow path width 216). A width 224 within this range may be large enough to permit common

dirt particle sizes to exit freely through the cyclone dirt outlet region **190**, and yet may not be so large that a detrimental amount of the air flow is diverted from cyclone chamber **154** through cyclone dirt outlet region **190**.

In other embodiments, axial dirt outlet width **224**<sub>1</sub> may be between 15% and 150% of axial air inlet width **220** (i.e. about 15% to 150% of axial air flow path width **216**), between 25% and 125%, between 40% and 75% or between 50% and 60%. The lower portion of this range (e.g., 10% to 50% or 15% to 35% of axial air inlet width **220**) may minimize the amount of the air flow that diverts through cyclone dirt outlet **190** while still permitting at least small dirt particles to exit. The upper portion of this range (e.g., 75% to 150%, 90% to 150% or 100% to 125% of axial air inlet width **220**) may allow very large dirt particles to exit, although a somewhat greater amount of air flow may divert through cyclone dirt outlet region **190**.

Accordingly, if the axial length of a cyclone is about 80 mm, then the axial dirt outlet width **240** may be 1-18 mm, 2-6 mm, 3-5, or 4 mm. It will be appreciated that, if the axial length and/or diameter of a cyclone increases, then the axial outlet width **224** may be increased. Expressed differently, the axial dirt outlet width **224** may be 2-8%, 3-7% or 5% of the axial length of the cyclone.

The axial dirt outlet width **224** and/or axial distance between dirt outlet regions **190** may decrease from the forward location at which the dirt outlet regions **190** commence to the rear end of the location where the dirt outlet regions **190** terminate.

A dirt outlet region **190** may extend around part or all of the cyclone chamber sidewall, optionally in a plane transverse to the cyclone axis of rotation. For example, a dirt outlet region **190** may extend in an arc that extends 10-180°, 25-120°, 35-90° or 45-75° around the cyclone chamber sidewall. Each dirt outlet may have the same arc or a different arc.

It will be appreciated that the dirt outlet regions **190** may have the same size (e.g. width, length, and/or area) or may be differently sized and/or differently shaped. As exemplified in FIGS. **3**, **9-11**, **51**, **54** and **56**, the dirt outlet regions are rectangular in shape. Alternately, the dirt outlet regions may have rounded angularly spaced apart ends (see FIGS. **57-59**), they may be oblong (see FIGS. **60-62**), they may have concave angularly extending walls (see FIGS. **63-65**), convex angularly extending walls (see FIG. **70**) or both concave and convex angularly extending walls (see FIGS. **67-69**). Alternately, or in addition, as exemplified in FIG. **71**, the axial dirt outlet width **224** of all (or some) of the dirt outlet regions **190** may be different. As exemplified, the axial dirt outlet width **224** may decrease (or decrease continually as exemplified) from the forward most dirt outlet region **190**<sub>1</sub> to the rearward most dirt outlet region **190**<sub>5</sub>.

Alternatively, or in addition, the alignment of first dirt outlet region **190**<sub>1</sub> with a cyclonic portion of cyclone air flow path **212** may be such that at least 50%, 60%, 70%, 80%, 90% or more of the area of first dirt outlet region **190**<sub>1</sub> is coincident with (e.g., extends continuously along) the cyclone air flow path **212**. This may expose separated dirt particles to first dirt outlet region **190**<sub>1</sub> for an extended continuous distance along cyclone air flow path **212**, whereby the dirt particles may be more likely to exit through first dirt outlet **190**<sub>1</sub>, all else being equal.

The alignment of first dirt outlet region **190**<sub>1</sub> with the cyclone air flow path **212** may be such that both an upstream end **228** of dirt outlet region **190**<sub>1</sub> and a downstream end **232** of dirt outlet region **190**<sub>1</sub> are each located along a portion of the cyclone air flow path **212**. For example, dirt outlet region

**190**<sub>1</sub> may extend contiguously along a part of the cyclone air flow path **212** from dirt outlet upstream end **228** to dirt outlet downstream end **232**.

Referring to FIG. **4**, first dirt outlet region **190**<sub>1</sub> may have any axial position (i.e. with respect to cyclone longitudinal axis **204**) between cyclone first end **206** and second dirt outlet **190**<sub>2</sub>. In some embodiments, first dirt outlet region **190**<sub>1</sub> is axially offset from cyclone air inlet **184** by a distance **236** sufficient to permit at least some dirt particles within the air flow to separate (i.e. move outwardly to the cyclone sidewall **202**) as a result of the cyclonic character of air flow path **212**. For example, first dirt outlet region **190**<sub>1</sub> may be located at least one turn (i.e., a 360° segment) of cyclone air flow path **212** from cyclone air inlet **184**. In the illustrated example, first dirt outlet region **190**<sub>1</sub> is located just under 1.5 turns of cyclone air flow path **212** from cyclone air inlet **184**. Characterized another way, axial distance **236** from cyclone air inlet **184** to dirt outlet upstream end **228**, measured center-to-center may be at least equal to cyclone air inlet width **220** (i.e. at least about cyclone air flow width **216**). More generally, cyclone air inlet **184** may be spaced (center-to-center) from cyclone first end **206** by an axial distance **240** at least equal to cyclone air inlet width **220**.

Cyclone dirt outlet region **190**<sub>1</sub> may have any angular (i.e. circumferential) position on cyclone sidewall **202**. In some embodiments, cyclone dirt outlet region **190**<sub>1</sub> is angularly located at a bottom end **244** of cyclone sidewall **202** as shown. This location allows gravity to assist with moving separated dirt particles through cyclone dirt outlet **190**<sub>1</sub>. In other embodiments, cyclone dirt outlet region **190**<sub>1</sub> may be angularly offset from sidewall bottom end **244**. Although such positions may not benefit from gravity assistance for discharging separated dirt particles, they may advantageously provide greater flexibility to position cyclone dirt outlet region **190**<sub>1</sub> at a distance **252** along cyclone air flow path **212**, at which cyclonic particle velocities and residency time are optimized for separation efficiency (e.g. at the power mode(s) provided by apparatus **100**). As an example, FIGS. **6-7** show cyclone dirt outlet region **190**<sub>1</sub> angularly located between sidewall top and bottom ends **248**, **244**. In the example shown, cyclone dirt outlet region **190**<sub>1</sub> has a path distance **252** of about one turn (e.g. 360 degrees) from cyclone air inlet **184**.

Referring to FIG. **5**, cyclone dirt outlets **190** may have any orientation that is suitable for allowing dirt particles to exit cyclone chamber **154**. For example, one of cyclone dirt outlets region **190** (or both as shown) may be oriented such that they have a radial projection **256** (i.e. onto a plane **260** that includes cyclone longitudinal axis **204**) wherein the long direction is oriented transverse (e.g. perpendicular) to cyclone longitudinal axis **204**. For example, a cyclone dirt outlet region **190** may have a projected axis **264** that is transverse (e.g. perpendicular) to longitudinal axis **204**. As shown in FIG. **4**, this may permit cyclone dirt outlet(s) region **190** to be oriented in alignment with cyclone air flow path **212**.

FIG. **5** shows an example in which projections **256** (and projected axes **264**) are substantially perpendicular to cyclone longitudinal axis **204**. FIGS. **8-9** show an example in which projections **256** (and projected axes **264**) are not perpendicular. For example, projected axes **264** may be up to 30 or 45° from perpendicular with longitudinal axis **204**.

FIG. **8** shows dirt outlet regions **190** having a helical orientation, which may be aligned with the cyclonic air flow path through cyclone chamber **154**. As shown, each dirt outlet region **190** has an upstream end **228** located towards cyclone first end **206** relative to its downstream end **232**. An

advantage of this design is that it can allow a greater portion of the area of dirt outlet region regions 190 to extend continuously along a portion of the cyclonic air flow path in cyclone chamber 154.

FIG. 9 shows dirt outlet regions 190 having a helical orientation, which may be transverse (e.g. opposed to, misaligned, or counter-aligned) with the cyclonic air flow path through cyclone chamber 154. For example, if the cyclonic air flow path 212 from cyclone air inlet 184 is counterclockwise when viewed from cyclone first end 206 looking towards cyclone second end 208 as illustrated in FIG. 4, then one or both of dirt outlet regions 190 may extend clockwise from their outlet upstream end 228 to their outlet downstream end 232 as seen in FIG. 9 (or vice versa). An advantage of a transversely oriented dirt outlet 190 is that it may intersect several turns of the cyclone air flow path, which may expose the dirt outlet 190 to dirt particles having a wider range of residency time and particle velocities in the cyclonic flow. This may allow particles of different sizes sufficient time to separate from the air flow and make contact with cyclone sidewall 202. This design may also permit the dirt outlet region 190 to provide an effective exit for a wider range of air flow rates. Further, where the air flow path within cyclone 152 reverses direction at cyclone second end 208 to travel towards cyclone air outlet 188 (e.g. through cyclone chamber outlet passage 192, see FIG. 2) this design may align the dirt outlet region 190 with the reversed portion of the air flow path (i.e. the ‘counter-flow’ portion of the air flow path).

FIGS. 10 and 11 illustrate examples in which dirt outlet region 190<sub>1</sub> is oriented differently from dirt outlet region 190<sub>2</sub>. As shown, one of dirt outlet regions 190 may have a radial projection 256 (and projected axis 264) that is substantially perpendicular to cyclone longitudinal axis 204, and one of dirt outlet regions 190 may have a radial projection 256 (and projected axis 264) that is transverse but not perpendicular to longitudinal axis 204. The illustrated examples show second dirt outlet region 190<sub>2</sub> having a radial projection 256<sub>2</sub> (and projected axis 264<sub>2</sub>) that is substantially perpendicular to cyclone longitudinal axis 204, and first dirt outlet region 190<sub>1</sub> having a helical orientation. An advantage of this design is that it allows first dirt outlet region 190<sub>1</sub> to be positioned and oriented to provide an effective dirt outlet for lower air flow rates, while second dirt outlet region 190<sub>2</sub> is bordered by cyclone second end 208 for discharging dirt that passes first dirt outlet region 190<sub>1</sub> and piles against cyclone second end 208. In FIG. 10, first dirt outlet region 190<sub>1</sub> is illustrated with a helical orientation aligned with the cyclonic air flow path through cyclone chamber 154. In FIG. 11, first dirt outlet region 190<sub>2</sub> is illustrated with a helical orientation that is transverse (e.g. opposed, misaligned, or counter-aligned) to the cyclonic air flow path through cyclone chamber 154.

Reference is now made to FIG. 12. In some embodiments, first dirt outlet region 190<sub>1</sub> may have a long direction that may be oriented parallel (e.g.  $\pm 15^\circ$  of parallel) with cyclone longitudinal axis 204. An advantage of this design it that is can allow first dirt outlet region 190<sub>1</sub> to intersect several turns of the cyclone air flow path. This allows dirt outlet region 190<sub>1</sub> to provide an exit for dirt particles that have experienced a wider range of residency time and particle velocities in the cyclonic flow. In turn, this may allow particles of different sizes sufficient time to separate from the air flow and make contact with cyclone sidewall 202. This design may also permit the dirt outlet region 190 to provide an effective dirt outlet for a wider range of air flow rates. As shown, first dirt outlet region 190<sub>1</sub> may have a radial

projection 256<sub>1</sub> (and projected axis 264<sub>1</sub>) that is parallel to cyclone longitudinal axis 204.

FIG. 13 shows an embodiment in which the long direction of first dirt outlet region 190<sub>1</sub> has an orientation that is between a transverse and a parallel orientation relative to cyclone longitudinal axis 204. Such an orientation may provide a balance between (i) providing some degree of alignment with the cyclonic air flow path through cyclone chamber 154 in one of the forward direction (i.e. from cyclone first end 206 towards cyclone second end 208) or the reverse direction (i.e. from cyclone second end 208 towards cyclone first end 206), and (ii) exposing the dirt outlet 190<sub>2</sub> to several turns of the cyclonic air flow path.

Reference is now made to FIGS. 14-16. As shown, some embodiments of cyclone 152 may have first dirt outlet region 190<sub>1</sub> contiguous with second dirt outlet 190<sub>2</sub>. Accordingly, as opposed to, e.g., FIG. 13 wherein two discrete outlet slots are provided, a single outlet slot or opening or gap in the sidewall may be provided which comprises two or more dirt outlet regions. An advantage of this design is that it may provide, where the first and second dirt outlet regions 190<sub>1</sub> and 190<sub>2</sub> meet, an outlet region having a large outlet width and length, which can accommodate especially large dirt particles. In the illustrated example, the first and second dirt outlet regions 190<sub>1</sub> and 190<sub>2</sub> have different orientations relative to cyclone longitudinal axis 204. As shown, first dirt outlet region 190<sub>1</sub> may have a downstream end 232 that is connected to second dirt outlet region 190<sub>2</sub>. Downstream end 232 may be positioned towards cyclone second end 208 relative to cyclone first end 206. This may provide the combination of dirt outlet regions 190<sub>1</sub> and 190<sub>2</sub> with a “T-shape” configuration. As shown in FIG. 14, first dirt outlet region 190<sub>1</sub> may be oriented substantially parallel to cyclone longitudinal axis 204. As shown in FIGS. 15-16, first dirt outlet region 190<sub>1</sub> may have a curved shape that is oriented neither parallel nor perpendicular to cyclone longitudinal axis 204.

Referring to FIGS. 17-19, cyclone 152 may have three dirt outlet regions 190 in some embodiments. As shown, third dirt outlet region 190<sub>3</sub> may be oriented transverse to first and second dirt outlet regions 190<sub>1</sub> and 190<sub>2</sub>. First and second dirt outlet regions 190<sub>1</sub> and 190<sub>2</sub> may be oriented the same (as shown), or differently from each other. An advantage of this design is that it may permit (i) first dirt outlet region 190<sub>1</sub> to be oriented best to provide an exit for dirt particles when operating at low air flow rates, (ii) second dirt outlet region 190<sub>2</sub> to provide an exit for particles that reach cyclone second end 208, and (iii) third dirt outlet region 190<sub>3</sub> to interact with several turns of the cyclonic air flow path, which as discussed above may provide an exit for dirt particles that have experienced a wider range of residency time and particle velocities in the cyclonic flow, allow particles of different sizes sufficient time to separate from the air flow and make contact with cyclone sidewall, and/or provide an effective dirt outlet for a wider range of air flow rates.

As shown, the combination of dirt outlet regions 190<sub>1</sub>, 190<sub>2</sub>, 190<sub>3</sub> may have an “H-shape” or “N-shape” configuration. In the illustrated embodiment, third dirt outlet region 190<sub>3</sub> is contiguous with first and second dirt outlets 190<sub>1</sub> and 190<sub>2</sub>. As exemplified, third dirt outlet 190<sub>3</sub> has an upstream end 228<sub>3</sub> connected to first dirt outlet region 190<sub>1</sub>, and a downstream end 232<sub>3</sub> connected to second dirt outlet region 190<sub>2</sub>. In alternative embodiments, third dirt outlet region 190<sub>3</sub> may be spaced apart from (e.g. discontinuous with) one or both of first and second dirt outlet regions 190<sub>1</sub>, 190<sub>2</sub> such that two or 3 discrete outlets are provided. FIG. 17 shows an

example in which third dirt outlet region **190**<sub>3</sub> is oriented parallel to cyclone longitudinal axis **204**. FIGS. **18-19** show examples in which third dirt outlet region **190**<sub>3</sub> is oriented non-parallel to cyclone longitudinal axis **204** (e.g. neither perpendicular nor parallel to cyclone longitudinal axis **204**, as shown).

In other embodiments, first dirt outlet region **190**<sub>1</sub> may be spaced apart from (e.g. discontinuous with) second dirt outlet **190**<sub>2</sub>, as illustrated in the examples of FIGS. **3-13**.

Referring to FIG. **4**, any or all of dirt outlet regions **190** may be formed in cyclone sidewall **202**. For example, a dirt outlet **190** may include an aperture (e.g. hole or slot) in cyclone sidewall **202** that allows separated dirt particles to exit cyclone chamber **154** towards dirt collection chamber **156**. In the illustrated example, dirt outlet regions **190** are formed in a portion of cyclone sidewall **202** that is common to dirt collection chamber **156**. An advantage of this design is that it provides the shortest travel distance from dirt outlet **190** to dirt collection chamber **156**, which may mitigate dirt particles collecting in an intervening passage. However, in alternative embodiments dirt outlet region **190** may provide an entrance to a passage leading to dirt collection chamber **156**. This may provide greater flexibility in the location of dirt collection chamber **156** relative cyclone chamber **154**, such as to optimize apparatus **100** for compactness. Embodiments having a dirt outlet passage are discussed below.

FIG. **4** shows an example in which dirt outlet regions **190** are formed as slots in cyclone sidewall **202** (e.g., an open having a long dimension that extends circumferentially around a portion of the sidewall). As shown in FIG. **20**, a dirt outlet region **190** may be formed as an array of 4 or more closely arranged discrete apertures **268** that collectively define the dirt outlet region **190**. As compared to a slot, an array of apertures **268** may provide many smaller apertures that are discontinuous with each other. This may help to reduce the amount of the air flow which diverts into dirt collection chamber **156**, which in turn may reduce the backpressure and re-entrainment of collected dirt that can result from such divergence. A dirt outlet region **190** may be composed of an array of 4 or more (e.g., 5, 6, 7, 8, 9 or 10) closely arranged apertures **268** organized in any pattern. In the illustrated embodiment, each dirt outlet region **190** is formed as 4 equally sized apertures **268** arranged linearly in a single row. In other embodiment, each dirt outlet region **190** may be formed from more than 4 apertures, which may be the same or differently sized, and which may be arranged in one or many rows (or in a different non-linear pattern). It is expressly contemplated that any embodiment described or shown herein as a slot may also be formed in another embodiment as an array of apertures.

Cyclonic Air Treatment Member with a Plurality of Apertures

Embodiments herein relate to an improved cyclonic air treatment member that may have a plurality of small dirt outlets, which may be referred to as “apertures” or “perforations”. The features in this section may be used by themselves in any surface cleaning apparatus or in any combination or sub-combination with any other feature or features described herein. For example, a cyclone may have a plurality of apertures as well as one or more slots as described herein. If a combination of a slot and apertures are used, the apertures may be provided in one or more group of apertures, and one or more groups of apertures may be provided at or proximate a location of the slot or spaced therefrom. If a combination of slots and apertures are used, the apertures may be provided in one or more group of apertures, and one or more groups of apertures may be

provided at or proximate a location of each slot or spaced therefrom. For example, a group of apertures may be positioned between a pair of spaced apart slots. Alternately, a cyclone may have only a plurality of apertures as the dirt outlet.

As exemplified in FIGS. **21-22**, in some embodiments cyclone **152** includes one or more groups **272** of small apertures **274** (e.g. 10 or more apertures **274**) adjacent one or more (or all) of dirt outlet regions **190**. For example, a group **272** may be located towards cyclone first end **206** relative to the adjacent dirt outlet region **190** (e.g. upstream of the adjacent dirt outlet region **190**). Aperture group **272** may provide an exit for small dirt particles which remain open in the event that the adjacent dirt outlet region **190** becomes clogged. As shown, each group **272** may be angularly aligned (e.g. circumferentially aligned) with its respective adjacent dirt outlet region **190**. The illustrated embodiment shows a first group **272**<sub>1</sub> of apertures adjacent dirt outlet region **190**<sub>1</sub> and located between first dirt outlet region **190**<sub>1</sub> and cyclone first end **206**, and a second group **272**<sub>2</sub> of apertures adjacent dirt outlet region **190**<sub>2</sub> and located between second dirt outlet **190**<sub>2</sub> and first dirt outlet **190**<sub>1</sub>. As shown, first group **272**<sub>1</sub> may be axially spaced from first end **206** and second group **272**<sub>2</sub> may be axially spaced from first dirt outlet **190**<sub>1</sub>. FIG. **23** shows an alternative embodiment in which second group extends from proximate second dirt outlet region **190**<sub>2</sub> to proximate first dirt outlet **190**<sub>1</sub>.

Returning to FIG. **21**, each aperture **274** may have a size (e.g. width, length, and/or area) that is substantially smaller than the associated adjacent dirt outlet region **190**. In some embodiments, aperture **274** may have a width **288** of between 0.10 inches to 0.20 inches. This may provide a size that accommodates most small dirt particles collected in domestic (e.g. residential and commercial) environments. More generally, apertures **274** may each have a width **288** of between 0.010 inches and 0.500 inches. Apertures **274** having a width **288** of between 0.010 inches and 0.10 inches may provide exits suitable for very fine particles, and may minimize the amount of the air flow that diverts from the cyclone chamber **154** through apertures **274**. Apertures **274** having a width **288** of between 0.20 inches and 0.50 inches may provide exits suitable for relatively larger particles, although somewhat more of the air flow may divert from cyclone chamber **154** through apertures **274**. This may provide an acceptable trade-off where the dirt particles targeted for collection by apparatus **100** tend to be larger.

As exemplified in FIGS. **72-79**, in some embodiments, the cyclone chamber **154** may include dirt outlet that is a group of small apertures **272**. It will be appreciated that there may be any number of apertures **274** in the group of apertures **272**. For example, the group of apertures **272** may have 10, 20, 30, or more apertures **274**. As exemplified, the group of small apertures **272** may be in communication with the dirt collection chamber **156** such that a separate dirt outlet region **190** is not needed to transfer dirt from the cyclone chamber **154** to the dirt collection chamber **156**. It will be appreciated that by using only apertures as the dirt outlet, larger dirt particles and elongate material (e.g., hair) will be retained in the cyclone chamber **154**. Accordingly, cyclone chamber **154** may function as a dirt collection chamber provided that screen **197** has openings therein which inhibit dirt remaining in cyclone chamber **154** from exiting via the cyclone air outlet.

As described previously, it will be appreciated that the group of apertures **272** may be positioned anywhere within the cyclone chamber **154**. For example, the apertures **274** may be positioned at the cyclone air outlet end of the

cyclone chamber 154. The cyclone air outlet end may be provided at the cyclone second end 206, while the cyclone air inlet may be provided at the cyclone first end 208.

In some embodiments, as described previously, the apertures 274 may be provided in a lower portion of the cyclone sidewall. Positioning the apertures 274 in the lower portion of the cyclone sidewall may allow gravity to assist with the removal of dirt from the cyclone chamber 154. As exemplified in FIGS. 72-79, the dirt collection chamber 156 may underlie the cyclone chamber 154, such that particles that exit the cyclone chamber 154 by passing through the cyclone sidewall 202, through the apertures 274, and into the dirt collection chamber or chambers 156 that may underlie the cyclone chamber 152.

In some embodiments, the surface cleaning apparatus 100 may include a second stage cyclone 152<sub>2</sub> downstream from the first stage cyclone 152<sub>1</sub>. It will be appreciated that each of the cyclone stages may include one or more cyclones in series and/or in parallel. The first stage cyclone 152<sub>1</sub> may be in communication with the second stage cyclone 152<sub>2</sub> such that air exits the first stage cyclone 152<sub>1</sub> and enters the second stage cyclone chamber 154<sub>2</sub> of the second stage cyclone 152<sub>2</sub>.

As described previously, the surface cleaning apparatus 100 may have a dirt collection chamber 156. In some embodiments, the dirt collection chamber 156 may collect dirt from one or more cyclones of a single cyclonic stage or different cyclonic stages. For example a dirt chamber 156 may collect dirt from the first stage cyclone 152<sub>1</sub> and the second stage cyclone 152<sub>2</sub>. Alternately, each cyclonic stage may have one or more dirt collection chambers. For example, as exemplified in FIGS. 72-79, a surface cleaning apparatus may have two or more cyclonic stages, each of which comprises one or more cyclones and one or more dirt collection chambers 156. As exemplified, the first stage cyclone 152<sub>1</sub> is in communication with a first dirt collection chamber 156<sub>1</sub> and the second stage cyclone 152<sub>2</sub> is in communication with a second dirt collection chamber 156<sub>2</sub>. As exemplified, the dirt collection chambers 156<sub>1</sub> and 156<sub>2</sub> are external to the cyclone chambers.

It will be appreciated that all or a portion of each of the first dirt collection chamber 156<sub>1</sub> and the second dirt collection chamber 156<sub>2</sub> may underlie a cyclone chamber. As exemplified in FIGS. 72-79, all or a portion of each of the first dirt collection chamber 156<sub>1</sub> and the second dirt collection chamber 156<sub>2</sub> may underlie cyclone chamber 154. Accordingly, for example, the cyclone chamber 154 may have a first lateral side 320 that extends radially outwardly from centrally positioned cyclone longitudinal axis 204 in a first direction (e.g., the right side when viewed from the front as shown in FIG. 75) and a second lateral side 322 that extends radially outwardly from the cyclone longitudinal axis 204 in a second direction opposed to the first direction (e.g., the left side when viewed from the front as shown in FIG. 75).

As exemplified, the first dirt collection chamber 156<sub>1</sub> may be positioned on the first lateral side 320, while the second dirt collection chamber 156<sub>2</sub> may be positioned on the second lateral side 322. The two chambers 156<sub>1</sub>, 156<sub>2</sub> may be separated by a partition 324. The partition 324 may also be used to separate the first lateral side 320 from the second lateral side 322. As exemplified in FIGS. 72-29, all of the first dirt collection chamber 156<sub>1</sub> underlies the first cyclone chamber 154<sub>1</sub> and the forward portion of the second dirt collection chamber 156<sub>2</sub> (which comprises a majority of the volume of the second dirt collection chamber) may underlie the first cyclone chamber 154<sub>1</sub>.

It will be appreciated that the apertures 272 may be positioned on the first lateral side 320, the second lateral side 322, or both, depending upon the dirt collection chamber with which they communicate. In the embodiment exemplified in FIG. 75, the first stage cyclone 152<sub>1</sub> is located on the first lateral side 320 and the apertures 272 are located only on the first lateral side 320, as exemplified in FIGS. 72-79 and more clearly shown in FIG. 76. Positioning the apertures 272 only on the first lateral side 320 enables the apertures to only communicate with the first stage cyclone 152<sub>1</sub>. Accordingly, it will be appreciated that the apertures of the first stage cyclone chamber may be provided at any location which enables the apertures to communicate only with the first stage cyclone 152.

As described above, the group of apertures 272 in the first cyclone chamber 154<sub>1</sub> may be positioned on the first lateral side 320. Accordingly, when the surface cleaning apparatus 100 is in operation, dirt separated in the first cyclone 152<sub>1</sub> and of a size to pass through the apertures 274 may exit the first cyclone chamber 154<sub>1</sub> through the apertures 274 and may enter the first dirt chamber 156<sub>1</sub>. Dirty air may pass downstream from the first stage cyclone 152<sub>1</sub> into the second stage cyclone 152<sub>2</sub>. The second stage cyclone 152<sub>2</sub> may separate dirt from the air, depositing dirt in the second dirt collection chamber 156<sub>2</sub>, which is located on the second lateral side 322. As exemplified, the surface cleaning apparatus is a hand vacuum cleaner which, in use, may be angled with the dirty air inlet 108 angled downwardly. Therefore, in use, dirt will tend to travel to a forward portion of each of the dirt collection chambers 156.

Dirt that is larger than apertures 274 and smaller than the openings of the cyclone air outlet will remain in the first cyclone chamber 154<sub>1</sub>, and, accordingly, first cyclone chamber 154<sub>1</sub> is used as a dirt collection chamber. As exemplified in FIGS. 72-79, the surface cleaning apparatus 100 is a hand vacuum cleaner. Using the first stage cyclone chamber 154<sub>1</sub> as a dirt collection chamber may allow for the reduction in size of the hand vacuum cleaner 100 while maintaining the storage capacity.

Optionally, the dirt collection chambers 156<sub>1</sub> and 156<sub>2</sub> are concurrently emptyable, optionally concurrent with emptying the first stage cyclone chamber 154. Accordingly, each of the dirt collection chambers 156<sub>1</sub> and 156<sub>2</sub> may have an openable end that are opened concurrently. Alternately, or in addition, the first stage cyclone chamber 154 may have a portion that opens by itself or concurrently with one or both of the dirt collection chambers 156<sub>1</sub> and 156<sub>2</sub>.

As exemplified in FIGS. 72 and 73, the first cyclone 152<sub>1</sub> has an openable front. As exemplified, the first cyclone 152<sub>1</sub> has a stationary portion 330 and an openable portion 332 and the openable portion 332 is moveably mounted by a mount 334. As exemplified, the openable portion 332 may be a part of the lower end of the surface cleaning apparatus 100. For example, the mount 334 may be a hinge and/or pivot. The openable portion 332 may be movable between a closed position (see for example FIGS. 76-79), in which the first cyclone chamber 154<sub>1</sub> and the first dirt collection chamber 156<sub>1</sub> are closed, and an open position, in which the first cyclone chamber 154<sub>1</sub> and the first dirt collection chamber 156<sub>1</sub> are open (see for example FIGS. 72 and 73).

Optionally, as exemplified, the openable portion 332 includes a portion of the cyclone sidewall 202 (e.g., the sidewall may be part of each of the openable and stationary portions).

Each of the dirt collection chambers has a port 158, which as exemplified may be at the front end of the openable portion (e.g., they may be provided in a front face 336

thereof). Accordingly, during use, the openable portion **332** may be opened (e.g., it may be rotated so that front face **336** faces downwardly. In this orientation the contents of the first dirt collection chamber **156<sub>1</sub>**, and the second dirt collection chamber **156<sub>2</sub>** may concurrently be emptied, such as under the influence of gravity. If cyclone chamber **154** opens concurrently with the dirt chambers, then the cyclone chamber the first cyclone chamber **154<sub>1</sub>**, the first dirt collection chamber **156<sub>1</sub>** and the second dirt collection chamber **156<sub>2</sub>** may be concurrently emptied by orienting the moveable portion such that front face **366** faces downwardly.

Cyclonic Air Treatment Member with One or More Dirt Outlets Extending Axially on the Cyclone Chamber Sidewall

Embodiments herein relate to an improved cyclonic air treatment member that may have one or more dirt outlets which extend in a generally axial direction along at least a portion of the cyclone chamber sidewall. The features in this section may be used by themselves in any surface cleaning apparatus or in any combination or sub-combination with any other feature or features described herein.

As discussed previously, FIGS. **14-19** exemplify embodiments wherein a portion of the dirt outlet extends axially or generally axially. In accordance with the feature discussed in this section, and as exemplified in FIGS. **28-34**, a cyclone **152** may have one or more dirt outlets **190**, each of which extends axially or generally axially. Accordingly, the dirt outlet may not include a portion that extends angularly around the cyclone chamber sidewall as discussed previously.

As exemplified in FIGS. **29** and **30**, dirt outlet **190** may have a length **224** that extends linearly in the axial direction generally parallel to the cyclone axis **204**. Alternately, similar to outlet **190<sub>1</sub>** of FIGS. **15** and **16** and outlet **190<sub>3</sub>** of FIGS. **18**, **19** the dirt outlet **190** may extend in a direction that is offset or slightly offset from the direction of the longitudinal axis **204**, e.g. by  $\pm$ about  $20^\circ$  or  $\pm 10^\circ$ . The dirt outlet **190** may extend linearly as exemplified in FIGS. **29** and **30** or angularly as similar to outlet **190<sub>1</sub>** of FIGS. **15** and **16** and outlet **190<sub>3</sub>** of FIGS. **18**, **19**.

The dirt outlet **190** has a transverse width **226** that extends in a circumferential direction of the cyclone chamber **154**. As shown in the example of FIG. **32**, the length **224** is greater than the width **226** (e.g., the length **224** may be 5, 10, 15 or 20 times the width **226**). As the air rotates within a cyclone chamber, the air will tend to stay in a band. The band may have an axial length about the axial length of a tangential air inlet. Accordingly, the dirt outlet **190** may have an axial length that is at least as long as the axial length of a tangential cyclone inlet, which may allow the dirt outlet **190** to underlie the axial length of an entire band of air in a turn of the cyclonic air flow path through cyclone chamber **154**. If the axial length of the dirt outlet is longer, then the dirt outlet **190** may underlie more than one turn of the air, e.g., it may underlie 1.5 or 2 turns of the air.

In some embodiments, as exemplified in FIGS. **28-34**, the cyclone dirt outlet may be formed as an opening or gap in the cyclone chamber sidewall **202**. In the illustrated embodiment, dirt outlet **190** is formed as a rectangular aperture in the sidewall **202**. In alternative embodiments, dirt outlet **190** may have other shapes (e.g. elliptical, triangular, irregular shapes) in which the length **224** is greater than the width **226**.

In some embodiments, the dirt outlet **190** is provided at a bottom end **244** of cyclone sidewall **202** as shown. This may help dirt which remains in the cyclone chamber **154** after termination of operation of the vacuum cleaner **100** to fall

into the dirt collection chamber **156** when the vacuum cleaner **100** is held with the cyclone **152** extending horizontally (and possibly slightly upwardly).

The dirt outlet extends between dirt outlet first or upstream end **193** and dirt outlet second or downstream end **194**. The dirt outlet upstream end **193** may be located at any location along the axial length of the cyclone **152**. For example, as exemplified in FIG. **31**, the dirt outlet upstream end **193** may be located at the front end of the cyclone **152** (cyclone first end **206**). Alternately, as exemplified in FIG. **47**, the dirt outlet upstream end **193** may be located axially inwardly from the front end of the cyclone **152**. For example, the dirt outlet upstream end **193** may be located at or axially inwardly (rearwardly) from the axially inner extent of the cyclone air inlet (see, e.g., FIG. **46**). As shown in FIGS. **28-34**, the cyclone air inlet **184** includes a conduit **129** that extends into, and is located interior to the cyclone chamber **154**. The open portion of the dirt outlet **190** may extend from a position located at or, e.g., about 0.01-0.2 inches axially inward from the axially inner side **185** of the air inlet conduit **129** towards the cyclone second end **208**.

Similarly, the dirt outlet downstream end **194** may be located at any location along the axial length of the cyclone **152**. For example, the dirt outlet downstream end **194** may be located at the rear end of the cyclone **152** (cyclone second end **208**). Alternately, as exemplified in FIG. **30**, the dirt outlet downstream end **194** may be located axially inwardly from the rear end of the cyclone **152**. For example, the dirt outlet downstream end **194** may be located at passage second end **276** or axially inwardly (forwardly) from the axially inner extent of the solid portion of the outlet passage **192** (see, e.g., FIG. **30**).

Accordingly, the dirt outlet **190** may be provided by an axially extending slot **191**, which is formed in the sidewall **202**, which extends longitudinally along at least a portion of the cyclone chamber **154** in a direction generally parallel to the cyclone axis **204** between dirt outlet upstream end **193** and dirt outlet downstream end **194**. As exemplified in FIGS. **29-31**, the length **225** of slot **191** may be greater than the open length **224** of the dirt outlet **190**. This may occur if, for example, the slot extends forwardly of the cyclone air inlet. In such a case, an insert member **230** may be provided to limit the forward extent of the slot **191** when the surface cleaning apparatus is in operation (i.e., the length of the slot **191** may be reduced due to insert member **230** to provide a dirt outlet upstream end **193** that is positioned at a selected forward extent of the cyclone **152**).

FIGS. **29-31** exemplify an embodiment wherein the slot **191** extends from a position at the cyclone first end **206** rearward towards the cyclone second end **208**. In this embodiment, the second end **194** of the slot **191** is axially spaced apart from the first end **193** and is located inwardly (forwardly) of the cyclone second end **208**. As shown in FIG. **30**, the slot **191** is positioned under cyclone air inlet **184**. Accordingly, air entering the cyclone **152** at the axial location of the cyclone air inlet **184** (i.e., between the forward and rearward extent of) could enter the slot **191**.

Optionally, as exemplified, an insert member **230** may be provided, and may be removably received in a slot portion **231** of the slot **191** proximate the cyclone first end **206** as shown. When the insert member **230** is received in the slot **191**, the insert member **230** can occupy the slot portion **231** and prevent dirt from exiting the cyclone chamber **154** via slot portion **231**. The open portion of the dirt outlet **190** may thus extend between the second end **194** and an open outlet



end **195**. As a result, in operation the open length **224** of the dirt outlet **190** may be less than the overall length **225** of the slot **191**.

The insert member may extend from the front end **206** of the cyclone rearwardly any desired amount. As exemplified in FIGS. **29-31**, the open outlet end **195** may be positioned proximate an axially inner side **185** of the tangential air inlet **184**. Accordingly, the insert member may extend inwardly to a position at the location of the axially inner side **185** and, optionally, rearwardly thereof (see for example FIG. **35**).

As exemplified in FIG. **2**, in some embodiments, first end **280** of passage **192** may be solid (i.e., it may not be porous). In such a case, the insert member **230** may extend to the inner end of the solid portion of screen **197**, and, optionally, rearwardly thereof such that the open outlet end **195** may be spaced axially inwardly (towards cyclone second end **208**) from the axially inner side **185**. Alternately, if the solid portion of screen **197** extends to the front end **206** of the cyclone, then an insert member **230** may not be provided.

Alternately, the passage first end **280** may be positioned longitudinally adjacent to the inner side **185** of the air inlet **184**. If the cyclone air inlet **184** is provided inside the cyclone chamber **154**, then the cyclone outlet passage **192** may extend to a position longitudinally adjacent (e.g., within 0.01, 0.05, 0.1 or 0.125 inches) to the end **185** of the tangential inlet **184** closest to the outlet end of the cyclone chamber **154**.

As shown in FIG. **30**, the passage first end **280** can be axially spaced inwardly from the inner side **185** of air inlet conduit **129**. For example, the first end **280** of the cyclone outlet passage **192** may terminate at about 0.01-0.75 or about 0.05-0.375 inches inwardly from the inner side **185** of the air inlet **184** in some embodiments. Alternately, in some embodiments, the first end **280** of the cyclone outlet passage **192** may abut the downstream wall **183** of the air inlet conduit **129**.

As discussed subsequently, in some embodiments, the cyclone outlet passage **192** may be tapered between the passage second end **276** and the passage first end **280**. As shown in FIG. **30**, the transverse width of the cyclone outlet passage **192** may increase gradually between passage first end **280** and passage second end **276**. This may provide a greater radial distance between the cyclone chamber sidewall **202** and the cyclone outlet passage **192** at the air inlet end of the cyclone chamber **154** thereby inhibiting dirt from contacting the screen **197** as it enters the cyclone chamber **154**.

In some embodiments, the cyclone first end **206** may be openable. As shown in FIG. **31**, the cyclone first end **206** may be defined by an openable front wall **207**. The front wall **207** may be movable between a closed position (shown for example in FIGS. **28-30**) and an open position (shown in FIG. **31**). As illustrated, when the front end **206** is moved to the open position, the cyclone chamber **154** and the dirt collection chamber **156** are each opened. This may facilitate emptying dirt and debris from the cyclone **152**.

Alternately or in addition, the cyclone chamber **154** and dirt collection chamber **156** may be separately openable.

As exemplified in FIG. **31**, if an insert member **230** is provided, then the insert member **230** can be mounted to the front wall **207**. Accordingly, as the cyclone front end **206** is moved to the open position, the insert member can be removed from the dirt outlet portion **231**. This may provide additional access to dirt collection chamber **156** to facilitate emptying.

As shown, the cyclone outlet passage **192** can be tapered. The reduction in width of the passage **192** moving from the

second end **176** to the first end **280** may allow the insert member **230** to have a greater axial length while still permitting the insert member **230** to be withdrawn from the dirt outlet slot **191**.

It will be appreciated that, instead of providing an insert member **230** to close part of slot **191**, slot **191** may have the same dimensions as dirt outlet **190**. Such an embodiment is exemplified in FIGS. **45-47**, wherein the cyclone **152** is not provided with an insert member **230**. Rather, as exemplified, the dirt outlet **190** may be defined entirely by a gap/slot **191** in the cyclone chamber sidewall **202**. The cyclone chamber sidewall **202** may include a section **203** that extends from proximate the front end **206** to the dirt outlet first end **193**. A gap **191** in the sidewall **202** extending rearward from the dirt outlet first end **193** (the open outlet end **195**) may then define the dirt outlet **190**. Accordingly, the dirt outlet first end **193** can be positioned at the same location as discussed with respect to the open outlet end **195**, i.e., it may be positioned proximate to the second end **185** of the tangential air inlet **184**.

FIGS. **35-38** exemplify an embodiment wherein the open portion of the dirt outlet **190** is axially spaced apart (inwardly) from the second end **185** of the air inlet **184** towards the cyclone second end **208**. This may also reduce the re-entrainment of collected dirt from the dirt collection chamber **156**, particularly if outlet passage **192** is not tapered.

In the example shown in FIGS. **35-38**, the insert member **230** extends axially from the cyclone first end **206** towards the cyclone second end **208** for a distance beyond the inner side **185** of the air inlet conduit **129**. As a result, the open outlet end **195** is axially spaced apart from the inner side **185** of the air inlet conduit **129**. In operation, the open length **224** of the dirt outlet **190** is thus much less than the overall length **225** of the slot **191**.

Depending upon the length of the insert member **230**, the diameter of the cyclone chamber **154** and the diameter of the passage **192**, the top side **233** of the insert member **230** may contact the cyclone outlet passage **192** and may brush against the screen **197** when the insert member **230** is removed from the cyclone chamber when the cyclone front end **206** is moved to the open position (see for example FIGS. **37-38**). In such an embodiment, the insert member **230** may thus help dislodge dirt and debris from the screen **197** to facilitate cleaning thereof. To facilitate the removal of the insert member **230** in such an embodiment, the insert member may be flexible or bendable (e.g., it may be made of a resilient material) and/or the outlet passage **192** may be tapered and or shorter.

As exemplified, if the insert member **230** extends past the cyclone inlet, then the cyclone outlet passage **192** can be tapered. The reduction in width of the passage **192** moving from the second end **176** to the first end **280** may allow the insert member **230** to be more easily withdrawn from the dirt outlet slot **191**.

Optionally, the insert **230** may be flexible or bendable. As the front end **206** is opened, the insert member **230** may contact the cyclone outlet passage **192** and press on the screen **197**. As shown in FIGS. **37-38**, insert member **230** can flex in response to pressing against the outlet passage **192** to allow the insert member **230** to be removed without damaging or displacing the outlet passage **192**, while still assisting in cleaning the screen **197**.

In the example shown in FIGS. **35-38**, the insert member **230** has a generally triangular shape. The triangular shape of

the insert member **230** may support the insert member **230** and prevent flexing or bending in response to air flow in the cyclone chamber **154**.

Alternately, other shapes of insert member **230** may be used. Referring to FIGS. **39-41**, shown therein is another example of a cyclone **152** with a rectangular insert member **230**. The rectangular insert member **230** shown in FIGS. **39-41** may occupy less space allowing for increased capacity in the dirt collection chamber **156**.

As exemplified in FIGS. **42-44**, in some embodiments the cyclone air inlet **184** may terminate at a cyclone inlet port **187** formed in the sidewall **202** of the cyclone chamber **154**. In the example illustrated, the cyclone inlet port **187** is the terminal end of a tangential inlet and is an opening formed in the longitudinally extending sidewall **202**. The cyclone air inlet **184** extends from a cyclone air inlet upstream end **310** to a cyclone air inlet downstream end **312**. The cyclone air inlet downstream end **312** may be oriented to direct air substantially tangentially to the inner surface of sidewall **202**.

In the illustrated example of FIGS. **42-44**, cyclone air inlet **184** is formed as a curved passage **315** extending from a cyclone air inlet upstream end **310** to a cyclone air inlet downstream end **312**. The curved passage **315** may provide a gradual change of direction for the air passing through the cyclone air inlet **184**, which may reduce backpressure through the cyclone air inlet **184**.

The cyclone air inlet **184** has an inlet width that extends between a first inlet side **179** and a second inlet side **185**. In the example illustrated, the first inlet side **179** and second inlet side **185** are spaced apart in a longitudinal axial direction generally parallel to the cyclone axis of rotation **204**. The second inlet side **185**, or downstream inlet side, is positioned closer to the cyclone second end **208** than the first inlet side **179**.

As exemplified, where the cyclone air inlet **184** terminates at a port **187** in the cyclone chamber sidewall **202** such as exemplified in FIGS. **42-44**, the first end **208** of the passage **192** may be located at the second inlet side **185** or, alternately, it may be located axially inwardly of the second side **185** of the tangential air inlet **184** (i.e., towards cyclone second end **208**), for example, 0.01, 0.05, 0.1 or 0.125 inches inwardly of second inlet side **185**.

In alternate embodiments, the first end **208** of the cyclone outlet passage **192** may extend to a position at or adjacent (e.g., within 0.01, 0.05, 0.1 or 0.125 inches) of the first end **206** of the cyclone chamber **154**. For example, the passage first end **280** may terminate at about 0.01-0.75 inches or about 0.05-0.375 inches from the cyclone first end **206** in some embodiments. In such a case, the portion of cyclone outlet passage that is axially co-extensive with port **187** may be solid.

As exemplified in FIGS. **48-49**, in some embodiments the cyclone **152** may include a plurality of axially extending dirt outlet **190<sub>1</sub>**, **190<sub>2</sub>**, and **190<sub>3</sub>**. This may allow the dirt outlets to intersect the air flow path through the cyclone chamber **154** at different locations, which may expose the dirt outlets **190<sub>1</sub>**, **190<sub>2</sub>**, and **190<sub>3</sub>** to dirt particles having a wider range of residency time and particle velocities in the cyclonic flow.

Each of dirt outlets **190<sub>1</sub>**, **190<sub>2</sub>**, and **190<sub>3</sub>** may be the same or different. Each dirt outlet **190<sub>1</sub>**, **190<sub>2</sub>**, and **190<sub>3</sub>** may be of any design discussed herein.

In the example illustrated in FIGS. **48** and **49**, the cyclone **152** omits and insert member **230** and a section **203** of the cyclone chamber sidewall **202** extends to the dirt outlets **190<sub>1</sub>**, **190<sub>2</sub>**, and **190<sub>3</sub>**, similar to the embodiment of FIGS. **45-47**, so that the dirt outlets **190<sub>1</sub>**, **190<sub>2</sub>**, and **190<sub>3</sub>** can be

positioned proximate the downstream end of the air inlet **184**. Alternately, an insert member may be used to define the extent of the dirt outlets **190<sub>1</sub>**, **190<sub>2</sub>**, and **190<sub>3</sub>**. Alternately, the dirt outlets **190<sub>1</sub>**, **190<sub>2</sub>**, and **190<sub>3</sub>** may extend to the front end of cyclone **152**.

In the example shown in FIGS. **48-49**, each dirt outlet **190<sub>1</sub>**, **190<sub>2</sub>**, and **190<sub>3</sub>** connects the cyclone chamber **154** to a separate dirt collection chamber **156<sub>1</sub>**, **156<sub>2</sub>**, and **156<sub>3</sub>**. This may reduce the amount of the air flow which diverts into each dirt collection chamber **156**, which in turn may reduce the re-entrainment of collected dirt that can result from such divergence.

Alternately, the plurality of dirt outlets **190** may be connected to a single dirt collection chamber **156**. This may provide an increased dirt collection volume and ensure that the entire dirt collection volume can be used instead of having the empty the dirt collection chambers **156<sub>1</sub>**, **156<sub>2</sub>**, and **156<sub>3</sub>** when one becomes filled.

Cyclone Air Outlet

Embodiments herein relate to an improved cyclonic air outlet. The features in this section may be used by themselves in any surface cleaning apparatus or in any combination or sub-combination with any other feature or features described herein.

As exemplified in FIG. **2**, cyclone chamber outlet passage **192** may have any shape that can provide an outlet passage for air exiting cyclone chamber **154**. Cyclone chamber outlet passage **192** may extend longitudinally from a passage second end **276** at cyclone second end **208** towards cyclone first end **206** (e.g. in parallel with cyclone longitudinal axis **204**) to a passage first end **280**. As shown, cyclone chamber outlet passage **192** may be spaced apart from cyclone sidewall **202** to define a surrounding annular region between cyclone chamber outlet passage **192** and cyclone sidewall **202** that promotes cyclonic air flow through cyclone chamber **154**.

In the illustrated embodiment, cyclone chamber outlet passage **192** has a transverse width **288** (e.g. diameter) that is substantially constant (e.g. varies by less than 10%) between passage first end **280** and passage second end **276**. Depending on the size and shape of cyclone sidewall **202**, this may provide the air flow path through cyclone chamber **154** with a relatively constant cross-sectional area.

In accordance with this feature, as exemplified in FIG. **22**, cyclone chamber outlet passage **192** may have a transverse width **288** that increases between passage first end **280** and passage second end **276** towards passage second end **276**. In other words, cyclone chamber outlet passage **192** may taper in transverse width **288** towards passage first end **280**. Depending on the size and shape of cyclone sidewall **202**, this may provide the air flow path through cyclone chamber **154** with a shrinking cross-sectional area as the air flow travels from cyclone air inlet **184** towards cyclone second end **208**. As a result of the inverse relationship between cross-sectional area and velocity, the progressive reduction in cross-sectional flow area may increase the flow velocity towards cyclone second end **208**. This may mitigate a loss of velocity and cyclonic degradation that may develop towards cyclone second end **208** particularly when operating at low flow rates (e.g. in a lower power mode). Consequently, the tapered cyclone chamber outlet passage **192** may promote greater overall separation efficiency for cyclone **152**.

As shown, transverse width **288** may increase continuously between passage first end **280** and passage second end **276**. In some embodiments, transverse width **288** may increase by at least 10% (e.g. by 10% to 200%, 25% to 175%, 40% to 125% or 60% to 90%) between passage first

end **280** and passage second end **276**. In the illustrated embodiment, transverse width **288** increases by about 125% between passage first end **280** and passage second end **276**.

As exemplified, passage first end **280** may be solid and may have an axial length that is at least as long as, or longer than, the axial inward extent of the cyclone air inlet. Accordingly, air that enters the cyclone chamber may not directly enter the outlet passage **192**, as the first end **280** is solid.

Although many of the figures illustrate concepts and embodiments applied to an exemplary handvac, all of the embodiments described herein apply equally to other surface cleaning apparatus (e.g. upright vacuums, canister vacuums, etc.). Further, although many of the figures illustrate a uniflow cyclone that is horizontally oriented, all embodiments disclosed here are also applicable to other cyclone configurations and orientations. As an example, FIGS. **24-25** show an upright vacuum **100** having a cyclonic air treatment member **116** with an inverted cyclone **152**. As shown, cyclone **152** has a central longitudinal axis **204** that is vertically oriented, a plurality of dirt outlet regions **190** (which may have any configuration disclosed in any embodiment herein), a cyclone chamber air outlet passage **192** (which may have any configuration disclosed in any embodiment here), and both the cyclone air inlet **184** and outlet **188** are located at cyclone first end **206**.

Reference is now made to FIGS. **26-27**. In some embodiments, a dirt outlet region **190** may provide an entryway to a dirt outlet passage **292** leading to dirt collection chamber **156**. This may be the case for the only dirt outlet region **190** of a cyclone **152** as shown, or for one or more (or all) dirt outlet regions **190** of a cyclone **152** having many dirt outlet regions **190** (e.g. as in any embodiment disclosed herein having two or more dirt outlets **190**). An advantage of providing a dirt outlet passage **292** between a dirt outlet region **190** and the dirt collection chamber **156** is that it may reduce the amount of air flow that diverts from the cyclone chamber **154** into the dirt collection chamber **156**. Diverted air flow can produce a pressure drop in the air flow through cyclone **152**, which may result in less suction and possibly lower dirt separation efficiency all else being equal. By mitigating pressure drops, a smaller, lighter, less expensive suction motor may be used to achieve the same suction, or greater suction may be achieved with the same suction motor. Further, diverted air flow may disturb dirt that has collected in dirt collection chamber **156**, which may lead to that dirt re-emerging into the cyclone chamber **154** through the dirt outlet region **190**. A dirt outlet passage **292** may help to mitigate dirt collected in dirt collection chamber **156** from returning to cyclone chamber **154**.

Dirt outlet passage **292** has a length **296** extending from dirt outlet region **190** to passage outlet **304**. Passage outlet **304** may be located inside dirt collection chamber **156** as shown, or may be formed in a sidewall of dirt collection chamber **156** (e.g., the outlet end may be a port provided in a sidewall of the dirt collection chamber **156**). Passage outlet **304** may have any passage length **296** suitable for directing dirt exiting from cyclone chamber **154** at a dirt outlet region **190** to dirt collection chamber **156**. Preferably, passage length **296** is greater than a thickness of cyclone chamber sidewall **202**. For example, passage length **296** may be greater than 5 mm (e.g. between 5 mm and 300 mm, 25-250 mm, 50-200 mm or 75-150 mm). A passage length **296** closer to 5 mm may be appropriate where, for example, cyclone chamber **154** and dirt collection chamber **156** share a common dividing wall **202**. A passage length much greater

than 5 mm (e.g. 50 mm or more) may be appropriate where, for example, cyclone chamber **154** and dirt collection chamber **156** are spaced apart.

Dirt outlet passage **292** may extend in any direction from dirt outlet region **190** towards dirt collection chamber **156**. In some embodiments, dirt outlet passage **292** is oriented tangential to cyclone chamber **154**. FIG. **26** shows an example in which dirt outlet passage **292** is oriented tangential cyclone chamber **154** in alignment with the direction of cyclone air flow path **212** where cyclone air flow path **212** crosses dirt outlet region **190**. An advantage of this design is that dirt outlet passage **292** may be oriented in the same direction as the direction of dirt particles at dirt outlet **190**. This may increase particle separation efficiency by reducing the number of dirt particles which cross over dirt outlet region **190** without exiting cyclone chamber **154**. However, such tangential alignment may also lead to a somewhat greater amount of the air flow diverting from cyclone chamber **154** into dirt collection chamber **156**. FIG. **27** shows an example in which dirt outlet passage **292** is oriented tangential to cyclone chamber **154** but extending in a direction opposed to the direction of cyclone air flow path **212** where cyclone air flow path **212** crosses dirt outlet **190**. An advantage of this design is that it may reduce the amount of air that diverts from cyclone chamber **154** to dirt collection chamber **156**, although a somewhat greater number of dirt particles may pass over dirt outlet **190** without exiting.

While the above description provides examples of the embodiments, it will be appreciated that some features and/or functions of the described embodiments are susceptible to modification without departing from the spirit and principles of operation of the described embodiments. Accordingly, what has been described above has been intended to be illustrative of the invention and non-limiting and it will be understood by persons skilled in the art that other variants and modifications may be made without departing from the scope of the invention as defined in the claims appended hereto. The scope of the claims should not be limited by the preferred embodiments and examples, but should be given the broadest interpretation consistent with the description as a whole.

The invention claimed is:

1. A vacuum cleaner comprising an air flow path extending from a dirty air inlet to a clean air outlet with a first cyclonic cleaning stage and a suction motor positioned in the air flow path, the first cyclonic cleaning stage comprising a first cyclone chamber and a first dirt collection chamber external to the first cyclone chamber, the first cyclone chamber having a cyclone first end, an opposed cyclone second end, a cyclone sidewall extending between the cyclone first end and the cyclone second end, a cyclone air inlet, a cyclone air outlet provided at the cyclone second end, a cyclone dirt outlet in communication with the first dirt collection chamber and a cyclone longitudinal axis extending from the cyclone first end to the cyclone second end, wherein the dirt outlet comprises a plurality of apertures, wherein the cyclone air outlet extends inwardly a first distance from the cyclone second end towards the cyclone first end, and wherein the cyclone sidewall extends angularly 360° around the cyclone longitudinal axis and a portion of the cyclone sidewall having the plurality of apertures extends angularly only part way around the cyclone longitudinal axis and wherein the portion of the sidewall extends inwardly into the cyclone chamber a distance that is up to about the first distance.

2. The vacuum cleaner of claim 1 wherein the plurality of apertures comprises more than 10 apertures.

3. The vacuum cleaner of claim 1 wherein the plurality of apertures comprises more than 20 apertures.

4. The vacuum cleaner of claim 2 wherein the apertures have a width of 0.10 inches to 0.20 inches.

5. The vacuum cleaner of claim 2 wherein the apertures have a width of 0.010 inches to 0.10 inches.

6. The vacuum cleaner of claim 1 wherein the apertures are provided at a cyclone air outlet end of the first cyclone chamber.

7. The vacuum cleaner of claim 6 wherein the cyclone air outlet end is the cyclone second end and the cyclone air inlet is provided at the cyclone first end.

8. The vacuum cleaner of claim 1 wherein the vacuum cleaner is a hand vacuum cleaner having an upper end and a lower end, the upper end has the dirty air inlet and, when the hand vacuum cleaner is oriented with the upper end above the lower end, the apertures are provided in a lower portion of the cyclone sidewall.

9. The surf vacuum cleaner ace cleaning apparatus of claim 8 wherein the cyclonic cleaning stage comprises a stationary portion and an openable portion, the openable portion is part of the lower end of the hand vacuum cleaner and comprises a portion of the cyclone sidewall and the openable portion is moveably mounted by a mount between a closed position in which the first cyclone chamber and the first dirt collection chamber are closed and an open position in which the first cyclone chamber and the first dirt collection chamber are open and the apertures are provided in the openable portion.

10. The vacuum cleaner of claim 8 wherein, when the hand vacuum cleaner is oriented with the upper end above the lower end, the first dirt collection chamber underlies the first cyclone chamber.

11. The vacuum cleaner of claim 1 wherein the first cyclone chamber has a first lateral side that extends radially outwardly from the cyclone longitudinal axis in a first direction and a second lateral side that extends radially outwardly from the cyclone longitudinal axis in a second direction that is opposed to the first direction and the apertures are provided only on the first lateral side of the first cyclone chamber.

12. The vacuum cleaner of claim 1 further comprising a second cyclonic cleaning stage downstream from the first cyclonic cleaning stage, the second cyclonic cleaning stage having a dirt collection region wherein, when the hand vacuum cleaner is oriented with the upper end above the lower end, the first dirt collection chamber and the dirt collection region each underlie the first cyclone chamber.

13. The vacuum cleaner of claim 12 wherein the second cyclonic cleaning stage comprises a second cyclone chamber and a second dirt collection chamber external to the

second cyclone chamber and the second dirt collection chamber comprises the dirt collection region.

14. The vacuum cleaner of claim 13 wherein the first cyclone chamber has a first lateral side that extends radially outwardly from the cyclone longitudinal axis in a first direction and a second lateral side that extends radially outwardly from the cyclone longitudinal axis in a second direction that is opposed to the first direction and the apertures are provided only on the first lateral side of the first cyclone chamber, the first dirt collection chamber is located on the first lateral side and the dirt collection region is located on the second lateral side.

15. A vacuum cleaner comprising:

- (a) a front end having a dirty air inlet, a rear end, and first and second laterally opposed sides, each laterally opposed side extends in a forward/rearward direction;
- (b) an air flow path extending from a dirty air inlet provided at the front end to a clean air outlet with a suction motor positioned in the air flow path;
- (c) a first air treatment stage positioned in the air flow path downstream from the dirty air inlet, the first air treatment stage comprising a first air treatment chamber and a first dirt collection chamber external to the first air treatment chamber; and,
- (d) a second air treatment stage positioned in the air flow path downstream from the first air treatment stage and rearward of the first air treatment chamber, the second air treatment stage comprising a second air treatment chamber and a second dirt collection chamber external to the second air treatment chamber,

wherein the first dirt collection chamber is provided on the first lateral side and underlies the first air treatment chamber and the second dirt collection chamber is provided on the second lateral side and underlies the first air treatment chamber, and

wherein the first dirt collection chamber and the second dirt collection chamber are emptyable concurrently.

16. The vacuum cleaner of claim 15 wherein the first air treatment chamber has a dirt outlet in communication with the first dirt collection chamber and the dirt outlet comprises a plurality of apertures.

17. The vacuum cleaner of claim 16 wherein the plurality of apertures comprises more than 10 apertures.

18. The vacuum cleaner of claim 16 wherein the plurality of apertures comprises more than 20 apertures.

19. The vacuum cleaner of claim 17 wherein the apertures have a width of 0.10 inches to 0.20 inches.

20. The vacuum cleaner of claim 17 wherein the apertures have a width of 0.010 inches to 0.10 inches.