



US010966582B2

(12) **United States Patent**
Conrad et al.

(10) **Patent No.:** **US 10,966,582 B2**

(45) **Date of Patent:** ***Apr. 6, 2021**

(54) **CYCLONE ASSEMBLY FOR SURFACE
CLEANING APPARATUS AND A SURFACE
CLEANING APPARATUS HAVING SAME**

(58) **Field of Classification Search**

CPC A47L 9/1641; A47L 9/1625; A47L 9/1683;
A47L 9/165; A47L 9/1666; A47L 9/1633;

(Continued)

(71) Applicant: **Omachron Intellectual Property Inc.,**
Hampton (CA)

(56) **References Cited**

U.S. PATENT DOCUMENTS

2,370,444 A 2/1945 Bowman et al.

2,754,968 A 7/1956 Vegter et al.

(Continued)

(72) Inventors: **Wayne Ernest Conrad,** Hampton
(CA); **Dave Petersen,** Bowmanville
(CA)

(73) Assignee: **Omachron Intellectual Property Inc.,**
Hampton (CA)

FOREIGN PATENT DOCUMENTS

(*) Notice: Subject to any disclaimer, the term of this
patent is extended or adjusted under 35
U.S.C. 154(b) by 0 days.

CN 1729924 A 2/2006

CN 1875846 A 12/2006

(Continued)

This patent is subject to a terminal dis-
claimer.

OTHER PUBLICATIONS

(21) Appl. No.: **16/698,106**

English translation of CN1875846, as published on Dec. 13, 2006.

(22) Filed: **Nov. 27, 2019**

(Continued)

(65) **Prior Publication Data**

US 2020/0093338 A1 Mar. 26, 2020

Related U.S. Application Data

Primary Examiner — Dung H Bui

(74) *Attorney, Agent, or Firm* — Philip C. Mendes da
Costa; Bereskin & Parr LLP/S.E.N.C.R.L., s.r.l.

(63) Continuation of application No. 15/492,937, filed on
Apr. 20, 2017, now Pat. No. 10,537,219, which is a
(Continued)

(57) **ABSTRACT**

A cyclone assembly for a surface cleaning apparatus has a
first cyclonic cleaning stage and a second cyclonic cleaning
stage downstream from the first cyclonic cleaning stage. The
second cyclonic cleaning stage has more air inlets than the
first cyclonic cleaning stage. The second cyclonic cleaning
stage has a second stage air inlet cross-sectional area in a
direction transverse to a direction of air flow entering the
second stage cyclone chamber that is 1.1-2 times larger than
a first stage air inlet cross-sectional area in a direction
transverse to a direction of air flow entering the first stage
cyclone chamber.

(51) **Int. Cl.**
B01D 45/12 (2006.01)
A47L 9/16 (2006.01)

(Continued)

(52) **U.S. Cl.**
CPC **A47L 9/1608** (2013.01); **A47L 5/28**
(2013.01); **A47L 9/106** (2013.01); **A47L 9/122**
(2013.01);

(Continued)

19 Claims, 46 Drawing Sheets

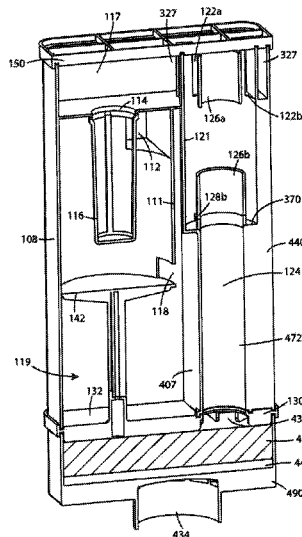

Related U.S. Application Data

continuation-in-part of application No. 15/391,128, filed on Dec. 27, 2016, now Pat. No. 10,258,210, which is a continuation-in-part of application No. 15/137,814, filed on Apr. 25, 2016, now Pat. No. 9,936,846.

(51) **Int. Cl.**

B04C 5/26 (2006.01)
B01D 45/16 (2006.01)
B01D 45/08 (2006.01)
A47L 9/10 (2006.01)
A47L 9/12 (2006.01)
A47L 5/28 (2006.01)
B04C 5/185 (2006.01)
B04C 5/187 (2006.01)
B01D 46/24 (2006.01)
B01D 50/00 (2006.01)
B01D 46/00 (2006.01)

(52) **U.S. Cl.**

CPC **A47L 9/165** (2013.01); **A47L 9/1625** (2013.01); **A47L 9/1641** (2013.01); **A47L 9/1658** (2013.01); **A47L 9/1666** (2013.01); **A47L 9/1683** (2013.01); **B01D 45/08** (2013.01); **B01D 45/12** (2013.01); **B01D 45/16** (2013.01); **B04C 5/26** (2013.01); **B01D 46/0005** (2013.01); **B01D 46/2411** (2013.01); **B01D 50/002** (2013.01); **B04C 5/185** (2013.01); **B04C 5/187** (2013.01)

(58) **Field of Classification Search**

CPC **A47L 9/1608**; **B04C 5/185**; **B04C 5/26**; **B04C 5/28**; **B01D 45/16**; **B01D 50/002**; **B01D 45/12**

See application file for complete search history.

(56)

References Cited

U.S. PATENT DOCUMENTS

3,425,192 A 2/1969 Davis
 3,969,096 A 7/1976 Richard
 4,235,363 A 11/1980 Liller et al.
 4,820,414 A 4/1989 Carroll et al.
 6,334,234 B1 1/2002 Conrad et al.
 6,341,404 B1 1/2002 Salo et al.
 6,599,348 B2 7/2003 Chosnek et al.
 7,065,826 B1 6/2006 Arnold
 7,335,242 B2 2/2008 Oh
 7,488,362 B2 2/2009 Jeong et al.
 7,494,523 B2 2/2009 Oh et al.
 7,540,894 B2 6/2009 Ni
 7,645,309 B2 1/2010 Jeong et al.
 7,651,544 B1 1/2010 Fester et al.
 7,803,207 B2 9/2010 Conrad
 7,857,878 B2 12/2010 Park et al.
 7,867,308 B2 1/2011 Conrad
 7,887,612 B2 2/2011 Conrad
 7,931,716 B2 4/2011 Oakham
 7,951,218 B2 5/2011 Oh
 8,192,515 B2 6/2012 Conrad
 8,282,697 B2 10/2012 Oh
 8,607,407 B2 12/2013 Conrad
 8,657,932 B2 2/2014 Huziwarra et al.
 9,066,643 B2 6/2015 Conrad
 9,211,046 B2 12/2015 Peace
 9,629,511 B2 4/2017 Conrad
 2002/0088079 A1 7/2002 Oh
 2002/0116907 A1 8/2002 Gammack et al.
 2004/0112022 A1 6/2004 Vuijk
 2005/0252179 A1 11/2005 Oh et al.

2006/0123590 A1 6/2006 Fester et al.
 2006/0137304 A1 6/2006 Jeong et al.
 2006/0137309 A1 6/2006 Jeong et al.
 2006/0168923 A1 8/2006 Lee et al.
 2006/0207231 A1 9/2006 Arnold
 2006/0230715 A1 10/2006 Oh et al.
 2006/0230717 A1 10/2006 Oh et al.
 2006/0230720 A1 10/2006 Han et al.
 2006/0254226 A1 11/2006 Jeon
 2006/0286499 A1 12/2006 Kim
 2007/0011999 A1 1/2007 Oh
 2007/0079581 A1 4/2007 Kim et al.
 2007/0079582 A1 4/2007 Oh
 2007/0079583 A1 4/2007 Oh
 2007/0079584 A1 4/2007 Kim et al.
 2007/0079585 A1 4/2007 Oh et al.
 2007/0079587 A1 4/2007 Kim
 2007/0084160 A1 4/2007 Kim
 2007/0095030 A1 5/2007 Oh
 2007/0214756 A1 9/2007 Lee
 2008/0104795 A1 5/2008 Lang
 2008/0172995 A1 7/2008 Conrad
 2008/0184893 A1 8/2008 Oh et al.
 2008/0209869 A1 9/2008 Rother et al.
 2008/0289139 A1 11/2008 Makarov et al.
 2009/0100633 A1 4/2009 Bates et al.
 2009/0113663 A1 5/2009 Follows et al.
 2009/0181841 A1 7/2009 Conrad
 2009/0193771 A1 8/2009 Oh et al.
 2009/0241491 A1 10/2009 Han et al.
 2009/0300872 A1 12/2009 Griffith et al.
 2010/0132316 A1 6/2010 Ni
 2010/0139033 A1 6/2010 Makarov et al.
 2010/0251506 A1 10/2010 Conrad
 2010/0251507 A1 10/2010 Conrad
 2012/0036675 A1 2/2012 Conrad
 2012/0047682 A1* 3/2012 Makarov A47L 9/1683
 15/347

2012/0167336 A1 7/2012 Tran et al.
 2012/0210537 A1 8/2012 Makarov et al.
 2012/0222251 A1 9/2012 Conrad
 2012/0222252 A1 9/2012 Conrad
 2012/0222257 A1 9/2012 Conrad
 2013/0055691 A1 3/2013 Kim et al.
 2013/0091660 A1 4/2013 Smith
 2013/0091661 A1 4/2013 Smith
 2013/0091812 A1 4/2013 Smith
 2013/0091813 A1 4/2013 Smith
 2013/0118960 A1 5/2013 Tandon
 2013/0152796 A1 6/2013 Pawl
 2013/0227813 A1 9/2013 Conrad
 2013/0232722 A1 9/2013 Conrad
 2013/0291334 A1 11/2013 Peng
 2014/0033662 A1 2/2014 Craig
 2014/0245566 A1 9/2014 Conrad
 2015/0182085 A1 7/2015 Tran et al.
 2015/0223657 A1 8/2015 Choe et al.
 2015/0359394 A1 12/2015 Peace

FOREIGN PATENT DOCUMENTS

CN 1875855 A 12/2006
 CN 1887437 A 1/2007
 CN 1969739 A 5/2007
 CN 100998484 A 7/2007
 CN 101108081 A 1/2008
 CN 101108111 A 1/2008
 CN 201008534 Y 1/2008
 CN 201131706 A 1/2008
 CN 101612025 A 12/2009
 CN 202277306 U 6/2012
 DE 60201666 T2 6/2006
 DE 202006017010 U1 2/2007
 DE 60211663 T2 5/2007
 DE 102004028678 B4 9/2007
 DE 102007011457 A1 10/2007
 DE 102004055192 B4 11/2007
 DE 102006027456 A1 12/2007
 DE 102004028677 B4 1/2008

(56)

References Cited

FOREIGN PATENT DOCUMENTS

DE	102005015004	B4	2/2008
DE	102005008278	B4	3/2008
DE	102006055099	A1	5/2008
DE	102005014541	B4	8/2008
DE	112006003479	T5	12/2008
DE	112007001314	T5	4/2009
DE	602006000726	T2	4/2009
DE	102008055045	A	6/2010
DE	112011104642	T5	10/2013
DE	112012000251	T5	10/2013
DE	202010018047	U1	11/2013
DE	202010018084	U1	2/2014
DE	202010018085	U1	2/2014
GB	2454292	A	5/2009
JP	08322769	A	12/1996
JP	2005342334	A	12/2005
KR	1020010024752	A	3/2001
KR	1020050108623	A	11/2005
KR	1020060008365	A	1/2006
KR	1020060081229	A	7/2006
KR	1020060118800	A	11/2006
KR	1020060118801	A	11/2006
KR	1020060122249	A	11/2006
KR	1020060122521	A	11/2006
KR	1020060125952	A	12/2006
KR	1020080039105	A	5/2008
WO	2008034325	A1	3/2008
WO	2008065168	A1	6/2008

OTHER PUBLICATIONS

TotalPatent: English translation of CN1875855, as published on Dec. 13, 2006.

TotalPatent: English translation of CN1969739, as published on May 30, 2007.

TotalPatent: English translation of CN100998484, as published on Jul. 18, 2007.

TotalPatent: English translation of CN101108081, as published on Jan. 23, 2008.

TotalPatent: English translation of CN101108111, as published on Jan. 23, 2008.

TotalPatent: English translation of CN101612025, as published on Dec. 30, 2009.

TotalPatent: English translation of CN201008534, as published on Jan. 23, 2008.

TotalPatent: English translation of CN201131706, as published on Oct. 15, 2008.

TotalPatent: English translation of CN202277306, as published on Jun. 20, 2012.

TotalPatent: English translation of DE60201666, as published on Jun. 1, 2006.

TotalPatent: English translation of DE60211663, as published on May 10, 2007.

TotalPatent: English translation of DE102004028677, as published on Jan. 10, 2008.

TotalPatent: English translation of DE102004028678, as published on Sep. 6, 2007.

TotalPatent: English translation of DE102004055192, as published on Nov. 15, 2007.

TotalPatent: English translation of DE102005008278, as published on Mar. 27, 2008.

TotalPatent: English translation of DE102005014541, as published on Aug. 28, 2008.

TotalPatent: English translation of DE102005015004, as published on Feb. 7, 2008.

TotalPatent: English translation of DE102006027456, as published on Dec. 13, 2007.

TotalPatent: English translation of DE102006055099, as published on May 29, 2008.

TotalPatent: English translation of DE102007011457, as published on Oct. 25, 2007.

TotalPatent: English translation of DE102008055045, as published on Jun. 24, 2010.

TotalPatent: English translation of DE112006003479, as published on Dec. 18, 2008.

TotalPatent: English translation of DE112007001314, as published on Apr. 23, 2009.

TotalPatent: English translation of DE112011104642, as published on Oct. 2, 2013.

TotalPatent: English translation of DE112012000251, as published on Oct. 17, 2013.

TotalPatent: English translation of DE202006017010, as published on Feb. 8, 2007.

TotalPatent: English translation of DE202010018047, as published on Nov. 14, 2013.

TotalPatent: English translation of DE202010018084, as published on Feb. 27, 2007.

TotalPatent: English translation of DE202010018085, as published on Feb. 27, 2007.

TotalPatent: English translation of DE602006000726, as published on Apr. 16, 2009.

TotalPatent: English translation of JP2005342334, as published on Dec. 15, 2005.

TotalPatent: English translation of KR1020010024752, as published on Mar. 26, 2001.

TotalPatent: English translation of KR1020050108623, as published on Nov. 17, 2005.

TotalPatent: English translation of KR1020060008365, as published on Jan. 26, 2006.

TotalPatent: English translation of KR1020060081229, as published on Jul. 12, 2006.

TotalPatent: English translation of KR1020060118800, as published on Nov. 24, 2006.

TotalPatent: English translation of KR1020060118801, as published on Nov. 24, 2006.

TotalPatent: English translation of KR1020060122249, as published on Nov. 30, 2006.

TotalPatent: English translation of KR1020060122521, as published on Nov. 30, 2006.

TotalPatent: English translation of KR1020060125952, as published on Dec. 7, 2006.

TotalPatent: English translation of KR1020080039105, as published on May 7, 2008.

TotalPatent: English machine translation of CN1729924A, as published on Feb. 8, 2006.

TotalPatent: English machine translation of CN1887437A, as published on Jan. 3, 2007.

Corrected Written Opinion of the International Searching Authority and International Search Report, received on PCT/CA2017/050505, dated Aug. 15, 2017.

International Search Report and the Written Opinion of the International Searching Authority, dated Aug. 15, 2017.

TotalPatent: English translation of JP08322769, as published on Dec. 10, 1996.

* cited by examiner

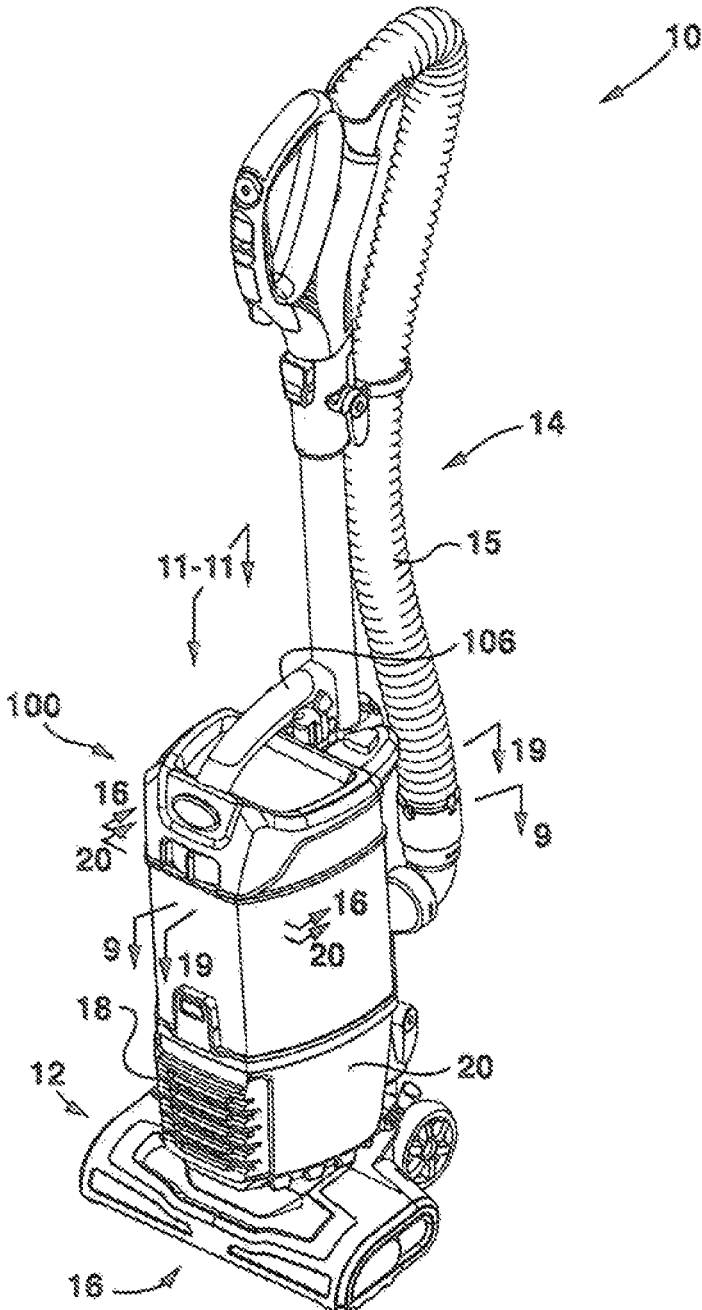

FIG. 1

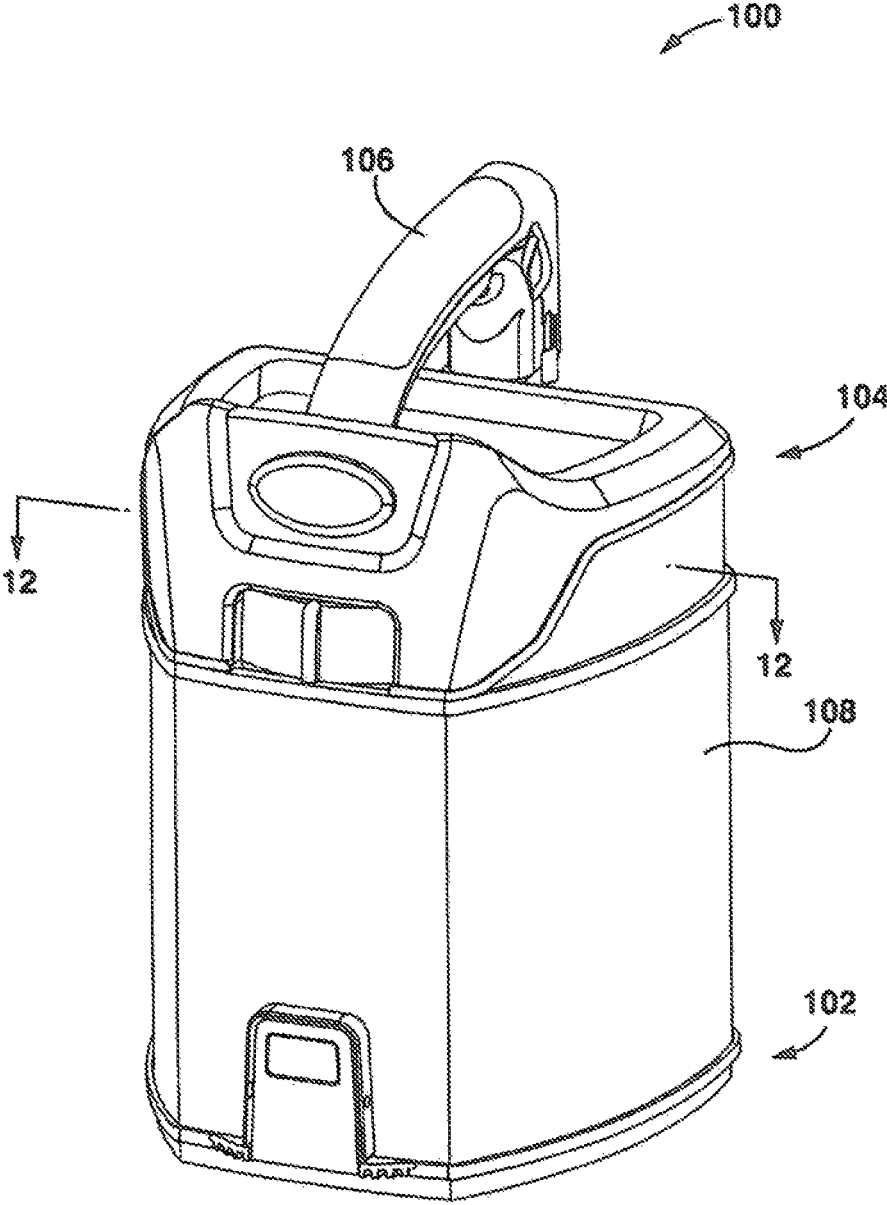

FIG. 2

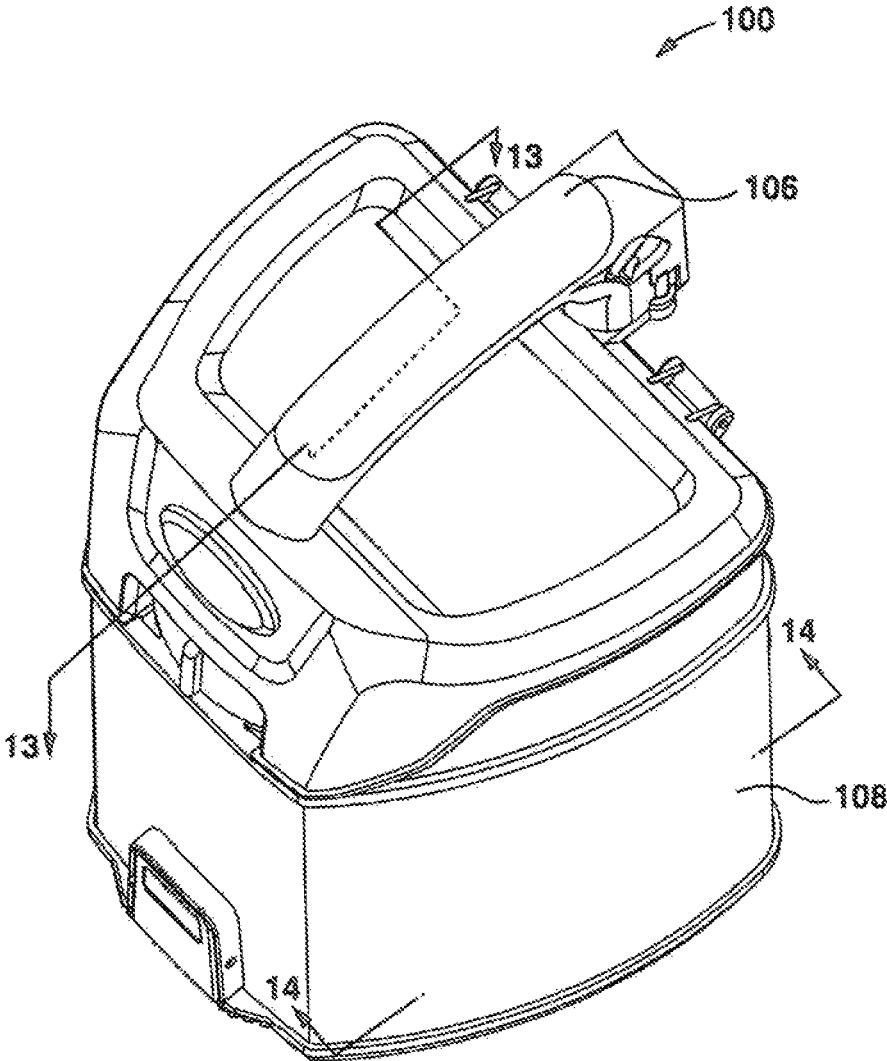

FIG. 3

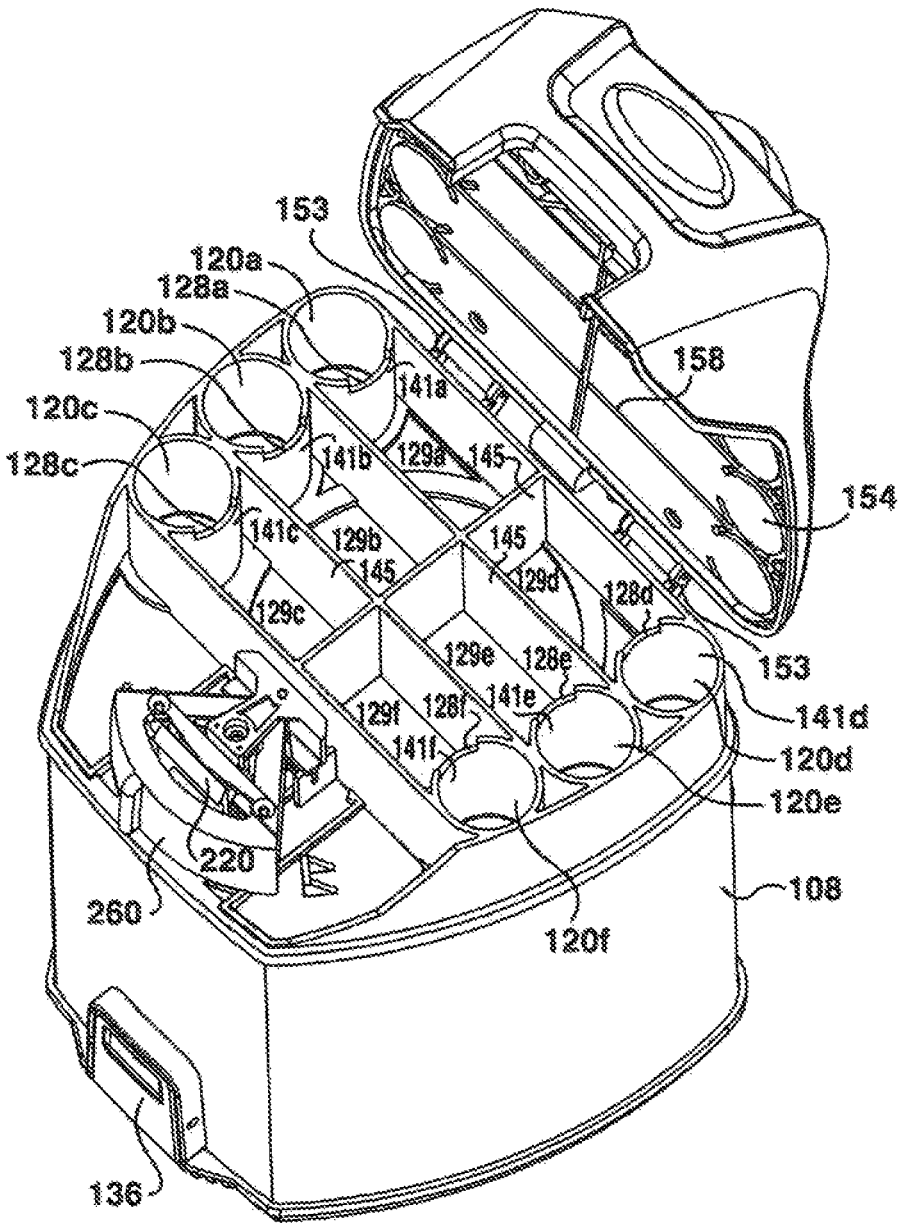

FIG. 4

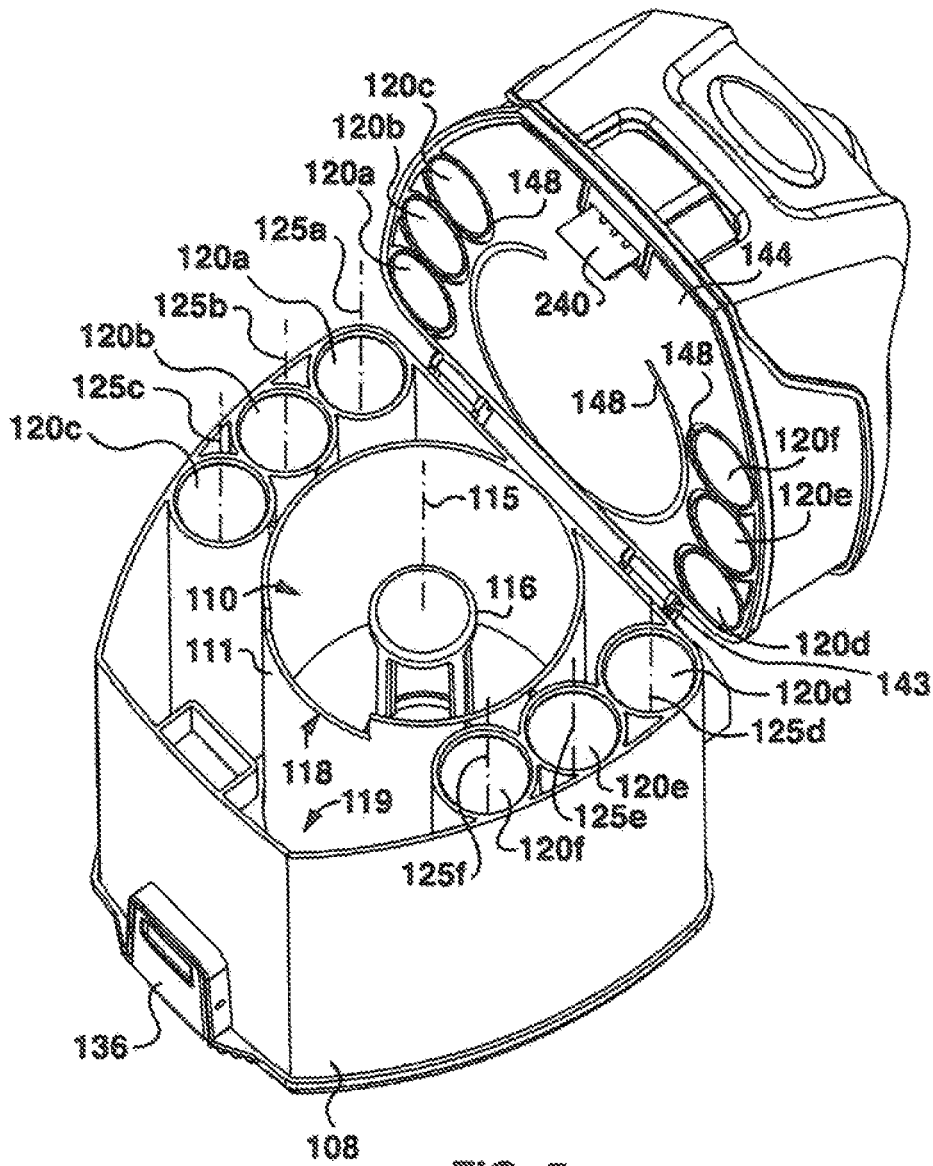

FIG. 5

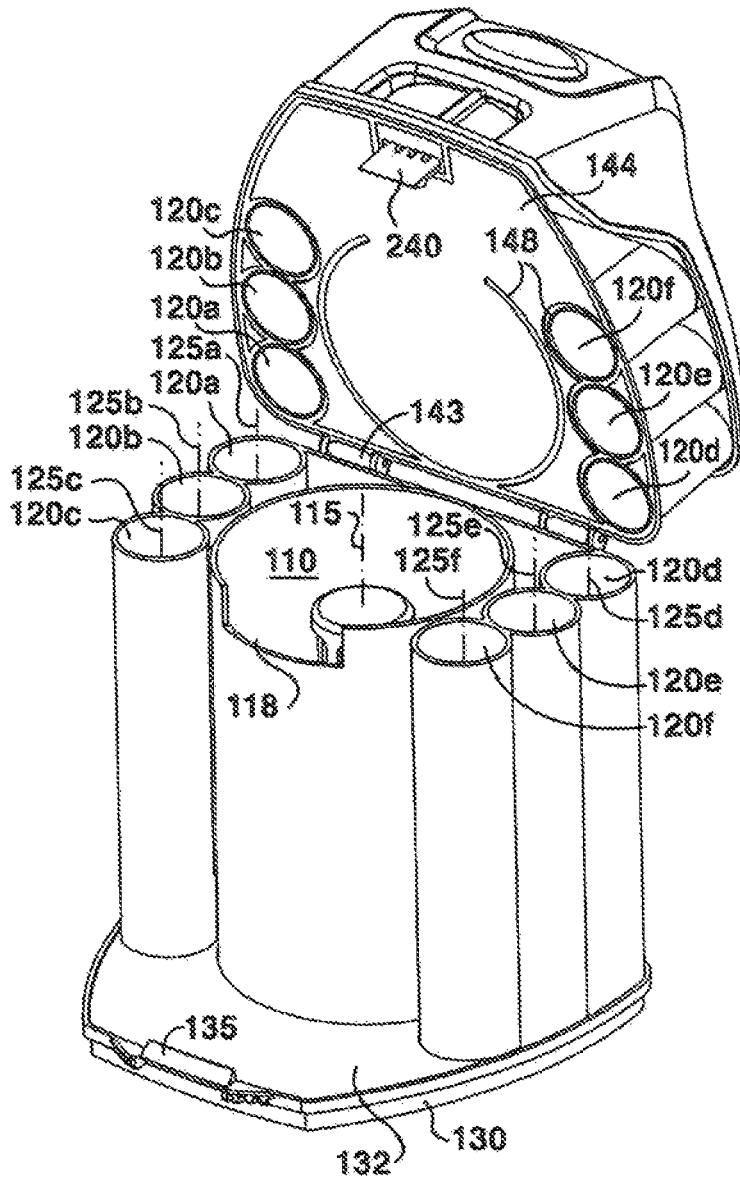

FIG. 6

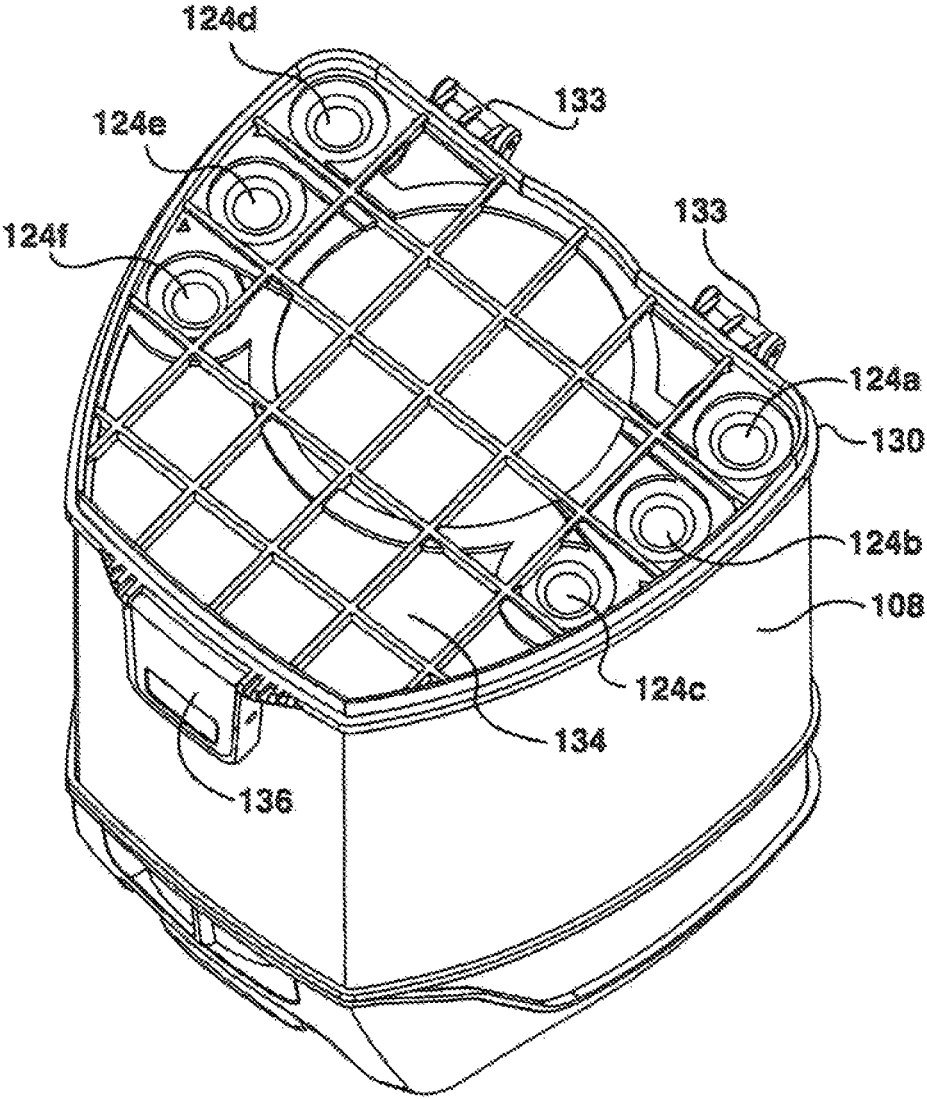

FIG. 7

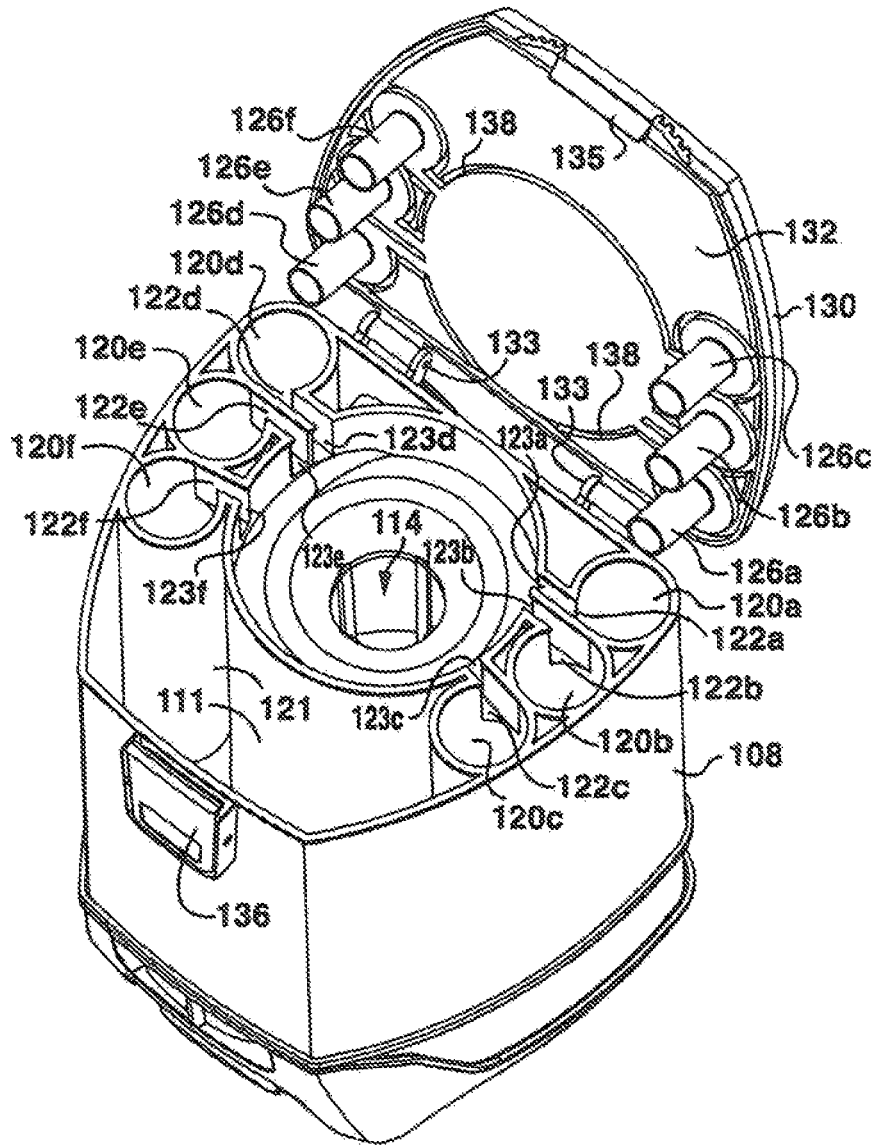

FIG. 8

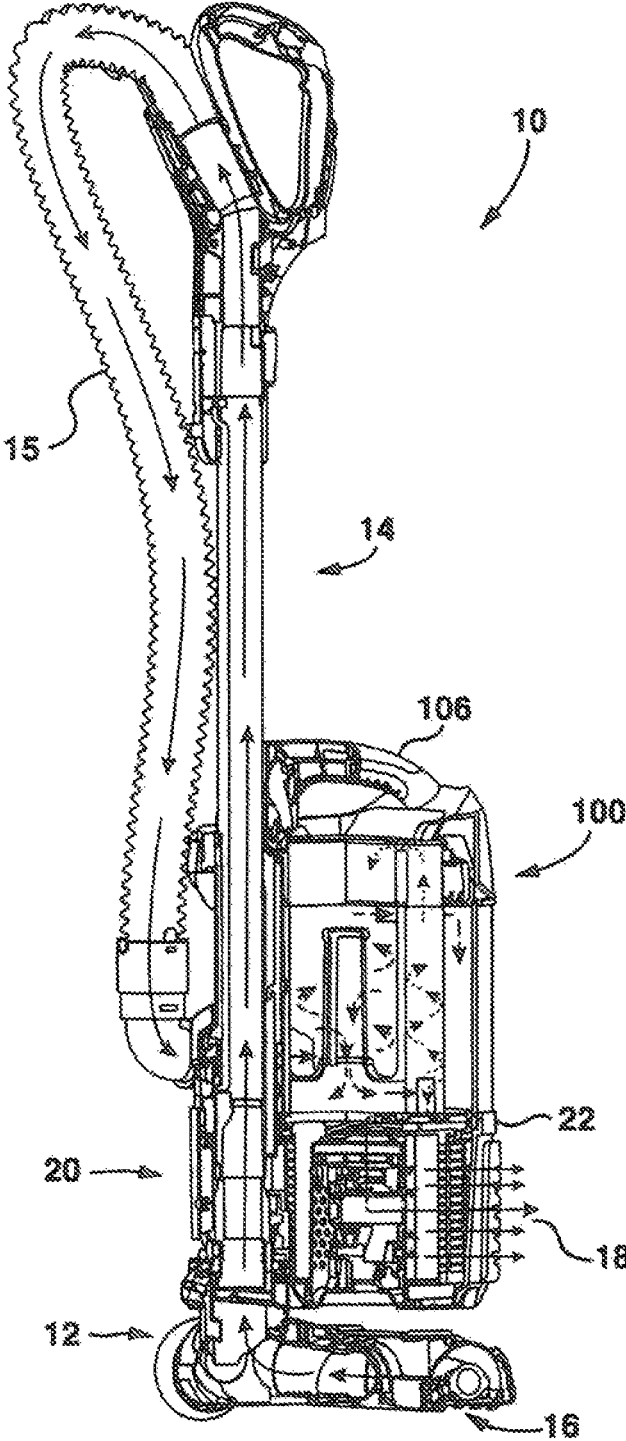

FIG. 9

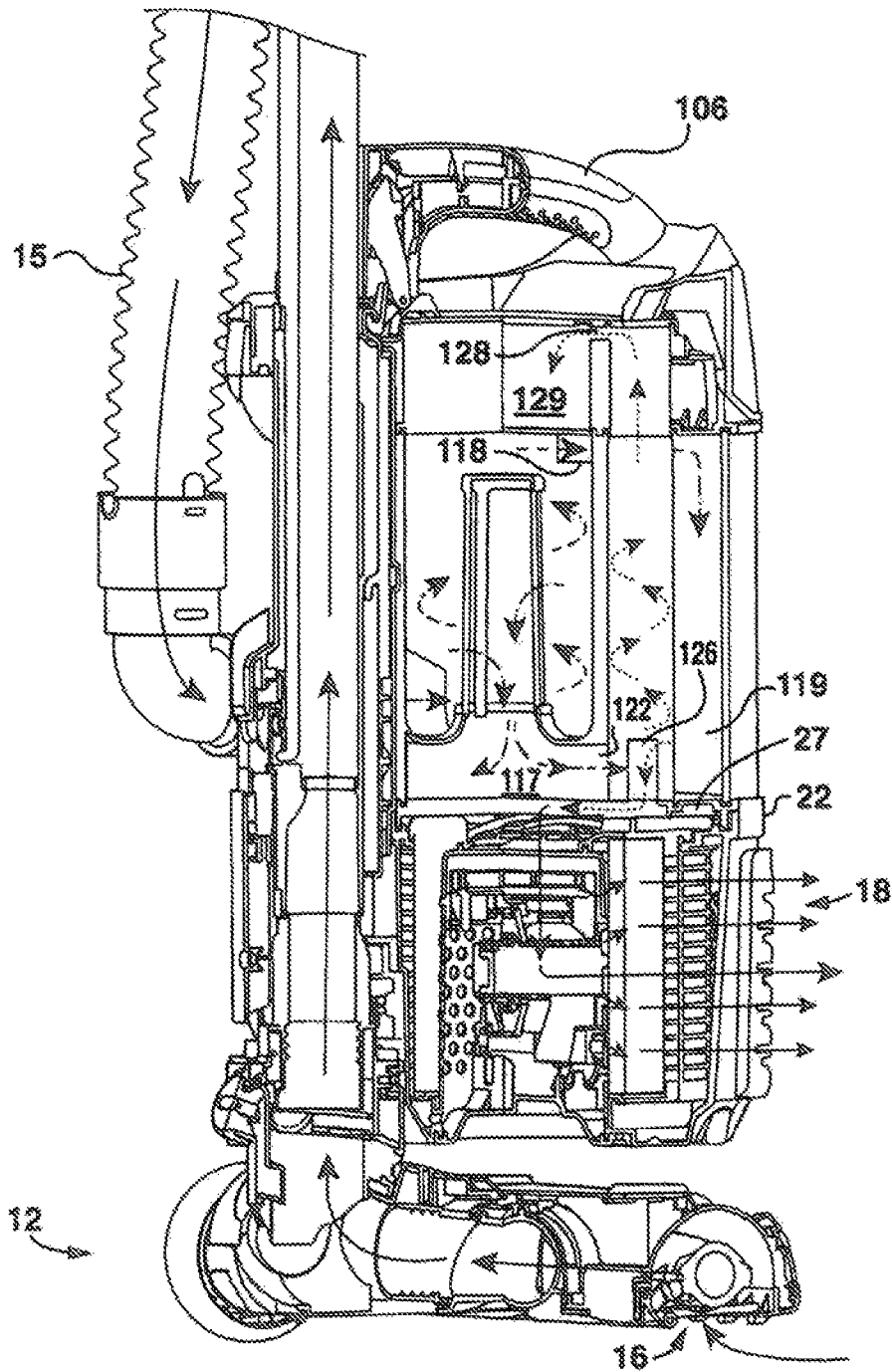

FIG. 10

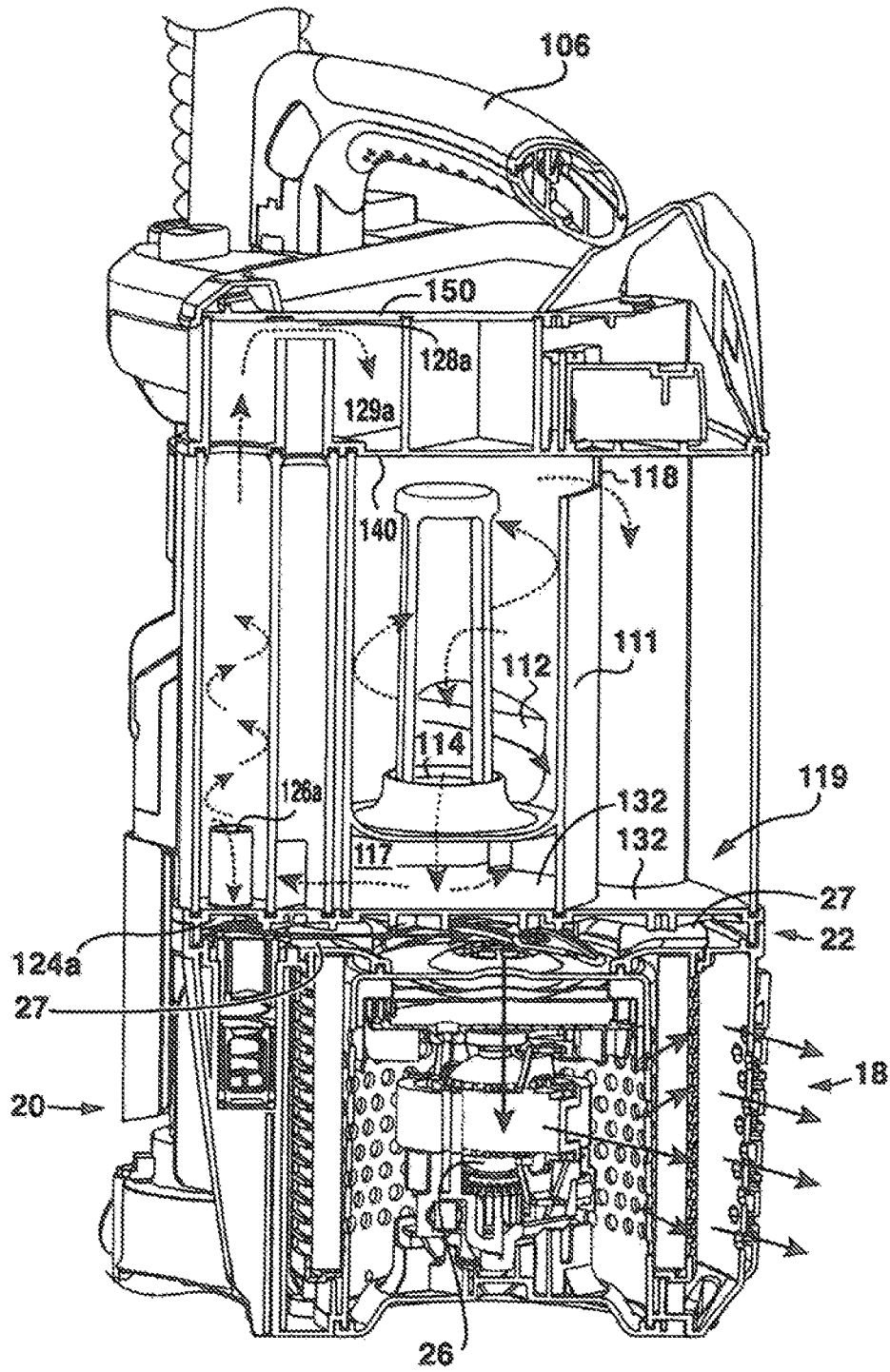

FIG. 11

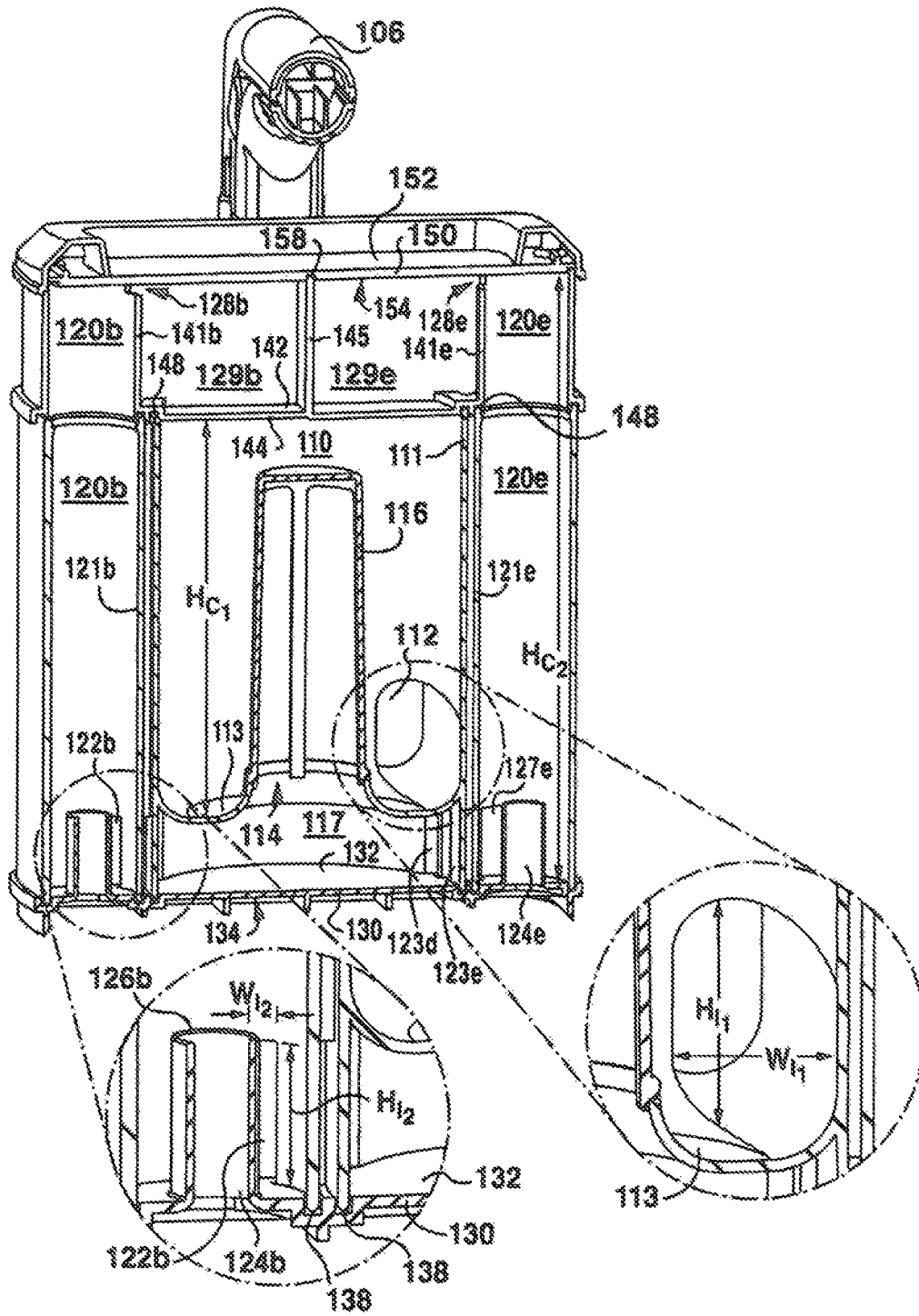

FIG. 12

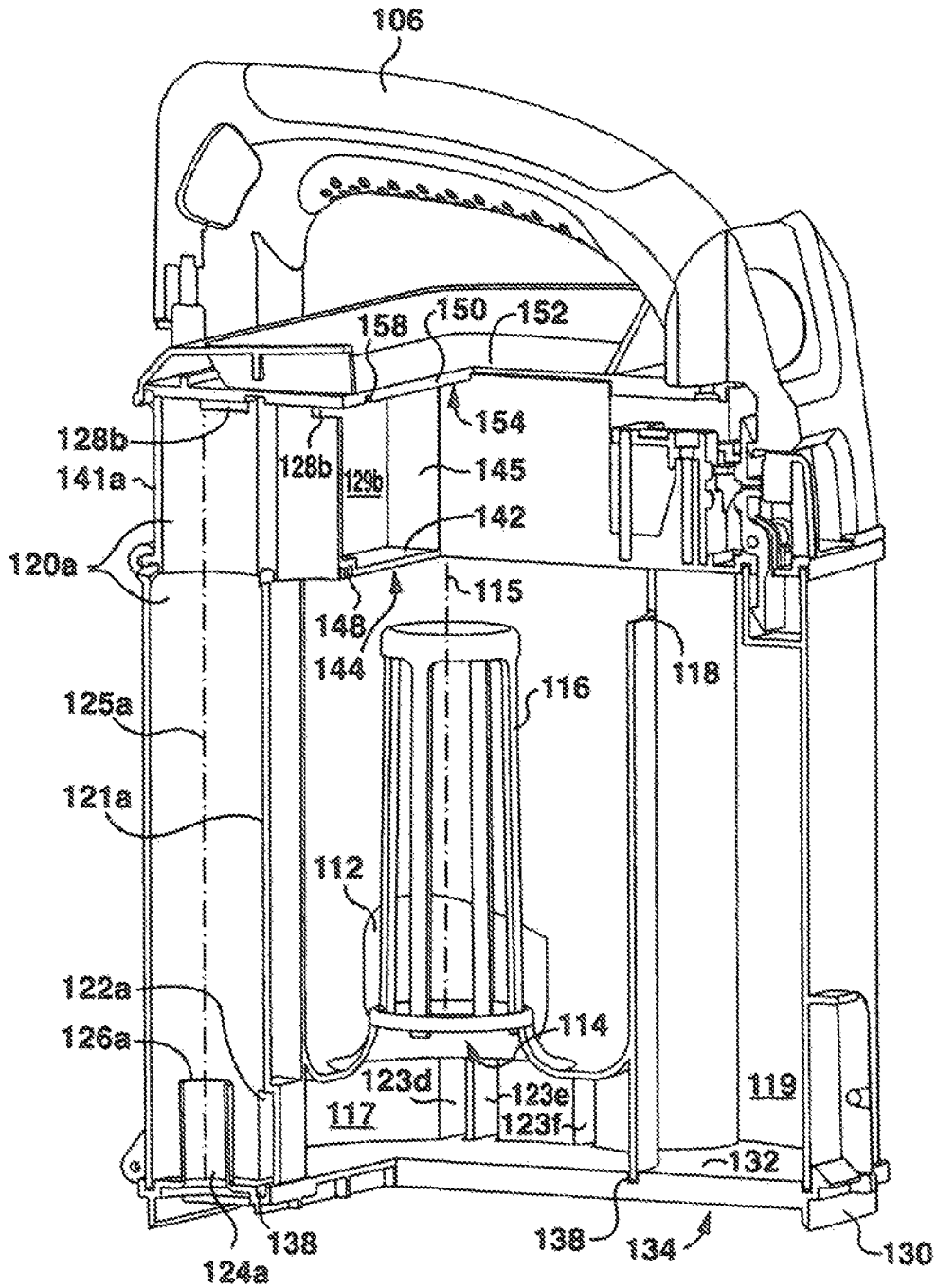

FIG. 13

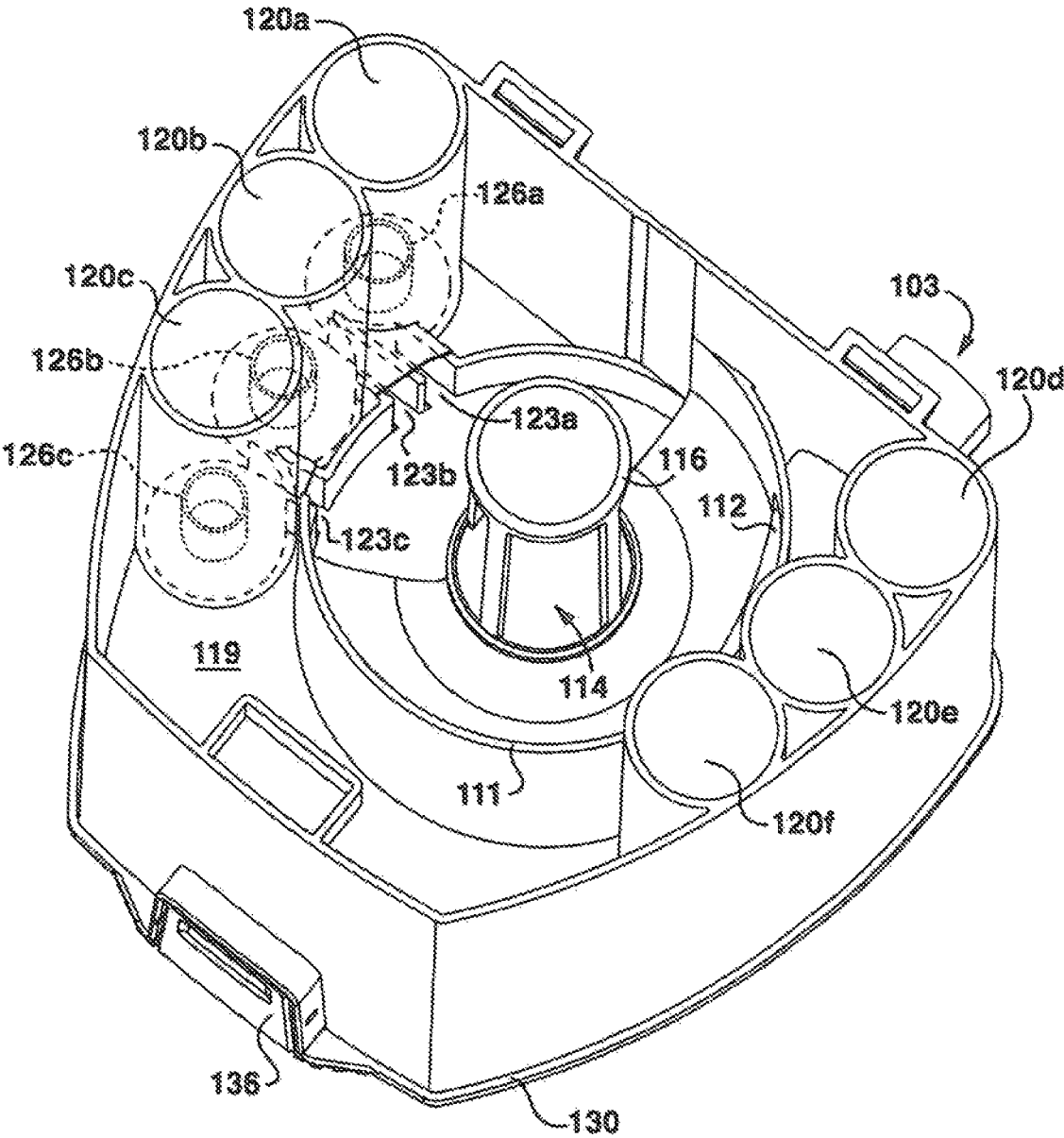

FIG. 14

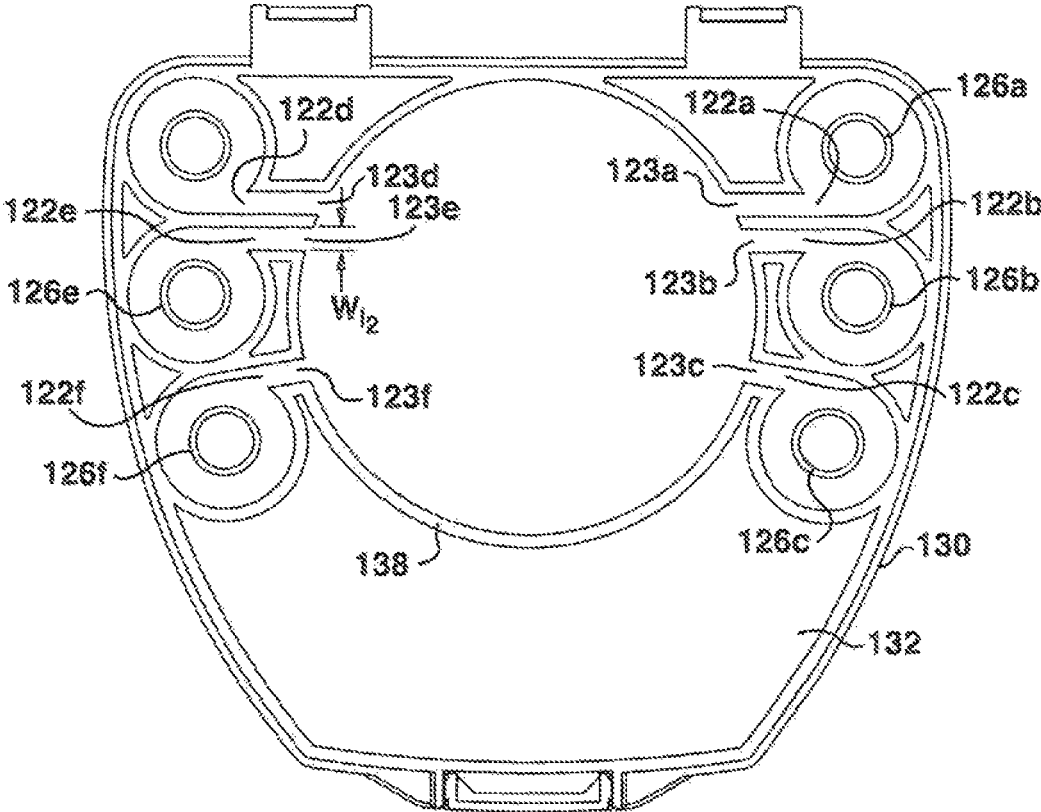

FIG. 15

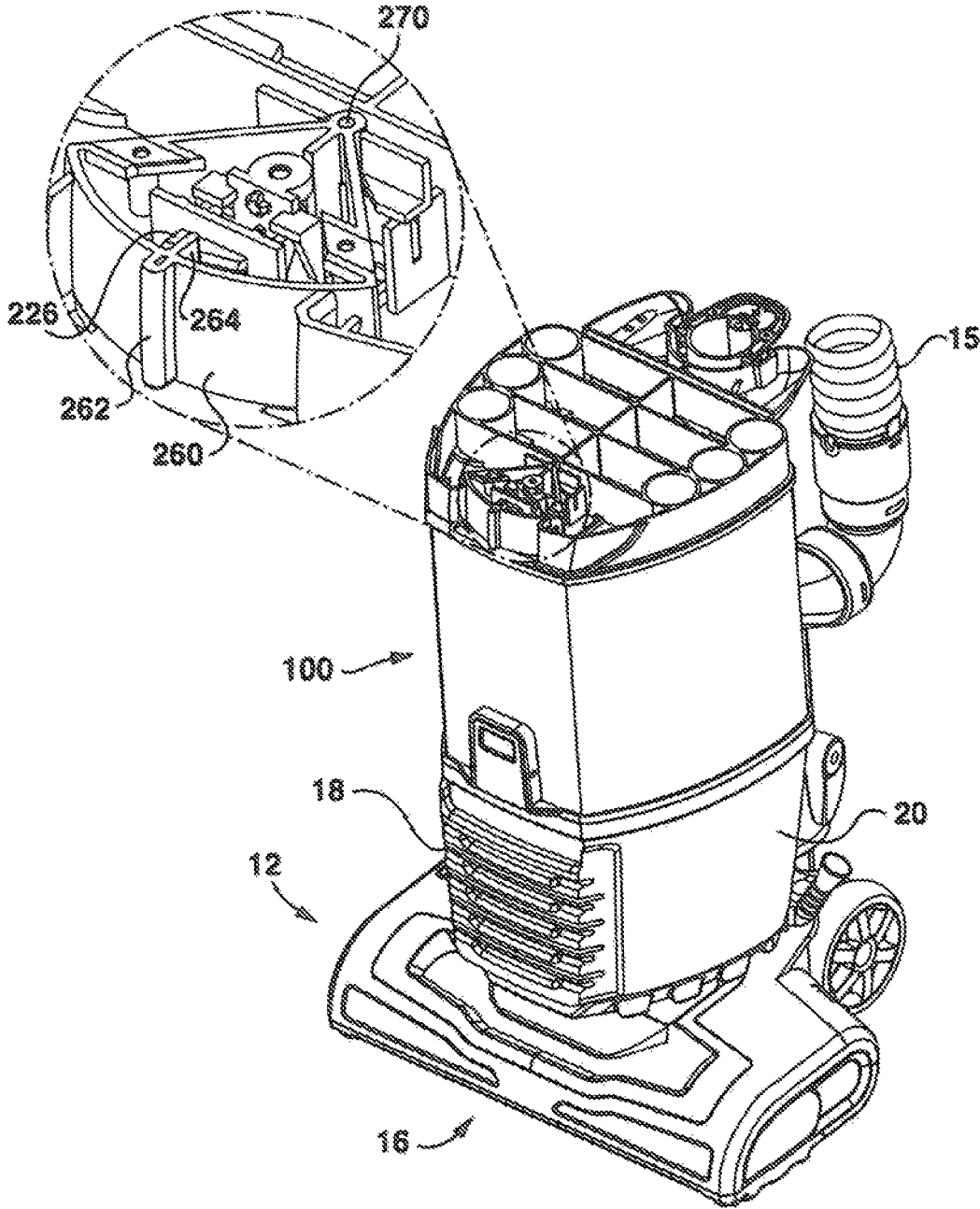

FIG. 16

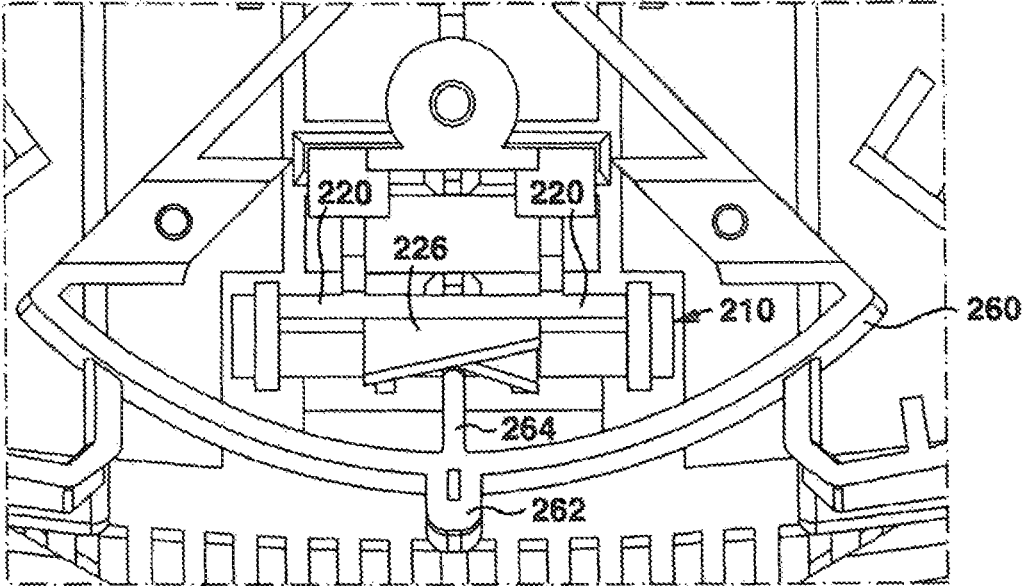

FIG. 17

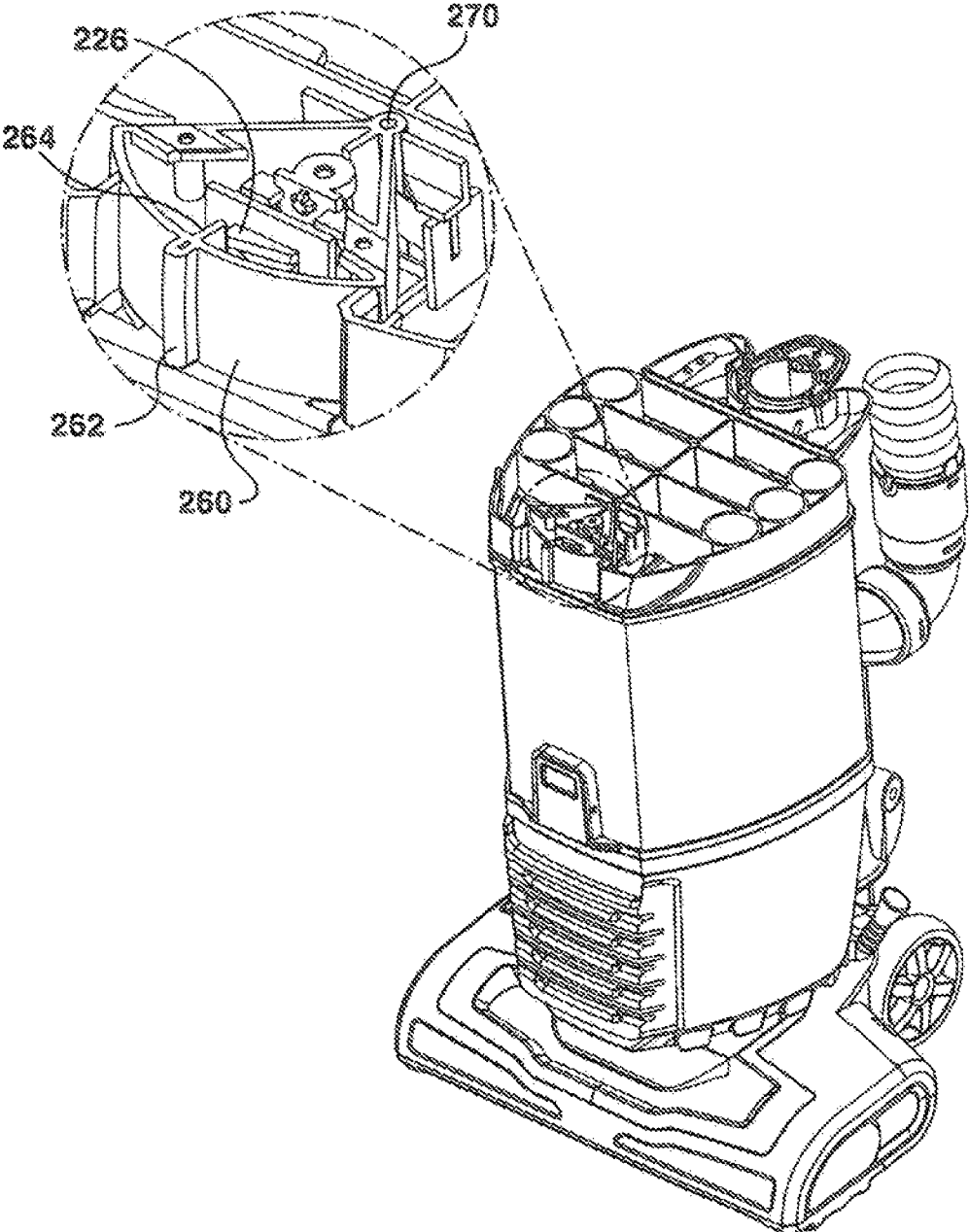

FIG. 18

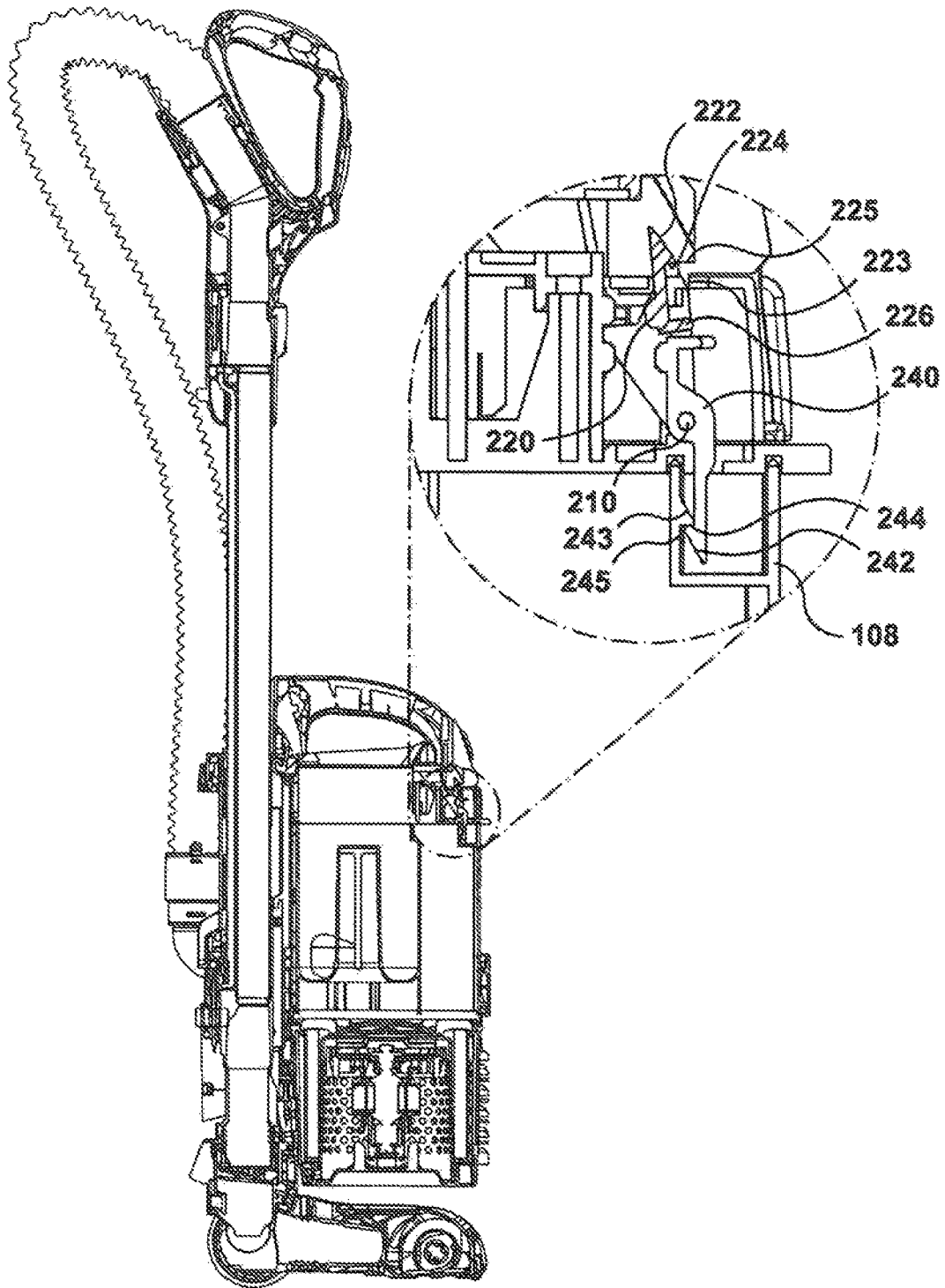

FIG. 19

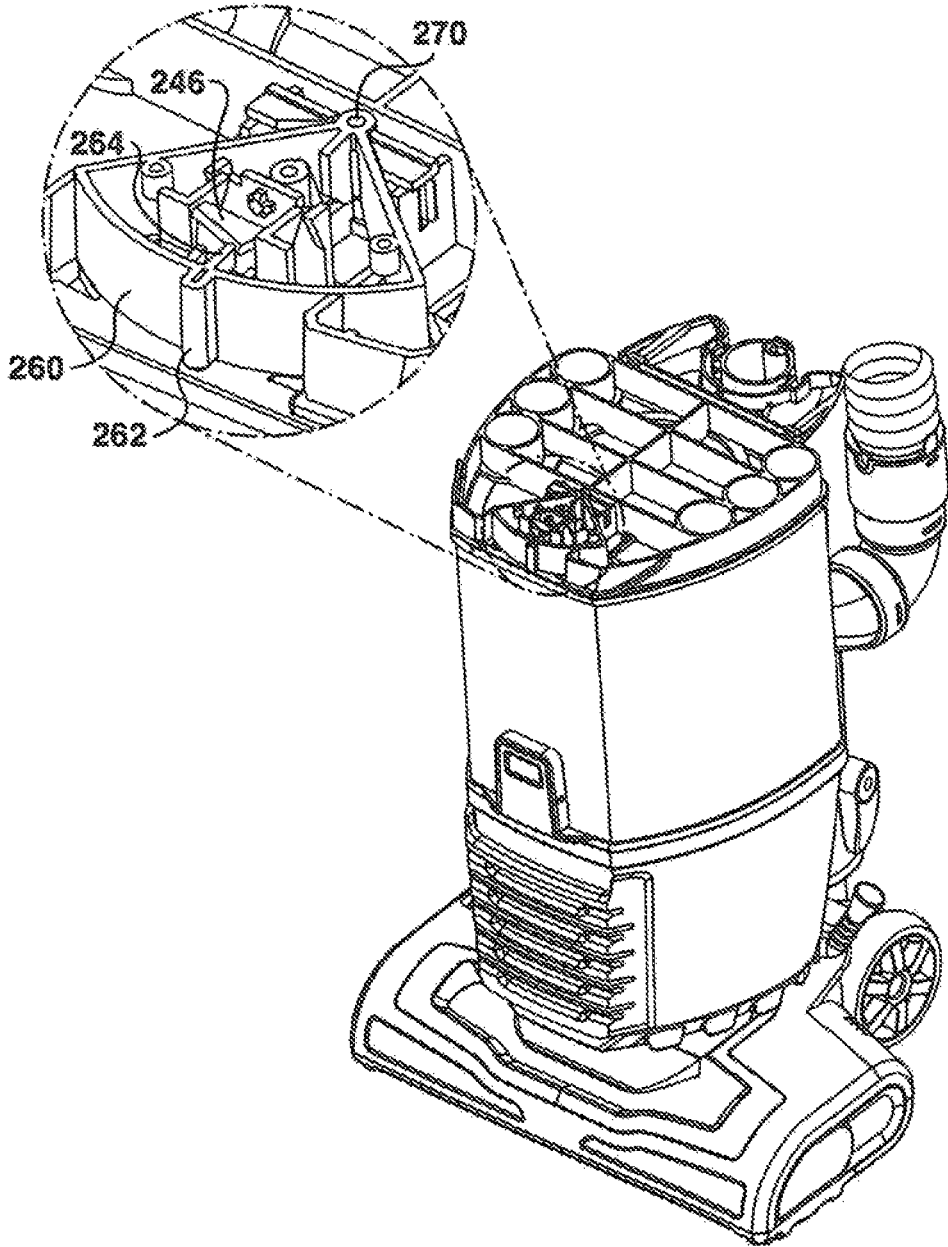

FIG. 20

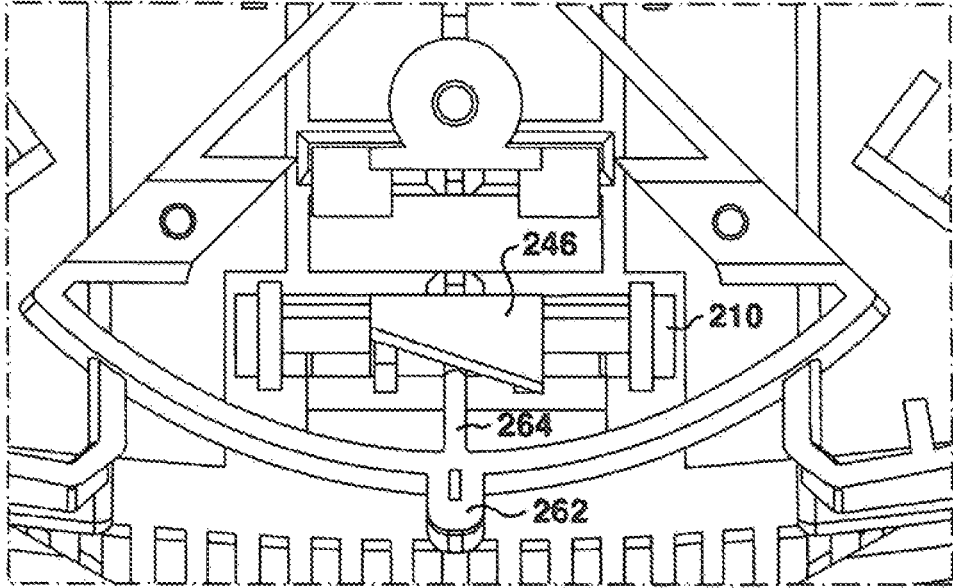

FIG. 21

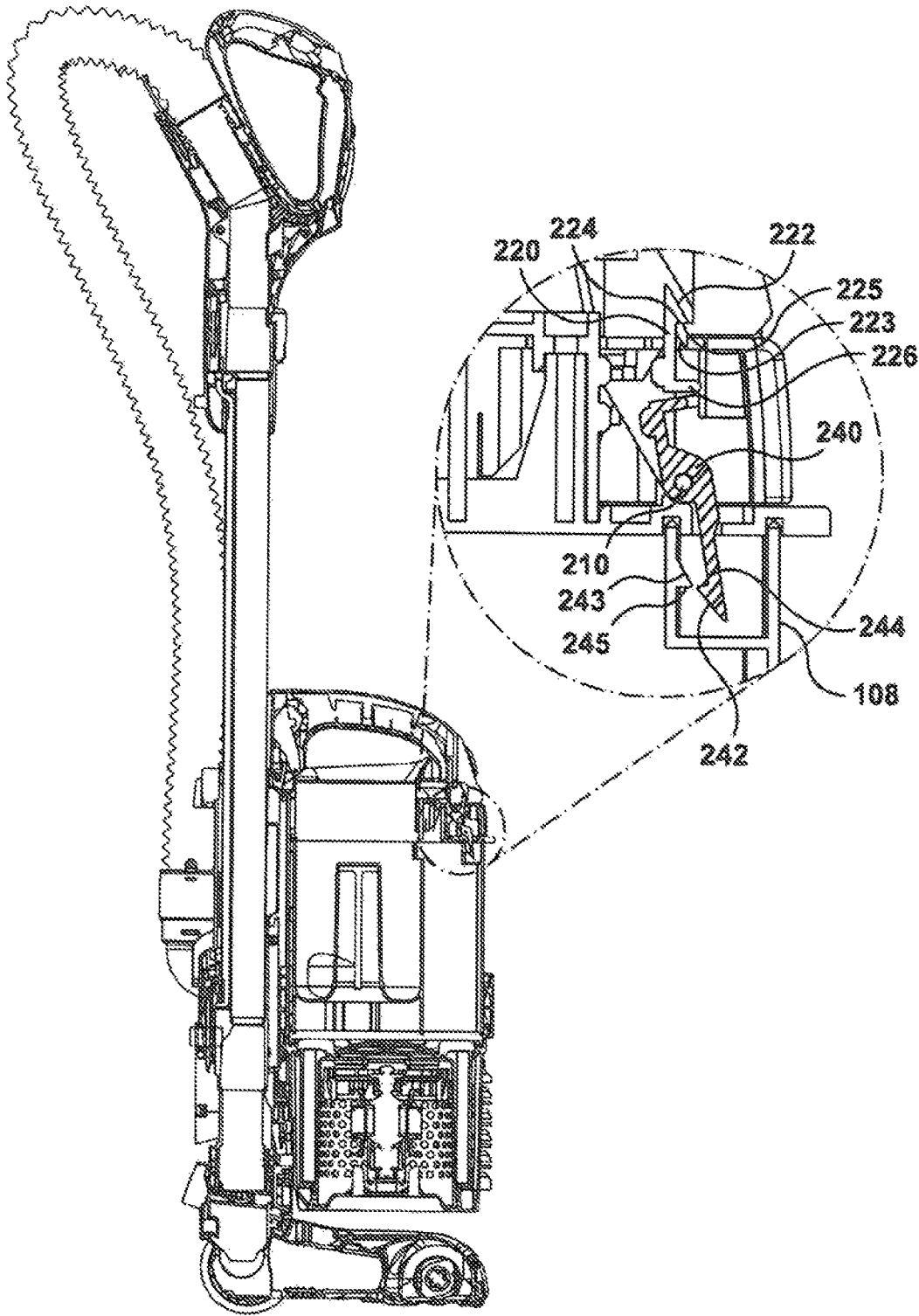

FIG. 22

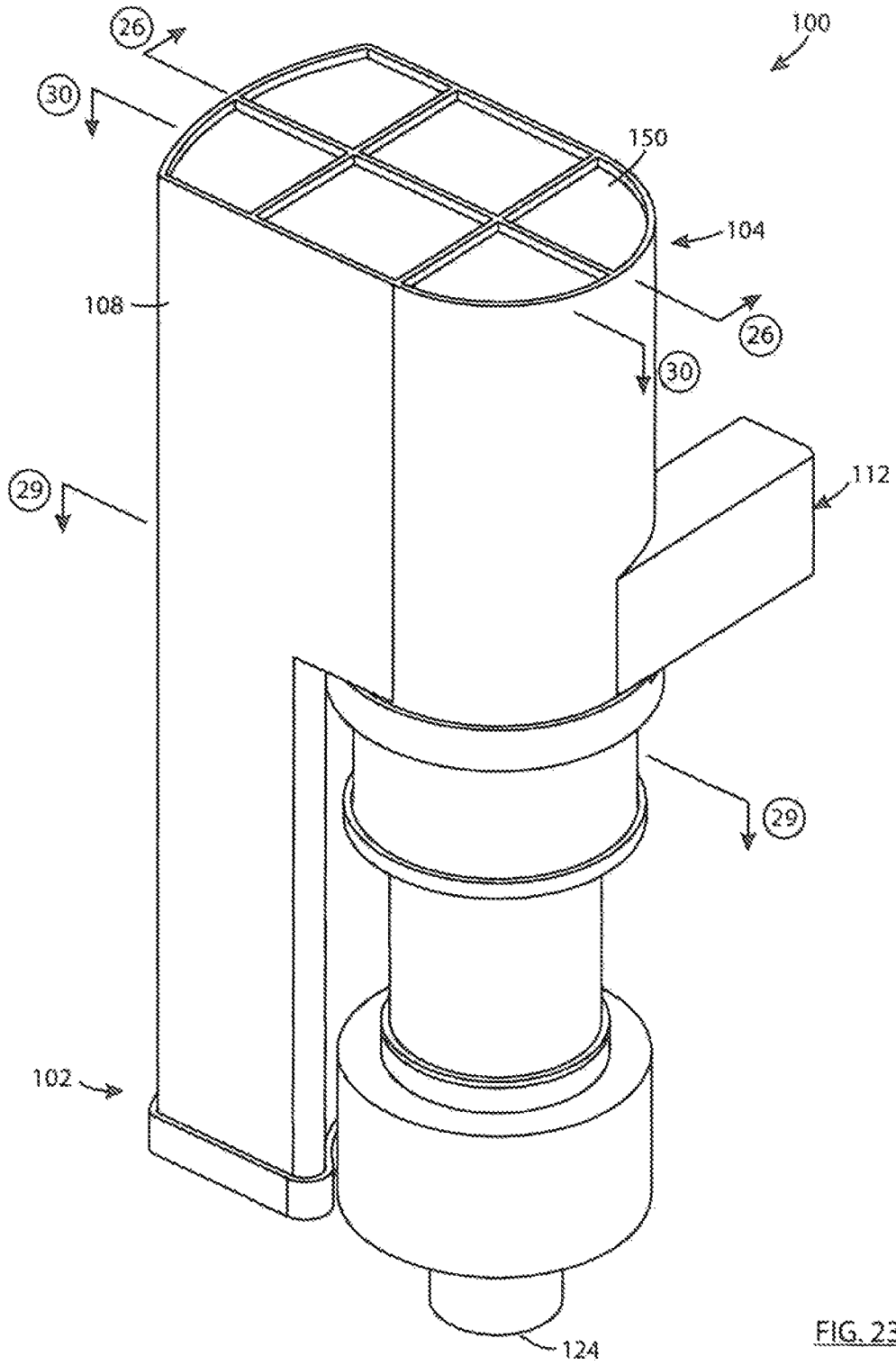

FIG. 23

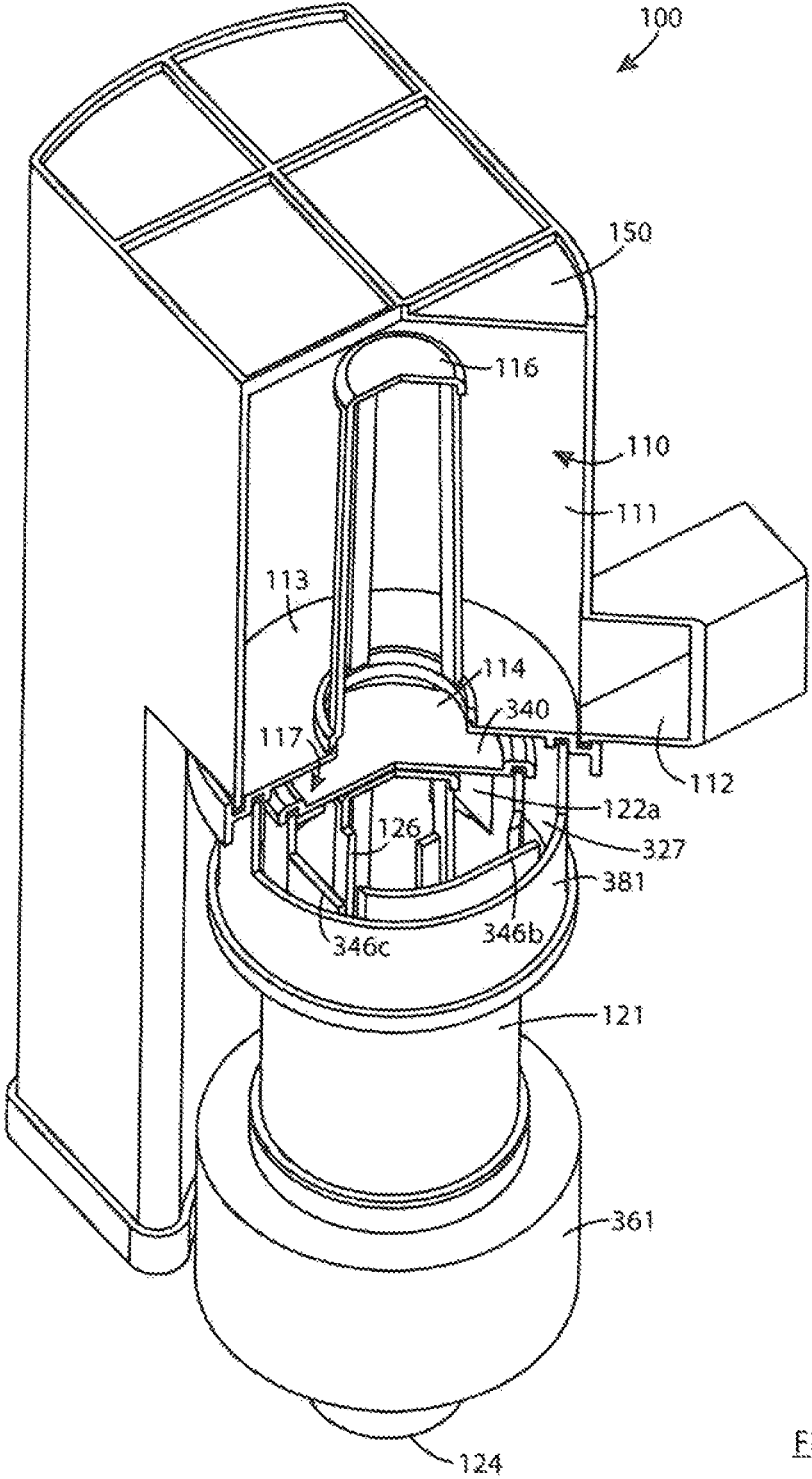

FIG. 24

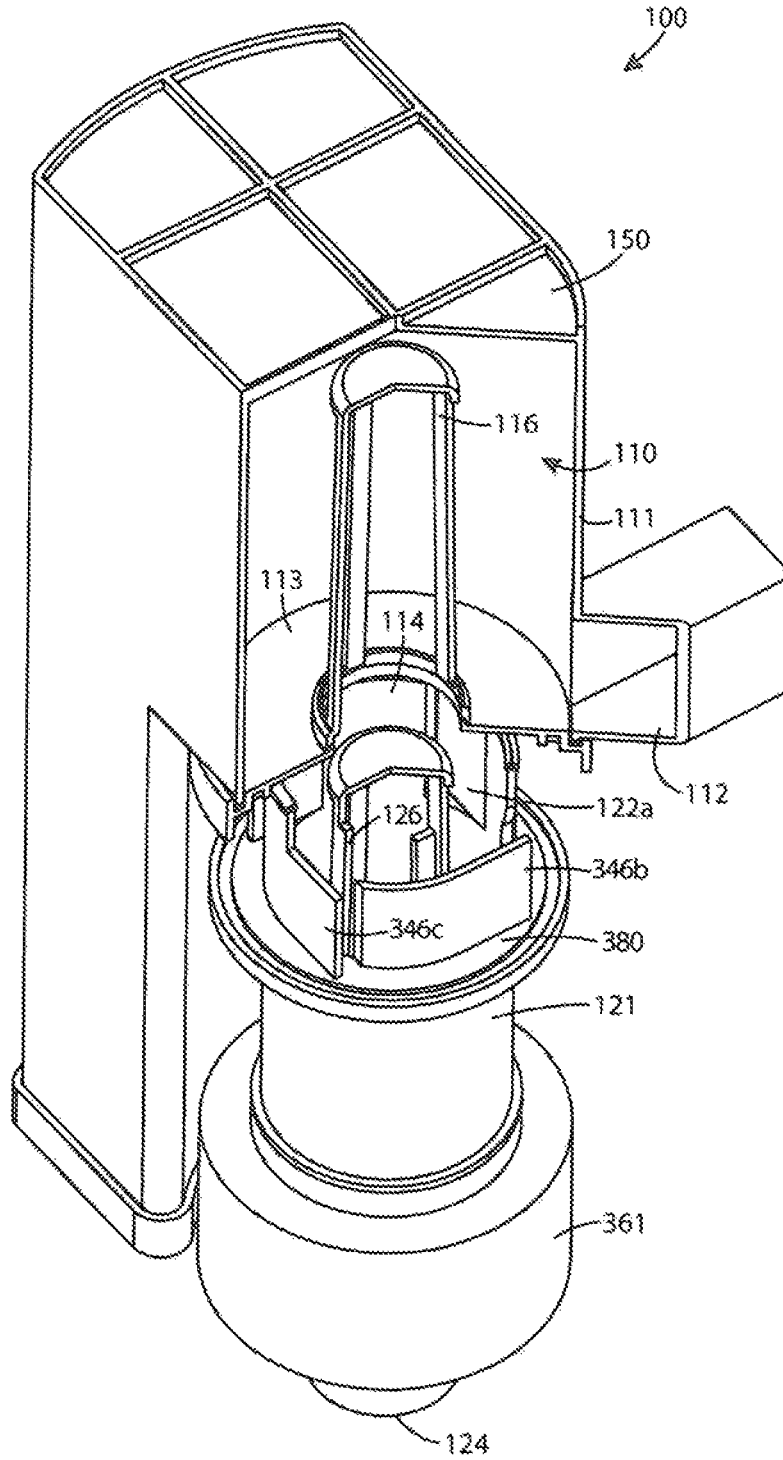

FIG. 25

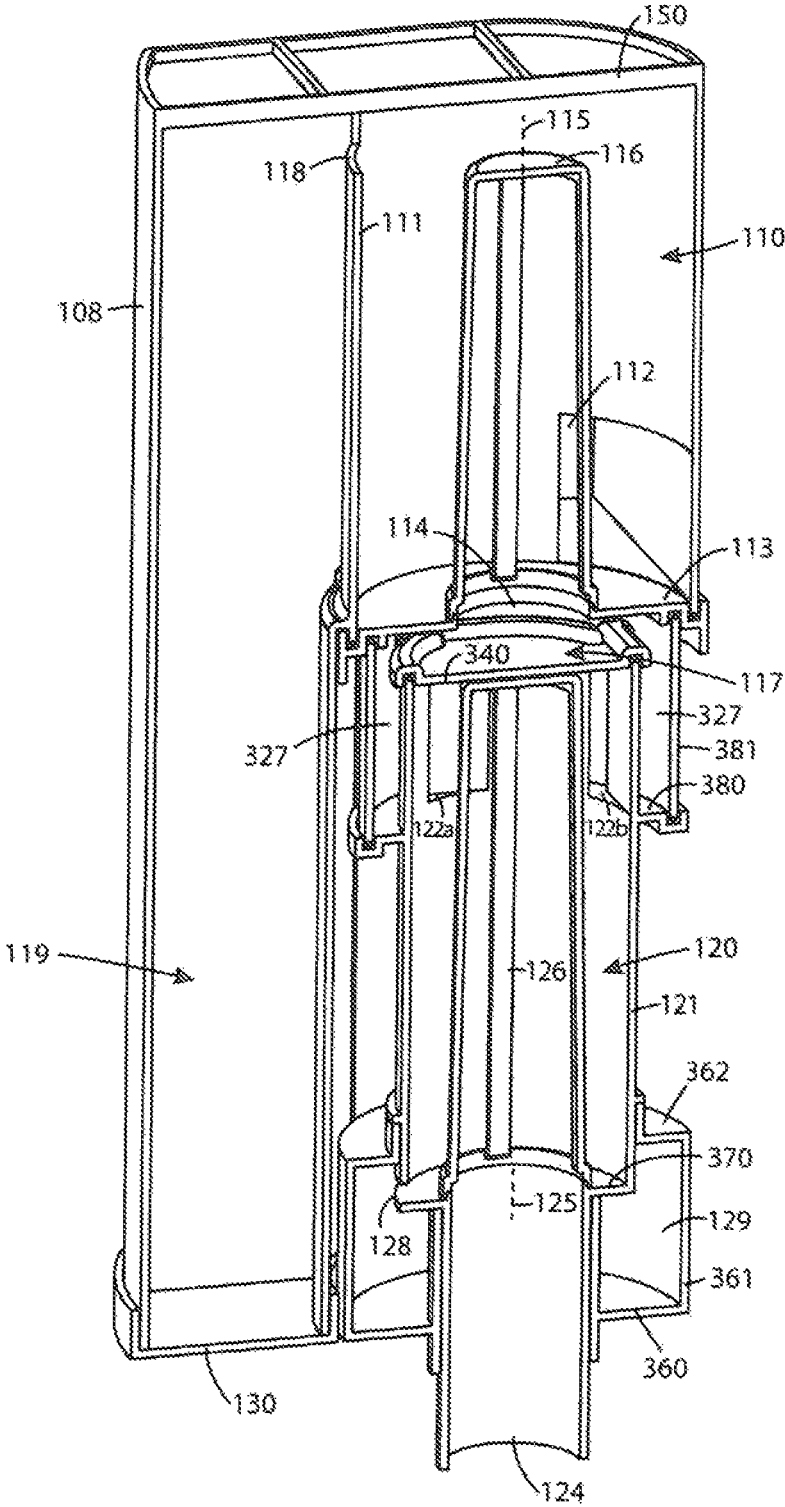

FIG. 26

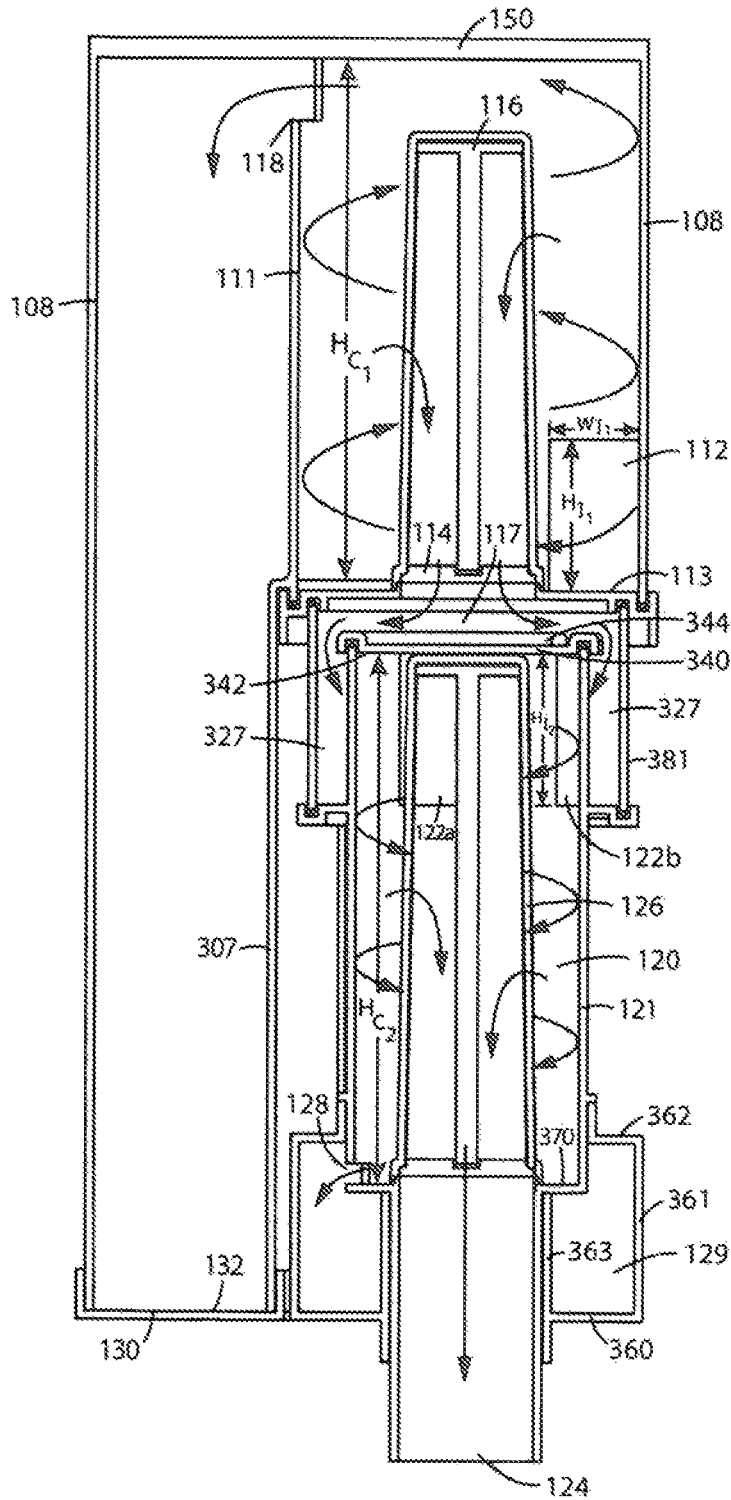

FIG. 27

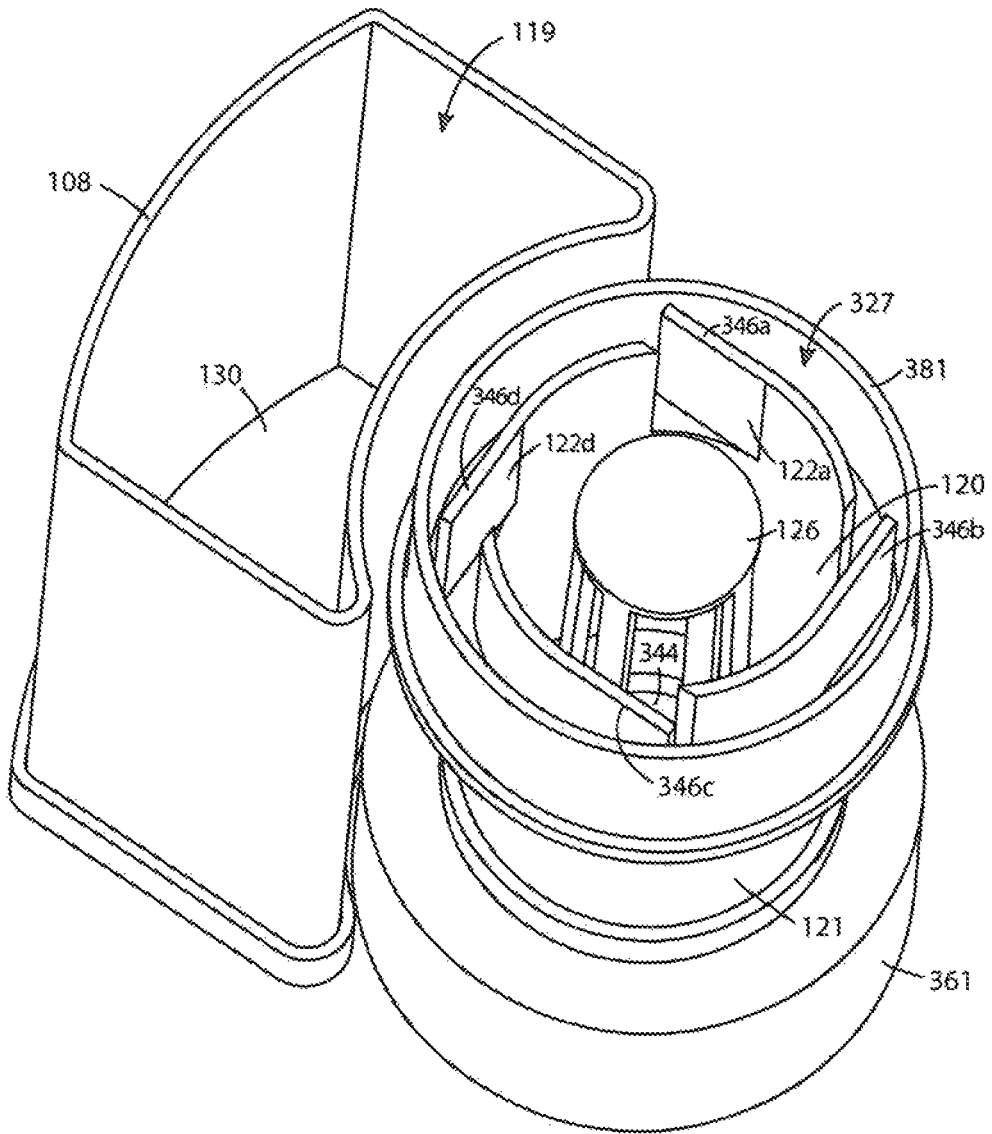

FIG. 28

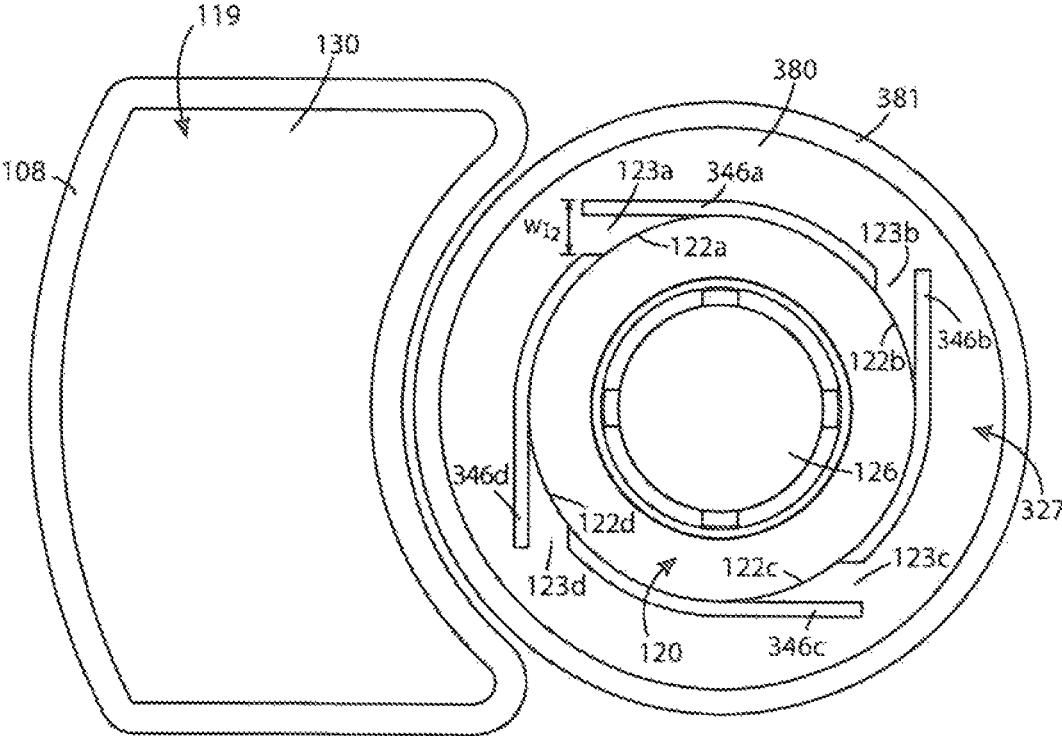

FIG. 29

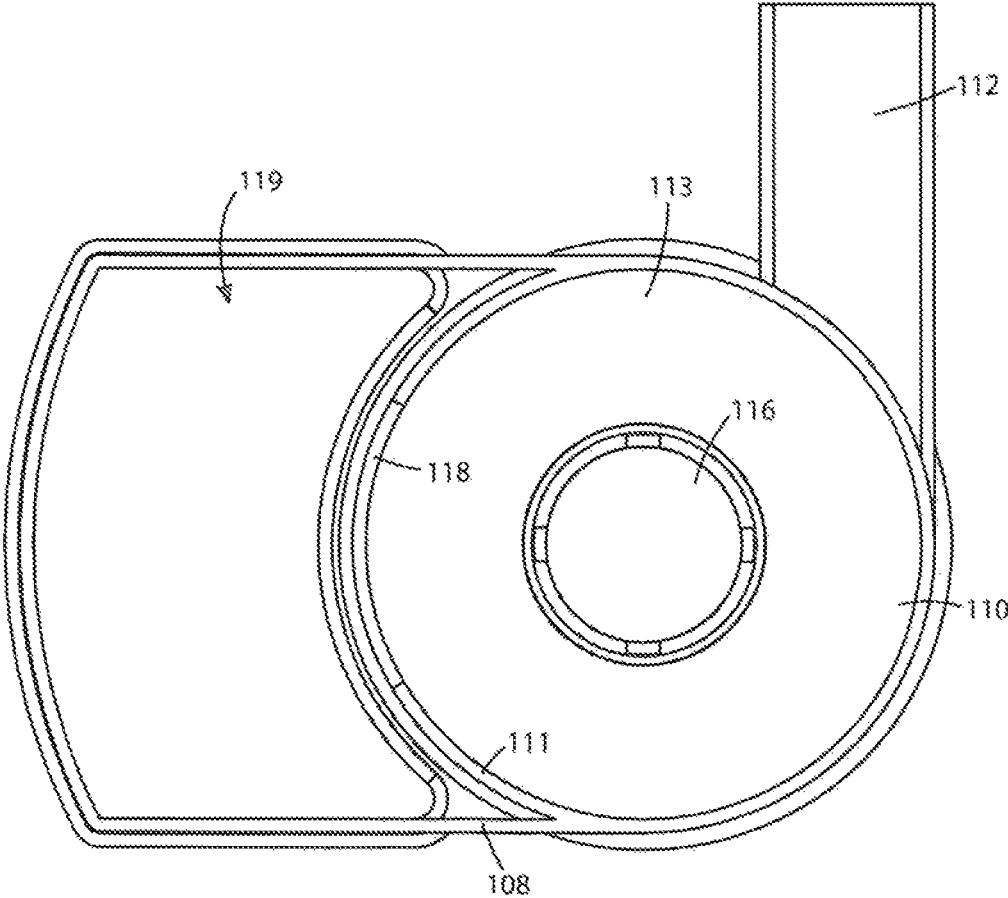

FIG. 30

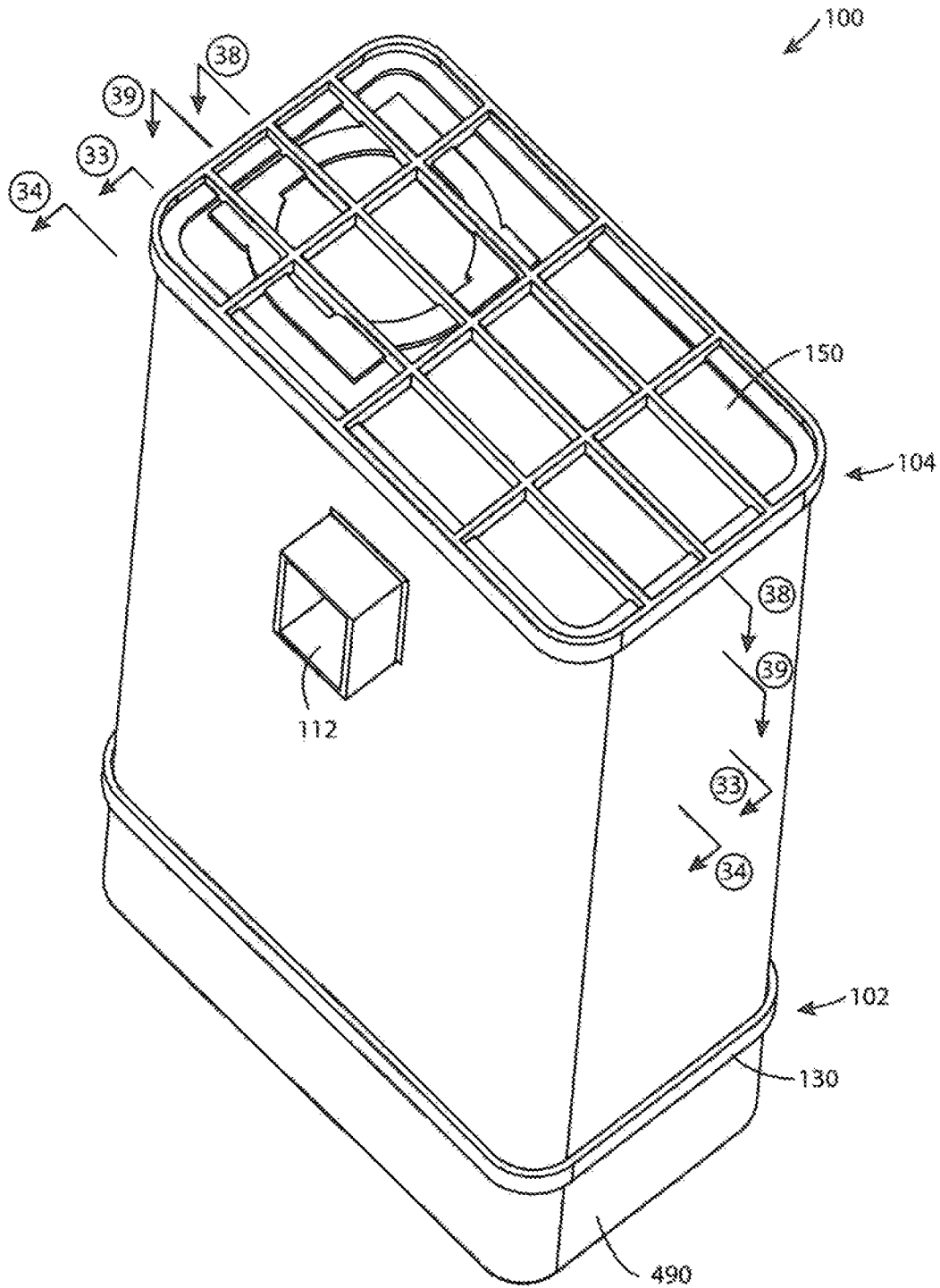

FIG. 31

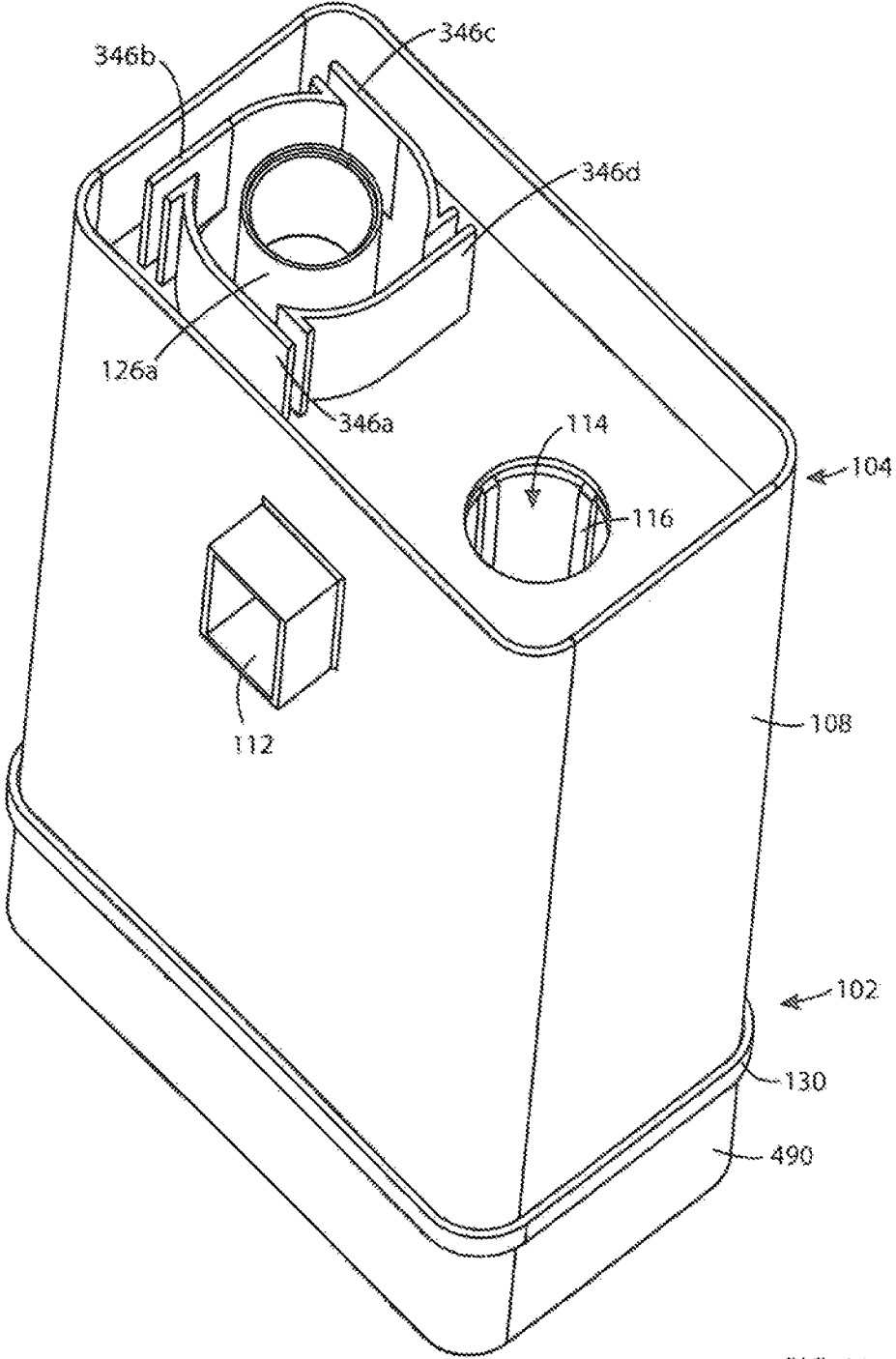

FIG. 32

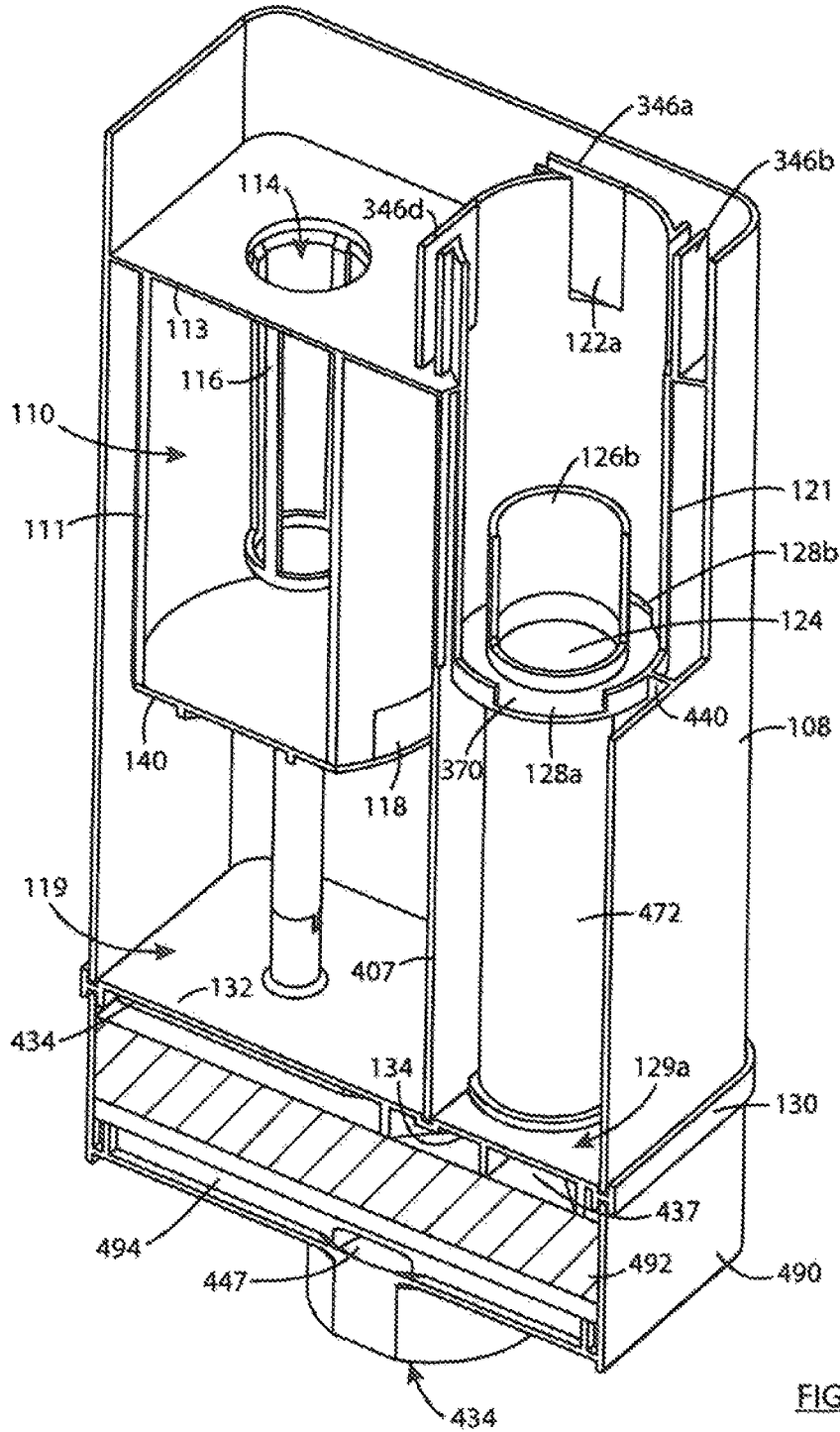

FIG. 33

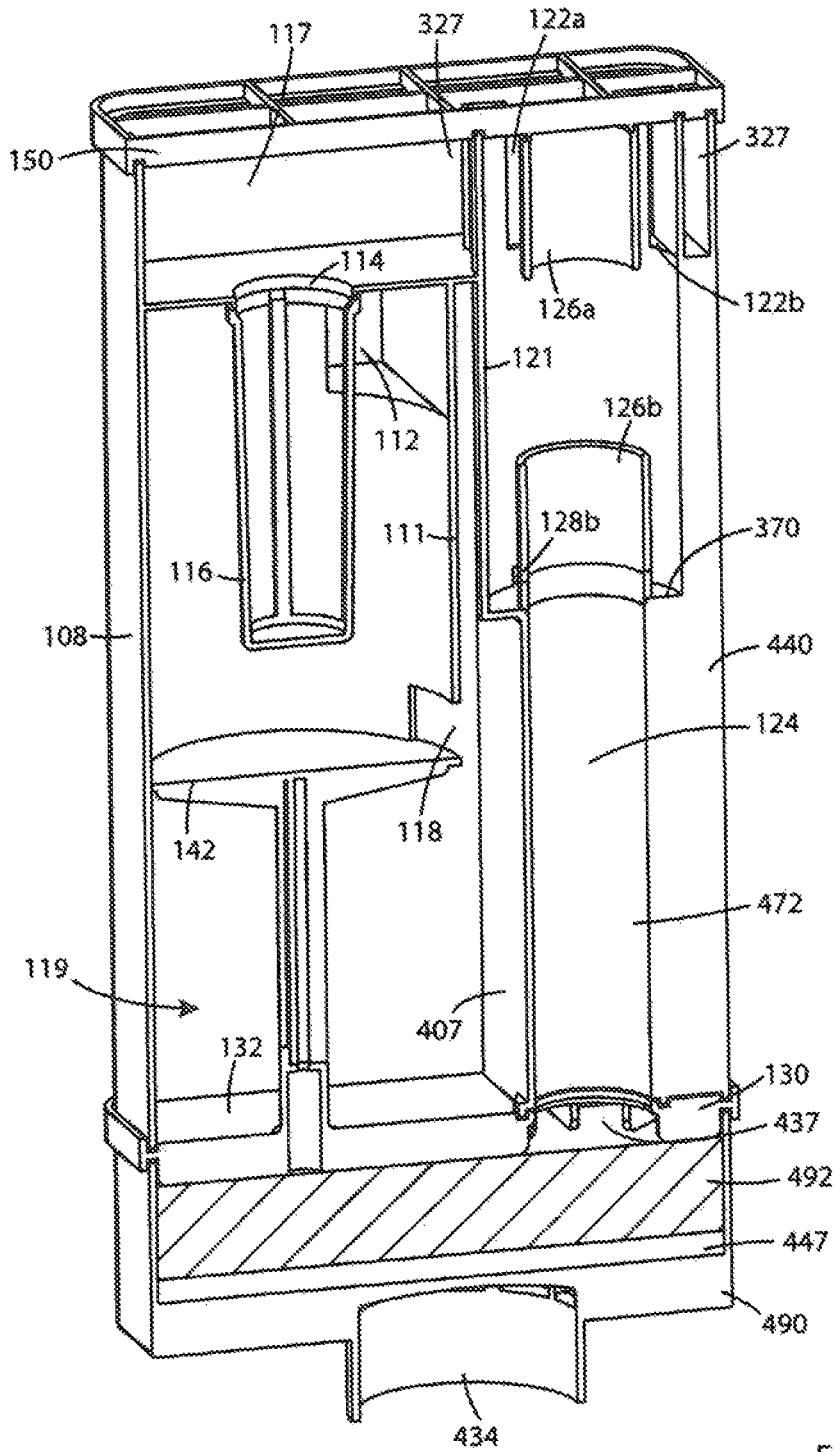

FIG. 34

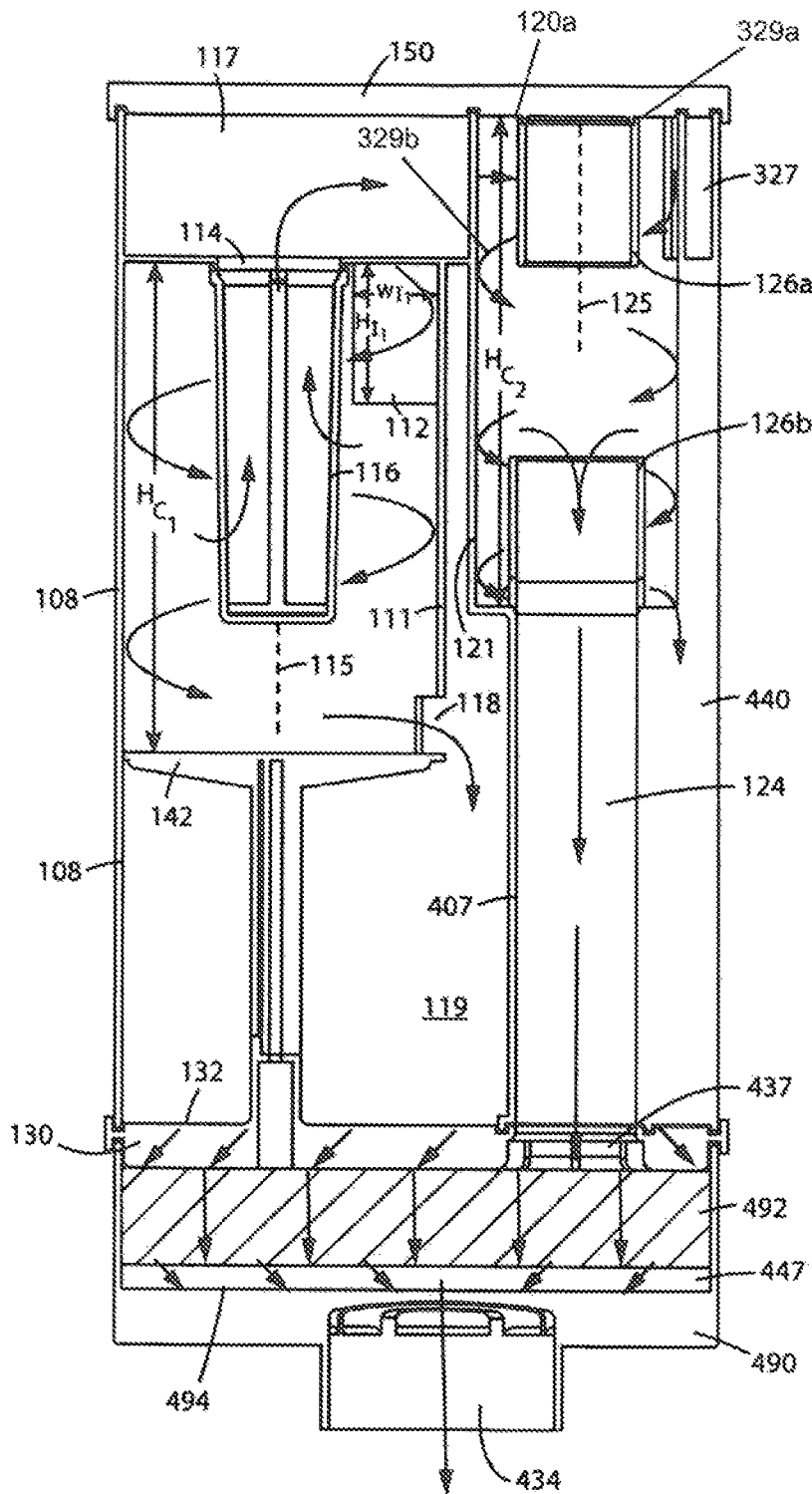

FIG. 35

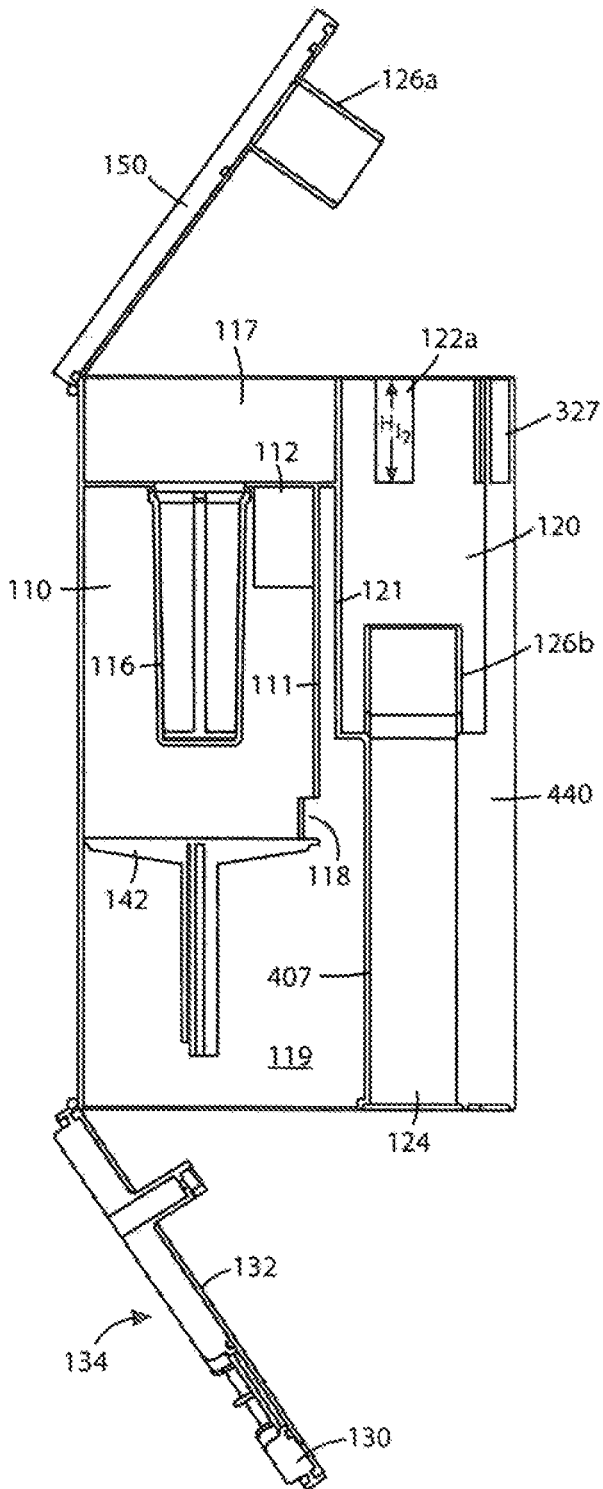

FIG. 36

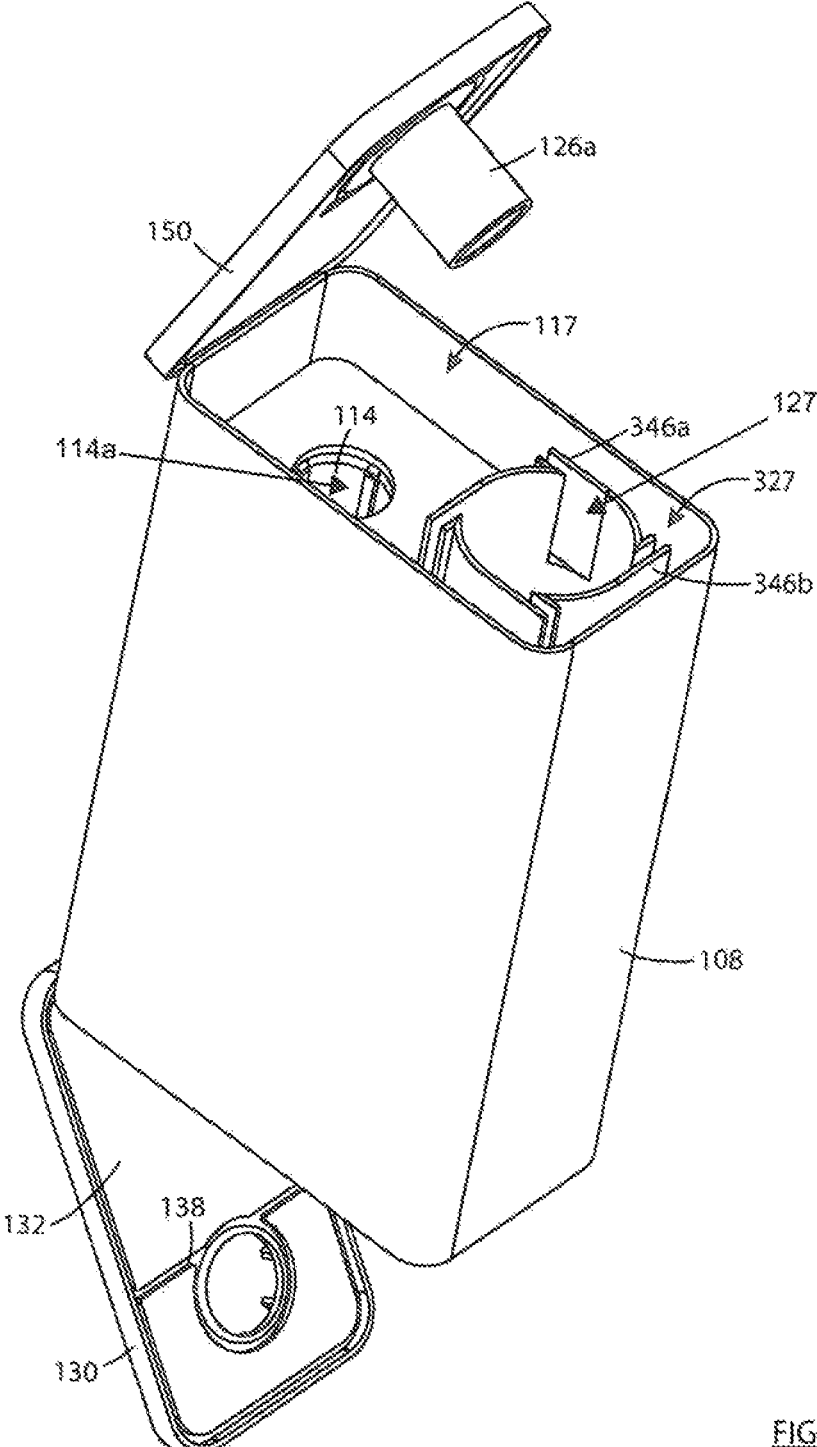

FIG. 37

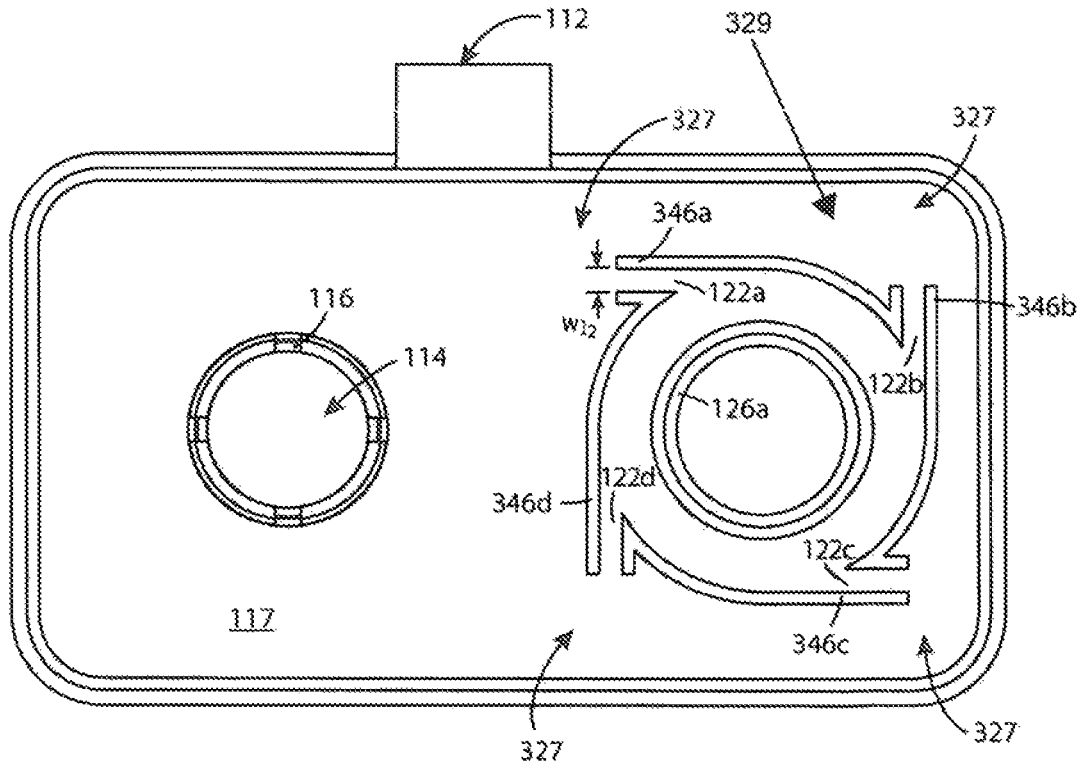

FIG. 38

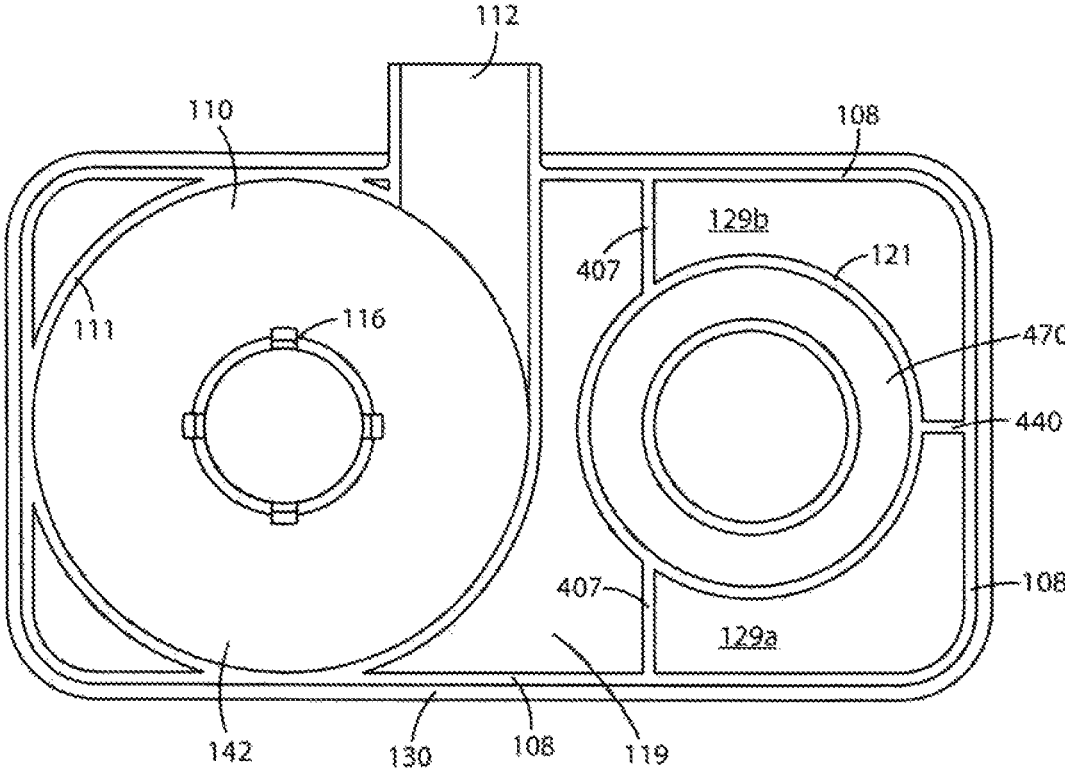

FIG. 39

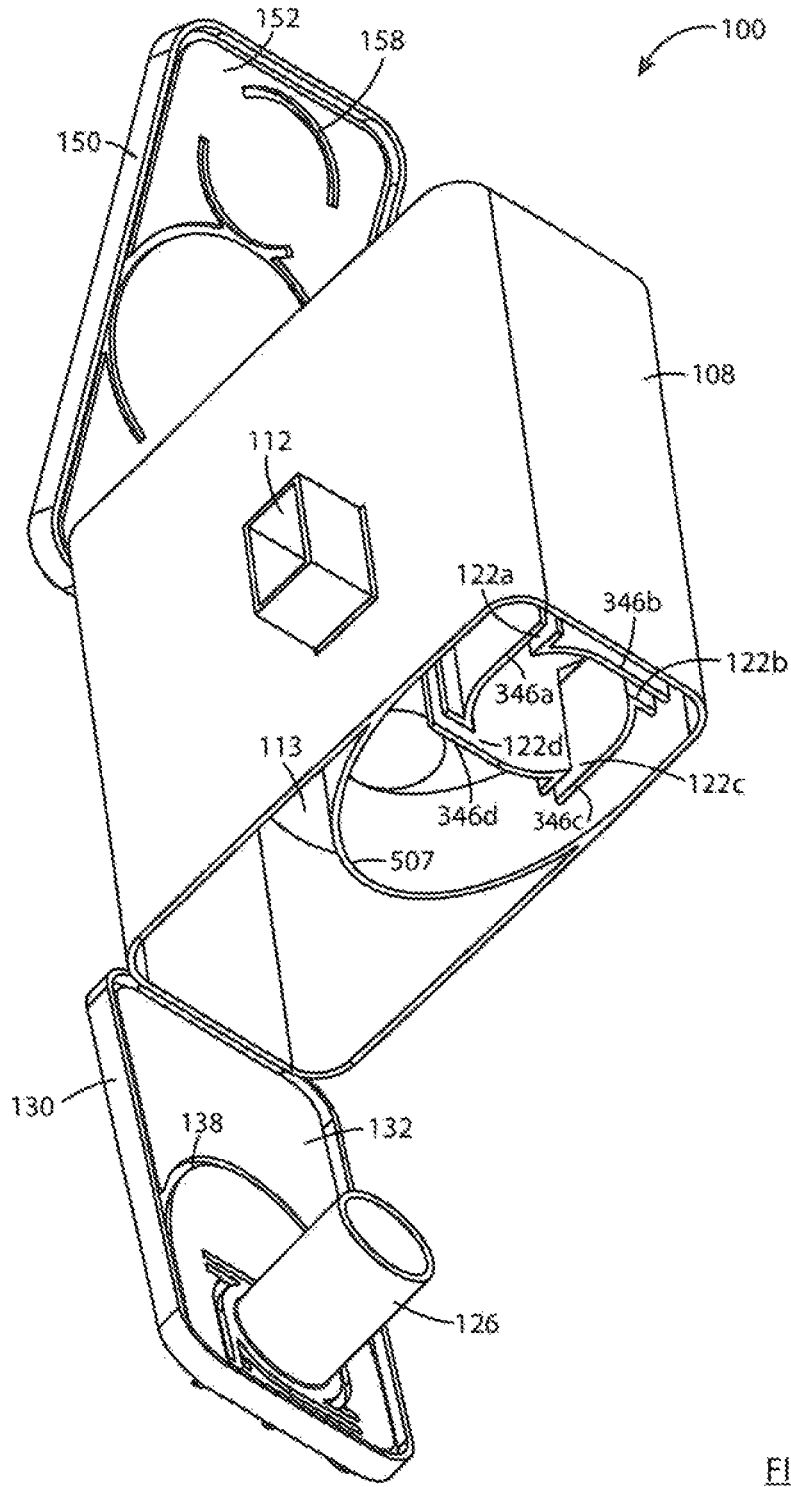

FIG. 40

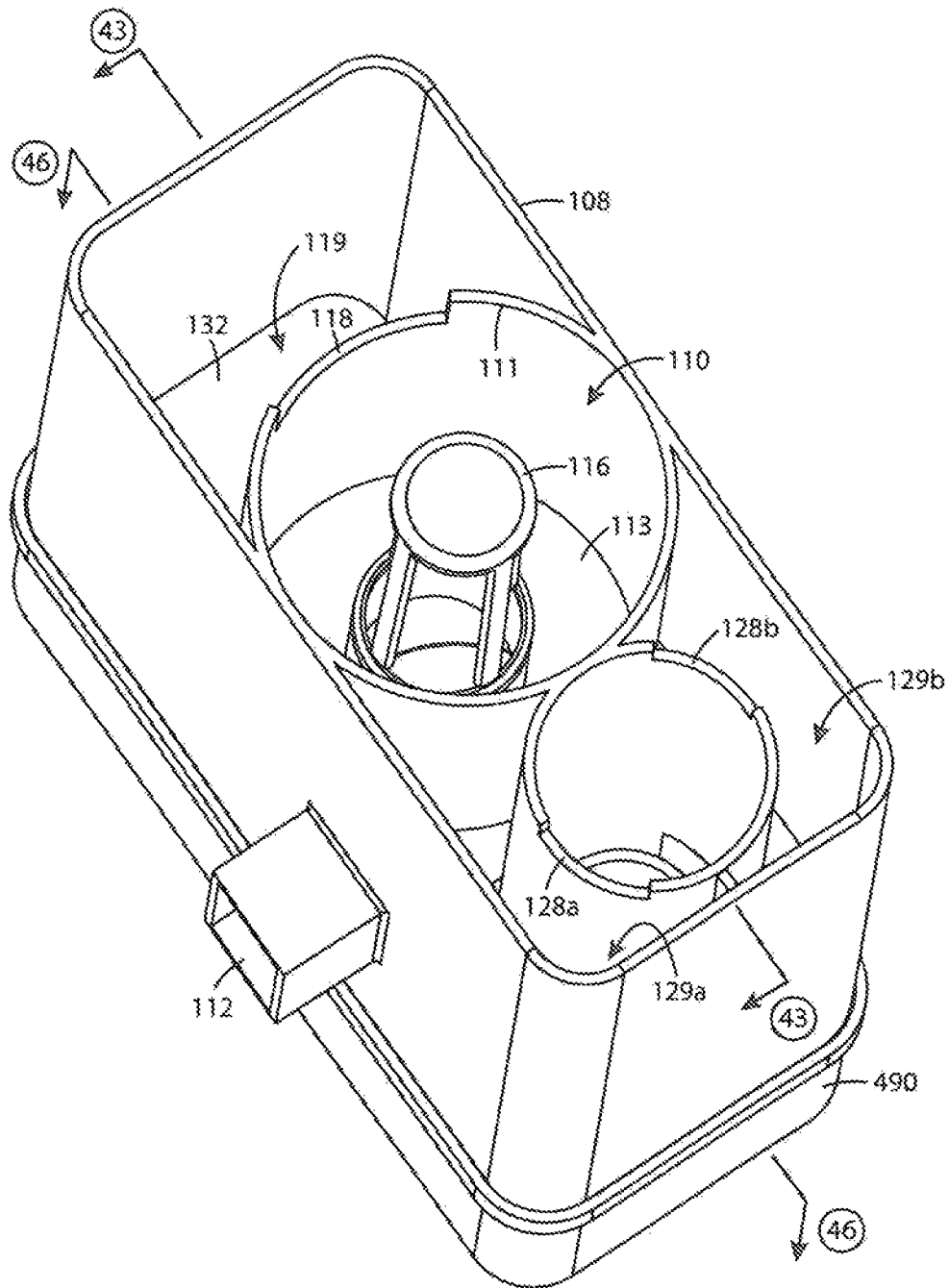

FIG. 41

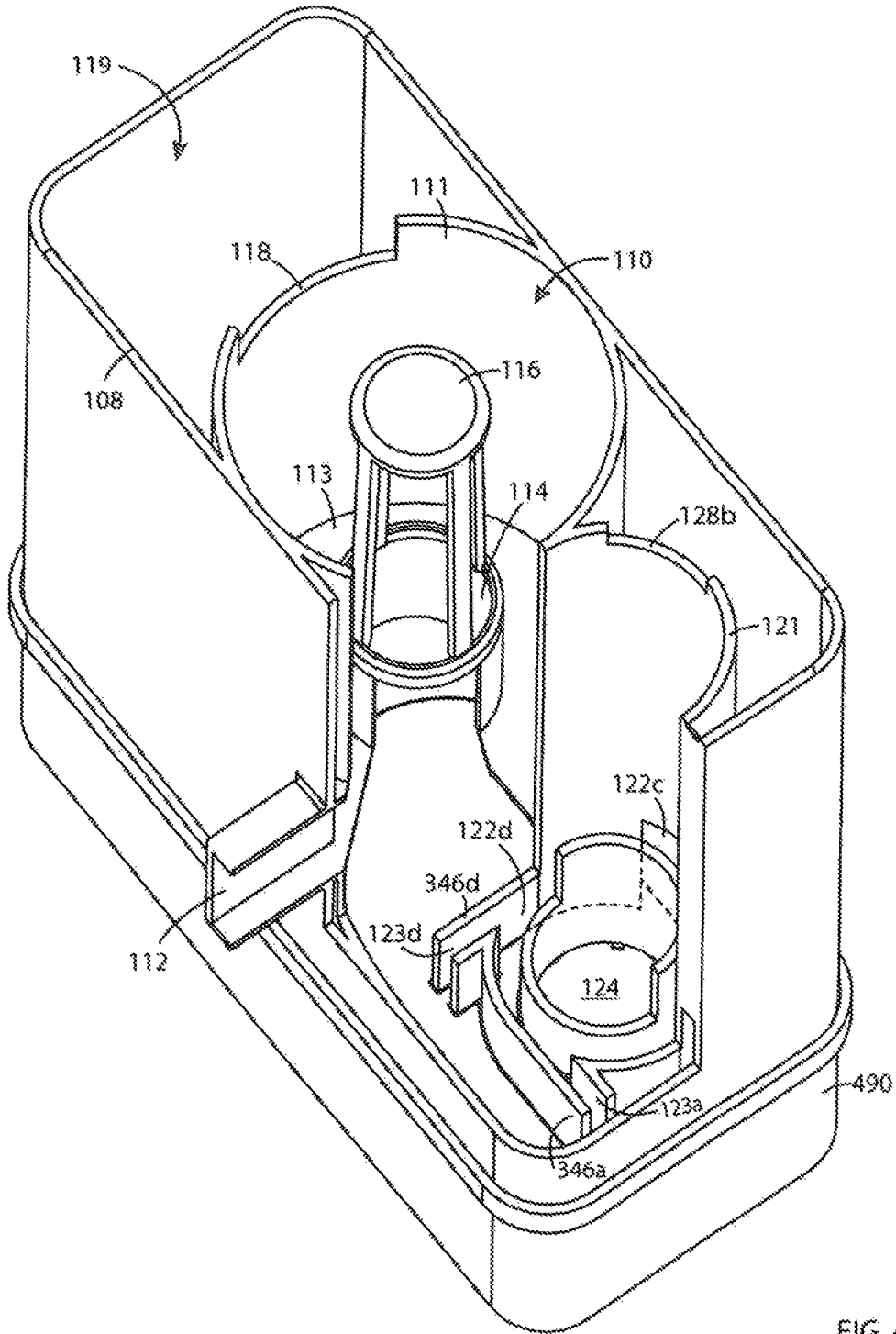

FIG. 42

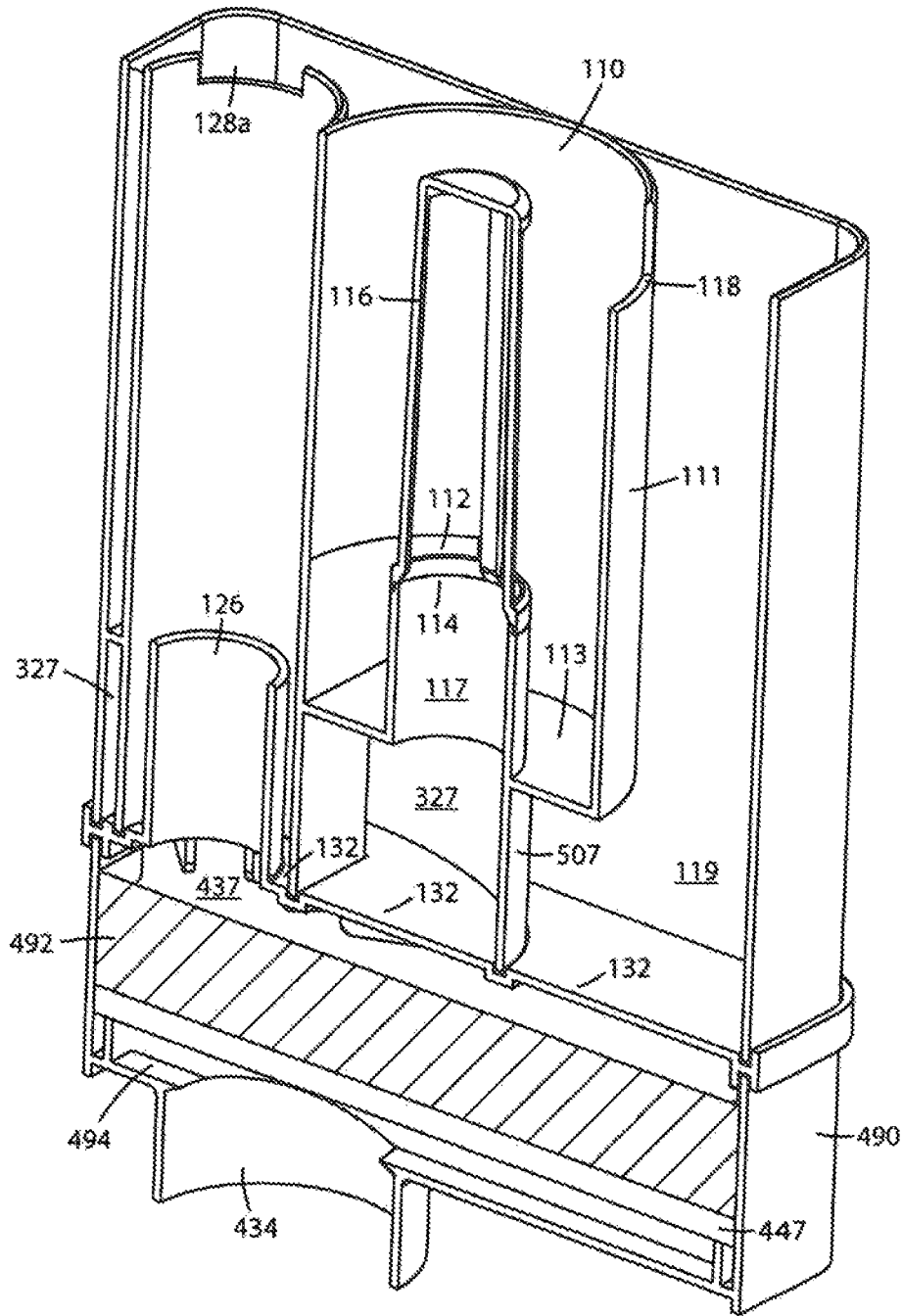

FIG. 43

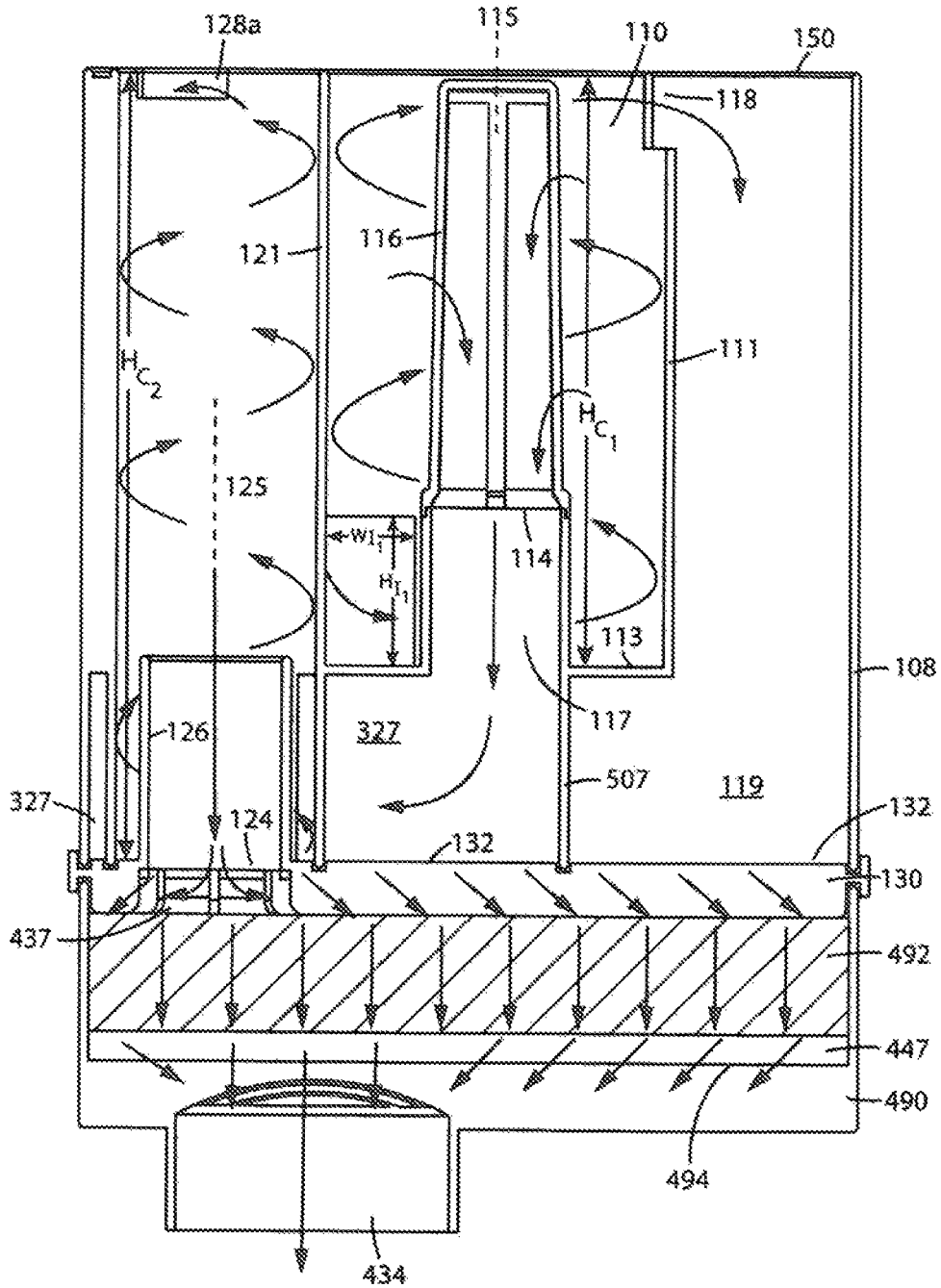

FIG. 44

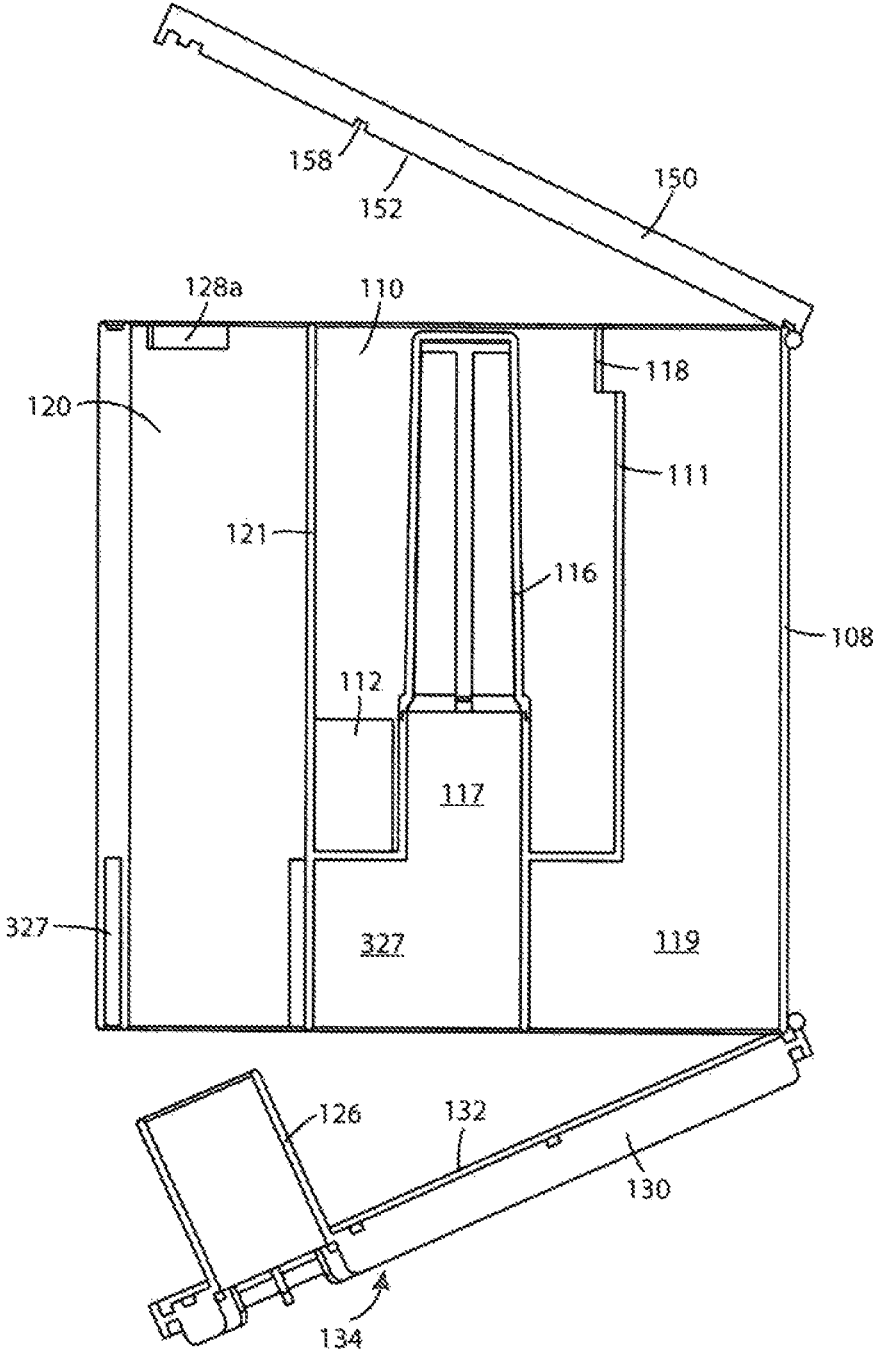

FIG. 45

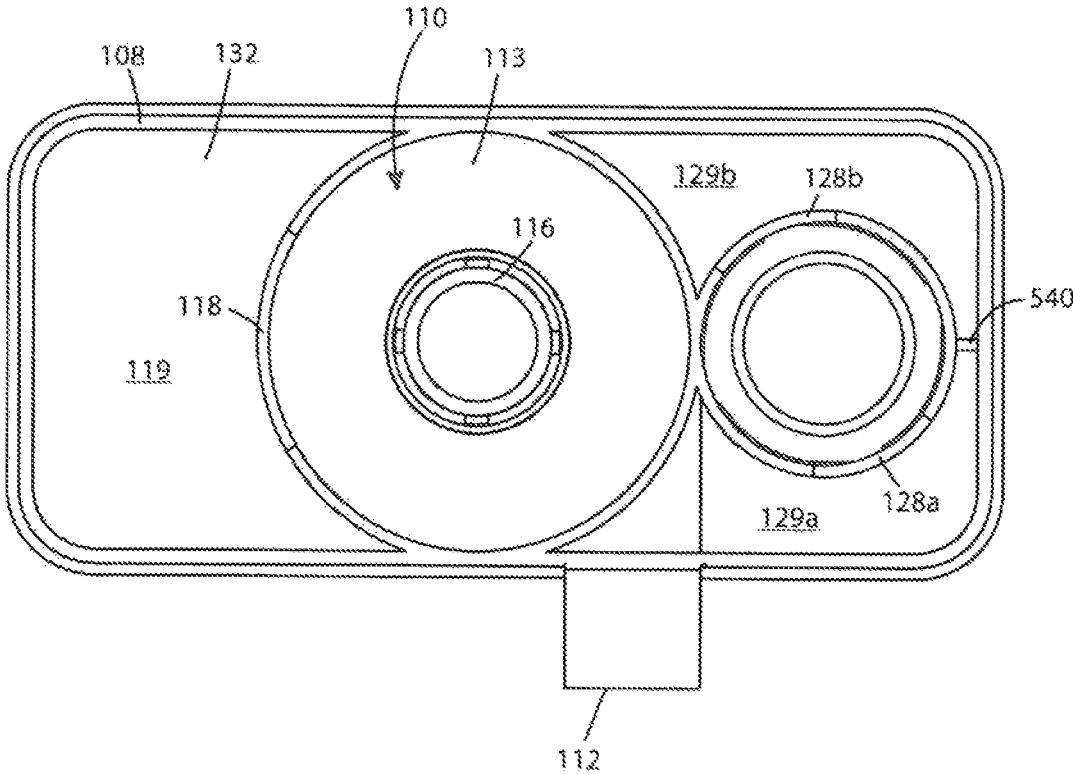

FIG. 46

1

CYCLONE ASSEMBLY FOR SURFACE CLEANING APPARATUS AND A SURFACE CLEANING APPARATUS HAVING SAME

CROSS REFERENCE TO RELATED APPLICATIONS

This application is a continuation of U.S. patent application Ser. No. 15/492,937, filed on Apr. 20, 2017, which is allowed, which itself is a continuation-in-part of U.S. patent application Ser. No. 15/137,814, filed on Apr. 25, 2016, and issued as U.S. Pat. No. 9,936,846 on Apr. 10, 2018, and is also a continuation-in-part of U.S. patent application Ser. No. 15/391,128, filed on Dec. 27, 2016, and issued as U.S. Pat. No. 10,258,210 on Apr. 16, 2019, the disclosure of each of which is incorporated herein by reference in their entirety.

FIELD

This disclosure relates generally to cyclone assemblies for surface cleaning apparatus, and more specifically to cyclone assemblies that have first and second cyclonic cleaning stages.

INTRODUCTION

Various types of surface cleaning apparatus are known, including upright surface cleaning apparatus, canister surface cleaning apparatus, stick surface cleaning apparatus, hand carryable surface cleaning apparatus, and central vacuum systems.

Surface cleaning apparatus that use one or more cyclonic cleaning stages to remove particulate matter (e.g. dust and dirt) from an airstream are known.

A second cyclonic cleaning stage, which may comprise a plurality of cyclones in parallel, may be provided downstream of a first cyclonic cleaning stage and upstream of the suction motor. The second cyclonic cleaning stage is typically provided to remove particulate matter from the airstream exiting the first cyclonic cleaning stage and was not removed from the airstream by the first cyclonic cleaning stage.

Typically, second stage cyclones are effective at removing additional particulate matter from the airstream. However, a pre-motor filter is often provided downstream of the first cyclonic cleaning stage and upstream of the suction motor to protect the suction motor by filtering out particulate matter from the airstream that was not removed from the airstream by either the first or second cyclonic cleaning stage. However, there may be one or more disadvantages associated with providing a pre-motor filter. For example, the pre-motor filter may become clogged with particulate matter, requiring a user to clean and/or replace the filter, a task a user may regard as undesirable.

SUMMARY

The following introduction is provided to introduce the reader to the more detailed discussion to follow. The introduction is not intended to limit or define any claimed or as yet unclaimed invention. One or more inventions may reside in any combination or sub-combination of the elements or process steps disclosed in any part of this document including its claims and figures.

In accordance with one aspect of this disclosure, a cyclone assembly that may be used as an air treatment member to remove particulate matter (e.g. dirt, dust) from an airflow

2

includes a first cyclonic cleaning stage and a second cyclonic cleaning stage located downstream of the first cyclonic cleaning stage wherein the second cyclonic cleaning stage includes a greater number of cyclone chambers than the first cyclonic cleaning stage. The first and second cyclonic stages are configured to provide reduced back pressure caused by air flow through the cyclonic stages. To this end, the cyclone chambers of the second cyclonic cleaning stage may be taller than the cyclone stage(s) of the first cyclonic cleaning stage.

In order to reduce backpressure through such a cyclone assembly, it is preferred that the velocity of the airflow entering the first cyclonic cleaning stage is approximately equal to the velocity of the airflow entering the second cyclonic cleaning stage. While the airflow velocity through the first stage air inlet is preferably approximately equal to the airflow velocity through each of the second stage air inlets, the separation characteristics of the first and second cyclonic cleaning stages may nonetheless be different. For example, if a second stage cyclone chamber has a smaller radius than the first stage cyclone chamber, particles entrained in the airflow in the second stage cyclone will experience a greater centrifugal force than they experienced in the first stage cyclone, which may promote the disentrainment of smaller particles from the airflow in the second cyclonic cleaning stage.

In an effort to achieve relatively equal airflow velocities (e.g., $\pm 25\%$, $\pm 20\%$, $\pm 15\%$, $\pm 10\%$, $\pm 5\%$, the total cross-sectional area of the air inlet(s) of the first cyclonic cleaning stage is preferably approximately equal to the total cross-sectional area of the second stage air inlets (i.e. the sum of the cross-sectional areas of each second stage cyclone chamber air inlet). If the first cyclonic cleaning stage comprises a single cyclone chamber, then the total cross-sectional area of the air inlet of the first cyclonic cleaning stage is preferably approximately equal to the total cross-sectional area of the second stage air inlets.

However, due to boundary layer effects at the perimeter, the effective cross-sectional area of an air inlet may be smaller than the physical dimensions of the inlet. For example, for a rectangular air inlet of height H, width W, and assuming a constant boundary layer thickness L_B , the effective cross sectional area for the inlet may be estimated as:

$$\text{Area}_{\text{Effective}} = (H - (2 \times L_B)) \times (W - (2 \times L_B)) = HW - 2(HL_B + WL_B - 2L_B^2).$$

If the second cyclonic cleaning stage has a larger number of second stage cyclones than the first cyclonic cleaning stage, and therefore a larger number of air inlets, and the sum of the cross sectional areas of the first stage air inlets is equal to the sum of the cross sectional areas of the second stage air inlets, then the sum of the effective cross sectional areas of the first stage air inlets may be less than the sum of the effective cross sectional areas of the second stage air inlets. The reason for this is that the total effective cross-sectional area of the second stage air inlets may be reduced by a greater amount than that of the first stage air inlet(s) as the boundary layer thickness at the perimeter of an inlet is typically not dependent on the area of the inlet. To adjust for this imbalance, the total cross-sectional area of the second stage air inlets, and optionally the cross-sectional area of each second stage air inlet, may be increased by about 5 to 30%, preferably about 10 to 20%, and more preferably by about 15% over what would be required to provide an approximately equal total physical inlet area for the second stage.

Also, it may be assumed that, generally, during each revolution within a cyclone chamber, an air stream moves in the longitudinal direction towards an end of the cyclone chamber by about the height of the cyclone chamber air inlet. For example, in a cyclone chamber that has a longitudinal height that is five times greater than the longitudinal height of its air inlet, the air may be expected to rotate about five times as it travels from the end of the cyclone chamber that has the air inlet to the opposite end of the cyclone chamber.

Accordingly, to provide first and second stage cyclones that have about the same number of turns within their respective cyclone chambers, each cyclone chamber preferably has a similar ratio of the longitudinal height of its air inlet to the longitudinal height of the cyclone chamber. Thus, where the longitudinal height of the air inlet for each second stage cyclone chamber is greater than the longitudinal height of the air inlet for the first stage cyclone chamber, the height of each second stage cyclone chamber is preferably greater than the height of each first stage cyclone chamber.

In accordance with this broad aspect, there is provided a cyclone assembly for a surface cleaning apparatus comprising:

- (a) a first cyclonic cleaning stage comprising at least one first stage cyclone having a first stage cyclone chamber, each first stage cyclone having a first stage longitudinal cyclone axis about which the air rotates in the first stage cyclone chamber, each first stage cyclone chamber having a height extending between a first stage cyclone chamber air inlet and a first stage cyclone dirt outlet; and
- (b) a second cyclonic cleaning stage downstream from the first cyclonic cleaning stage and comprising a plurality of second stage cyclones in parallel, each of the plurality of second stage cyclones has a second stage cyclone chamber having a second stage longitudinal cyclone axis about which the air rotates in the second stage cyclone chamber, each second stage cyclone chamber having a height extending between a second stage cyclone chamber air inlet and a second stage cyclone dirt outlet,

wherein the second cyclonic cleaning stage has a larger number of second stage cyclones than the first cyclonic cleaning stage, and wherein the height of each second stage cyclone chamber is greater than the height of each first stage cyclone chamber.

In some embodiments, the second stage cyclone dirt outlets may be provided in sidewalls of the second stage cyclones.

In some embodiments, the first and second stage longitudinal cyclone axes may be generally parallel.

In some embodiments, the first and second stage cyclones may be inverted.

In some embodiments, some or all of the second stage cyclone chamber air inlets may have a height in a direction of the second stage longitudinal cyclone axis that is greater than a height of each first stage cyclone chamber air inlet in a direction of the first stage longitudinal cyclone axis.

In some embodiments, the height of some or all of the second stage cyclone chamber air inlets may be 1.25 to 2.5 times greater than the height of each first stage cyclone chamber air inlet.

In some embodiments, the height of each second stage cyclone chamber may be greater than the height of each first stage cyclone chamber by at least the height of the first stage cyclone chamber air inlet. Optionally, in some embodiments, each of the second stage cyclone chamber air inlets

may have a height in a direction of the second stage longitudinal cyclone axis that is 1.25 to 2.5 times greater than a height of each first stage cyclone chamber air inlet in a direction of the first stage longitudinal cyclone axis.

In some embodiments, each of the second stage cyclone chamber air inlets may have a width in a direction transverse to the second stage longitudinal cyclone axis according to the following formula

$$W_2 = \frac{W_1}{N} \pm 15\%,$$

wherein W_2 is the width of the second stage cyclone inlets in a direction transverse to the second stage longitudinal cyclone axis; W_1 is the width of the first stage cyclone inlets in a direction transverse to the first stage longitudinal cyclone axis; and, N is the number of second stage cyclones.

Optionally, in some embodiments, some or all of the second stage cyclone chamber air inlets may have a height in a direction of the second stage longitudinal cyclone axis that is greater than a height of the first stage cyclone chamber air inlet in a direction of the first stage longitudinal cyclone axis. Optionally, in some embodiments, the height of some or all the second stage cyclone chamber air inlets may be 1.25 to 2.5 times greater than the height of the first stage cyclone chamber air inlet.

In some embodiments, each of the first and second stage cyclone chamber air inlets may have a cross sectional area and a total of the cross sectional areas of the second stage cyclone chamber air inlets may be greater than a total of the cross sectional area of the first stage cyclone chamber air inlets.

In some embodiments, the total of the cross sectional areas of the second stage cyclone chamber air inlets may be 1.1-2, 1.1-1.5 or 1.1-1.3 times greater than the total of the cross sectional area of the first stage cyclone chamber air inlets.

In some embodiments, each of the first and second stage cyclone chamber air inlets has a cross sectional area and a total of the cross sectional areas of the second stage cyclone chamber air inlets may be greater than a total of the cross sectional area of the first stage cyclone chamber air inlets.

In some embodiments, each of the first and second stage cyclone chambers has a cyclone chamber air outlet and each cyclone chamber air outlet has a cross sectional area and a total of the cross sectional areas of the second stage cyclone chamber air outlets may be greater than a total of the cross sectional area of the first stage cyclone chamber air outlets.

In some embodiments, the total of the cross sectional areas of the second stage cyclone chamber air outlets may be 1.1-2, 1.1-1.5 or 1.1-1.3 times greater than the total of the cross sectional area of the first stage cyclone chamber air outlets.

In some embodiments, the height of each first stage cyclone chamber may be selected such that air rotates 2-4 times in each first stage cyclone chamber and the height of each second stage cyclone chamber may be selected such that air rotates 2-4 times in each second stage cyclone chamber.

In some embodiments, the height of each first and second stage cyclone chamber may be selected such that air rotates about 3 times in each cyclone chamber.

In accordance with another aspect of this disclosure, at least a portion of, and preferably most or substantially all of a second stage dirt collection region may be positioned

5

longitudinally above and overlying the first stage cyclone chamber. Providing the second stage dirt collection region in such a location may facilitate a more compact design of a two stage cyclone assembly.

In accordance with this broad aspect, there is provided a cyclone assembly for a surface cleaning apparatus comprising:

- (a) a first cyclonic cleaning stage comprising at least one first stage inverted cyclone having a first stage cyclone chamber and an upper end;
- (b) a second cyclonic cleaning stage downstream from the first cyclonic cleaning stage and comprising a plurality of inverted second stage cyclones in parallel, each of the plurality of second stage cyclones has a second stage cyclone chamber,

wherein the second cyclonic cleaning stage comprises a second stage dirt collection region and at least a portion of the second stage dirt collection region is positioned longitudinally above the first stage cyclone chamber and overlying the first stage cyclone chamber.

In some embodiments, the at least a portion of the second stage dirt collection region may be positioned on the upper end.

In some embodiments, the second stage dirt collection region may be external to the second stage cyclones.

In some embodiments, the second stage dirt collection region may comprise a plurality of second stage dirt collection chambers.

In some embodiments, each second stage cyclone chamber has a second stage cyclone dirt outlet, each of which may be provided in a sidewall of one of the second stage cyclones.

In some embodiments, the first cyclonic cleaning stage has a first stage dirt collection region that may be external to the at least one first stage inverted cyclone and each first stage cyclone chamber has a first stage cyclone dirt outlet which may be provided in a sidewall of the at least one first stage inverted cyclone.

In some embodiments, the cyclone assembly may further comprise an openable lid which closes an upper end of the second stage cyclones and the second stage dirt collection region wherein when the openable lid is in an open position, the upper end of the second stage cyclones and the second stage dirt collection region may be opened.

In some embodiments, the first cyclonic cleaning stage has a first stage dirt collection region that may be external to the at least one first stage inverted cyclone and the cyclone bin assembly has an upper end comprising the second stage dirt collection region and the upper end may be moveably to an open position in which the at least one first stage inverted cyclone and the first stage dirt collection region are open.

In some embodiments, when the upper end is in the open position the second stage dirt collection region may be closed.

In some embodiments, when the upper end is in the open position the second stage cyclones may also be opened.

In some embodiments, the cyclone assembly further comprises an openable lid which may close an upper end of the second stage dirt collection region wherein when the openable lid is in an open position, the upper end of the second stage dirt collection region may be opened and the openable lid may be openable when the upper end is in the open position.

In some embodiments, when the upper end comprises an upper openable lid which closes an upper end of the second

6

stage dirt collection region and a lower wall, the lower wall may comprise an upper end wall of the at least one first stage inverted cyclone.

In accordance with another aspect of this disclosure, an upstream pre-motor filter chamber or manifold may be positioned facing, e.g., below, the second cyclonic cleaning stage and each of the second stage cyclone air outlets may have an outlet extend to an opening in a wall of the chamber or manifold. An advantage of this design is that fewer conduit walls and/or ducting may be required to direct airflow from the second cyclonic cleaning stage towards the pre-motor filter, which may simplify the design and/or construction of the cyclone assembly and/or surface cleaning apparatus, and/or may reduce backpressure through the surface cleaning apparatus.

In accordance with this broad aspect, there is provided a cyclone assembly for a surface cleaning apparatus comprising:

- (a) a first cyclonic cleaning stage comprising at least one first stage cyclone, which may be an inverted cyclone, having a first stage cyclone chamber and a first stage cyclone air outlet;
- (b) a second cyclonic cleaning stage downstream from the first cyclonic cleaning stage and comprising a plurality of second stage cyclones in parallel, each of the plurality of second stage cyclones may be an inverted cyclone and may each have a second stage cyclone chamber, each of the second stage cyclones having a second stage cyclone air outlet; and
- (c) a pre-motor filter chamber, which may be positioned below the second cyclonic cleaning stage, wherein each of the second stage cyclone air outlets has an outlet end in a wall forming an upstream pre-motor filter chamber.

In some embodiments, the second cyclonic cleaning stage may be removable from the pre-motor filter chamber.

In some embodiments, the second cyclonic cleaning may have an openable bottom wall wherein the second stage cyclones are opened when the openable bottom wall is in an open position.

In some embodiments, the first cyclonic cleaning stage may have a first stage dirt collection region that is external to the at least one first stage inverted cyclone and the first stage dirt collection region may be opened when the openable bottom wall is in an open position.

In some embodiments, the second cyclonic cleaning stage may comprise a second stage dirt collection region and the cyclone assembly may further comprise an openable lid which closes an upper end of the second stage dirt collection region wherein when the openable lid is in an open position, the upper end of the second stage dirt collection region may be opened.

In some embodiments, the cyclone assembly may further comprise a header downstream of the first stage cyclone air outlet and upstream of the second stage cyclones wherein the header is positioned between the first the first stage cyclone air outlet and the pre-motor filter chamber.

In some embodiments, the second cyclonic cleaning may have an openable bottom wall wherein the second stage cyclones and the header are opened when the openable bottom wall is in an open position.

In some embodiments, the first cyclonic cleaning stage may have a first stage dirt collection region that is external to the at least one first stage inverted cyclone and the first stage dirt collection region may be opened when the openable bottom wall is in an open position.

In accordance with another aspect of this disclosure, a release mechanism may be provided which is moveable to

two open positions wherein, in a first open position, a first lock is moved to an unlocked position and in a second open position, a second lock is moved to an unlocked position. An advantage of this design is that the same actuator may be used to unlock an upper end of a cyclone assembly that houses a second stage dirt collection area and to open an upper lid that opens the second stage dirt collection area.

In accordance with another aspect of this disclosure, a cyclone assembly that has two cyclonic stages and may have reduced back pressure during operation is provided. In accordance with this aspect, a cyclone assembly may have first and second cyclonic cleaning stages, and air exiting the first cleaning stage may be directed into an annular flow region that extends around a plurality of air inlets to the second cleaning stage. An advantage of this design is that air may exit the first cyclonic stage through a single air outlet and be directed into a manifold, header, or other conduit that is also in airflow communication with the plurality of second cyclonic stage air inlets, thereby reducing backpressure through the cyclonic assembly.

In accordance with this broad aspect, there is provided a cyclone assembly for a surface cleaning apparatus comprising:

- (a) a first cyclonic cleaning stage comprising a first stage cyclone having a first stage cyclone chamber, a first stage cyclone axis, a first cyclonic stage air inlet, a first cyclonic stage air outlet and a first cyclonic stage air outlet end;
- (b) a second cyclonic cleaning stage downstream from the first cyclonic cleaning stage and comprising a second stage cyclone having a second stage cyclone chamber, a second stage cyclone axis, a plurality of second cyclonic stage cyclone air inlets, and a second cyclonic stage air inlet end; and,
- (c) an annular flow region extending around the second stage air inlet end,

wherein the first cyclonic cleaning stage air outlet communicates directly with the annular flow region.

In some embodiments, the first cyclonic stage air outlet may face the second cyclonic stage cyclone air inlet end.

In some embodiments, the annular flow region may extend axially and have first and second axially spaced apart ends and the first cyclonic stage air outlet may face the first axially spaced apart end.

In some embodiments, a header may be axially located between the first cyclonic stage air outlet and the first axially spaced apart end.

In some embodiments, the header may overlie the first axially spaced apart end.

In some embodiments, the first stage cyclone axis and the second stage cyclone axis may be generally parallel.

In some embodiments, the first stage cyclone axis and the second stage cyclone axis may be generally co-axial.

In some embodiments, the first cyclonic stage air inlet may be at the first cyclonic stage air outlet end.

In some embodiments, the second cyclonic stage air outlet may be axially spaced from the second cyclonic stage air inlet end.

In some embodiments, the first cyclonic cleaning stage may further comprise a first stage dirt chamber exterior to and laterally spaced from the first stage cyclone chamber.

In some embodiments, the first stage cyclone axis and the second stage cyclone axis may be generally parallel and laterally spaced apart.

In some embodiments, the cyclone assembly may further comprise a header between the first cyclonic stage air outlet and the second cyclonic stage cyclone air inlets and the

second cyclonic stage cyclone air inlets may be laterally spaced from and aligned with the header.

In some embodiments, the first cyclonic stage air outlet end may be located at the second cyclonic stage air inlet end.

In some embodiments, the annular flow region may extend axially and have first and second axially spaced apart ends, the first axially spaced apart end may be located at an axial end of the second stage cyclone chamber having the second cyclonic stage air inlets, the second axial spaced apart end may be axially located farther from the axial end of the second stage cyclone than the first axially spaced apart end, and the first cyclonic stage air outlet may be axially located proximate the second axially spaced apart end.

In some embodiments, the first stage cyclone axis and the second stage cyclone axis may be generally parallel and laterally spaced apart, the annular flow region may extend axially and have first and second axially spaced apart ends, the first axially spaced apart end may be located a first distance from an axial end of the second stage cyclone chamber having the second cyclonic stage air inlets, the second axial spaced apart end may be axially located farther from the axial end of the second stage cyclone than the first distance, and the first cyclonic stage air outlet may be axially located proximate the second axially spaced apart end.

In some embodiments, the first cyclonic stage air inlet may be at the first cyclonic stage air outlet end.

In some embodiments, the second cyclonic stage air outlet may be axially spaced from the second cyclonic stage air inlet end.

In some embodiments, the first cyclonic cleaning stage may further comprise a first stage dirt chamber exterior to and axially spaced from the first stage cyclone chamber.

In some embodiments, the first cyclone stage air outlet may face a header and the first stage dirt chamber may be axially spaced from and axially aligned with the header.

A pre-motor filter is typically provided downstream of the cyclonic cleaning stages and upstream of the suction motor, to prevent particulate matter that is not removed from the airstream by the cyclonic cleaning stages from being drawn into the suction motor. Otherwise, this unremoved particulate matter may cause damage to (or otherwise impair) the suction motor. While the use of a pre-motor filter may be effective at protecting the suction motor, there may be one or more disadvantages. For example, the pre-motor filter may become clogged with particulate matter, requiring a user to clean and/or replace the filter, a task a user may regard as undesirable.

In some embodiments disclosed herein, all or substantially all of the dirt entrained in the air exiting the first cyclonic cleaning stage may be removed from the airflow by the second cyclonic cleaning stage. This may, for example, obviate the need to provide a pre-motor filter in the surface cleaning apparatus.

It will be appreciated by a person skilled in the art that an apparatus or method disclosed herein may embody any one or more of the features contained herein and that the features may be used in any particular combination or sub-combination.

These and other aspects and features of various embodiments will be described in greater detail below.

BRIEF DESCRIPTION OF THE DRAWINGS

For a better understanding of the described embodiments and to show more clearly how they may be carried into effect, reference will now be made, by way of example, to the accompanying drawings in which:

FIG. 1 is a perspective view of a surface cleaning apparatus comprising a cyclone assembly in accordance with one embodiment;

FIG. 2 is a perspective view of the cyclone assembly of FIG. 1;

FIG. 3 is a top perspective view of the cyclone assembly of FIG. 2;

FIG. 4 is a top perspective view of the cyclone assembly of FIG. 2, with an upper lid in an open position;

FIG. 5 is a top perspective view of the cyclone assembly of FIG. 2, with an upper end in an open position and the upper lid in a closed position;

FIG. 6 is a perspective view of the cyclone assembly of FIG. 5, with portions of the outer wall removed for clarity;

FIG. 7 is a bottom perspective view of the cyclone assembly of FIG. 2;

FIG. 8 is a bottom perspective view of the cyclone assembly of FIG. 2, with a bottom in an open position;

FIG. 9 is a cross-section view of the surface cleaning apparatus of FIG. 1;

FIG. 10 is an enlarged view of the lower portion of FIG. 9;

FIG. 11 is a section view of the cyclone assembly and suction motor housing of the surface cleaning apparatus of FIG. 8, taken along line 11-11 shown in FIG. 1;

FIG. 12 is a cross-section view of the cyclone assembly of FIG. 2, taken along line 12-12 shown in FIG. 2;

FIG. 13 is a section view of the cyclone assembly of FIG. 2, taken along line 13-13 shown in FIG. 2;

FIG. 14 is a cross-section view of the cyclone assembly of FIG. 2, taken along line 14-14 shown in FIG. 3, with a portion of the lower wall of the first stage cyclone removed to reveal a plurality of second stage cyclone chamber air inlets;

FIG. 15 is a top view of the bottom of the cyclone assembly of FIG. 2;

FIG. 16 is a cross-section view of the surface cleaning apparatus of FIG. 1, taken along line 16-16 shown in FIG. 1, with a release mechanism in a neutral position;

FIG. 17 is a top view of the enlarged portion of FIG. 16;

FIG. 18 is a cross-section view of the surface cleaning apparatus of FIG. 1, taken along line 16-16 shown in FIG. 1, with the release mechanism in a first unlocked position;

FIG. 19 is a cross-section view of the surface cleaning apparatus of FIG. 1, with the release mechanism in a first unlocked position;

FIG. 20 is a cross-section view of the surface cleaning apparatus of FIG. 1, taken along line 20-20 shown in FIG. 1, with the release mechanism in a second unlocked position;

FIG. 21 is a top view of the enlarged portion of FIG. 20, with the release mechanism in a neutral position;

FIG. 22 is a cross-section view of the surface cleaning apparatus of FIG. 1, with the release mechanism in the second unlocked position;

FIG. 23 is a perspective view of a cyclone assembly in accordance with another embodiment;

FIG. 24 is a perspective view of the cyclone assembly of FIG. 23, with portions of the first and second stage cyclones removed to reveal a portion of an annular flow region extending around the second stage air inlet end;

FIG. 25 is perspective view of the cyclone assembly of FIG. 23, with additional portions of the first and second stage cyclones removed;

FIG. 26 is a perspective cross-section view of the cyclone assembly of FIG. 23, taken along line 26-26;

FIG. 27 is a cross-section view of the cyclone assembly of FIG. 23, taken along line 26-26;

FIG. 28 is a perspective cross-section view of the cyclone assembly of FIG. 23, taken along line 29-29;

FIG. 29 is a cross-section view of the cyclone assembly of FIG. 23, taken along line 29-29;

FIG. 30 is a cross-section view of the cyclone assembly of FIG. 23, taken along line 30-30;

FIG. 31 is a perspective view of a cyclone assembly in accordance with another embodiment;

FIG. 32 is a perspective view of the cyclone assembly of FIG. 31, with an end wall removed;

FIG. 33 is a perspective cross-section view of the cyclone assembly of FIG. 31, taken along line 33-33, with an end wall and portions of the second stage cyclone removed;

FIG. 34 is perspective cross-section view of the cyclone assembly of FIG. 31, taken along line 34-34;

FIG. 35 is a cross-section view of the cyclone assembly of FIG. 31, taken along line 34-34;

FIG. 36 is a cross-section view of a variant of the cyclone assembly of FIG. 31, with first and second end walls each in an open position;

FIG. 37 is a perspective view of the cyclone assembly of FIG. 36;

FIG. 38 is a cross-section view of the cyclone assembly of FIG. 31, taken along line 38-38;

FIG. 39 is a cross-section view of the cyclone assembly of FIG. 31, taken along line 39-39;

FIG. 40 is a bottom perspective view of a cyclone assembly in accordance with another embodiment, with first and second end walls each in an open position;

FIG. 41 is a top perspective view of the cyclone assembly of FIG. 41, with an end wall removed;

FIG. 42 is a top perspective view of the cyclone assembly of FIG. 41, with an end wall and portions of the first and second cyclonic cleaning stages removed;

FIG. 43 is perspective cross-section view of the cyclone assembly of FIG. 41, taken along line 43-43;

FIG. 44 is a cross-section view of the cyclone assembly of FIG. 41, taken along line 43-43;

FIG. 45 is a cross-section view of the cyclone assembly of FIG. 40, with first and second end walls each in an open position; and,

FIG. 46 is a cross-section view of the cyclone assembly of FIG. 41, taken along line 46-46.

The drawings included herewith are for illustrating various examples of articles, methods, and apparatuses of the teaching of the present specification and are not intended to limit the scope of what is taught in any way.

DESCRIPTION OF EXAMPLE EMBODIMENTS

Various apparatuses, methods and compositions are described below to provide an example of an embodiment of each claimed invention. No embodiment described below limits any claimed invention and any claimed invention may cover apparatuses and methods that differ from those described below. The claimed inventions are not limited to apparatuses, methods and compositions having all of the features of any one apparatus, method or composition described below or to features common to multiple or all of the apparatuses, methods or compositions described below. It is possible that an apparatus, method or composition described below is not an embodiment of any claimed invention. Any invention disclosed in an apparatus, method or composition described below that is not claimed in this document may be the subject matter of another protective

instrument, for example, a continuing patent application, and the applicant(s), inventor(s) and/or owner(s) do not intend to abandon, disclaim, or dedicate to the public any such invention by its disclosure in this document.

Furthermore, it will be appreciated that for simplicity and clarity of illustration, where considered appropriate, reference numerals may be repeated among the figures to indicate corresponding or analogous elements. In addition, numerous specific details are set forth in order to provide a thorough understanding of the example embodiments described herein. However, it will be understood by those of ordinary skill in the art that the example embodiments described herein may be practiced without these specific details. In other instances, well-known methods, procedures, and components have not been described in detail so as not to obscure the example embodiments described herein. Also, the description is not to be considered as limiting the scope of the example embodiments described herein.

In the examples discussed herein, the surface cleaning apparatus with which the cyclone assembly is used is an upright vacuum cleaner. In alternative embodiments, the surface cleaning apparatus may be another suitable type of surface cleaning apparatus, such as a canister type vacuum cleaner, a hand vacuum cleaner, a stick vac, a wet-dry type vacuum cleaner, a carpet extractor, and the like.

General Description of a Surface Cleaning Apparatus

Referring to FIG. 1, a surface cleaning apparatus is shown generally as 10. The surface cleaning apparatus includes a surface cleaning head 12 and an upper portion 14 that is movably and drivably connected to the surface cleaning head 12. The surface cleaning head 12 may be supported by any suitable support members, such as, for example wheels and/or rollers, to allow the surface cleaning head to be moved across a floor or other surface being cleaned. The support members (e.g., wheels) may be of any suitable configuration, and may be attached to any suitable part of the surface cleaning apparatus, including, for example, the surface cleaning head and/or the upper portion.

The surface cleaning apparatus 10 includes a dirty air inlet 16, a clean air outlet 18 and an air flow path or passage extending therebetween (See FIGS. 9-11). In the illustrated example, the air flow path includes at least one flexible air flow conduit member (such as a hose 15 or other flexible conduit). Alternatively, the air flow path may be formed from rigid members. A cyclone assembly 100 and at least one suction motor are provided in the air flow path. Preferably, the cyclone assembly is provided upstream from a suction unit 20 that contains the suction motor(s), but alternatively may be provided downstream from the suction motor(s). In addition to the cyclone assembly, the surface cleaning apparatus may also include one or more pre-motor filters (preferably positioned in the air flow path between the cyclone assembly and the suction motor) and/or one or more post-motor filters (positioned in the air flow path between the suction motor and the clean air outlet).

General Description of a Cyclone Assembly

FIGS. 2-8 and 12-15 illustrate an embodiment of a cyclone assembly, referred to generally as 100. Cyclone assembly 100 may be used as an air treatment member to remove particulate matter (e.g. dirt, dust) from an air flow. Preferably, the cyclone assembly is removable from the surface cleaning apparatus. Providing a detachable cyclone assembly 100 may allow a user to carry the cyclone assembly 100 to a garbage can for emptying, without needing to carry or move the rest of the surface cleaning apparatus 10. Preferably, the cyclone assembly is removable as a closed

module, which may help prevent dirt and debris from spilling out of the cyclone assembly 100 during transport.

As shown in FIG. 2, the cyclone assembly 100 has a lower end 102, an upper end 104, and an outer sidewall 108. Preferably, an assembly handle 106 is provided at the upper end 104. The assembly handle 106 may facilitate carrying of the cyclone assembly when it is detached from the surface cleaning apparatus 10.

Referring to FIGS. 4-8 and 12-15, cyclone assembly 100 includes a first cyclonic cleaning stage and a second cyclonic cleaning stage located downstream of the first cyclonic cleaning stage. The first cyclonic cleaning stage includes a first stage cyclone chamber 110 that extends along a cyclone axis 115 and includes a generally cylindrical sidewall 111 extending between a lower end wall 113 and an intermediate wall 140 (which is an upper end wall of the cyclone chamber 110). In the illustrated embodiment, the first stage cyclone chamber 110 is arranged in a generally vertical, inverted cyclone orientation. Alternatively, the first stage cyclone chamber can be provided in another orientation, for example as a horizontal or inclined cyclone and may be of any cyclone construction. Alternately, or in addition, the first cyclonic cleaning stage may comprise a plurality of cyclone chambers.

In the illustrated embodiment, the first stage cyclone chamber 110 includes a first stage cyclone air inlet 112 and a first stage cyclone air outlet 114. First stage cyclone chamber 110 also includes at least one dirt outlet 118, through which dirt and debris that is separated from the air flow can exit the cyclone chamber 110. While it is preferred that most or all of the dirt exit the first stage cyclone chamber via the dirt outlet 118, some dirt may settle on the bottom end wall 113 of the cyclone chamber 110 and/or may be entrained in the air exiting the first stage cyclone chamber via the air outlet 114.

In the illustrated example, the first stage cyclone dirt outlet 118 is in the form of a slot bounded by the cyclone side wall 111 and the upper cyclone end wall 140, and is located toward the upper end of the cyclone chamber 110. Alternatively, the dirt outlet may be of any other suitable configuration, and may be provided at another location in the cyclone chamber, including, for example as an annular gap between the sidewall and an end wall of the cyclone chamber or an arrestor plate or other suitable member.

Preferably, the first stage cyclone air inlet 112 is located toward one end of the cyclone chamber 110 (the lower end in the illustrated example) and may be positioned adjacent the corresponding cyclone chamber end wall 113. Alternatively, the cyclone air inlet 112 may be provided at another location within the first stage cyclone chamber 110. Preferably, the air inlet 112 is positioned so that air flowing through the inlet and into the first stage cyclone chamber is travelling generally tangentially relative to, and preferably adjacent, the sidewall 111 of the cyclone chamber 110.

The cross-sectional shape of the air inlet 112 can be any suitable shape. In the illustrated example of FIG. 12, the air inlet has a cross-sectional shape that is generally rectangular (e.g., it has rounded corners and can be referred to as a rounded rectangle) having a height H_T in the longitudinal direction (i.e. parallel to cyclone axis 115) and a width W_T in a transverse direction cyclone axis 115. The cross-sectional area of the air inlet 112 can be referred to as the cross-sectional area or flow area of the first stage cyclone air inlet 112. Alternatively, instead of being a rounded rectangle, the cross-sectional shape of the air inlet may be another shape, including, for example, round, oval, square and rectangular.

13

Referring to FIG. 12, the first stage cyclone chamber 110 has a height H_{C_1} in the longitudinal direction (i.e. parallel to cyclone axis 115). The height of the first stage cyclone chamber 110 is preferably selected such that air entering the cyclone chamber via inlet 112 is expected to rotate approximately 3 to 6 times, 3 to 5 times, 2 to 4 times or three-and-a-half times in the first stage cyclone chamber prior to exiting the cyclone chamber via outlet 114.

In general, it may be assumed that the airflow against the cyclone chamber sidewall as it progresses around the cyclone chamber maintains a degree of cohesion, and that during each revolution within a cyclone chamber, an air stream moves in the longitudinal direction towards an end of the cyclone chamber by a distance approximately equal to the height of the cyclone chamber air inlet. For example, in a cyclone chamber that has a longitudinal height that is five times greater than the longitudinal height of its air inlet, the resulting cyclone may be expected to rotate about five times as it travels from the end of the cyclone chamber that has the air inlet to the opposite end of the cyclone chamber.

Thus, in order to promote the formation of a cyclone that is expected to rotate about three-and-a-half times in the first stage cyclone chamber 110, the height H_{C_1} of the first stage cyclone chamber 110 may be between 3 and 4 times, the height H_{I_1} of the first stage cyclone air inlet 112.

Air can exit the first stage cyclone chamber 110 via the first stage air outlet 114. Preferably, the cyclone air outlet is positioned in one of the cyclone chamber end walls and, in the example illustrated, is positioned in the same end as the air inlet 112 and air inlet 112 may be positioned adjacent or at the end wall 113. In the illustrated embodiment the air outlet 114 is generally circular in cross-sectional shape. Preferably, the cross-sectional or flow area of the first stage cyclone air outlet 114 is generally equal to the flow area of the first stage cyclone air inlet 112. In the illustrated example, the cyclone air outlet 114 comprises a vortex finder 116.

Air exiting the first stage air outlet 114 may be directed into a chamber or manifold 117. From there, the air is directed into the second cyclonic cleaning stage. The second cyclonic cleaning stage includes a plurality of second stage cyclone chambers 120 arranged in parallel. In the illustrated embodiment, six second stage cyclone chambers are shown, referred to as 120a, 120b, 120c, 120d, 120e, and 120f, respectively.

In the illustrated embodiment, each second stage cyclone chamber 120 is arranged in a generally vertical, inverted cyclone orientation. Alternatively, the second stage cyclone chambers can be provided in another orientation, for example as horizontal or inclined cyclones and may be of any cyclone construction.

In the illustrated embodiment, each second stage cyclone chamber extends along a respective cyclone axis 125 (see e.g. FIGS. 5 and 13) and extends between a lower end wall or bottom 130 and an upper end wall 150. In the illustrated embodiment, each second stage cyclone chamber is bounded by a lower sidewall 121 and an upper sidewall extension 141.

In the illustrated embodiment, each second stage cyclone chamber 120 includes a second stage cyclone air inlet 122 and a second stage cyclone air outlet 124. Each second stage cyclone chamber 120 also includes at least one dirt outlet 128, through which dirt and debris that is separated from the air flow can exit the cyclone chamber 120. While it is preferred that most or all of the dirt entrained in the air exiting the first cyclonic cleaning stage exits the second stage cyclone chambers via the dirt outlets 128, some dirt

14

may settle on the bottom end wall 130 of the cyclone chambers 120 and/or may be entrained in the air exiting the second stage cyclone chambers via the air outlets 124.

In some embodiments, all or substantially all of the dirt entrained in the air exiting the first cyclonic cleaning stage may be removed from the airflow by the second cyclonic cleaning stage. This may, for example, obviate the need to provide a pre-motor filter in the surface cleaning apparatus 10.

In the illustrated example, each second stage cyclone dirt outlet 128 is in the form of a slot bounded by the cyclone side wall 121 and the upper cyclone end wall 150, and is located toward the upper end of the cyclone chamber 120. Alternatively, the dirt outlet may be of any other suitable configuration, and may be provided at another location in the cyclone chamber, including, for example as an annular gap between the sidewall and an end wall of the cyclone chamber or an arrestor plate or other suitable member.

Preferably, each second stage cyclone air inlet 122 is located toward one end of the cyclone chamber 120 (the lower end in the illustrated example) and may be positioned adjacent the corresponding cyclone chamber end wall 130. Alternatively, the cyclone air inlet 122 may be provided at another location within the second stage cyclone chamber 120. Preferably, each air inlet 122 is positioned so that air flowing through the inlet and into a second stage cyclone chamber is travelling generally tangentially relative to, and preferably adjacent, the sidewall 121 of the cyclone chamber 120.

The cross-sectional shape of the air inlet 122 can be any suitable shape. In the illustrated example each air inlet has a cross-sectional shape that is generally rectangular (rounded rectangular), having a height H_{I_2} in the longitudinal direction (i.e. parallel to cyclone axis 125) and a width W_{I_2} in a transverse direction. The total cross-sectional area of the second stage air inlets (i.e. the sum of the cross-sectional areas of each inlet 122a-f) can be referred to as the total cross-sectional area or total flow area of the second cyclonic cleaning stage.

Referring to FIG. 12, each second stage cyclone chamber 120 has a height H_{C_2} in the longitudinal direction (i.e. parallel to cyclone axis 125). The height of each second stage cyclone chamber 120 is preferably selected such that air entering the cyclone chambers via inlets 122 is expected to rotate approximately 3 to 6 times, 3 to 5 times, 2 to 4 times or three-and-a-half times in each second stage cyclone chamber prior to exiting the cyclone chamber via outlet 124. For example, the height H_{C_2} of a second stage cyclone chamber 120 may be between 3 and 4 times, the height H_{I_2} of a second stage cyclone air inlet 122.

Air can exit each second stage cyclone chambers 120 via a second stage air outlet 124 provided for each cyclone chamber 120. Preferably, the cyclone air outlets 124a-f are positioned in one of the end walls of each cyclone chamber 120 and, in the example illustrated, are positioned in the same ends as the air inlets 122a-f. In the illustrated embodiment the air outlets 124a-f are generally circular in cross-sectional shape. Preferably, the cross-sectional or flow area of each second stage cyclone air outlet 124 is generally equal to the flow area of the first stage cyclone air inlet 112 for its respective cyclone chamber. In the illustrated example, each cyclone air outlet 124 comprises a vortex finder 126.

Height of Each Second Stage Cyclone Chamber Greater Than the Height of each First Stage Cyclone Chamber

The following is a description of the sizing of a second stage cyclone compared to a first stage cyclone that may be used by itself in any surface cleaning apparatus or in any

combination or sub-combination with any other feature or features disclosed herein including the positioning of the dirt collection region for second stage cyclones, a dual opening latching mechanism and the connection of the second stage cyclone chamber air outlets with an upstream chamber of a pre-motor filter.

In order to reduce backpressure through the cyclone assembly 100, it is preferred that the velocity of the airflow entering the first cyclonic cleaning stage is approximately equal to the velocity of the airflow entering the second cyclonic cleaning stage. That is, the airflow velocity through the first stage cyclone air inlet 112 may be approximately equal to the airflow velocity through each of the second stage cyclone air inlets 122.

In an effort to achieve relatively equal airflow velocities, cyclone assembly 100 may be dimensioned so that the total cross-sectional area of the air inlet for the first cyclonic cleaning stage (i.e. the cross-sectional area of the air inlet 112 in the illustrated example) is approximately equal to the total cross-sectional area of the second stage air inlets (i.e. the sum of the cross-sectional areas of each inlet 122a-f).

However, due to boundary layer effects at the perimeter of the inlet, the effective cross-sectional area of each air inlet 112, 122 may be smaller than the physical dimensions of the inlet. For example, a boundary layer having a thickness of about 0.005 to 0.010 inches may form around the perimeter of each air inlet, reducing the effective cross-sectional or flow area of that inlet. For example, for a rectangular air inlet of height H, width W, and assuming a constant boundary layer L_B , the effective cross sectional area for the inlet may be estimated as:

$$\text{Area}_{\text{effective}} = (H - (2 \times L_B)) \times (W - (2 \times L_B)) = HW - 2(HL_B + WL_B - 2L_B^2)$$

Where the second cyclonic cleaning stage has a larger number of second stage cyclones than the first cyclonic cleaning stage, as in the illustrated example, the total effective cross-sectional area of the second stage air inlets 122 may be reduced by a greater amount than that of the first stage air inlet 112 (as the boundary layer thickness at the perimeter of an inlet is typically not dependent on the area of the inlet). To adjust for this imbalance, the cross-sectional area of each second stage air inlet 122 is preferably increased by about 10 to 30%, and more preferably by about 15% over what would be required to provide an approximately equal physical inlet area to air inlet 112. This may be achieved by varying the width and/or height of the second stage air inlets and preferably varying at least the height of the second stage air inlets. For example, the height of the second stage air inlets may be increased by about 10 to 30%, and more preferably by about 15%.

While the airflow velocity through the first stage cyclone air inlet 112 is preferably approximately equal to the airflow velocity through each of the second stage cyclone air inlets 122, the separation characteristics of the first and second cyclonic cleaning stages may nonetheless be different. For example, since the second stage cyclone chambers 120 each have a smaller radius than the first stage cyclone chamber 110, particles entrained in the airflow in the second stage cyclones will experience a greater centrifugal force than they experienced in the first stage cyclone, which may promote the dis-entrainment of smaller particles from the airflow in the second cyclonic cleaning stage.

In accordance with one feature, the height of each second stage cyclone chamber may be greater than the height of the first stage cyclone chamber. An example of such an arrangement is shown in FIGS. 4-6 and 9-13.

Since the second stage cyclone chambers 120 each have a smaller radius than the radius of the first stage cyclone chamber 110, and since the width of an air inlet to a cyclone chamber is preferably a function of the cyclone chamber diameter, each second stage cyclone air inlet 122 preferably has a narrower width than that of the first stage inlet 112. For example, an air stream entering a cyclone chamber may more or less maintain the same width as it travels through the cyclone chamber. Therefore, the radius of a cyclone chamber may be determined based on the width of the air stream (the width of the air inlet) and the width required for the return air stream travelling to the cyclone chamber air outlet (e.g., the width of a vortex finder). Therefore the radius of a cyclone chamber may be approximately equal to the width of the cyclone chamber air inlet, the width of the wall of the vortex finder and half the diameter of the vortex finder.

In certain preferred embodiments, without taking into account the decreased flow area due to boundary layer effects, the width W_{T_2} for each inlet 122a-f may be within about +/-15% of the width W_{T_1} for inlet 112 divided by the number of second stage cyclone chambers. For example, in the illustrated embodiment, there are six second stage cyclone chambers 120a-f, so the width W_{T_2} for each inlet 122a-f is preferably about

$$\frac{W_{T_1}}{6} \pm 15\%$$

As discussed above, the total cross-sectional area of the second stage air inlets (e.g. the sum of the cross-sectional areas of each inlet 122a-f) may be about 10-30% greater than the total cross-sectional area of the first cyclonic cleaning stage (e.g. the cross-sectional area of the air inlet 112), so that the effective flow area of the second cyclonic cleaning stage is approximately equal to the effective flow area of the first cyclonic cleaning stage, after taking boundary layer effects at the air inlets into account.

In order to determine the height H_{T_2} for each inlet 122, the radius of the second stage cyclones may be first determined based on, e.g., the centrifugal forces to be imposed on an air stream travelling therein. The width of the cyclone chamber air inlet 122 may then be determined to be approximately equal to the radial thickness available in the cyclone chamber in which the air stream will rotate. Finally, the height H_{T_2} for each inlet 122 may be determined based on the cross sectional area required to provide a cross-sectional flow area (taking into account boundary layer losses) that is approximately equal to the cross-sectional flow area of the first stage cyclone air inlet (taking into account boundary layer losses).

In certain other preferred embodiments, the height H_{T_2} of each second stage cyclone chamber air inlet 122 is between about 1.25 to 2.5, 1.25 to 2, 1.25 to 1.75 times greater than the height H_{T_1} of the inlet 112.

As noted above, the height H_{C_2} of a second stage cyclone chamber 120 is preferably between 3 to 6, 3 to 5, 3 to 4 and may be about 3.5 times the height H_{T_2} of a second stage cyclone air inlet 122, and the height H_{C_1} of the first stage cyclone chamber 110 is preferably between 3 to 6, 3 to 5, 3 to 4 and may be about 3.5 times the height H_{T_1} of the first stage cyclone air inlet 112. Thus, since the height H_{T_2} for each inlet 122 is preferably greater than H_{T_1} , the height H_{C_2} of each second stage cyclone chamber 120 is preferably greater than the height H_{C_1} of the first stage cyclone chamber 110.

It will be appreciated that some of the embodiments disclosed herein may not use any of the features of the second stage cyclone chambers disclosed herein and that, in those embodiments, the second stage cyclone chambers may be of various constructions and that in those embodiments any second stage cyclone chamber known in the art may be used.

Dirt Collection Region for Second Stage Cyclones Positioned Above and Overlying the First Stage Cyclone

The following is a description of the positioning of the dirt collection region for second stage cyclones that may be used by itself in any surface cleaning apparatus or in any combination or sub-combination with any other feature or features disclosed herein including the sizing of a second stage cyclone compared to a first stage cyclone, a dual opening latching mechanism and the connection of the second stage cyclone chamber air outlets with an upstream chamber of a pre-motor filter.

In accordance with one feature, at least a portion of, and preferably most or substantially all of a second stage dirt collection region may be positioned longitudinally above and overlying the first stage cyclone chamber. In such an embodiment, this preferred location for the second stage dirt collection region may facilitate a more compact design of the cyclone assembly 100.

Referring to FIG. 11, a first stage dirt collection chamber 119 is in communication with dirt outlet 118 to collect the dirt and debris as it exits first stage cyclone chamber 110. Dirt collection chamber 119 may be of any suitable configuration. Referring to FIGS. 5 and 13, in the illustrated example, the dirt collection chamber 119 is bounded by outer sidewall 108, first stage cyclone side wall 111, lower end wall 130, and intermediate wall 140.

As shown in FIGS. 9 and 10, in use air enters the first stage cyclone chamber 110 via air inlet 112 and exits the chamber 110 via air outlet 114, while separated dirt and debris exits the cyclone chamber 110 via dirt outlet 118, where it collects in the first stage dirt collection chamber 119.

To help facilitate emptying the dirt collection chamber 119, at least one of or both of the end walls 130, 140 may be openable. Preferably, end wall 130 is moveable between a closed position (FIG. 13 and FIG. 7) and an open position (FIG. 8). When the end wall 130 is in the open position, the first stage dirt collection chamber 119 and the manifold 117 may be emptied concurrently. In addition, the second cyclone chambers are also opened so that the second cyclone chambers may also be concurrently openable. Optionally, it will be appreciated that the second stage cyclone chambers need not be opened, e.g., if the lower ends of the second stage cyclone chambers are not moveable with end wall 130. Accordingly, the lower end walls of the dirt collection chamber 119 and/or the cyclone chamber 110 and/or the second stage cyclone chambers 120 need not be integral with each other, and the dirt collection chamber 119 and/or the cyclone chamber 110 and/or the second stage cyclone chambers 120 may be openable independently or in a sub-combination, e.g., the dirt collection chamber 119 and the cyclone chamber 110 may be openable independently of the second stage cyclone chambers 120 or the dirt collection chamber 119 and the second stage cyclone chambers 120 may be openable independently of the cyclone chamber 110.

End wall 130 is preferably configured so that when it is in the closed position, the upper surface 132 cooperatively engages a lower surface of one or more of the sidewalls 108, 111, and 121a-f. For example, as shown in FIGS. 8 and 15, the upper surface 132 may have one or more channels or

grooves 138 configured to receive the ends of sidewalls 108, 111, and 121a-f when the end wall 130 is in the closed position. Optionally, one or more sealing or gasketing elements may be provided between groove(s) 138 and the sidewall ends. Alternatively, the upper surface 132 may be relatively planar, and configured to abut the sidewalls 108, 111, and 121a-f, with or without gasketing elements.

Referring to FIG. 5, in the illustrated example, intermediate wall 140 acts as an upper end wall for both dirt collection chamber 119 and first stage cyclone chamber 110. Wall 140 is moveable between a closed position (FIG. 13) and an open position (FIG. 5). When the intermediate wall 140 is in the open position, the first stage cyclone chamber 110, the first stage dirt collection chamber 119, and the second stage cyclone chambers 120a-f can be emptied concurrently. Alternatively, the upper end walls of the dirt collection chamber 119 and/or the cyclone chamber 110 and/or the second stage cyclone chambers 120 need not be integral with each other, and the dirt collection chamber 119 and/or the cyclone chamber 110 and/or the second stage cyclone chambers 120 may be openable independently or in a sub-combination, e.g., the dirt collection chamber 119 and the cyclone chamber 110 may be openable independently of the second stage cyclone chambers 120 or the dirt collection chamber 119 and the second stage cyclone chambers 120 may be openable independently of the cyclone chamber 110.

Wall 140 is preferably configured so that when it is in the closed position, the lower surface 144 cooperatively engages an upper surface of one or more of the sidewalls 108, 111, and 121a-f. For example, as shown in FIGS. 5 and 6, the lower surface 144 may have one or more channels or grooves 148 configured to receive the ends of sidewalls 108, 111, and 121a-f when the wall 140 is in the closed position. Optionally, one or more sealing or gasketing elements may be provided between groove(s) 148 and the sidewall ends. Alternatively, the lower surface 144 may be relatively planar, and configured to abut the sidewalls 108, 111, and 121a-f, with or without gasketing elements.

As exemplified in FIGS. 4 and 11, a second stage dirt collection chamber 129 may be associated with each second stage cyclone chamber 120. As illustrated, each second stage dirt collection chamber 129a-f is in communication with a dirt outlet 128a-f of its respective cyclone chamber 120a-f to collect the dirt and debris as it exits that second stage cyclone chamber. Dirt collection chambers 129a-f may be of any suitable configuration. Referring to FIGS. 4 and 13, in the illustrated example, each dirt collection chamber 129 is bounded an upper sidewall extension 141, intermediate wall 140, upper end wall 150, and one or more interior divider walls 145.

Alternately, two or more second stage cyclone chambers 120 may be associated with a single second stage dirt collection chamber. Accordingly, for example, a single second stage dirt collection chamber may be provided. Collectively, the second stage dirt collection chamber(s) may be referred to generally as a second stage dirt collection region. Accordingly, while in the illustrated example each second stage cyclone chamber 120a-f has its own associated second stage dirt collection chamber 129a-f, this need not be the case. For example, fewer or no interior divider walls 145 may be provided, resulting in two or more second stage dirt outlets being in communication with a shared second stage dirt collection chamber.

As shown in FIGS. 9 and 10, in use air enters each second stage cyclone chamber 120a-f via an air inlet 122a-f and exits each chamber 120a-f via an air outlet 124a-f, while

separated dirt and debris exits each cyclone chamber **120a-f** via a dirt outlet **128a-f**, where it collects in the second stage dirt collection region.

To help facilitate emptying the dirt collection chambers **129a-f**, end wall **150** may be openable. Preferably, end wall **150** is moveable between a closed position (FIG. **13** and FIG. **5**) and an open position (FIG. **4**). When the end wall **150** is in the open position, the second stage dirt collection chambers **129a-f** can be emptied concurrently.

Notably, in the illustrated configuration, when the end wall **150** is in a closed position and the intermediate wall **140** is in the open position, as shown in FIG. **5**, the first stage cyclone chamber **110**, the first stage dirt collection chamber **119**, and the second stage cyclone chambers **120a-f** may be emptied concurrently, while the second stage dirt collection chambers **129a-f** remain closed.

It will be appreciated that the second stage dirt collection region may be opened regardless of the position of the upper end **104** (i.e., whether intermediate wall **140** is open or closed).

It will be appreciated that some of the embodiments disclosed herein may not use any of the features of the dirt collection chambers disclosed herein and that, in those embodiments, the dirt collection chambers may be of various constructions and that in those embodiments any dirt collection chamber known in the art may be used.

Cyclone Assembly with Coaxial Cyclonic Cleaning Stages

The following is a description of a cyclone assembly that may be used by itself in any surface cleaning apparatus or in any combination or sub-combination with any other feature or features disclosed herein including the sizing of a second stage cyclone compared to a first stage cyclone, and the connection of the second stage cyclone chamber air outlets with an upstream chamber of a pre-motor filter.

FIGS. **23-30** exemplify another embodiment of a cyclone assembly, referred to generally as **100**. Elements having similar structure and/or performing similar function as those in the example cyclone assembly illustrated in FIGS. **2-8** and **12-15** are numbered similarly, and will not be discussed further.

As exemplified in FIGS. **24** to **29**, air exiting the first stage air outlet **114** may be directed into an annular flow region that extends around an air inlet end of the second cyclonic cleaning stage. In the illustrated example, the annular flow region includes a central chamber or manifold **117** bounded by an upper surface **344** of an intermediate wall member **340**, the lower end wall **113** of the first stage cyclone chamber **110**, and an upper portion of annular sidewall **381**. Manifold **117** directs airflow outwardly and downwardly into an annular inlet region **327** bounded by a lower portion of annular sidewall **381**, cyclone side wall **121**, and an inlet region end wall **380**. From there, the air is directed into the second cyclonic cleaning stage through, e.g., two or more air flow passages or air inlets, which may be any air inlet known in the art or may be an inlet as disclosed herein. In the illustrated embodiment, the second cyclonic cleaning stage includes a single second stage cyclone chamber **120** arranged co-axially with the first stage cyclone chamber **110**.

In the illustrated embodiment, the second stage cyclone chamber **120** extends between a first end wall **340** and a second end wall **370**, and is bounded by a sidewall **121**. As shown, a lower surface **342** of intermediate wall member **340** (i.e. the wall member that also defines manifold **117**) is an end wall of the second stage cyclone chamber **120**, although this need not be the case.

In the illustrated embodiment, the second stage cyclone chamber **120** includes a plurality of airflow inlets (e.g., the second stage cyclone air inlets may be as disclosed herein, e.g., they may comprise passages **123** bounded in part by wall members **346**, each extending from annular inlet region **327** to a respective second stage cyclone air inlet **122**), and a second stage cyclone air outlet **124**. In the illustrated embodiment, the air inlets of the second stage cyclone chamber (i.e. air inlets **122a-122d**) are positioned radially equidistantly at the inlet end of the second cyclonic cleaning stage (see e.g. FIG. **29**). Alternatively, the air inlets of the second cyclonic stage may be arranged in any suitable manner. Also, while four second stage air inlets are illustrated, it will be appreciated that, alternatively, two or three or five or more second stage air inlets may be provided.

Also, in the illustrated embodiment, the air inlets of the second stage cyclone chamber and the annular inlet region **327** are axially spaced from first stage cyclone air outlet **114** and from header **117**. Axially spacing the second stage cyclone air inlets and the annular inlet region **327** from an air outlet of the first cyclonic cleaning stage may have one or more advantages. For example, it may facilitate airflow through the first and second cyclonic cleaning stages with reduced bends in an air flow conduit thereby reducing the back pressure through the cyclone assembly.

Also, in the illustrated embodiment, the header **117** overlies the upstream end of annular inlet region **327**. Having the header **117** overlie the annular inlet region **327** may have one or more advantages. For example, it may facilitate airflow through the first and second cyclonic cleaning stages and/or it may facilitate a more compact design of the cyclone assembly.

As exemplified in FIGS. **26** and **27**, a second stage dirt collection chamber **129** may be bounded by an outer sidewall **361**, an inner sidewall **363**, and first and second end walls **360**, **362**. Referring to FIG. **26**, in the illustrated example, end wall **360** acts as an end wall for the second stage dirt collection chamber **129**. Wall **360** is preferably moveable between a closed position (e.g. FIG. **26**) and an open position (not shown) in which the second stage dirt collection chamber **129** may be emptied.

Cyclone Assembly with Non-Inverted Cyclonic Cleaning Stages

The following is a description of a cyclone assembly that may be used by itself in any surface cleaning apparatus or in any combination or sub-combination with any other feature or features disclosed herein including the sizing of a second stage cyclone compared to a first stage cyclone, and the connection of the second stage cyclone chamber air outlets with an upstream chamber of a pre-motor filter.

FIGS. **31-39** exemplify another embodiment of a cyclone assembly, referred to generally as **100**. Elements having similar structure and/or performing similar function as those in the example cyclone assembly illustrated in FIGS. **23** to **30** are numbered similarly, and will not be discussed further.

As exemplified in FIGS. **33** to **38**, the air inlets of the second stage cyclone may be any air inlet known in the art or may be an inlet as disclosed herein and may use a manifold and annular flow chamber as discussed previously. As exemplified, air exiting the first stage air outlet **114** may be directed into a flow region that extends around an air inlet end of the second cyclonic cleaning stage. Where, as in the illustrated example, the air inlet end of the second cyclonic cleaning stage comprises a generally annular array of air inlets, the flow region may be characterized as an annular flow region. In the illustrated example, the annular flow region includes a chamber or manifold **117** that directs

airflow laterally into an annular inlet region **327**. From there, the air is directed into the second cyclonic cleaning stage through two or more air flow passages or air inlets. In the illustrated embodiment, the second cyclonic cleaning stage includes a single second stage cyclone chamber **120** arranged parallel to the first stage cyclone chamber **110** (i.e. cyclone axes **115** and **125** are generally parallel) but unlike the embodiment of FIG. **26**, they are laterally spaced apart and are not coaxial.

In the illustrated embodiment, the second stage cyclone chamber **120** includes a plurality of airflow passages **123** bounded in part by wall members **346**, each extending from annular inlet region **327** to a respective second stage cyclone air inlet **122**, and a second stage cyclone air outlet **124**. In the illustrated embodiment, the air inlets of the second stage cyclone chamber (i.e. air inlets **122a-122d**) are positioned radially equidistantly at the inlet end of the second cyclonic cleaning stage (see e.g. FIG. **38**). Alternatively, the air inlets of the second cyclonic stage may be arranged in any suitable manner. Also, while four second stage air inlets are illustrated, it will be appreciated that, alternatively, two or three or five or more second stage air inlets may be provided.

Also, in the illustrated example, an optional vortex finder **126a** is provided at the inlet end of the cyclone chamber **120**, in addition to vortex finder **126b** provided at the outlet end of the cyclone chamber **120**. Such a vortex finder **126a** may not be provided in alternative embodiments.

Also, in the illustrated embodiment, the first cyclonic stage air outlet end **114a** (the first stage air outlet **114**) is located at the second cyclonic stage air inlet end **127**. Accordingly, air exits the first stage air outlet **114** into manifold **117** from which it is directed laterally to the annular inlet region **327** around the air inlet end of the second stage cyclone. Accordingly, an enclosed conduit having 90 degree bends is not required to transfer the air between the first and second stage cyclones. Accordingly, the back pressure through the cyclone assembly may be reduced.

Also, in the illustrated embodiment, the annular flow region **329** (which includes the annular inlet region **327** and manifold **117**) extends axially and has first and second axially spaced apart ends. The first axially spaced apart end **329a** of the annular flow region is located at the axial end **120a** of the second stage cyclone chamber having the second cyclonic stage air inlets (e.g., the upper end of the second stage cyclone chamber of FIG. **35**, which abuts lid **150**). The second axially spaced apart end **329b** of annular flow region is axially located farther from the axial end **120a** of the second stage cyclone than the first axially spaced apart end (e.g., the upper surface of end wall **113** of the first stage cyclone chamber **110**). Further, the first cyclonic stage air outlet **114** is axially located proximate the second axially spaced apart end. Accordingly, the height of the inlets **122** and passages **123** may be about the same as the axial height of the manifold **117**, which may reduce back pressure through the cyclone assembly.

One or both of the cyclonic stages, and as exemplified in FIGS. **33** and **39**, the second stage cyclone may have two or more dirt outlets **128** and a second stage dirt collection chamber **129** may be associated with each dirt outlet **128** of the second stage cyclone chamber **120**. In the illustrated example, each dirt collection chamber **129a**, **129b** is bounded by outer sidewall **108**, inner sidewalls **407**, **472**, and **440**, and end wall **130**. Wall **130** is preferably moveable between a closed position (e.g. FIG. **34**) and an open position (e.g. FIG. **36**) in which the second stage dirt collection chambers **129a**, **129b** may be emptied concur-

rently with the first stage dirt collection chamber **119**. Alternatively, two or more second stage dirt outlets **128** may be associated with a single second stage dirt collection chamber. Accordingly, for example, a single second stage dirt collection chamber may be provided. Collectively, the second stage dirt collection chamber(s) may be referred to generally as a second stage dirt collection region. Accordingly, while in the illustrated example each second stage dirt outlet **128a**, **128b** has its own associated second stage dirt collection chamber **128a**, **128b**, this need not be the case. For example, interior wall **440** may have one or more apertures, or may be omitted entirely, resulting in two or more second stage dirt outlets being in communication with a shared second stage dirt collection chamber.

Optionally, the cyclone assembly may include a removable pre-motor filter which may be in a removable pre-motor filter sub-assembly or section, shown generally as **490**. The pre-motor filter assembly may be any assembly known in the art or disclosed herein. In the illustrated embodiment, section **490** is shown as part of removable cyclone assembly **100**. Alternatively, pre-motor filter section **490** may not be removable concurrently with cyclone assembly **100**, e.g. it may be fixed to surface cleaning apparatus **10**.

As exemplified in FIGS. **33-35**, air exiting the second stage air outlet **124** is directed into a chamber or header or manifold **437** bounded by the lower surface **134** of the lower end wall **130** and an upstream face of a pre-motor filter **492**. From there, the air is drawn through the filter **492** into a chamber or header or manifold **447** bounded by the inner surface **494** of the housing of section **490** and a downstream face of pre-motor filter **492**, and subsequently exhausted out through the air outlet **434**.

In the illustrated example, the chambers or headers or manifolds **437** and **447** facilitate lateral airflow out of and into air outlets **124**, **434**, respectively. In such an arrangement, the upstream face of the pre-motor filter may have a surface area that is greater than the surface area of air outlet **124**, and the downstream face of the pre-motor filter may have a surface area that is greater than the surface area of air outlet **434**. An advantage of this design is that backpressure through the surface cleaning apparatus may be reduced.

As exemplified, the chambers or headers or manifolds **437** and **447** cooperatively define a pre-motor filter chamber that houses pre-motor filter **492**. In such a construction, the pre-motor filter chamber may be opened when the sub-assembly or section **490** is removed from cyclone bin assembly **100**. An advantage of this design is that when a user removes or separates the cyclone bin assembly from sub-assembly **490** (e.g. to empty the dirt collection chamber(s)), the user may also inspect the condition of the pre-motor filter. The pre-motor filter **492** may be any suitable type of porous filter media, such as a foam filter and/or a felt filter, or any other suitable pre-motor porous filter media(s) known in the art. Preferably, pre-motor filter **492** is removable to allow a user to clean and/or replace the filter when it is dirty.

Cyclone Assembly with Inverted Cyclonic Cleaning Stages

The following is a description of a cyclone assembly that may be used by itself in any surface cleaning apparatus or in any combination or sub-combination with any other feature or features disclosed herein including the sizing of a second stage cyclone compared to a first stage cyclone, and the connection of the second stage cyclone chamber air outlets with an upstream chamber of a pre-motor filter.

FIGS. **40-46** exemplify another embodiment of a cyclone assembly, referred to generally as **100**. Elements having similar structure and/or performing similar function as those

in the example cyclone assembly illustrated in FIGS. 31 to 39 are numbered similarly, and will not be discussed further. In the illustrated embodiment, the first cyclonic cleaning stage includes a first stage cyclone chamber 110 arranged in a generally vertical, inverted cyclone orientation, and the second cyclonic cleaning stage includes a second stage cyclone chamber 120 arranged in a generally vertical, inverted cyclone orientation.

As exemplified in FIGS. 42 to 44, air exiting the first stage air outlet 114 may be directed into a flow region that extends around an air inlet end of the second cyclonic cleaning stage. Where, as in the illustrated example, the air inlet end of the second cyclonic cleaning stage comprises a generally annular array of air inlets, the flow region may be characterized as an annular flow region. In the illustrated example, the annular flow region includes a chamber or manifold 117 that directs airflow into an annular inlet region 327. In the illustrated example, annular inlet region is bounded by a portion of the lower end wall 113 of the first stage cyclone chamber 110, a sidewall 507, and a portion of end wall 132. From annular inlet region 327, the air is directed into the second cyclonic cleaning stage through two or more air flow passages or air inlets. In the illustrated embodiment, the second cyclonic cleaning stage includes a single second stage cyclone chamber 120 arranged parallel to the first stage cyclone chamber 110 (i.e. cyclone axes 115 and 125 are generally parallel).

In the illustrated embodiment, the air inlets of the second stage cyclone chamber (i.e. air inlets 122a-122d) are positioned radially equidistantly at the inlet end of the second cyclonic cleaning stage (see e.g. FIG. 40). Alternatively, the air inlets of the second cyclonic stage may be arranged in any suitable manner. Also, while four second stage air inlets are illustrated, it will be appreciated that, alternatively, two or three or five or more second stage air inlets may be provided.

Also, in the illustrated embodiment, the annular flow region (which includes the annular inlet region 327 and manifold 117) extends axially and has first and second axially spaced apart ends. The first axially spaced apart end of the annular flow region is located a first distance from an axial end of the second stage cyclone chamber having the second cyclonic stage air inlets. In the illustrated embodiment, this first distance is effectively zero, as the axial end of the second stage cyclone chamber having the second cyclonic stage air inlets (e.g., the lower end of the second stage cyclone chamber of FIG. 44) extends from upper surface 132 of end wall 130, and upper surface 132 is also an axially spaced apart end of the annular flow region. The second axially spaced apart end of the annular flow region (e.g. the upper end of manifold 117) is axially located farther from the axial end of the second stage cyclone than the first distance. Further, the first cyclonic stage air outlet 114 is axially located proximate the second axially spaced apart end. Accordingly, the height of the inlets 122 and passages 123 may be about the same as the axial height of the annular inlet region 327, and the manifold 117 may be axially offset from the annular inlet region 327, which may reduce back pressure through the cyclone assembly.

Optionally, the cyclone assembly includes a removable pre-motor filter sub-assembly or section, shown generally as 490.

Latching Mechanism

The following is a description of a dual opening latching mechanism that may be used by itself in any surface cleaning apparatus or in any combination or sub-combination with any other feature or features disclosed herein

including the sizing of a second stage cyclone compared to a first stage cyclone, the positioning of a dirt collection region for second stage cyclones and the connection of the second stage cyclone chamber air outlets with an upstream chamber of a pre-motor filter.

In accordance with this feature, a latching mechanism with a multi-position switch or release mechanism may be provided to selectively retain the intermediate wall 140 and/or the upper end wall 150 in its respective closed position. An advantage of this design is that it may prevent a user from inadvertently opening both the intermediate wall 140 and the upper end wall 150 at the same time.

As exemplified in FIGS. 16-22, a latching mechanism, referred to generally as 200, is provided between the intermediate wall 140 and the upper end wall 150. Latching mechanism 200 includes an upper latch for selectively retaining upper end wall 150 in its closed position, and a lower latch for selectively retaining intermediate end wall 140 in its closed position. A release switch 260 is provided for selectively disengaging the upper latch or the lower latch.

Release switch 260 is an actuator that is moveable in two different directions, (e.g., left and right). When the actuator is moved in a first direction, a first locking member is moved to an unlocked position while a second locking member is maintained in a locked position. When the actuator is moved in a second direction, which may be an opposite direction to the first direction, the second locking member is moved to an unlocked position while the first locking member is maintained in a locked position. It will be appreciated that the first and second locking members may be separate elements or they may be opposite ends of a single linkage.

As exemplified in FIGS. 17, 19, and 22, the upper latch includes a generally U-shaped latching bar 220 that is pivotally coupled to a shaft 210. Shaft 210 is parallel to both the intermediate wall 140 and the upper end wall 150. The upper end of the latching bar 220 has a downwardly facing surface 224 that is configured to engage with a lip or flange 225 extending from the upper end wall 150 to cooperatively retain the end wall 150 in its closed position. When the latching bar 220 is in a locked position (as shown in FIGS. 17 and 22) and upper end wall 150 in its closed position, downwardly facing surface 224 overlies flange 225, thereby retaining upper end wall 150 in its closed position. Preferably, latching bar 220 is biased towards its locked position, for example, using a spring or other biasing member(s) (not shown).

The upper end of the latching bar 220 also has an upwardly facing angled or beveled surface 222 that is configured to pivot the latching bar 220 away from the locked position when engaged by an angled or beveled surface 223 of flange 225, thereby allowing the upper latch to be engaged by bringing the end wall 150 to its closed position.

Latching bar 220 also has a flange or projection 226 that extends generally forwardly. As shown in FIG. 17, projection 226 is angled or sloped such that one lateral end of the projection 226 extends further forward than the opposite lateral end.

As exemplified in FIGS. 19, 21, and 22, the lower latch includes a latching bar 240 that is also pivotally coupled to shaft 210. The lower end of latching bar 240 has an upwardly facing surface 244 that is configured to engage with a lip or flange 245 extending from the outer sidewall 108 to cooperatively retain the intermediate wall 140 in its closed position. When the latching bar 240 is in a locked position (as shown in FIGS. 19 and 21) and intermediate

wall **140** in its closed position, upwardly facing surface **244** overlies flange **245**, thereby retaining intermediate wall **140** in its closed position. Preferably, latching bar **240** is biased towards its locked position, for example, using a spring or other biasing member(s) (not shown).

The lower end of the latching bar **240** also has a downwardly facing angled or beveled surface **242** that is configured to pivot the latching bar **240** away from its locked position when engaged by an angled or beveled surface **243** of flange **245**, thereby allowing the lower latch to be engaged by bringing the intermediate wall **140** to its closed position.

Latching bar **240** also has a flange or projection **246** that extends generally forwardly. As exemplified in FIGS. **17** and **21**, projection **246** is angled or sloped such that one lateral end of the projection **246** extends further forward than the opposite lateral end. Notably, projections **246** and **226** are angled in opposite directions. This arrangement facilitates the selective unlatching of either the upper or lower latch using a single multi-position switch or release mechanism.

As exemplified in FIG. **16**, the release switch **260** for latching mechanism **200** is rotatably or pivotally coupled to a shaft **270**. Shaft **270** is generally perpendicular to both the intermediate wall **140** and the upper end wall **150**. Release switch **260** also includes an outwardly facing projection or tab **262** to facilitate a user's rotation of switch **260** about shaft **270**. Release switch **260** also includes an inwardly facing flange or projection **264** that is configured to engage the projections **226**, **246** of the upper and lower latching bars **220**, **240**, respectively.

As exemplified in FIGS. **16**, **17** and **21**, the release switch **260** is shown in a neutral position. In this position, inwardly facing projection **264** is not in contact with either projection **226** or projection **246**. As the release switch **260** is pivoted towards the position shown in FIG. **18**, projection **264** is brought into abutment with projection **226** of the upper latching mechanism. Further pivoting of release switch **260** forces the upper latching bar **220** away from its locked position, and thereby unlatching the upper latch (as shown in FIG. **19**) and permitting the upper end wall **150** to be moved to an open position.

Alternatively, if the release switch **260** is pivoted towards the position shown in FIG. **20**, projection **264** is brought into abutment with projection **246** of the lower latching mechanism. Further pivoting of release switch **260** forces the lower latching bar **240** away from its locked position, and thereby unlatching the lower latch (as shown in FIG. **22**) and permitting the intermediate wall **140** to be moved to an open position.

It will be appreciated that some of the embodiments disclosed herein may not use any of the features of the latching mechanisms disclosed herein and that, in those embodiments, mechanisms for retaining the intermediate and upper walls in their closed positions may be of various constructions and that in those embodiments any latching or retaining mechanism known in the art may be used.

Air Outlets for Second Stage Cyclones Provided in a Wall of Common Manifold, Which May be a Pre-Motor Filter Chamber

The following is a description of the connection of the second stage cyclone chamber air outlets with an upstream chamber of a pre-motor filter for the second cyclonic cleaning that may be used by itself in any surface cleaning apparatus or in any combination or sub-combination with any other feature or features disclosed herein including the sizing of a second stage cyclone compared to a first stage

cyclone, the positioning of a dirt collection region for second stage cyclones and a dual opening latching mechanism.

In accordance with this feature, the air outlets of a plurality of cyclone chambers that are connected in parallel may be connected directly to an upstream pre-motor filter chamber or manifold. Accordingly, some or all of the air outlets may extend to opening provided in the manifold. Accordingly, a manifold for the air outlets, which is upstream from the pre-motor filter chamber, is not provided.

Optionally, the upstream pre-motor filter chamber or manifold may be positioned in facing relationship with the air outlets of a plurality of cyclone chambers that are connected in parallel. Accordingly, the upstream face of the pre-motor filter may be positioned generally transverse to the axis of the cyclone air outlets, and the axis of the cyclone air outlets may be generally parallel to the cyclone of which they are the air exits. Therefore, for example, the manifold may be positioned below a second cyclonic cleaning stage and each of the second stage cyclone air outlets may have an outlet end in a wall of the chamber or manifold. An advantage of this design is that fewer conduit walls and/or ducting may be required to direct airflow from the second cyclonic cleaning stage towards the suction unit, which may simplify the design and/or construction of the cyclone assembly and/or surface cleaning apparatus, and/or may reduce backpressure through the surface cleaning apparatus.

As exemplified in FIGS. **9-11**, air exiting the second stage air outlets **124a-f** is directed into a chamber or header or manifold **27** bounded by the lower surface **134** of the lower end wall **130** of cyclone assembly **100** and the upper end of the suction unit **20**. From there, the air is directed by the suction motor through the suction unit **20** and subsequently exhausted out through the clean air outlet **18**.

In alternative embodiments, cyclone assembly **100** may include one or more additional manifolds downstream of the second stage air outlets **124a-f** so that cyclone assembly **100** has a single assembly air outlet or fewer air outlets than there are second stage cyclone chambers.

As exemplified, the chamber or header or manifold is a pre-motor filter chamber that houses a pre-motor filter. In such a construction, the pre-motor filter chamber may be opened when the cyclone bin assembly is removed. For example, the cyclone bin assembly may form part of the pre-motor filter chamber (e.g., an upstream wall of the pre-motor filter chamber). An advantage of this design is that the pre-motor filter chamber is opened when the cyclone bin assembly is removed. Accordingly, when a user removes the cyclone bin assembly (e.g. to empty the dirt collection chamber(s)), the user may also inspect the condition of the pre-motor filter. The pre-motor filter may be any suitable type of porous filter media, such as a foam filter and/or a felt filter, or any other suitable pre-motor porous filter media(s) known in the art. Preferably, the pre-motor filter is removable to allow a user to clean and/or replace the filter when it is dirty.

Typically, a pre-motor filter is provided to prevent particulate matter that is not removed from the airstream by the cyclonic cleaning stages from being drawn into the suction motor. Otherwise, this unremoved particulate matter may cause damage to (or otherwise impair) the suction motor.

While the use of a pre-motor filter may be effective at protecting the suction motor, there may be one or more disadvantages. For example, the pre-motor filter may become clogged with particulate matter, requiring a user to clean and/or replace the filter, a task a user may regard as undesirable.

As used herein, the wording "and/or" is intended to represent an inclusive-or. That is, "X and/or Y" is intended to mean X or Y or both, for example. As a further example, "X, Y, and/or Z" is intended to mean X or Y or Z or any combination thereof.

While the above description describes features of example embodiments, it will be appreciated that some features and/or functions of the described embodiments are susceptible to modification without departing from the spirit and principles of operation of the described embodiments. For example, the various characteristics which are described by means of the represented embodiments or examples may be selectively combined with each other. Accordingly, what has been described above is intended to be illustrative of the claimed concept and non-limiting. It will be understood by persons skilled in the art that other variants and modifications may be made without departing from the scope of the invention as defined in the claims appended hereto. The scope of the claims should not be limited by the preferred embodiments and examples, but should be given the broadest interpretation consistent with the description as a whole.

The invention claimed is:

1. A vacuum cleaner having a cyclone assembly, the cyclone assembly comprising:

(a) a first cyclonic cleaning stage comprising a first stage cyclone having a first stage cyclone chamber, a first stage cyclone axis, a first cyclonic stage air inlet, a first cyclonic stage air outlet and a first cyclonic stage air outlet end; and,

(b) a second cyclonic cleaning stage downstream from the first cyclonic cleaning stage and comprising a second stage cyclone having a second stage cyclone chamber, a second stage cyclone axis, a plurality of second cyclonic stage cyclone air inlets, a second cyclonic stage air inlet end and an axially opposed second cyclonic stage second end;

wherein the plurality of second cyclonic stage cyclone air inlets have a second stage air inlet cross-sectional area in a direction transverse to a direction of air flow travelling through the second cyclonic stage cyclone air inlets that is 1.1-2 times larger than a first stage air inlet cross-sectional area in a direction transverse to a direction of air flow travelling through the first cyclonic stage air inlet.

2. The vacuum cleaner of claim 1 wherein the first cyclonic stage air outlet is located at the second cyclonic stage cyclone air inlet end.

3. The vacuum cleaner of claim 1 further comprising a single header extending around the plurality of second cyclonic stage cyclone air inlets.

4. The vacuum cleaner of claim 1 wherein a second cyclonic stage air outlet is located at the axially opposed second cyclonic stage second end.

5. The vacuum cleaner of claim 1 wherein the cyclone assembly comprises a single first stage cyclone chamber and a single second stage cyclone chamber.

6. The vacuum cleaner of claim 1 wherein the cyclone assembly comprises a single first stage cyclone chamber and a plurality of second stage cyclone chambers.

7. The vacuum cleaner of claim 1 wherein the second stage air inlet cross-sectional area is 1.1 1.3 times larger than the first stage air inlet cross-sectional area.

8. The vacuum cleaner of claim 1 wherein the plurality of second stage air inlets has a second stage air inlet cross-sectional flow area, taking into account boundary layer losses, that is approximately equal to a first stage air inlet cross-sectional flow area, taking into account boundary layer losses, of the first cyclonic stage air inlet.

9. A vacuum cleaner having a cyclone assembly, the cyclone assembly comprising:

(a) a first cyclonic cleaning stage comprising a first stage cyclone axis, a first cyclonic stage air outlet and a first cyclonic stage air outlet end; and,

(b) a second cyclonic cleaning stage downstream from the first cyclonic cleaning stage and comprising a second stage cyclone axis, a second cyclonic stage air inlet end and an axially opposed second cyclonic stage second end,

wherein the second cyclonic cleaning stage has more air inlets than the first cyclonic cleaning stage, and

wherein the second cyclonic cleaning stage has a second stage air inlet cross-sectional area in a direction transverse to a direction of air flow entering the second stage cyclone chamber that is 1.1-2 times larger than a first stage air inlet cross-sectional area in a direction transverse to a direction of air flow entering the first stage cyclone chamber.

10. The vacuum cleaner of claim 9 wherein the first cyclonic stage air outlet is located at the second cyclonic stage cyclone air inlet end.

11. The vacuum cleaner of claim 9 further comprising a single header extending around the plurality of second cyclonic stage cyclone air inlets.

12. The vacuum cleaner of claim 9 wherein a second cyclonic stage air outlet is located at the axially opposed second cyclonic stage second end.

13. The vacuum cleaner of claim 9 wherein the cyclone assembly comprises a single first stage cyclone chamber and a single second stage cyclone chamber.

14. The vacuum cleaner of claim 9 wherein the cyclone assembly comprises a single first stage cyclone chamber and a plurality of second stage cyclone chambers.

15. The vacuum cleaner of claim 14 wherein the first cyclonic stage air outlet is located at the second cyclonic stage cyclone air inlet end.

16. The vacuum cleaner of claim 15 further comprising a single header extending around the plurality of second cyclonic stage cyclone air inlets.

17. The vacuum cleaner of claim 16 wherein a second cyclonic stage air outlet is located at the axially opposed second cyclonic stage second end.

18. The vacuum cleaner of claim 9 wherein the second stage air inlet cross-sectional area is 1.1 1.3 times larger than the first stage air inlet cross-sectional area.

19. The vacuum cleaner of claim 9 wherein the second cyclonic cleaning stage has a plurality of second stage air inlets and the plurality of second stage air inlets has a second stage air inlet cross-sectional flow area, taking into account boundary layer losses, that is approximately equal to a first stage air inlet cross-sectional flow area, taking into account boundary layer losses.