



(12) **United States Patent**  
**Conrad**

(10) **Patent No.:** **US 10,806,317 B2**  
(45) **Date of Patent:** **\*Oct. 20, 2020**

- (54) **SURFACE CLEANING APPARATUS**
- (71) Applicant: **Omachron Intellectual Property inc.**, Hampton (CA)
- (72) Inventor: **Wayne Ernest Conrad**, Hampton (CA)
- (73) Assignee: **Omachron Intellectual Property Inc.**, Hampton, Ontario (CA)
- (\* ) Notice: Subject to any disclaimer, the term of this patent is extended or adjusted under 35 U.S.C. 154(b) by 281 days.  
  
This patent is subject to a terminal disclaimer.

- (21) Appl. No.: **16/039,962**
- (22) Filed: **Jul. 19, 2018**

- (65) **Prior Publication Data**  
US 2020/0022547 A1 Jan. 23, 2020

- (51) **Int. Cl.**  
**B01D 50/00** (2006.01)  
**A47L 9/16** (2006.01)  
(Continued)

- (52) **U.S. Cl.**  
CPC ..... **A47L 9/1616** (2013.01); **A47L 5/16** (2013.01); **A47L 9/0606** (2013.01); **A47L 9/1683** (2013.01); **B04C 5/04** (2013.01); **A47L 9/122** (2013.01); **A47L 9/165** (2013.01); **A47L 9/1608** (2013.01); **A47L 9/1625** (2013.01);  
(Continued)

- (58) **Field of Classification Search**  
CPC ..... A47L 9/1616; A47L 5/16; A47L 9/0606; A47L 9/1683; A47L 9/165; A47L 9/1691; A47L 9/246; A47L 9/2857; A47L 9/1666; A47L 9/1608; A47L 9/122; A47L 5/24; A47L 9/1625; Y10S 55/03; B04C 5/04  
See application file for complete search history.

(56) **References Cited**  
U.S. PATENT DOCUMENTS

7,065,826 B1 6/2006 Arnold  
7,662,201 B2 2/2010 Lee  
(Continued)

FOREIGN PATENT DOCUMENTS

CN 102429611 A 5/2012  
CN 106725109 A 5/2017  
(Continued)

OTHER PUBLICATIONS

English machine translation of EP2866630B1, published on Aug. 31, 2016.

(Continued)

*Primary Examiner* — Dung H Bui  
(74) *Attorney, Agent, or Firm* — Philip C. Mendes da Costa; Bereskin & Parr LLP/S.E.N.C.R.L., s.r.l.

(57) **ABSTRACT**

A surface cleaning apparatus has a first air flow path extending from a dirty air inlet to a clean air outlet with a suction motor and a cyclone positioned in the first air flow path. The cyclone has a cyclone chamber, a first airflow passage, and a second airflow passage. The first airflow passage defines a first tangential air inlet to the cyclone chamber and the second airflow passage defines a second tangential air inlet to the cyclone chamber. The airflow path includes a common airflow passage upstream of the first and second airflow passages and an axis of the common airflow passage intersects the cyclone chamber. At least a portion of the first tangential air inlet is positioned upstream from a location at which the common airflow passage axis intersects the cyclone chamber.

**21 Claims, 15 Drawing Sheets**

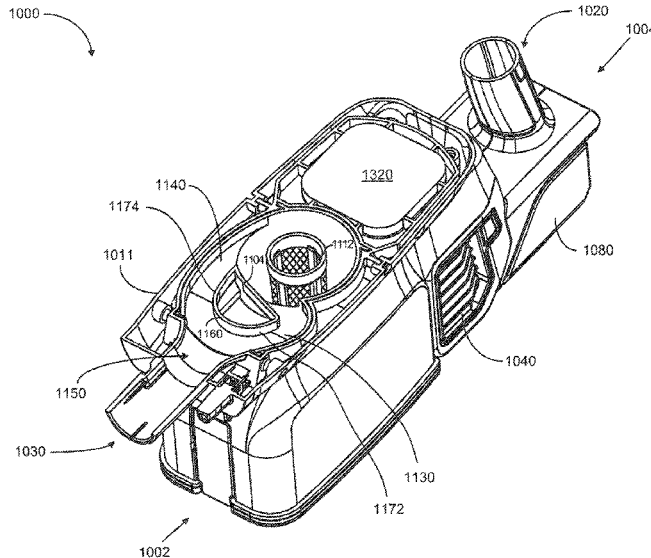

(51)	<b>Int. Cl.</b>			KR	100816911 B1	3/2008
	<i>A47L 5/16</i>	(2006.01)		KR	100880494 B1	1/2009
	<i>A47L 9/06</i>	(2006.01)		KR	10-1692736 B1	1/2017
	<i>B04C 5/04</i>	(2006.01)		WO	9835603 A1	8/1998
	<i>A47L 9/24</i>	(2006.01)		WO	2008114966 A1	9/2008
	<i>A47L 9/28</i>	(2006.01)		WO	2009011494 A1	1/2009
	<i>A47L 9/12</i>	(2006.01)		WO	2017171500 A1	10/2017
				WO	2017185175 A1	11/2017

(52) **U.S. Cl.**  
 CPC ..... *A47L 9/1666* (2013.01); *A47L 9/1691*  
 (2013.01); *A47L 9/24* (2013.01); *A47L 9/246*  
 (2013.01); *A47L 9/2857* (2013.01); *Y10S 55/03*  
 (2013.01)

OTHER PUBLICATIONS

English machine translation of CN102429611A, published on May 2, 2012.  
 English machine translation of CN106725109A, published on May 31, 2017.  
 English machine translation of KR100880494B1, published on Jan. 19, 2009.  
 English machine translation of CN102429611, published on May 2, 2012.  
 English machine translation of KR100816911B1, published on Mar. 19, 2008.  
 International Search Report and Written Opinion, received in connection to co-pending international patent application No. PCT/CA2019/050984, dated Oct. 10, 2019.  
 Total Patent: English machine translation of KR10-1692736, published on Jan. 4, 2017.  
 English machine translation of JP08-322769, published on Dec. 10, 2016, obtained through JP Patent Office search engine.

(56) **References Cited**

U.S. PATENT DOCUMENTS

7,771,499 B2	8/2010	Oh et al.
7,867,308 B2	1/2011	Conrad
2008/0104795 A1	5/2008	Lang
2009/0241491 A1	10/2009	Han et al.
2018/0177363 A1	6/2018	Ni

FOREIGN PATENT DOCUMENTS

EP	2866630 B1	8/2016
JP	08-322769 A	12/1996

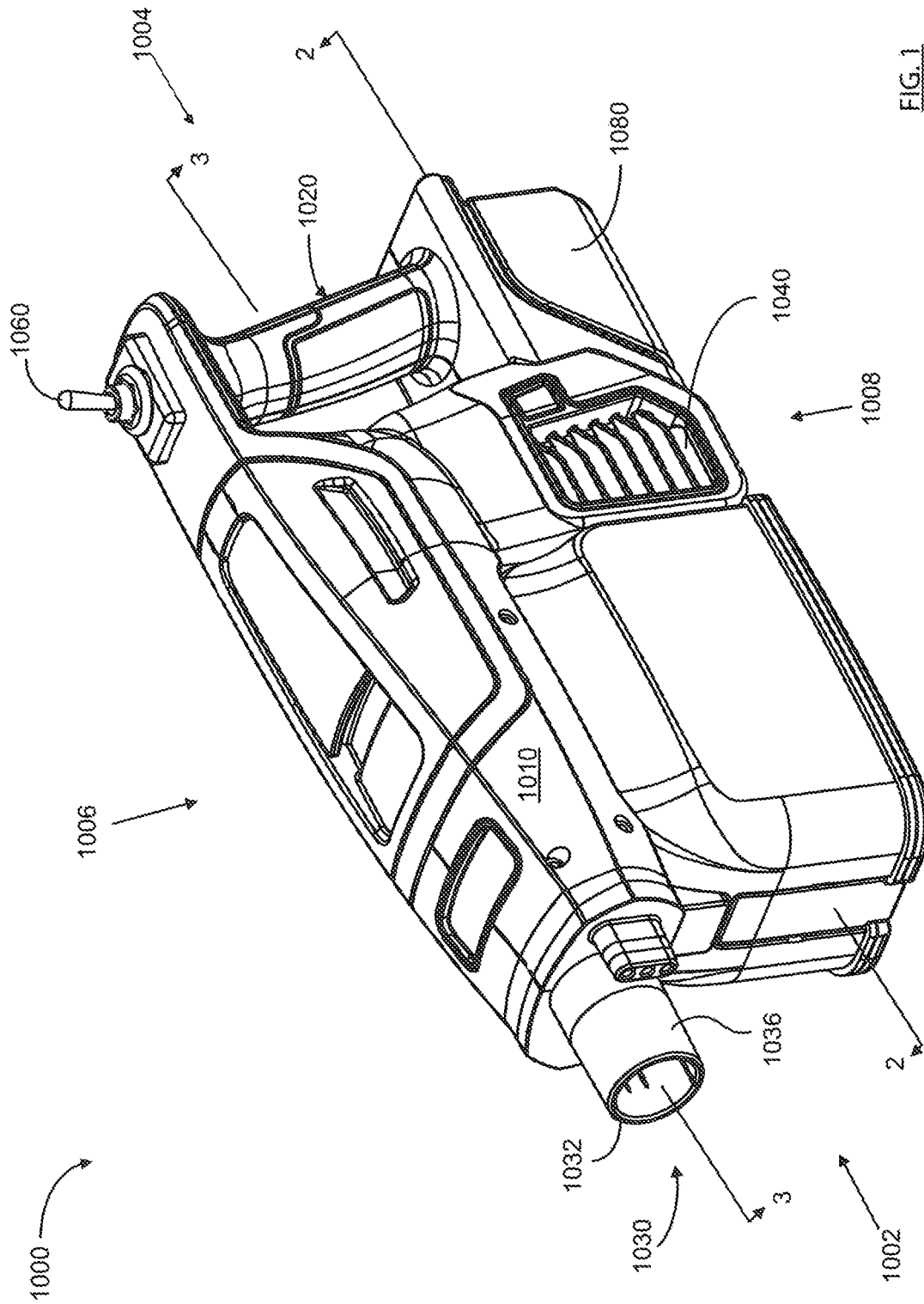

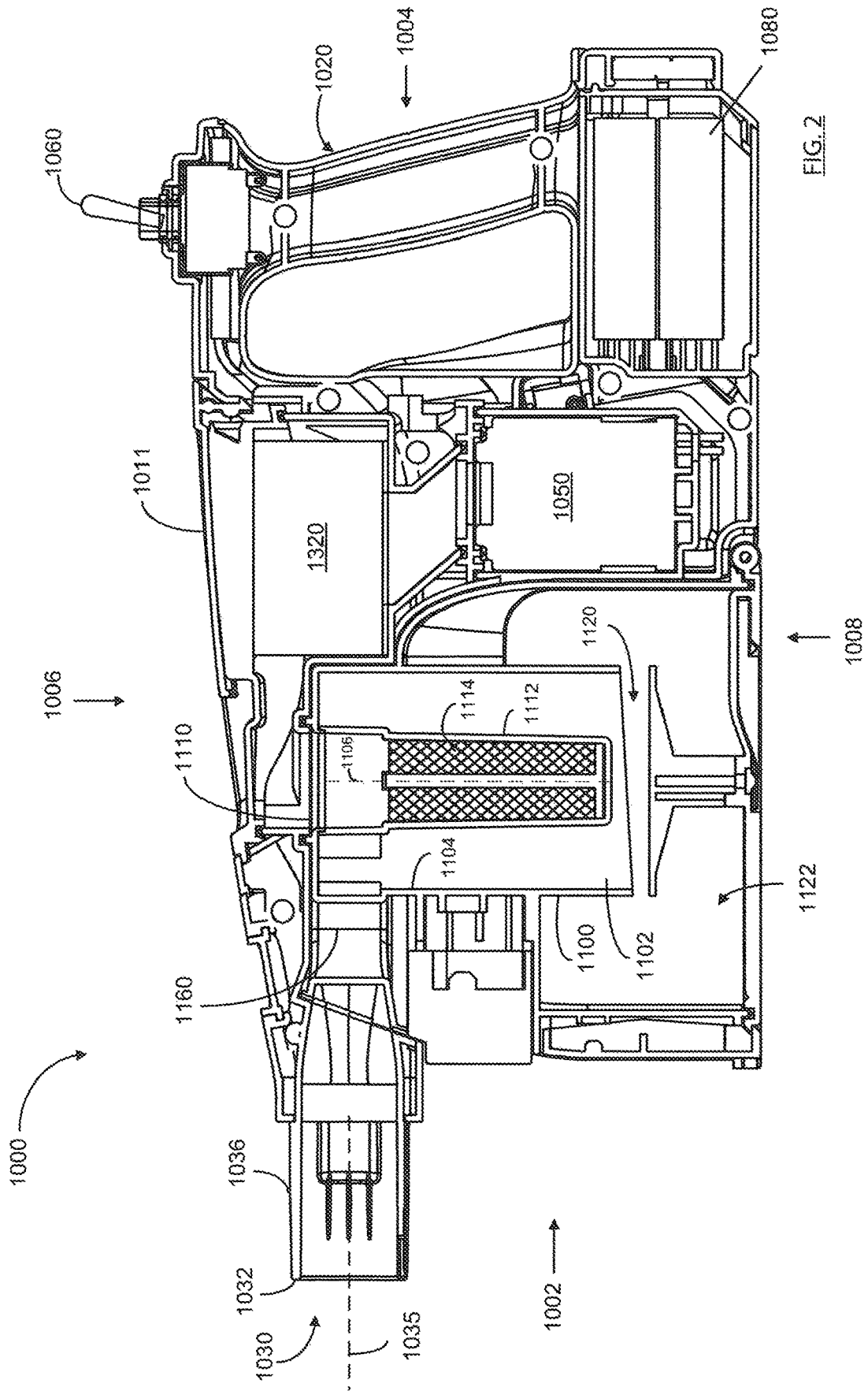

FIG. 2

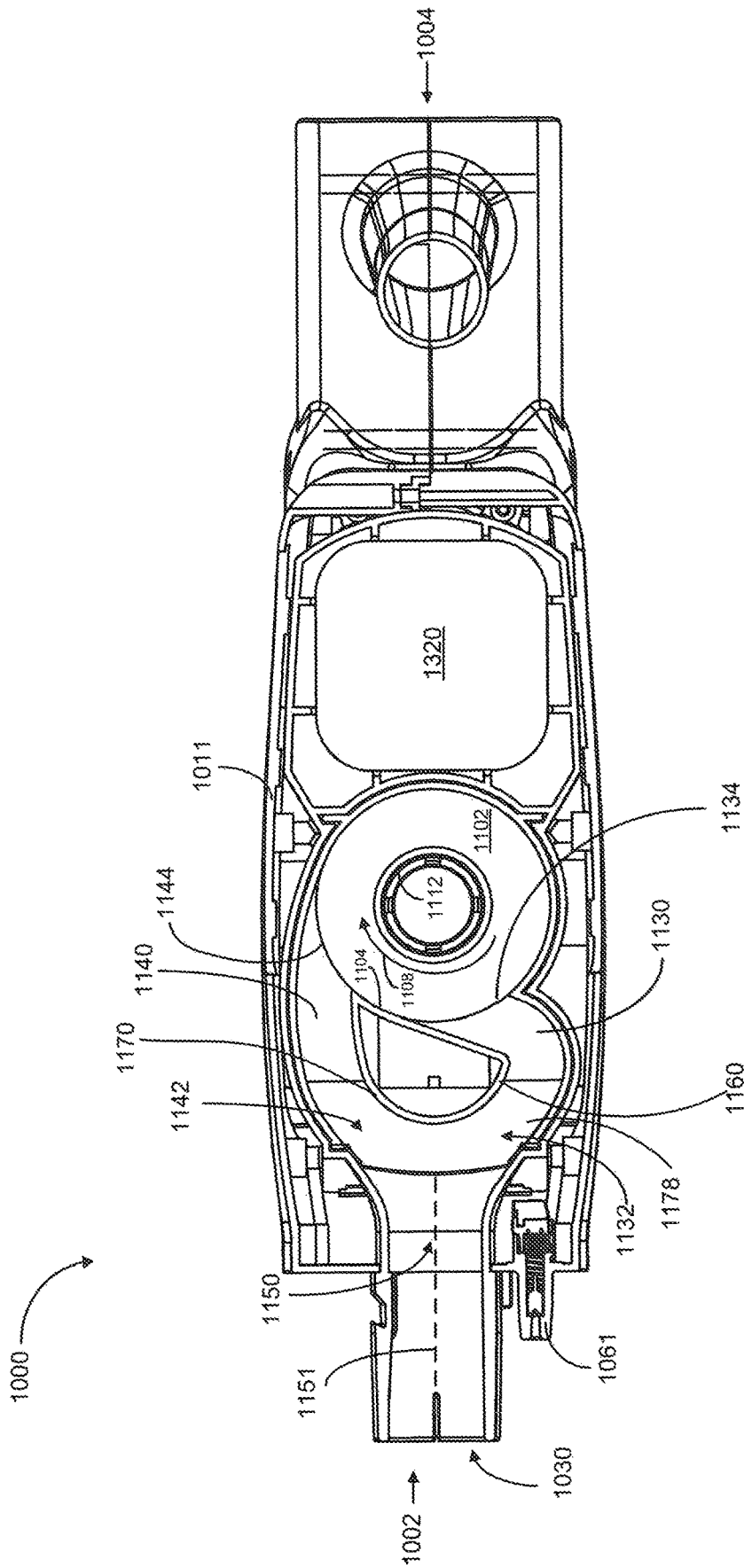

FIG. 3

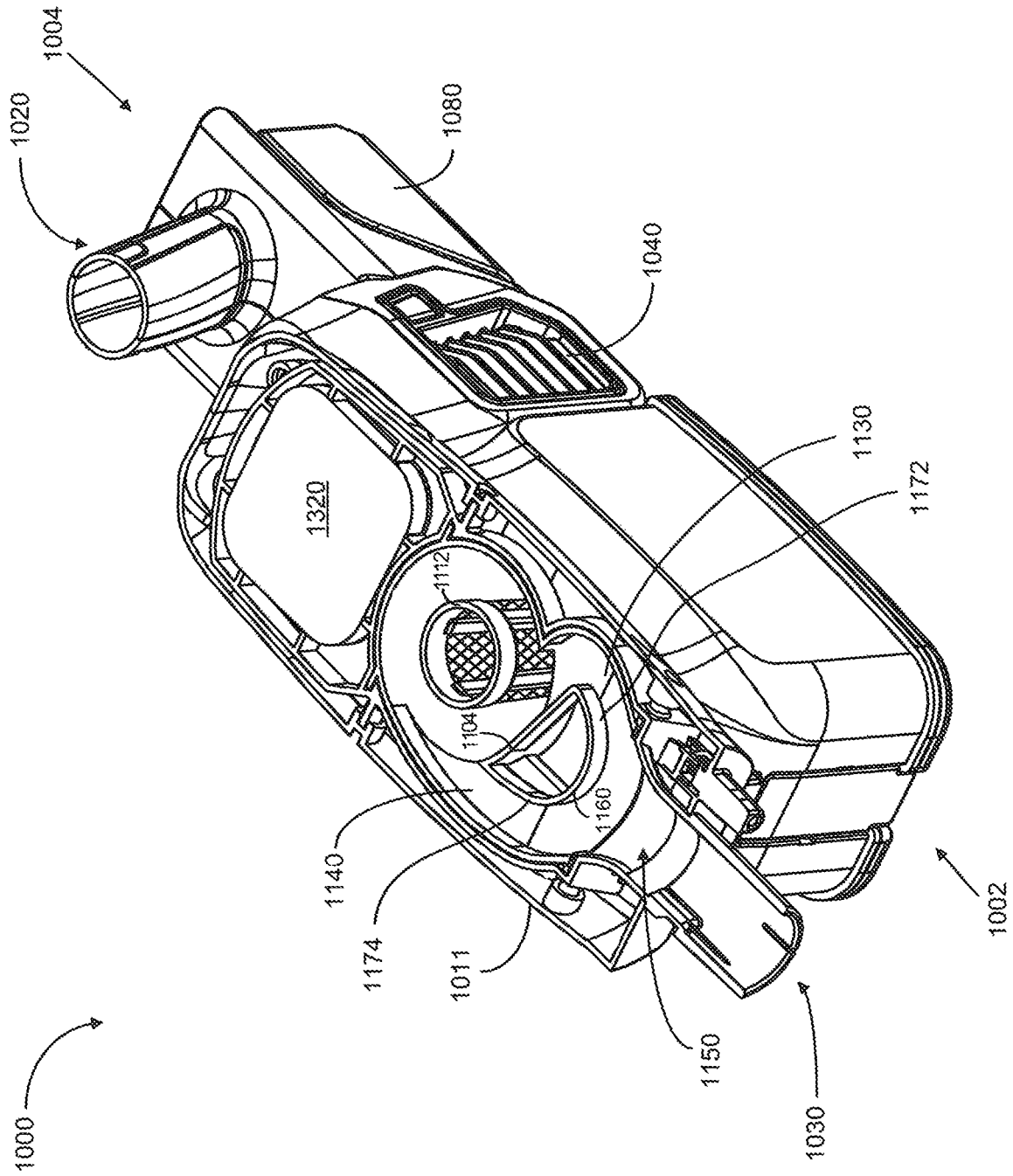
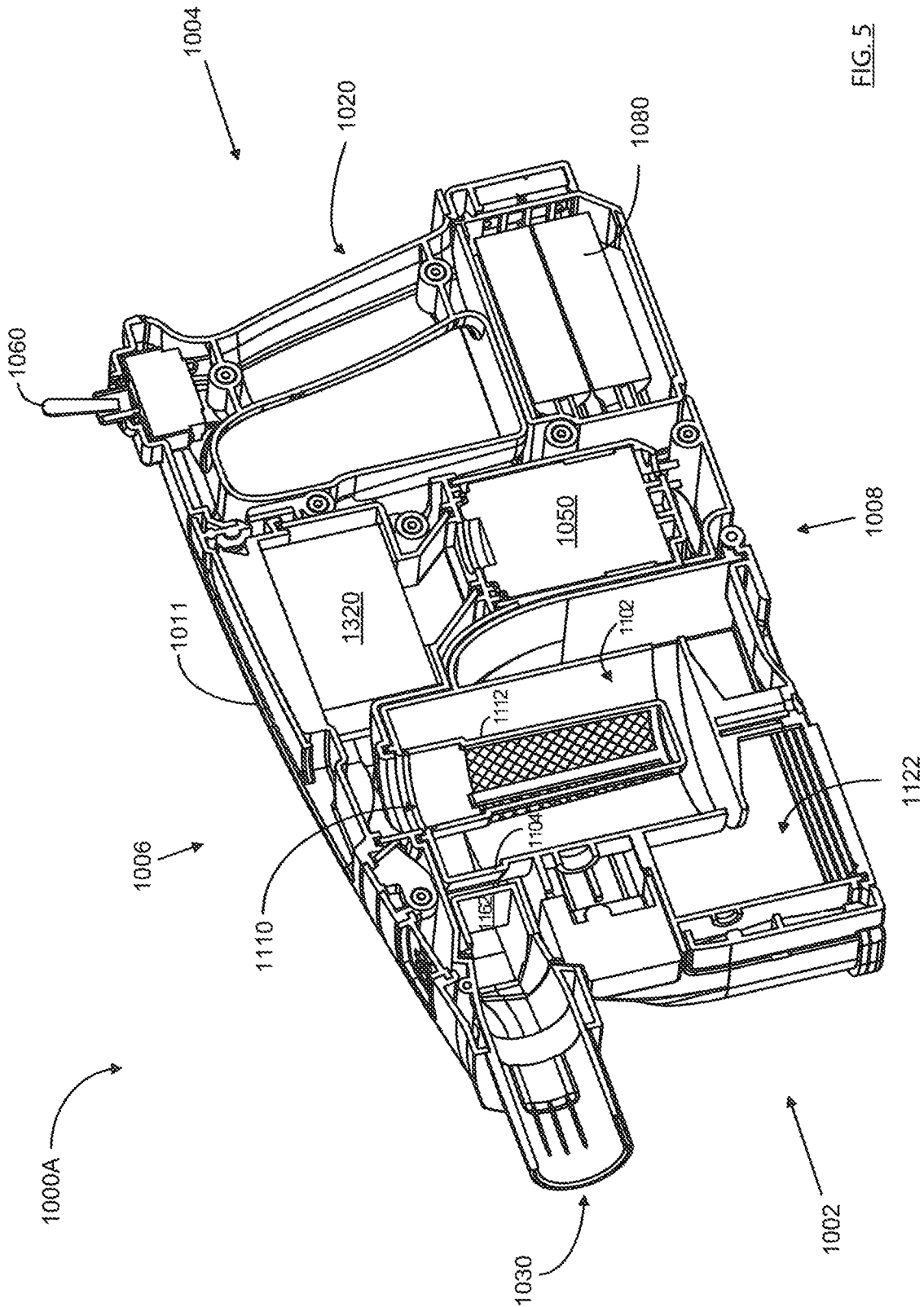

FIG. 4



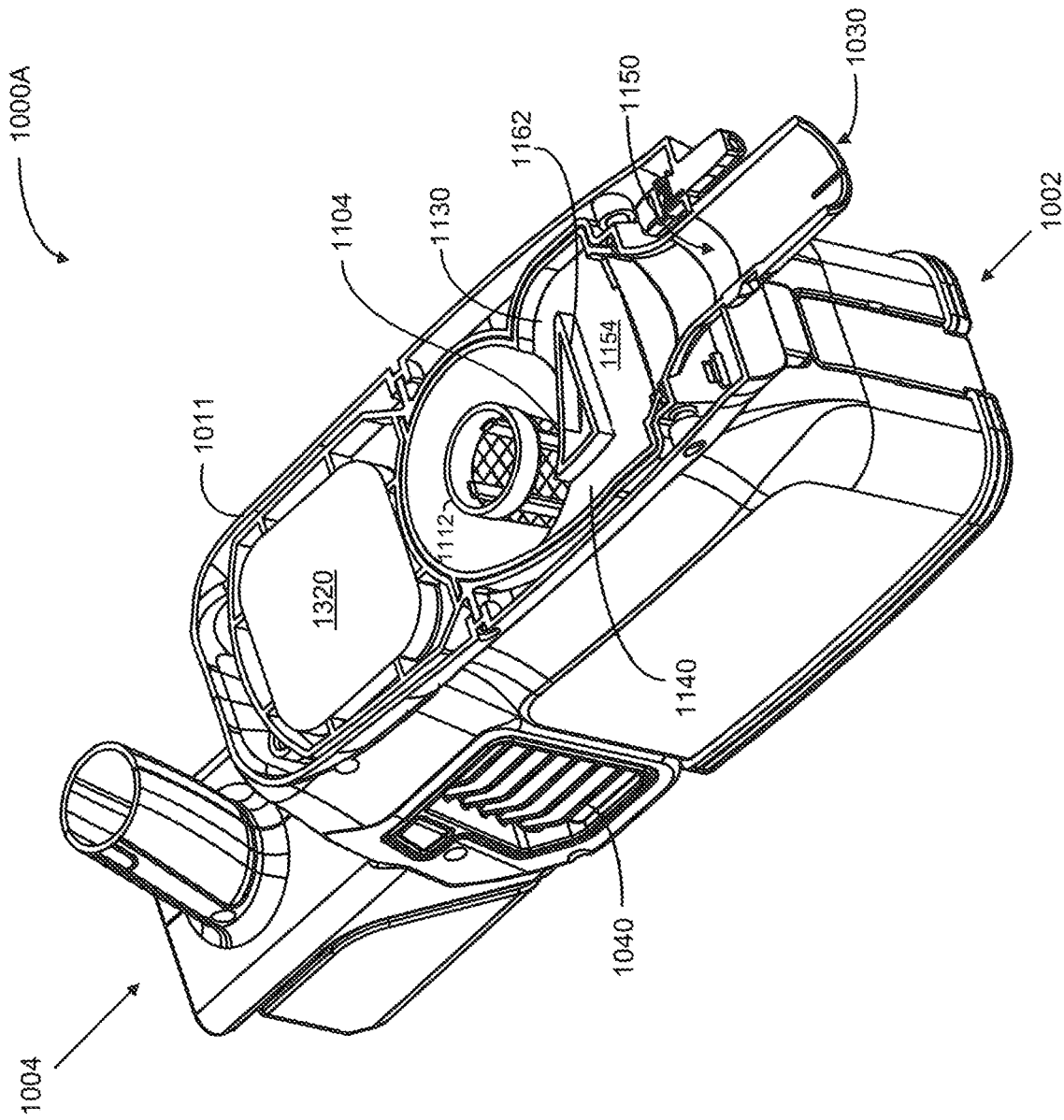

FIG. 6



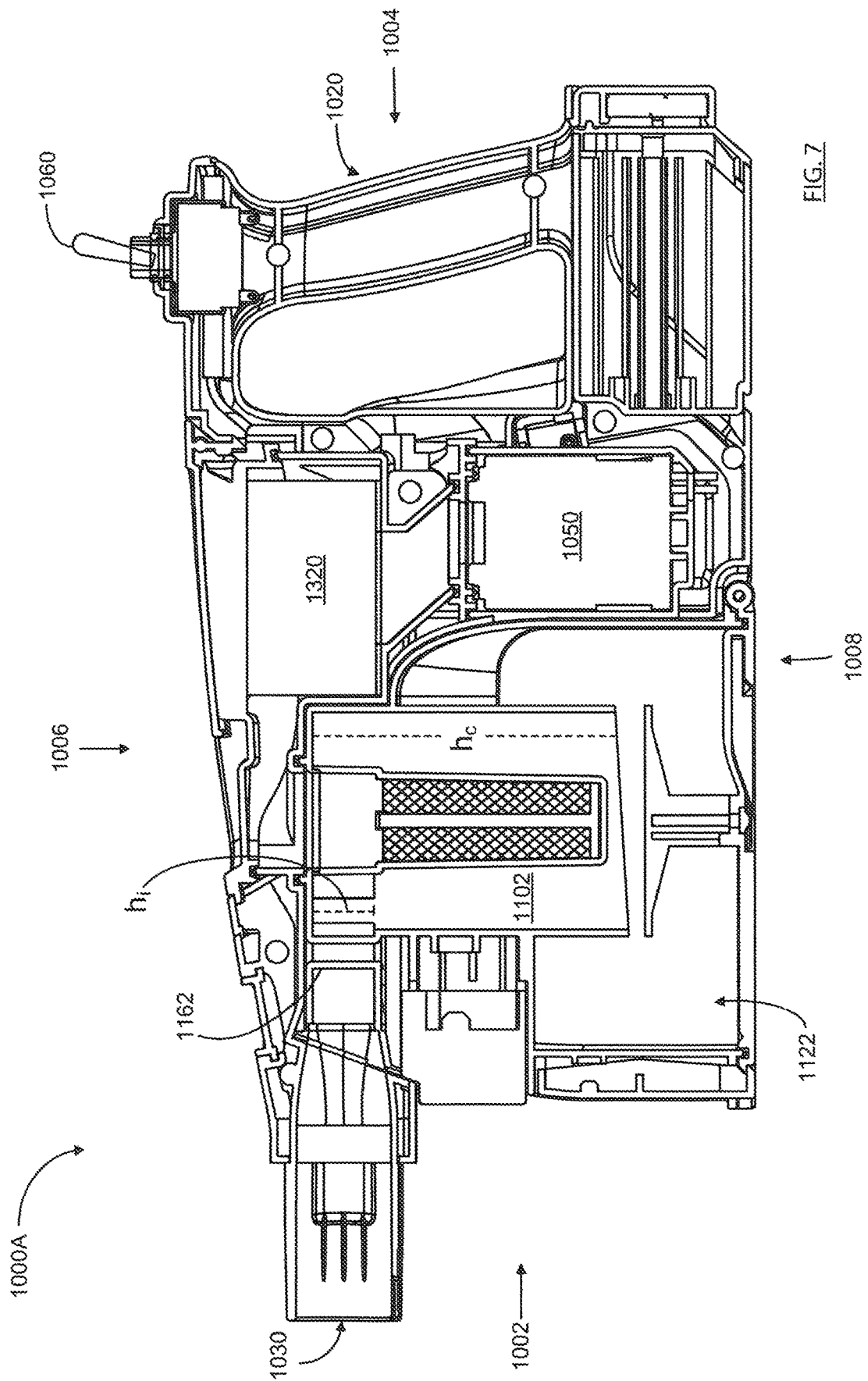

FIG. 7

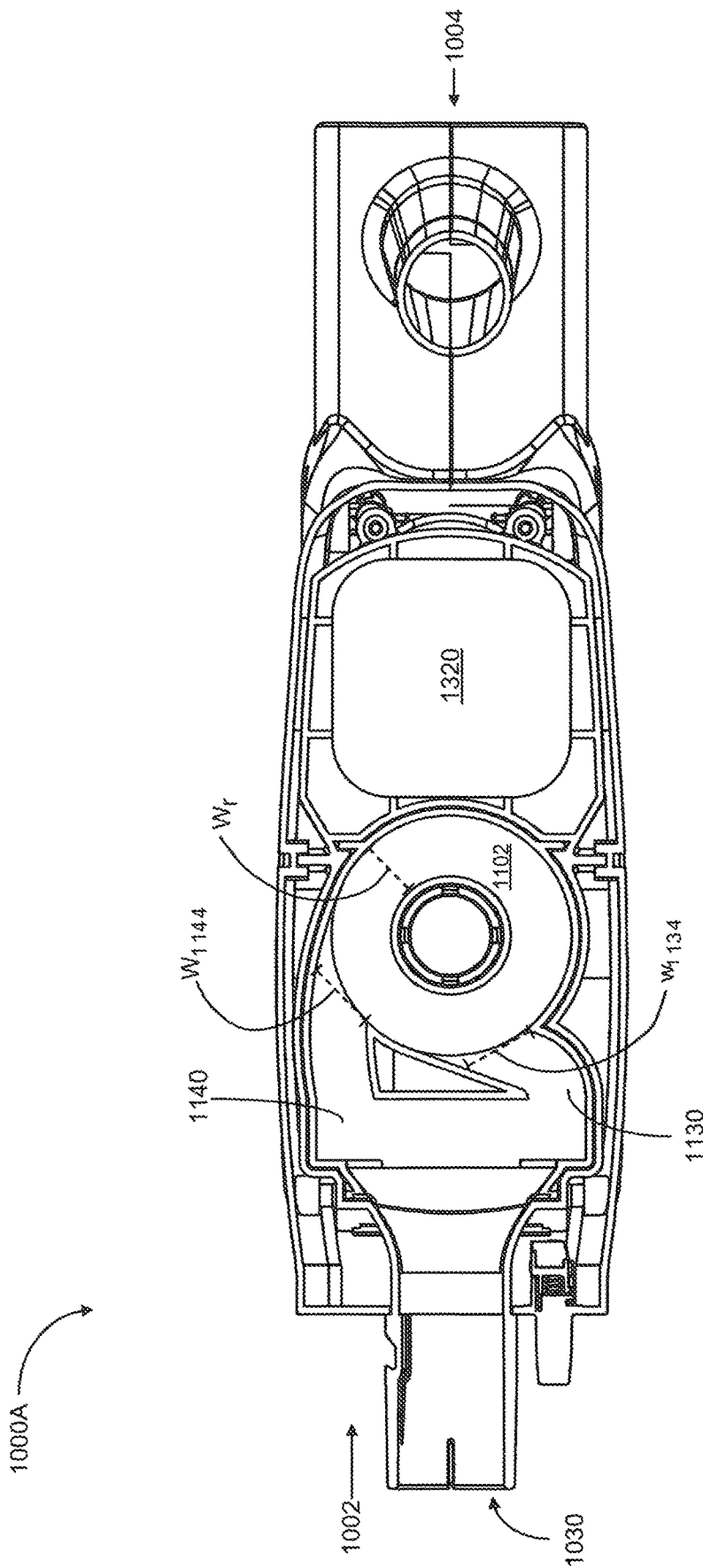

FIG. 8

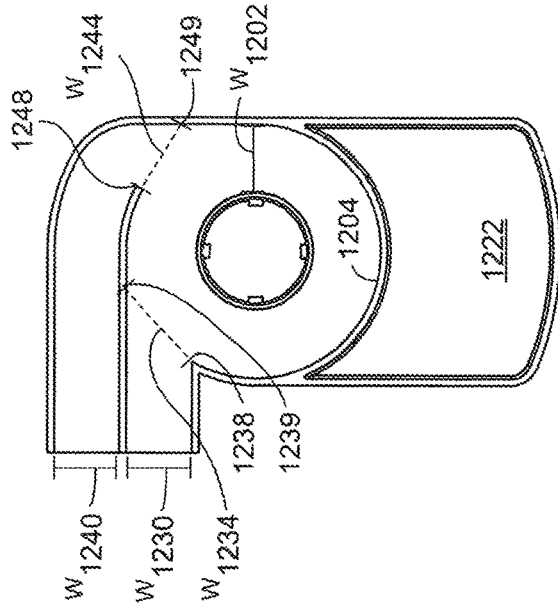

FIG. 9B

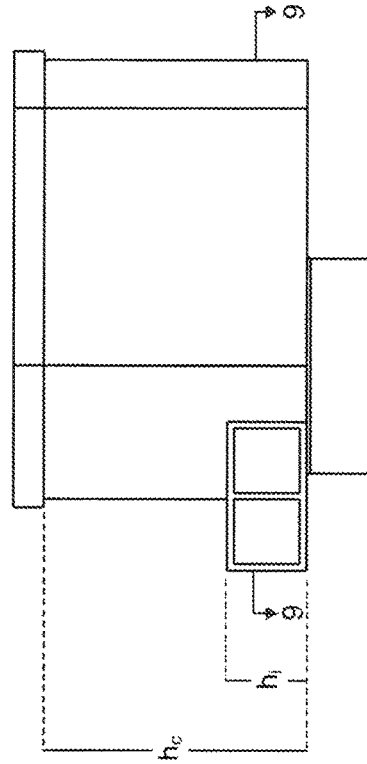

FIG. 9C

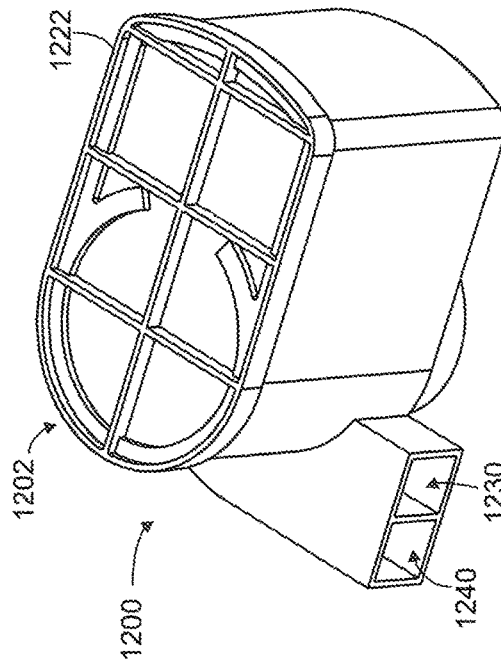
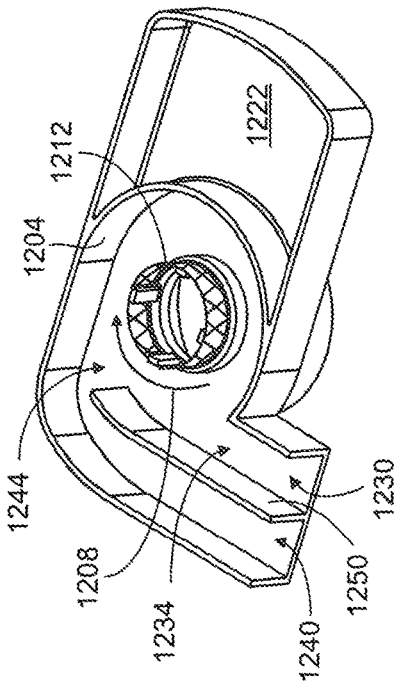

FIG. 9E

FIG. 9A

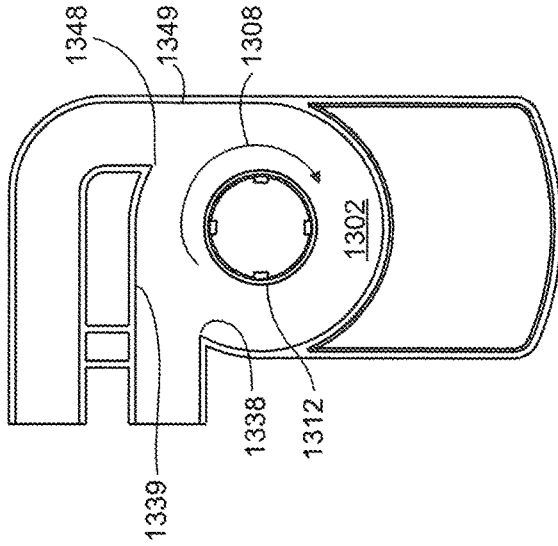

FIG. 10D

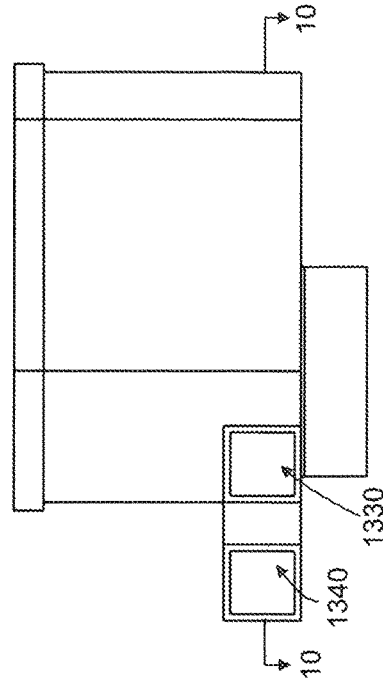

FIG. 10B

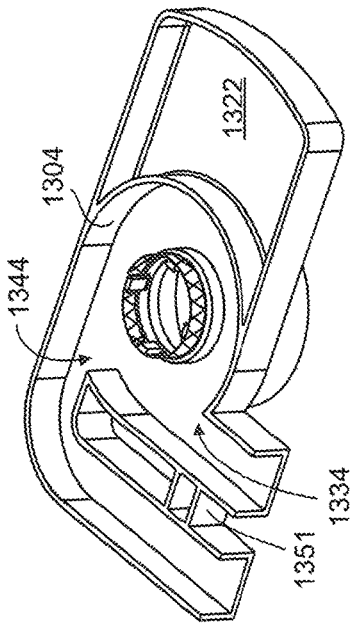

FIG. 10C

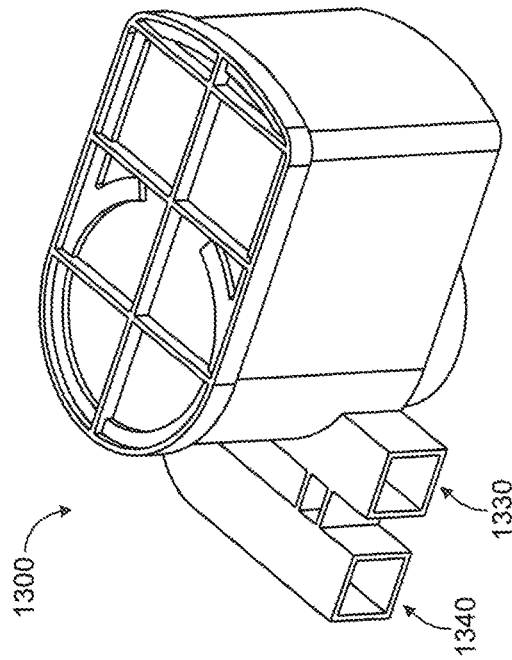

FIG. 10A

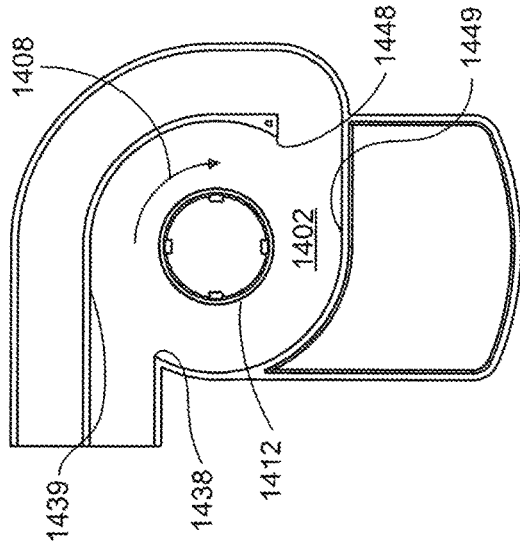

FIG. 11D

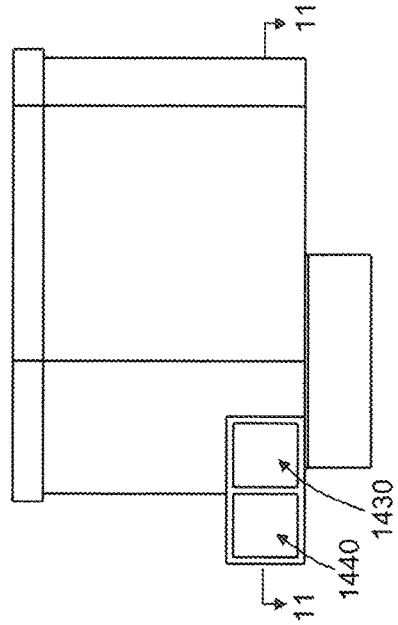

FIG. 11B

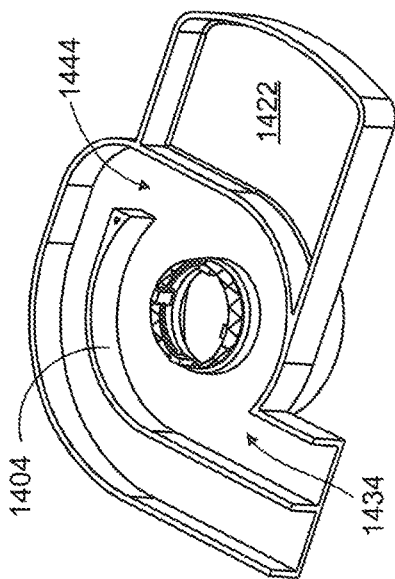

FIG. 11C

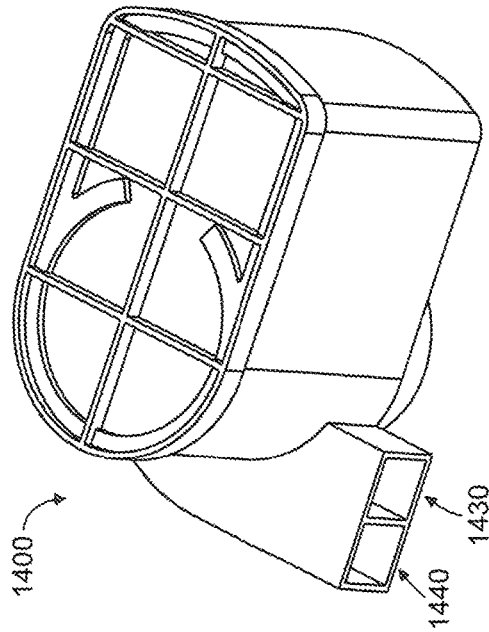

FIG. 11A

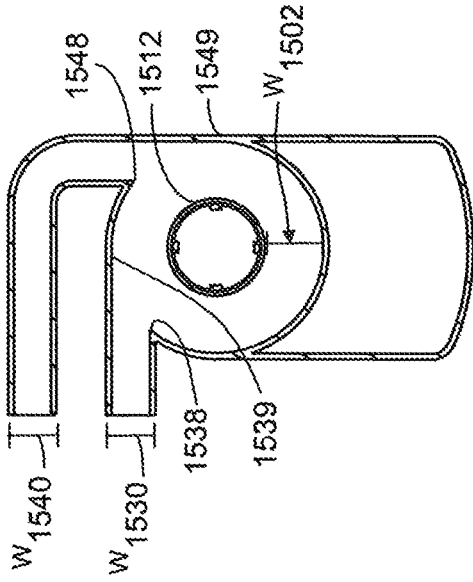

FIG. 12D

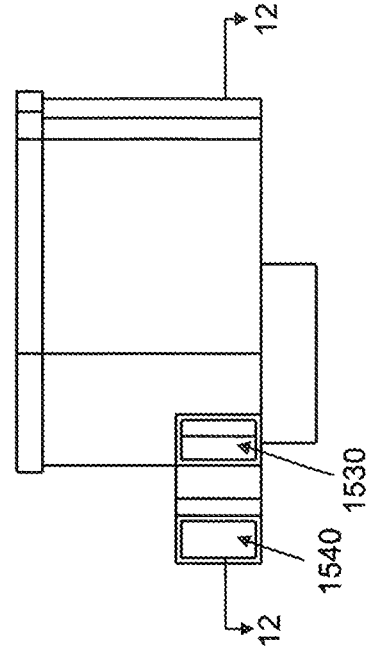

FIG. 12B

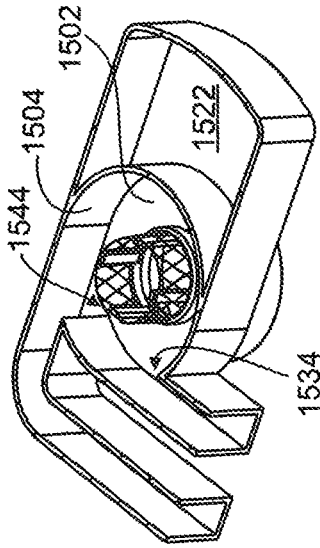

FIG. 12C

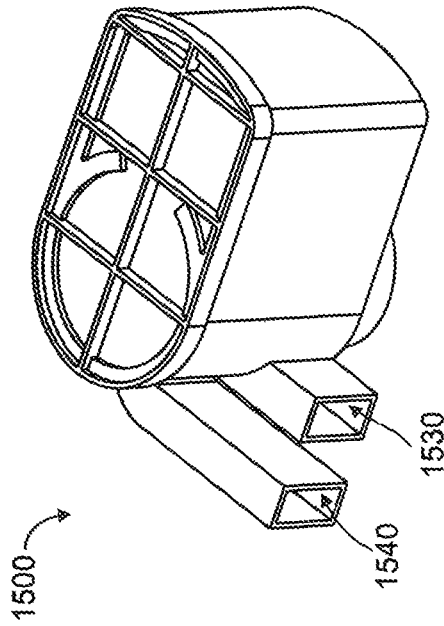

FIG. 12A

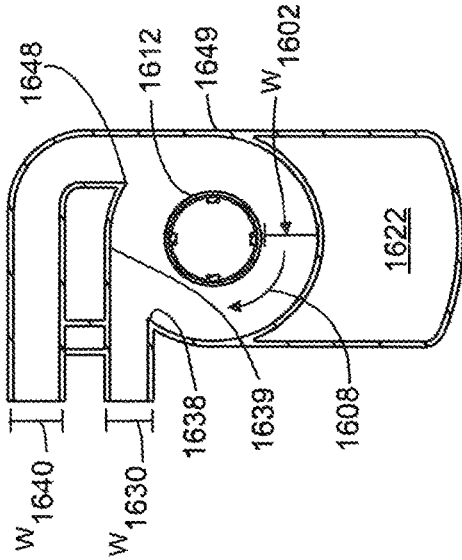

FIG. 13D

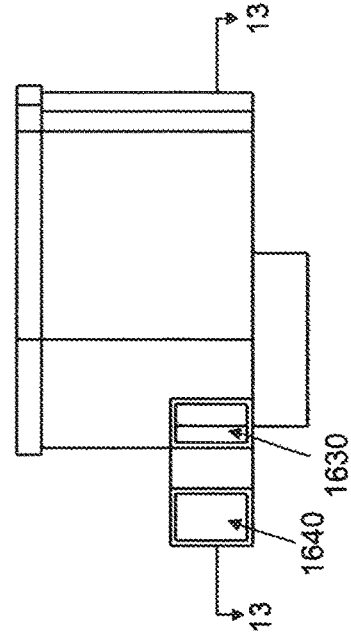

FIG. 13B

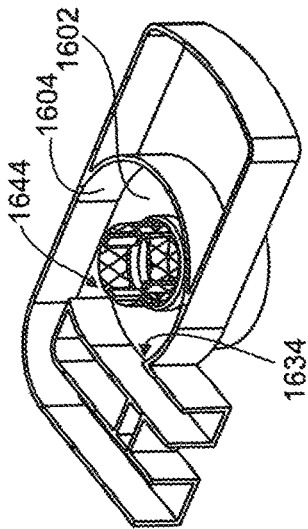

FIG. 13C

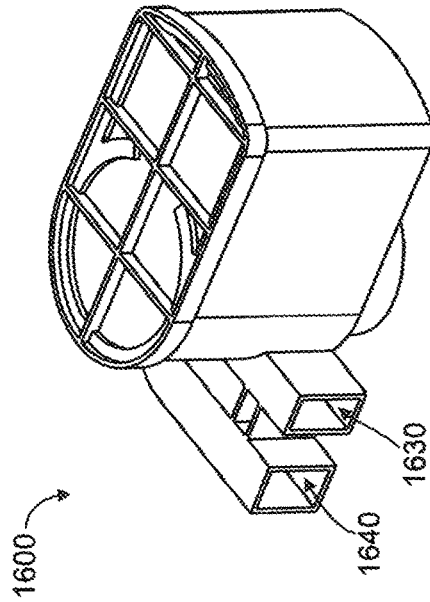

FIG. 13A

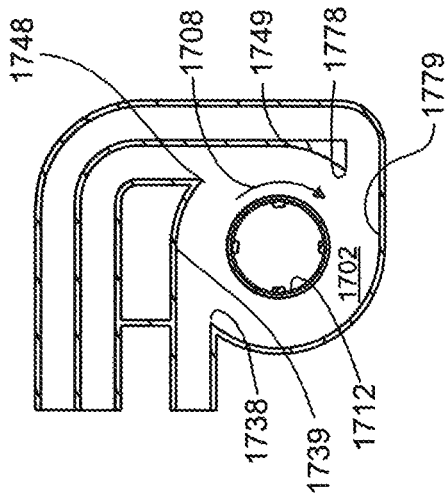

FIG. 14D

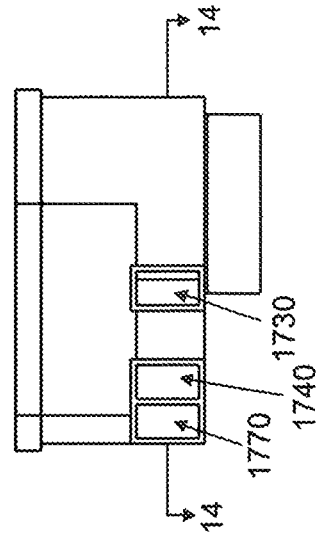

FIG. 14B

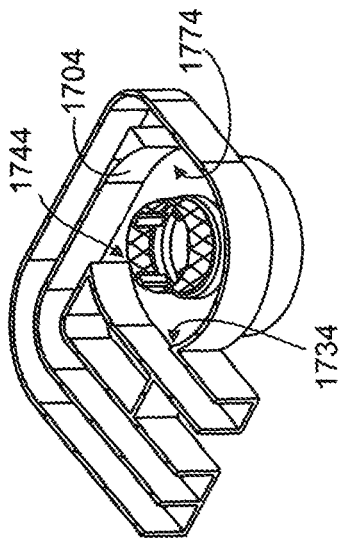

FIG. 14C

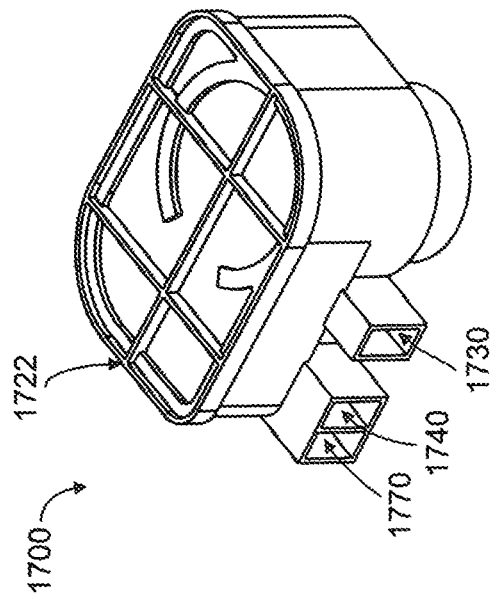

FIG. 14A



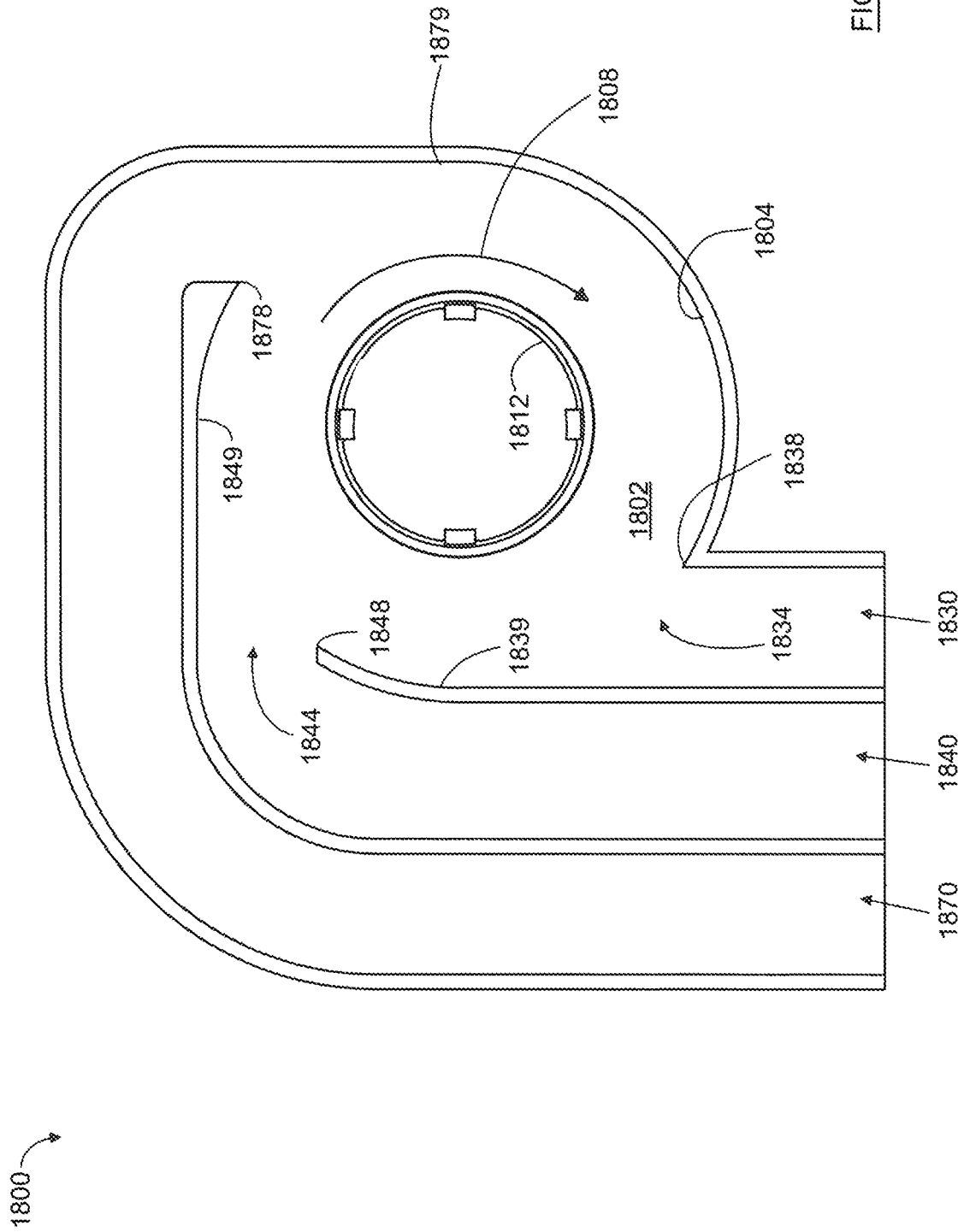

FIG. 15

1

## SURFACE CLEANING APPARATUS

## FIELD

This disclosure relates generally to surface cleaning apparatus such as hand vacuum cleaners, upright vacuum cleaners, stick vacuum cleaners or canister vacuum cleaners, and in particular surface cleaning apparatus with multi-inlet cyclone chambers.

## INTRODUCTION

The following is not an admission that anything discussed below is part of the prior art or part of the common general knowledge of a person skilled in the art.

Various types of surface cleaning apparatus are known, including upright surface cleaning apparatus, canister surface cleaning apparatus, stick surface cleaning apparatus, central vacuum systems, and hand carryable surface cleaning apparatus such as hand vacuums. Further, various designs for cyclonic surface cleaning apparatus are known in the art, including cyclonic hand vacuum cleaners.

Cyclones may have an axial inlet or a tangential inlet. Further a cyclone may have multiple inlets which are fed by a single chamber. See for example US2018/0177363.

## SUMMARY

The following introduction is provided to introduce the reader to the more detailed discussion to follow. The introduction is not intended to limit or define any claimed or as yet unclaimed invention. One or more inventions may reside in any combination or sub-combination of the elements or process steps disclosed in any part of this document including its claims and figures.

In surface cleaning apparatuses, reduced size can provide improved maneuverability and ease of use, particularly for hand vacuum cleaners. However, surface cleaning apparatuses are constrained by the number of components necessary to provide the cleaning operation, such as a suction motor, a cyclone chamber, and a dirt collection area. Reducing the size required for these components without negatively impacting the operability of a surface cleaning apparatus is thus highly desirable.

In accordance with one aspect of this disclosure, which may be used alone or in combination with any other aspect, a surface cleaning apparatus is provided with a cyclone chamber that operates as an air treatment member. Dirty air enters the cyclone chamber, and dirt and debris is separated from the air as it flows through the cyclone chamber.

When dirty air is introduced into a cyclone chamber, the air travels in a swirling pattern from the inlet end of the cyclone to the opposite end. Air enters the cyclone chamber as a band that substantially maintains its form as it swirls around the cyclone chamber. To ensure that dirt and debris is sufficiently separated from the swirling air, each band of air entering the cyclone chamber should complete a minimum number of revolutions around the cyclone chamber, e.g. 3 or 4 revolutions. As a result, the height of the cyclone chamber is dictated by the number of revolutions required and the height of the air bands entering the cyclone chamber.

The height of air bands entering the cyclone chamber is dictated by the height of the inlets to the cyclone chamber. The taller the cyclone inlets, the taller the cyclone chamber must be to provide the desired number of revolutions. For example, if a cyclone air inlet were 1 inch tall, the cyclone chamber would have to be 4-4.5 inches to allow 4 complete

2

rotations of the air band entering the cyclone chamber. If the inlet were 2 inches tall, the cyclone chamber would have to be 8-9 inches tall to allow 4 complete revolutions.

The height of the cyclone inlet is also dictated by the volume of air drawn into the surface cleaning apparatus. To reduce backpressure, the cyclone inlet should be large enough to accommodate the volume of air drawn into the surface cleaning apparatus. Thus, the cross-sectional area of the cyclone inlet must be increased if a greater volume of air is to be drawn into the surface cleaning apparatus. This often requires taller cyclone inlets, resulting in a corresponding increase in the height of the cyclone chamber.

In accordance with one aspect of this disclosure, which may be used alone or in combination with any other aspect, a surface cleaning apparatus may be provided with multiple airflow passages leading to the cyclone chamber. Each airflow passage may terminate at one or more ports into the cyclone chamber. Therefore, if an airflow passage terminates at a single port in the sidewall of a cyclone chamber, then each airflow passage may provide a separate air inlet to the cyclone chamber. Each cyclone inlet can be a substantially tangential air inlet into the cyclone chamber. By providing multiple separate airflow passages through which the dirty air can enter the cyclone chamber, the height of the cyclone inlets may be reduced without reducing the volume of air that can be drawn into the surface cleaning apparatus and the separation efficiency of the cyclone may be improved.

In accordance with this broad aspect, there is provided a surface cleaning apparatus comprising:

(a) an air flow path extending from a dirty air inlet to a clean air outlet with a suction motor positioned in the air flow path; and,

(b) a cyclone positioned in the air flow path, the cyclone having a cyclone chamber, a cyclone chamber sidewall, a first airflow passage having an inlet end and a downstream outlet end wherein the downstream outlet end comprises a first tangential air inlet, a second airflow passage having an inlet end and a downstream outlet end wherein the downstream outlet end comprises a second tangential air inlet, a cyclone air outlet and a longitudinal cyclone axis about which the air rotates in the cyclone chamber in a direction of rotation of air in the cyclone chamber,

wherein the first tangential air inlet has an upstream edge that is upstream from a downstream edge of the first tangential air inlet in the direction of rotation of air in the cyclone chamber and the second tangential air inlet has an upstream edge that is upstream from a downstream edge of the second tangential air inlet in the direction of rotation of air in the cyclone chamber, and wherein the first and second airflow passages are isolated from each other, and

wherein the second tangential air inlet is positioned around a perimeter of the cyclone chamber sidewall downstream from the first tangential air inlet in the direction of rotation of air in the cyclone chamber.

In any embodiment, a plane transverse to the cyclone axis may extend through the first and second tangential air inlets.

In any embodiment, a portion of each of the first and second airflow passages may extend generally parallel to the cyclone axis and the portions can be adjacent each other.

In any embodiment, a portion of each of the first and second airflow passages may extend generally parallel to the cyclone axis and the portions may abut each other.

In any embodiment, the first and second airflow passages may be positioned exterior to the cyclone chamber sidewall.

3

In any embodiment, the inlet end of the first airflow passage and the inlet end of the second airflow passage may each be in fluid communication with a single upstream air flow conduit.

In any embodiment, the surface cleaning apparatus may be a hand vacuum cleaner and each of the first and second airflow passages may extend from the dirty air inlet.

In any embodiment, the surface cleaning apparatus may be a hand vacuum cleaner and each of the first and second airflow passages may extend from an inlet end of the dirty air inlet.

In any embodiment, the upstream edge of the second tangential air inlet may be adjacent the downstream edge of the first tangential air inlet.

In any embodiment, a portion of the cyclone chamber sidewall may be positioned between the upstream edge of the second tangential air inlet and the downstream edge of the first tangential air inlet.

In any embodiment, a downstream portion of the second airflow passage may be spaced apart from a downstream portion of the first airflow passage.

In any embodiment, the downstream portion of the second airflow passage may be generally linear.

In any embodiment, a downstream portion of the first airflow passage may be generally linear.

In accordance with another aspect of this disclosure, which may be used alone or in combination with any other aspect, it may be desirable for the cyclone chamber to have multiple airflow passages leading to multiple inlet ports in the sidewall of a cyclone chamber while providing a common airflow passage for the dirty air entering the surface cleaning apparatus. This may simplify the design of the inlet conduit, and ensure that the entire volume of the inlet conduit is available to draw in dirty air.

In accordance with this broad aspect, there is provided a surface cleaning apparatus comprising:

(a) an air flow path extending from a dirty air inlet to a clean air outlet with a suction motor positioned in the air flow path; and,

(b) a cyclone positioned in the air flow path, the cyclone having a cyclone chamber, a cyclone chamber sidewall, a first airflow passage having an inlet end and a downstream outlet end wherein the downstream outlet end comprises a first tangential air inlet, a second airflow passage having an inlet end and a downstream outlet end wherein the downstream outlet end comprises a second tangential air inlet, a cyclone air outlet and a longitudinal cyclone axis about which the air rotates in the cyclone chamber in a direction of rotation of air in the cyclone chamber,

wherein the air flow path comprises a common airflow passage upstream of the first and second airflow passages and an axis of the common airflow passage intersects the cyclone chamber,

wherein the second tangential air inlet is positioned around a perimeter of the cyclone chamber sidewall downstream from the first tangential air inlet in the direction of rotation of air in the cyclone chamber, and wherein at least a portion of the first airflow passage is positioned upstream from a location at which the common airflow passage axis intersects the cyclone chamber.

In any embodiment, the surface cleaning apparatus may include a divider located adjacent the cyclone at a downstream end of the common airflow passage.

4

In any embodiment, the divider may include a convex member that extends towards the downstream end of the common airflow passage.

In any embodiment, the surface cleaning apparatus may include a convex member that extends towards the downstream end of the common airflow passage.

In any embodiment, the convex member may have a first portion that comprises a wall at an inlet end to the first airflow passage and a second portion that comprises a wall at an inlet end to the second airflow passage.

In any embodiment, the divider may have a first portion that comprises a wall at an inlet end to the first airflow passage and a second portion that comprises a wall at an inlet end to the second airflow passage.

In any embodiment, the second airflow passage may extend generally linearly from the convex member to the second tangential air inlet and at least a portion of the first airflow passage may extend in a counter rotational direction from the convex member to the first tangential air inlet.

In any embodiment, the second airflow passage may extend generally linearly from the divider to the second tangential air inlet and at least a portion of the first airflow passage may extend in a counter rotational direction from the divider to the first tangential air inlet.

In any embodiment, at least a portion of the first airflow passage may extend in a counter rotational direction.

In any embodiment, the common airflow passage may extend downstream from the dirty air inlet.

In any embodiment, the common airflow passage may extend generally linearly to the first and second airflow passages.

In accordance with this broad aspect, there is also provided a surface cleaning apparatus comprising:

(a) an air flow path extending from a dirty air inlet to a clean air outlet with a suction motor positioned in the air flow path; and,

(b) a cyclone positioned in the air flow path, the cyclone having a cyclone chamber, a cyclone chamber sidewall, a first airflow passage having an inlet end and a downstream outlet end wherein the downstream outlet end comprises a first tangential air inlet, a second airflow passage having an inlet end and a downstream outlet end wherein the downstream outlet end comprises a second tangential air inlet, a cyclone air outlet and a longitudinal cyclone axis about which the air rotates in the cyclone chamber in a direction of rotation of air in the cyclone chamber,

wherein the air flow path comprises a common airflow passage upstream of the first and second airflow passages,

wherein the second tangential air inlet is positioned around a perimeter of the cyclone chamber sidewall downstream from the first tangential air inlet in the direction of rotation of air in the cyclone chamber, and wherein at least a portion of the first airflow passage extends in a counter rotational direction.

It will be appreciated that this latter surface cleaning apparatus may use any one or more of the features previously set out.

It will be appreciated by a person skilled in the art that an apparatus or method disclosed herein may embody any one or more of the features contained herein and that the features may be used in any particular combination or sub-combination.

These and other aspects and features of various embodiments will be described in greater detail below.

#### BRIEF DESCRIPTION OF THE DRAWINGS

For a better understanding of the described embodiments and to show more clearly how they may be carried into effect, reference will now be made, by way of example, to the accompanying drawings in which:

FIG. 1 is a top front perspective view of a hand vacuum cleaner in accordance with an embodiment;

FIG. 2 is a sectional view of the hand vacuum cleaner of FIG. 1, taken along line 2-2 in FIG. 1 with a first example airflow passage;

FIG. 3 is a sectional view of the hand vacuum cleaner of FIG. 1, taken along line 3-3 in FIG. 1 with the first example airflow passage;

FIG. 4 is a perspective sectional view of the hand vacuum cleaner of FIG. 1, taken along line 3-3 in FIG. 1 with the first example airflow passage;

FIG. 5 is a sectional view of the hand vacuum cleaner of FIG. 1, taken along line 2-2 in FIG. 1 with a second example airflow passage;

FIG. 6 is a perspective sectional view of the hand vacuum cleaner of FIG. 1, taken along line 3-3 in FIG. 1 with the second example airflow passage;

FIG. 7 is a sectional view of the hand vacuum cleaner of FIG. 1, taken along line 2-2 in FIG. 1 with the second example airflow passage;

FIG. 8 is a sectional view of the hand vacuum cleaner of FIG. 1, taken along line 3-3 in FIG. 1 with the second example airflow passage;

FIG. 9A is a top perspective view of an example cyclone and airflow passage for a vacuum cleaner in accordance with an embodiment;

FIG. 9B is a front view of the example cyclone and airflow passage of FIG. 9A;

FIG. 9C is a perspective sectional view of the example cyclone and airflow passage of FIG. 9A, taken along line 9-9 in FIG. 9B;

FIG. 9D is a sectional view of the example cyclone and airflow passage of FIG. 9A, taken along line 9-9 in FIG. 9B;

FIG. 10A is a top perspective view of an example cyclone and airflow passage for a vacuum cleaner in accordance with an embodiment;

FIG. 10B is a front view of the example cyclone and airflow passage of FIG. 10A;

FIG. 10C is a perspective sectional view of the example cyclone and airflow passage of FIG. 10A, taken along line 10-10 in FIG. 10B;

FIG. 10D is a sectional view of the example cyclone and airflow passage of FIG. 10A, taken along line 10-10 in FIG. 10B;

FIG. 11A is a top perspective view of an example cyclone and airflow passage for a vacuum cleaner in accordance with an embodiment;

FIG. 11B is a front view of the example cyclone and airflow passage of FIG. 11A;

FIG. 11C is a perspective sectional view of the example cyclone and airflow passage of FIG. 11A, taken along line 11-11 in FIG. 11B;

FIG. 11D is a sectional view of the example cyclone and airflow passage of FIG. 11A, taken along line 11-11 in FIG. 11B;

FIG. 12A is a top perspective view of an example cyclone and airflow passage for a vacuum cleaner in accordance with an embodiment;

FIG. 12B is a front view of the example cyclone and airflow passage of FIG. 12A;

FIG. 12C is a perspective sectional view of the example cyclone and airflow passage of FIG. 12A, taken along line 12-12 in FIG. 12B;

FIG. 12D is a sectional view of the example cyclone and airflow passage of FIG. 12A, taken along line 12-12 in FIG. 12B;

FIG. 13A is a top perspective view of an example cyclone and airflow passage for a vacuum cleaner in accordance with an embodiment;

FIG. 13B is a front view of the example cyclone and airflow passage of FIG. 13A;

FIG. 13C is a perspective sectional view of the example cyclone and airflow passage of FIG. 13A, taken along line 13-13 in FIG. 13B;

FIG. 13D is a sectional view of the example cyclone and airflow passage of FIG. 13A, taken along line 13-13 in FIG. 13B;

FIG. 14A is a top perspective view of an example cyclone and airflow passage for a vacuum cleaner in accordance with an embodiment;

FIG. 14B is a front view of the example cyclone and airflow passage of FIG. 14A;

FIG. 14C is a perspective sectional view of the example cyclone and airflow passage of FIG. 14A, taken along line 14-14 in FIG. 14B;

FIG. 14D is a sectional view of the example cyclone and airflow passage of FIG. 14A, taken along line 14-14 in FIG. 14B; and,

FIG. 15 is a top section view of another example cyclone and airflow passage for a vacuum cleaner in accordance with an embodiment.

The drawings included herewith are for illustrating various examples of articles, methods, and apparatuses of the teaching of the present specification and are not intended to limit the scope of what is taught in any way.

#### DESCRIPTION OF EXAMPLE EMBODIMENTS

Various apparatuses, methods and compositions are described below to provide an example of an embodiment of each claimed invention. No embodiment described below limits any claimed invention and any claimed invention may cover apparatuses and methods that differ from those described below. The claimed inventions are not limited to apparatuses, methods and compositions having all of the features of any one apparatus, method or composition described below or to features common to multiple or all of the apparatuses, methods or compositions described below. It is possible that an apparatus, method or composition described below is not an embodiment of any claimed invention. Any invention disclosed in an apparatus, method or composition described below that is not claimed in this document may be the subject matter of another protective instrument, for example, a continuing patent application, and the applicant(s), inventor(s) and/or owner(s) do not intend to abandon, disclaim, or dedicate to the public any such invention by its disclosure in this document.

The terms “an embodiment,” “embodiment,” “embodiments,” “the embodiment,” “the embodiments,” “one or more embodiments,” “some embodiments,” and “one embodiment” mean “one or more (but not all) embodiments of the present invention(s),” unless expressly specified otherwise.

The terms “including,” “comprising” and variations thereof mean “including but not limited to,” unless expressly

specified otherwise. A listing of items does not imply that any or all of the items are mutually exclusive, unless expressly specified otherwise. The terms “a,” “an” and “the” mean “one or more,” unless expressly specified otherwise.

As used herein and in the claims, two or more parts are said to be “coupled”, “connected”, “attached”, or “fastened” where the parts are joined or operate together either directly or indirectly (i.e., through one or more intermediate parts), so long as a link occurs. As used herein and in the claims, two or more parts are said to be “directly coupled”, “directly connected”, “directly attached”, or “directly fastened” where the parts are connected in physical contact with each other. None of the terms “coupled”, “connected”, “attached”, and “fastened” distinguish the manner in which two or more parts are joined together.

Furthermore, it will be appreciated that for simplicity and clarity of illustration, where considered appropriate, reference numerals may be repeated among the figures to indicate corresponding or analogous elements. In addition, numerous specific details are set forth in order to provide a thorough understanding of the example embodiments described herein. However, it will be understood by those of ordinary skill in the art that the example embodiments described herein may be practiced without these specific details. In other instances, well-known methods, procedures, and components have not been described in detail so as not to obscure the example embodiments described herein. Also, the description is not to be considered as limiting the scope of the example embodiments described herein.

Referring to FIGS. 1 to 4, an exemplary embodiment of a surface cleaning apparatus is shown generally as 1000. In the illustrated embodiment, the surface cleaning apparatus is a hand vacuum cleaner, which may also be referred to also as a “handvac” or “hand-held vacuum cleaner”. As used herein, a hand vacuum cleaner is a vacuum cleaner that can be operated to clean a surface generally one-handedly. That is, the entire weight of the vacuum may be held by the same one hand used to direct a dirty air inlet of the vacuum cleaner with respect to a surface to be cleaned. For example, the handle and a clean air inlet may be rigidly coupled to each other (directly or indirectly) so as to move as one while maintaining a constant orientation relative to each other. This is to be contrasted with canister and upright vacuum cleaners, whose weight is typically supported by a surface (e.g. a floor) during use. It will be appreciated that surface cleaning apparatus 1000 may alternately be any surface cleaning apparatus, such as an upright surface cleaning apparatus, a stick vac, a canister surface cleaning apparatus, an extractor or the like. It will also be appreciated that the surface cleaning apparatus may use any configuration of the operating components and the airflow paths exemplified herein.

As exemplified in FIGS. 1 to 4, surface cleaning apparatus 1000 includes a main body 1010 having a housing 1011 and a handle 1020, an air treatment member 1100 connected to the main body 1010, a dirty air inlet 1030, a clean air outlet 1040, and an air flow path extending between the dirty air inlet 1030 and the clean air outlet 1040.

Surface cleaning apparatus 1000 has a front end 1002, a rear end 1004, an upper end or top 1006, and a lower end or bottom 1008. In the embodiment shown, dirty air inlet 1030 is at an upper portion of the front end 1002 and clean air outlet 1040 is at rearward portion of the lower end 1008. It will be appreciated that the dirty air inlet 1030 and the clean air outlet 1040 may be provided in different locations.

A suction motor 1050 (see e.g. FIG. 2) is provided to generate vacuum suction through the air flow path, and is

positioned within a motor housing. In the illustrated embodiment, the suction motor 1050 is positioned downstream from the air treatment member 1100, although it may be positioned at any location in the surface cleaning apparatus such as upstream of the air treatment member (e.g., a dirty air motor) in alternative embodiments.

Air treatment member 1100 is configured to remove particles of dirt and other debris from the air flow and/or otherwise treat the air flow. In the illustrated example, air treatment member 1100 includes a cyclone assembly having a single cyclonic cleaning stage with a single cyclone chamber 1102 and a dirt collection region 1122 external to the cyclone chamber. The dirt collection chamber 1122 is positioned exterior to the cyclone chamber 1102 and is in communication with the dirt outlet 1120 to receive dirt and debris dis-entrained from a dirty air flow by the cyclone chamber 1110. The cyclone chamber 1102 and dirt collection region 1122 may be of any configuration suitable for separating dirt from an air stream and collecting the separated dirt, respectively.

In alternative embodiments, the cyclone assembly may include two or more cyclonic cleaning stages arranged in series with each other.

Each cyclonic cleaning stage may include one or more cyclone chambers (arranged in parallel or series with each other) and one or more dirt collection chambers, of any suitable configuration. The dirt collection chamber or chambers may be external to the cyclone chambers, or may be internal the cyclone chamber and configured as a dirt collection area or region within the cyclone chamber. Alternatively, the surface cleaning apparatus may also incorporate additional air treatment members, such as a bag, a porous physical filter media (such as foam or felt), or other air treating means.

The surface cleaning apparatus 1000 may include a pre-motor filter housing provided in the air flow path downstream of the air treatment member 1100 and upstream of the suction motor 1050. The pre-motor filter housing may be of any suitable construction, including any of those exemplified herein. A pre-motor filter 1320 is positioned within the pre-motor filter housing. Pre-motor filter 1320 may be formed from any suitable physical, porous filter media and have any suitable shape, including the examples disclosed herein with respect to a removable pre-motor filter assembly. For example, the pre-motor filter may be one or more of a foam filter, felt filter, HEPA filter, other physical filter media, electrostatic filter, and the like.

Optionally, hand vacuum cleaner 1000 may also include a post-motor filter provided in the air flow path downstream of the suction motor 1050 and upstream of the clean air outlet 1040. Post-motor filter may be formed from any suitable physical, porous filter media and have any suitable shape, including the examples disclosed herein. In alternative embodiments, the post-motor filter may be any suitable type of filter such as one or more of a foam filter, felt filter, HEPA filter, other physical filter media, electrostatic filter, and the like.

In the illustrated embodiment, the dirty air inlet 1030 of the hand vacuum cleaner 1000 is the inlet end 1032 of an inlet conduit 1036. Optionally, inlet end 1032 of the conduit 1036 can be used as a nozzle to directly clean a surface. The air inlet conduit 1036 is, in this example, a generally linear hollow member that extends along an inlet conduit axis 1035 that is oriented in a longitudinal forward/backward direction and is generally horizontal when hand vacuum cleaner 1000 is oriented with the upper end 1006 above the lower end 1008. Alternatively, or in addition to functioning as a nozzle,

inlet conduit **1036** may be connected or directly connected to the downstream end of any suitable accessory tool such as a rigid air flow conduit (e.g., an above floor cleaning wand), a crevice tool, a mini brush, and the like. As shown, dirty air inlet **1030** is positioned forward of the air treatment member **1100**, although this need not be the case. As exemplified, the dirty air inlet **1030** is positioned so that the inlet conduit axis **1035** intersects the cyclone chamber **1102**. Optionally, the dirty air inlet **1030** may be provided at an alternate location, such as above the cyclone chamber **1102**.

The hand vacuum cleaner also includes a clean air outlet **1040** at the outlet end of the airflow path. The clean air outlet may be located at any position on the surface cleaning apparatus **1000**. As exemplified, air may exit the hand vacuum cleaner **1000** via a grill located in a lower portion of the main body **1010** (e.g., via an air outlet provided in the rear end of the main body **1010** or a sidewall adjacent the rear end as shown in FIG. 1). Alternately, air may exit through an upper portion of the main body **1010** or the rear end of the main body **1010**.

An optional accessory power coupler **1061** may be provided, e.g., adjacent to the inlet conduit **1036**. Accessory power coupler **1061** includes a set of electrical connectors that can inter-engage with compatible electrical connectors on an accessory tool in order to provide an electrical connection between e.g. a power source of the hand vacuum and a motor or other electrical device of an accessory tool (e.g. a powered brush roller, a light source, and the like). While the illustrated accessory power coupler **1061** is a male connector (i.e. projecting outwardly from the main body **1010** of the hand vacuum cleaner **1000**), in alternative embodiments it may be a female connector (i.e. recessed inwardly) or any other shape suitable for cooperatively engaging with corresponding connectors on an accessory tool or other attachment. As exemplified, the accessory power coupler **1061** may be positioned laterally to one side of the inlet conduit **1036**. In other examples, the accessory power coupler **1061** may be located above or below the inlet conduit **1036**.

As exemplified, power may be supplied to the suction motor **1050** and other electrical components of the hand vacuum cleaner from an onboard energy storage member which may include, for example, one or more batteries or other energy storage device. In the illustrated embodiment, the hand vacuum cleaner **1000** includes a removable battery pack **1080** provided below the handle **1020**. The battery pack **1080** can include one or more energy storage members, such as batteries. In alternative embodiments, a battery pack may not be provided and power may be supplied to the hand vacuum cleaner by an electrical cord connected to the hand vacuum cleaner (not shown) that can be connected to a standard wall electrical outlet.

As exemplified, a power switch **1060** may be provided to selectively control the operation of the suction motor (e.g. either on/off or variable power levels or both), for example by establishing a power connection between the batteries and the suction motor. The power switch may be provided in any suitable configuration and location, including a button, rotary switch, sliding switch, trigger-type actuator and the like. As illustrated in FIG. 2, power switch **1060** is in the form of a switch located toward the upper portion of the rear end **1004** of the hand vacuum cleaner, above the handle **1020**. In this position, a user may be able to access the button **1060** while holding the hand vacuum via the hand grip, e.g. with the thumb of the hand holding the handle, and/or with a digit of their other hand.

The power switch **1060** or an alternate controller may also be configured to control other aspects of the hand vacuum (brush motor on/off, etc.). Optionally, instead of being provided at an upper end of the handle, the power switch may be provided on the main body (such as on the motor housing or other suitable location).

An optional information display device may be provided to display one or more visual indications to a user. For example, the display device may provide a visual indication of: when suction motor is on; the current power level of the suction motor (if applicable); the current battery charge level (if applicable); an estimated time until the battery charge will be depleted (if applicable), and/or similar information. The display device may include one or more light sources (e.g. light emitting diodes (LEDs)), display screens (e.g. a liquid crystal, an LED screen, an organic light emitting diode (OLED) screen, and the like). The screen, and associated electronics, may be used to display status information of one or more electrical components of the hand vacuum cleaner.

As exemplified in the embodiments of FIGS. 2-8, hand vacuum cleaners **1000** and **1000A** may include a single cyclonic cleaning stage with a cyclone chamber **1102** that has multiple cyclone air inlet passages in fluid communication with (downstream of) the inlet conduit **1036**, a cyclone air outlet **1110**, and a dirt outlet **1120** that is in communication with a dirt collection chamber **1122**.

As described above, the surface cleaning apparatus **1000** (and surface cleaning apparatus **1000A**) includes an air flow path extending from the dirty air inlet **1030** to the clean air outlet **1040**. The suction motor **1050** and cyclone **1100** are positioned in the air flow path. Air entering the dirt air inlet **1030** is directed to the cyclone chamber **1102** via multiple separate airflow passages.

The cyclone air inlets of cyclone chamber **1102** are provided by the downstream ends of separate airflow passages that are located downstream of the inlet conduit **1036**. In the example shown, hand vacuum cleaners **1000** and **1000A** include a first airflow passage **1130** and a second airflow passage **1140** having an upstream end that is fluidly connected to a downstream end of the inlet conduit **1036** and a downstream end that is fluidly connected to cyclone chamber **1102**.

As exemplified, the cyclone **1100** of the hand vacuum cleaners **1000** and **1000A** may optionally be a single cyclonic cleaning stage with bidirectional air flow (i.e. where the cyclone air inlet and cyclone air outlet are at the same end of the cyclone chamber). Alternatively, a 'uniflow' cyclone chamber (i.e. where the cyclone air inlet and cyclone air outlet are at opposite ends of the cyclone chamber) may be used as the air treatment member **1100**. Optionally, the cyclone may be an inverted cyclone.

The cyclone chamber **1102** may be oriented in any direction. For example, when surface cleaning apparatus **1000** or **1000A** is oriented with the upper end **1106** above the lower end **1108**, e.g. positioned generally parallel to a horizontal surface, a central axis or axis of rotation **1106** of the cyclone chamber **1102** may be oriented vertically, as exemplified in FIG. 2. Air in the cyclone chamber **1102** rotates around the central axis **1106** in a defined direction of rotation **1108**, shown as clockwise in the illustrated example. In alternative embodiments, the cyclone chamber may be oriented horizontally, or at any angle between horizontal and vertical.

As shown in FIG. 2, the cyclone air outlet **1160** is provided in the upper end wall of the cyclone chamber **1102** and a vertically extending vortex finder conduit **1112**

extends from the upper end wall and is aligned with the cyclone air outlet **1160**. Optionally, a mesh screen **1114** may be positioned over some or all of the inlet apertures of the vortex finder conduit **1112** to help inhibit lint, hair, and other such debris from entering the vortex finder conduit **1112**.

As shown, the cyclone chamber **1102** includes a cyclone chamber sidewall **1104** that extends generally parallel to the cyclone axis **1106**. The cyclone chamber sidewall **1104** extends between an upper wall of the cyclone chamber **1102** (adjacent the cyclone outlet **1110**) and the dirt outlet **1120**. The cyclone air inlet passages may terminate at inlet ports formed in the sidewall **1104**.

As exemplified in FIG. 3, the air flow path includes a common airflow passage **1150** positioned upstream of the first airflow passage **1130** and the second airflow passage **1140**. Air entering the dirty air inlet **1030** passes through the common airflow passage **1150**, then separates into the first airflow passage **1130** and the second airflow passage **1140** before entering the cyclone chamber **1102**. As shown in the example of FIG. 3, the common air flow passage **1150** extends from the dirty air inlet **1030** to a divider **1160** separating the first airflow passage **1130** and the second airflow passage **1140** and may thus also be considered the inlet passage **1036**.

Alternatively, a common air flow passage **1150** may be omitted. In some such embodiments, separate air flow passages may extend from the dirty air inlet **1030** to the cyclone chamber **1102**. See for example FIGS. 9A-D.

The common air flow passage **1150** may extend towards the cyclone chamber **1102**. As shown in FIG. 3, the common airflow passage **1150** may have a central axis **1151** that intersects the cyclone chamber **1102**. In some examples, the common airflow passage **1150** may extend generally linearly to the first and second airflow passages, i.e. without any bends or turns in the common airflow passage **1150**. This may reduce backpressure and airflow losses through the common airflow passage.

Alternatively, the common air flow passage **1150** may extend in an alternative direction, where its central axis does not intersect the cyclone chamber. For instance, the common air flow passage may extend at an angle to the separate air flow passages leading to the cyclone chamber. In such cases, the angle between the common air flow passage and the separated air flow passages may be up to 90°. In this arrangement, for instance where the cyclone axis extends horizontally, air travelling through the hand vacuum cleaner may travel generally rearwardly along a common airflow passage (i.e. parallel to the conduit axis **1035**) and then enter a tangential air inlet which essentially changes the direction of the air to travel generally downwardly through the cyclone air inlet (i.e. generally orthogonal to the cyclone axis).

As exemplified in FIG. 3, in hand vacuum cleaner **1000**, the divider **1160** is positioned adjacent to the cyclone **1100** at the downstream end of the common airflow passage **1150**. Hand vacuum cleaner **1000A** (FIG. 8) is generally similar to hand vacuum cleaner **1000**, except that in hand vacuum cleaner **1000** divider **1160** is provided by a convex member **1170** rather than divider member **1162**, which has a generally straight transverse face that faces the inlet passages **1130** and **1140**. In both examples, divider **1160** and divider **1170** divide the air from the common airflow passage **1150** into the first airflow passage **1130** and second airflow passage **1140**.

Optionally, the divider **1160** may also define a portion of the cyclone chamber sidewall **1104**. This may reduce the space required for the divider **1160**, by partially integrating it into the cyclone unit **1100**.

The divider **1160** may include separate wall portions for the first airflow passage and the second airflow passage. For instance, the divider **1160** may include a first wall portion **1172** at the upstream inlet end **1132** of the first airflow passage **1130** and a second wall portion **1174** at the upstream inlet end **1142** of the second airflow passage **1140**. The first wall portion **1172** may have a different shape from the second wall portion **1174**.

In some embodiments, at least a portion of the first airflow passage **1130** may extend in a counter rotational direction as it extends from the divider **1160** to the second tangential air inlet **1134** (see e.g. FIG. 3).

The divider **1160** may define a junction at the downstream end of the common airflow passage **1150**. For example, the junction may be a t-shaped junction formed by a divider member **1162** having a substantially straight upstream wall (see e.g. FIG. 6). This may encourage the air to separate between the first air passage **1130** and second air passage **1140**, optionally evenly, based on the pressure in each airflow passage.

Alternatively, the divider **1160** may be a convex member **1170** (see e.g. FIG. 3). As shown, the convex member **1170** has an outer surface that extends towards the downstream end of the common airflow passage **1150**. Shaping the divider **1160** as a convex member **1170** may help reduce backpressure by redirecting the air flow from the common airflow passage **1150** gradually and avoiding sharp turns or bends in the air flow pathway, which could cause eddy currents.

Alternatively, the divider **1160** may be any suitable member positioned to separate the airflow from the common airflow passage **1150** into multiple downstream airflow passages leading into the cyclone chamber **1102**. For example, instead of being convex, walls **1172** and **1174** could meet at an apex point or a generally rounded juncture.

The first airflow passage **1130** extends from an upstream inlet end **1132**, positioned at the downstream end of the common airflow passage **1150**, to a downstream outlet end **1134**. The downstream outlet end **1134**, which may be a port or opening in the sidewall of the cyclone, defines one of the cyclone air inlets and may provide a tangential air inlet. Similarly, the second airflow passage **1140** extends from an upstream inlet end **1142** to a downstream outlet end **1144**, which may be a port or opening in the sidewall of the cyclone, with the downstream outlet end **1144** defining another cyclone air inlet, which may also be a tangential air inlet.

The second airflow passage **1140** may extend more linearly from the divider **1160** to the second tangential air inlet **1144** than the first airflow passage. Using a more linear path for the second airflow passage may reduce the backpressure on the air in the second airflow passage **1140** by reducing the number of bends in the air flow path. As shown in FIG. 3, the second airflow passage curves slightly in the direction or rotation of air in the cyclone as opposed to a more linear path as exemplified in FIG. 8. It will be appreciated that the first and second air flow paths may have different amounts of curvature.

As shown in the example of FIG. 3, at least a portion **1178** of the first airflow passage **1130** may extend in a counter rotational direction. That is, the first airflow passage **1130** may include a portion that extends in a direction opposite to the direction of rotation **1108** of air in the cyclone **1100**. As

shown, air in the cyclone **1100** rotates in a clockwise direction **1108**. Accordingly, the first airflow passage **1130** includes a portion **1178** that extends in a counterclockwise direction.

As exemplified in FIG. 3, after portion **1178** of the first air flow path curves in a direction counter to the rotational direction in the cyclone as the passage travels along wall **1172**, the passage then curves in the rotational direction of air in the cyclone so as to provide a tangential air inlet. In contrast, as exemplified in FIG. 8, the front wall of divider **1162**, which is straight, extends towards a lateral side of the cyclone such that, downstream of the front wall, the passage curves in the rotational direction of air in the cyclone so as to provide a tangential air inlet. It will be appreciated that if the front wall had a shorter length, then the upstream end of the first air flow [passage may direct the air in a counter rotational direction.

The volume of air drawn into the cyclone chamber **1102** is limited by the size of the cyclone inlets. By providing two inlets **1134** and **1144**, the height of each inlet may be reduced by half as compared to a single inlet cyclone (having the same width as each of the inlets **1134** and **1144**), while permitting the same volume of air to be drawn through (i.e. without reducing the total cross-sectional area of the cyclone inlets).

In the example shown, each of the cyclone air inlets provided by the first and second airflow passages have the same inlet height, indicated as  $h_i$ . Alternatively, the height of the cyclone inlets may be different, which may encourage more air to flow towards the taller inlet (assuming the inlets have the same width).

The height  $h_c$  of the cyclone chamber **1102** may be defined as a multiple of the height  $h_i$  of each inlet. The height of the cyclone chamber **1102** may be selected based on the number of revolutions through the cyclone chamber **1102** that are desired for sufficient separation of dirt and debris. Height  $h_c$  may be about 2-6, 3-5, or 3-4 times the height  $h_i$ . For instance, the height  $h_c$  may be about 3.5-4.5 times the height  $h_i$  to allow for 3-4 revolutions as a band of air swirls through the cyclone chamber **1102**.

The width of each tangential cyclone inlet **1134** and **1144**, indicated as  $w_{1134}$  and  $w_{1144}$  respectively, also limits the volume of air drawn into the cyclone chamber **1102**. One or both of the widths  $w_{1134}$  and  $w_{1144}$  may be defined to be less than the radial width  $w_r$  of the cyclone chamber **1102**. The radial width  $w_r$  defines the maximum width available for a band of air to circulate within the cyclone chamber **1102**. Thus, where the widths  $w_{1134}$  and  $w_{1144}$  of each of the cyclone inlets **1134** and **1144** are less than, or equal to, the radial width  $w_r$ , backpressure caused by bands of air squeezing into the cyclone chamber **1102** may be prevented.

Each of the cyclone inlets provided by downstream outlet end **1134** and downstream outlet end **1134** may be positioned as discrete inlets around the perimeter of the cyclone chamber sidewall **1104**. For example, the cyclone inlets may be formed as slots or ports in the sidewall **1104**. As shown, the upstream outlet end **1144** of the second air flow passage **1140** is positioned downstream from the downstream outlet end **1134** of the first air flow passage **1130**, in direction of rotation **1108** of the cyclone chamber **1108**, i.e., and are separated from each other by a portion of the sidewall **1104** of the cyclone.

In the example shown, the cyclone air inlets are vertically aligned along the sidewall **1104** of the cyclone chamber **1102**. That is, each cyclone air inlet may be located at about the same vertical location in the cyclone chamber **1102**. This may ensure that more of the volume of the cyclone chamber

**1102** is used, as the bands of air from each cyclone inlet can enter at, or near, the first end of the cyclone chamber **1102**. It will be appreciated that the inlets may alternately be vertically staggered.

The tangential air inlet defined by the first airflow passage **1130** may be positioned upstream from the location at which the common airflow passage axis **1151** intersects the cyclone chamber **1102**. Shifting the tangential air inlet defined by the first airflow passage **1130** to be upstream of the axis **1151** of the common air flow passage **1150** may further separate the tangential air inlets without requiring sharp turns or bends in the air flow path.

If the inlets to the cyclone **1100** are spaced too closely together, the band of air entering the cyclone **1100** from the second airflow passage **1140** may encounter backpressure from the band of air that entered the cyclone chamber **1102** from the first airflow passage **1130**.

Without being limited by theory, air entering the cyclone chamber will commence to rotate in the rotational direction and will commence to spiral downwardly towards the opposed axial end of the cyclone. In addition, the air entering the cyclone may tend to be compressed radially inwardly as it rotates in the cyclone chamber **1102**. Therefore, air entering the cyclone chamber **1102** from the second cyclone inlet **1144** may squeeze or compress the band of air from the first airflow passage **1130** that has already entered the cyclone chamber **1102** if the inlets **1134** and **1144** are positioned close together. If the inlets **1134** and **1144** are spaced apart around the sidewall of cyclone chamber **1102**, then air entering through the upstream inlet **1134** may be compressed radially inwardly due to its rotation flow by the time that the air has travelled to the radial position of the downstream inlet **1144** and may have moved downwardly from the inlet height of the downstream inlet **1144**. Accordingly, the second band of air may encounter less resistance because the first band of air may be vertically displaced and/or compressed as it swirls around the cyclone **1100**. A counter-rotational portion **1178** can separate the cyclone inlets provided by the downstream outlet end **1134** from the downstream outlet end **1144** of the second airflow passage **1140**, without the need for an extended conduit around the cyclone **1100**.

In the example shown, the downstream outlet end **1134** of the first airflow passage **1130** defines a substantially tangential air inlet to the cyclone chamber **1102**. As with the first airflow passage **1130**, the downstream outlet end **1144** of the second airflow passage **1140** defines a tangential air inlet to the cyclone chamber **1102**. Tangential air inlets may reduce air flow losses within the air flow path.

In alternative embodiments, the surface cleaning apparatus **1000/1000A** may omit divider **1060**. That is, the surface cleaning apparatus **1000** may not include a divider member that defines a junction at the downstream end of a common airflow passage. For instance, the common airflow passage may terminate with the first and second airflow passage may extending from the outlet end of the common airflow passage. In such a case, the upstream end of the first and second air flow paths may extend in parallel with a wall separating them. In some cases, the common airflow passage may even be omitted, and the separate airflow passages may extend from the dirty air inlet **1030** to the cyclone chamber **1102**.

FIGS. 9-15 exemplifies various examples of cyclone units with multiple cyclone inlets. The cyclone units shown in FIGS. 9-15 may be used with surface cleaning apparatuses, such as the hand vacuum cleaners **1000** and **1000A** described herein above. Alternately, the cyclone units shown



in FIGS. 9-15 may be used with any surface cleaning apparatus, such as an upright surface cleaning apparatus, a stick vac, a canister surface cleaning apparatus, an extractor or the like. In the examples shown in FIGS. 9-15, a dividing member need not be used to provide a junction separating the airflow passages.

FIGS. 9A-9D illustrate an example configuration of a cyclone unit 1200 having a pair of cyclone inlets 1234 and 1244. The cyclone unit 1200 includes a cyclone chamber 1202 and a dirt collection region 1222. In the example of cyclone unit 1200, the cyclone chamber 1202 and dirt collection region 1222 are in a side-by-side configuration, with the dirt collection region partially surrounding the cyclone chamber 1202.

The cyclone unit 1200 may be positioned in the airflow path of a surface cleaning apparatus such as surface cleaning apparatuses 1000 and 1000A. Air from a dirty air inlet can be drawn through the cyclone unit 1200 using a suction motor positioned in the air flow path, and the treated air can subsequently be exhausted out a clean air outlet.

As with the cyclone chamber 1102 of surface cleaning apparatus 1000, the cyclone chamber 1202 includes a cyclone chamber sidewall 1204 that extends generally parallel to the cyclone axis (not shown, but extending into and out of the page in FIG. 9D). The air inlets to the cyclone chamber 1202 may include inlet ports formed in the sidewall 1204.

As with the surface cleaning apparatus 1000, the cyclone unit 1200 includes a vertically extending vortex finder conduit 1212, which may be provided with a screen or mesh material at the inlet to the vortex finder. The vortex finder conduit 1212 extends in a direction generally parallel to the cyclone axis. In some cases, as in FIG. 9, the cyclone axis may be located at the center of the vortex finder conduit 1212.

A plurality of airflow passages are connected to the cyclone chamber 1202. Each of the airflow passages may be fluidly isolated from one another. In the example of FIGS. 9A-9D, a first airflow passage 1230 and a second airflow passage 1240 are connected to the cyclone chamber 1202. The first airflow passage 1230 is isolated from the second airflow passage 1240 by a common wall 1250.

The first airflow passage 1230 extends from an upstream inlet (not shown) to a downstream outlet 1234 that defines a cyclone air inlet. Similarly, the second airflow passage 1240 extends from an upstream inlet (not shown) to a downstream outlet 1244 that defines a second cyclone air inlet. Each of the first cyclone air inlet 1234 and the second cyclone air inlet 1244 may be tangential air inlets that direct air into the cyclone chamber 1202 in the direction of rotation 1208 of the cyclone chamber 1202.

As shown in FIG. 9D, the first tangential air inlet 1234 has an upstream edge 1238 and a downstream edge 1239. The upstream edge 1238 is upstream from the downstream edge 1239 in the direction of rotation 1208 of the cyclone chamber 1202. This allows the air from the first air flow passage 1230 to enter the cyclone chamber 1202 as a band that is aligned with the direction of rotation 1208 of air within the cyclone.

The second tangential air inlet 1244 also has an upstream edge 1248 and a downstream edge 1249. The upstream edge 1248 is upstream from the downstream edge 1249 in the direction of rotation 1208 of the cyclone chamber 1202. This allows the air from the second air flow passage 1240 to enter the cyclone chamber 1202 as a band that is aligned with the direction of rotation 1208 of air within the cyclone. Each of

the tangential air inlets may be positioned at the same height within the cyclone chamber, as shown.

The width  $w_{1234}$  of the first tangential air inlet 1234 is defined by the distance between the upstream edge 1238 and the downstream 1239, and here corresponds to the width  $w_{1230}$  of the first air flow passage 1230. The width  $w_{1244}$  of the second tangential air inlet 1244 is defined by the distance between the upstream edge 1248 and the downstream 1249, and here corresponds to the width  $w_{1240}$  of the second air flow passage 1240. As explained above, the width  $w_{1234}$  can be equal to, or less than, a radial width  $w_{1202}$  of the cyclone chamber 1202. Similarly, the width  $w_{1244}$  of the second tangential air inlet 1240 may be less than, or equal to, the radial width  $w_{1202}$ . In the example shown, the widths  $w_{1234}$  and  $w_{1244}$  are each substantially equal to the radial width  $w_{1202}$  of the cyclone chamber 1202. By providing separate cyclone air inlets 1234 and 1244, the height  $h_i$  of each inlet can be reduced, in turn providing a reduced height  $h_c$  for the cyclone unit 1200.

The first airflow passage 1230 and the second airflow passage 1240 may terminate on the exterior of the cyclone chamber sidewall 1204. As shown, both airflow passages terminate with a cyclone air inlet at the location of the cyclone chamber sidewall 1204. The first tangential air inlet 1234 and the second tangential air inlet 1244 are provided as slots or ports in the sidewall 1204 of the cyclone chamber. The second tangential air inlet 1244 is positioned around the perimeter of the cyclone chamber sidewall 1204 downstream from the first tangential air inlet 1234 in the direction of rotation 1208.

Each of the first tangential air inlet 1234 and the second tangential air inlet 1244 direct air into the cyclone chamber 1204 in a direction perpendicular to the axis of the cyclone unit 1202. In other words, a plane transverse to the cyclone axis extends through the first and second tangential air inlets 1234/1244.

In some embodiments, the upstream edge 1248 of the second tangential air inlet 1244 may be positioned adjacent to the downstream edge 1239 of the first tangential air inlet 1234. This may reduce the length of the second airflow passage 1234. This may also allow additional cyclone air inlets to be spaced around the cyclone chamber 1202.

Alternatively, the upstream edge 1248 of the second tangential air inlet 1244 may be spaced apart from the downstream edge 1239 of the first tangential air inlet 1234 as shown in FIG. 9. A portion of the sidewall 1204 may be positioned between the upstream edge 1248 and the downstream edge 1239. This may provide separation between the bands of air entering the cyclone chamber 1202 from the first airflow passage 1230 and the second airflow passage 1240, which may allow the air bands to diverge vertically.

In some embodiments, the downstream portion of one or more of the airflow passages may be generally linear approaching the cyclone chamber 1202. As shown in the example of FIG. 9, the downstream portion of the first airflow passage 1240 extends in a generally linear direction towards the cyclone chamber 1202. In some embodiments (such as FIG. 10 below), the downstream portion of the second airflow passage 1240 may also be generally linear.

In some embodiments, a portion of one or both of the airflow passages may extend in a direction generally parallel to the cyclone axis. For example, a hand vacuum cleaner in which the cyclone is horizontally oriented may include a portion of both of the airflow passages that also extend horizontally as dirty air travels from a dirty air inlet positioned like that shown in surface cleaning apparatus 1000. Alternatively, the air flow passages may always extend

perpendicular to, or at an angle to, the cyclone axis (e.g. as with surface cleaning apparatus **1000**).

The portions of the airflow passages extending parallel to the cyclone axis may be adjacent one another. These airflow passages may abut one another, e.g. on opposite sides of a common separating wall, such as wall **1250**.

The first airflow passage **1230** and the second airflow passage **1240** may extend upstream to a dirty air inlet of the surface cleaning apparatus, such as dirty air inlet **1030** described herein above. This would provide separate dirty air inlets (e.g., the upstream ends shown in FIG. **9A** may be the dirty air inlets to the surface cleaning apparatus). An advantage of this design is that larger dirt that cannot pass through one of air flow paths **1230**, **1240** cannot enter the surface cleaning apparatus and produce a clog. In some cases, both the first airflow passage **1230** and the second airflow passage **1240** may have an inlet end that is in fluid communication with a downstream end of a single upstream airflow conduit (not shown). This upstream airflow conduit may in turn fluidly communicate with the dirty air inlet **1030**.

FIGS. **10A-10D** illustrate another example configuration of a cyclone unit **1300** that may be used with a surface cleaning apparatus, such as surface cleaning apparatuses **1000** and **1000A**. The cyclone unit **1300** includes a cyclone chamber **1302** and a dirt collection region **1322**. As with cyclone unit **1200**, cyclone unit **1300** has a pair of cyclone inlets **1334** and **1344**. However, in cyclone unit **1300** the first airflow passage **1330** is spaced apart from the second airflow passage **1340** by one or more spacers **1351**. Optionally, as shown in FIG. **12A**, a spacer may be omitted when the airflow passages are spaced apart.

As with cyclone chamber **1202**, the cyclone chamber **1302** includes a cyclone chamber sidewall **1304** that extends generally parallel to the cyclone axis **1306**. The air inlets to the cyclone chamber **1302** may include inlet ports formed in the sidewall **1304**. The cyclone chamber **1300** also includes a vertically extending vortex finder conduit **1312**.

In the example of FIGS. **10A-10D**, a first airflow passage **1330** and a second airflow passage **1340** are connected to the cyclone chamber **1302**. The first airflow passage **1330** extends, e.g., from a downstream end of a common inlet passage (not shown) to a downstream outlet **1334** that defines a first tangential cyclone air inlet. Similarly, the second airflow passage **1340** extends, e.g., from a downstream end of a common inlet passage (not shown) to a downstream outlet **1344** that defines a second tangential cyclone air inlet.

As shown in FIG. **10C**, the first tangential air inlet **1334** extends between an upstream edge **1338** and a downstream edge **1339** that is downstream from the upstream edge **1338** in the direction of rotation **1308** of the cyclone chamber **1302**. The second tangential air inlet **1344** also extends between an upstream edge **1348** and a downstream edge **1349** that is downstream from the upstream edge **1348** in the direction of rotation **1308**. Each of the tangential air inlets may be positioned at the same height within the cyclone chamber **1302**, as shown.

In the example of FIGS. **10A-10D**, the first airflow passage **1330** is isolated from the second airflow passage **1340** and is spaced apart therefrom. This may facilitate providing the second airflow passage **1340** with a generally linear downstream portion leading up to the second cyclone air inlet **1344**, without providing a conduit that extends far around the cyclone chamber **1302**.

FIGS. **11A-11D** illustrate another example configuration of a cyclone unit **1400** that may be used with a surface

cleaning apparatus, such as surface cleaning apparatuses **1000** and **1000A**. The cyclone unit **1400** includes a cyclone chamber **1402** and a dirt collection region **1422**. As with cyclone unit **1200**, cyclone unit **1400** has a pair of cyclone inlets **1434** and **1444**. However, in cyclone unit **1400** the second tangential air inlet **1444** is spaced about half way around the perimeter of the cyclone chamber sidewall **1404** from the first tangential air inlet **1434**.

As with cyclone chamber **1202**, the cyclone chamber **1402** includes a cyclone chamber sidewall **1404** that extends generally parallel to the cyclone axis **1406**. The air inlets to the cyclone chamber **1402** may include inlet ports formed in the sidewall **1404**. The cyclone chamber **1400** also includes a vertically extending vortex finder conduit **1412**.

In the example of FIGS. **11A-11D**, a first airflow passage **1430** and a second airflow passage **1440** are connected to the cyclone chamber **1402**. The first airflow passage **1430** extends, e.g., from a downstream end of a common inlet passage (not shown) to a downstream outlet **1434** that defines a first tangential cyclone air inlet. Similarly, the second airflow passage **1440** extends, e.g., from a downstream end of a common inlet passage (not shown) to a downstream outlet **1444** that defines a second tangential cyclone air inlet.

As shown in FIG. **11C**, the first tangential air inlet **1434** extends between an upstream edge **1438** and a downstream edge **1439** that is downstream from the upstream edge **1438** in the direction of rotation **1408** of the cyclone chamber **1402**. The second tangential air inlet **1444** also extends between an upstream edge **1448** and a downstream edge **1449** that is downstream from the upstream edge **1448** in the direction of rotation **1408**. Each of the tangential air inlets may be positioned at the same height within the cyclone chamber, as shown.

In the example of FIGS. **11A-11B**, the second tangential air inlet **1444** is positioned approximately opposite the first tangential air inlet **1434**. This may allow the air band that enters from the first tangential air inlet **1434** to be displaced within the cyclone chamber by a greater extent before it reaches the location of the second tangential air inlet **1444** around the perimeter of the sidewall **1404**. For this reason, the height of the cyclone chamber may be approximately half  $h_c$ , compared to a cyclone having a single air inlet.

FIGS. **12A-12D** illustrate another example configuration of a cyclone unit **1500** that may be used with a surface cleaning apparatus, such as surface cleaning apparatuses **1000** and **1000A**. The cyclone unit **1500** includes a cyclone chamber **1502** and a dirt collection region **1522**. As with cyclone unit **1300**, cyclone unit **1500** has a pair of cyclone inlets **1534** and **1544** provided at the downstream end of spaced apart air passages **1530** and **1540**. However, in cyclone unit **1500** the width of each airflow passage **1530** and **1540** (indicated as  $w_{1530}$  and  $w_{1540}$  respectively), as well as each cyclone inlet **1534** and **1544** is less than the radial width  $w_{1502}$  of the cyclone chamber **1502**. In the example shown, the width of each cyclone inlet is about half the radial width  $w_{1502}$  of the cyclone chamber **1502**.

Reducing the width of the cyclone inlets to less than the radial width of the cyclone chamber **1502** may allow the inlets to be positioned more closely together without their air bands interfering with one another. This, in turn, may allow additional cyclone inlets to be positioned around the cyclone chamber **1502** to increase the volume of air that can be drawn into the cyclone chamber **1502**.

As with cyclone chamber **1202**, the cyclone chamber **1502** includes a cyclone chamber sidewall **1504** that extends generally parallel to the cyclone axis **1506**. The air inlets to

the cyclone chamber **1502** may include inlet ports formed in the sidewall **1504**. The cyclone chamber **1500** also includes a vertically extending vortex finder conduit **1512**.

In the example of FIGS. **12A-12D**, a first airflow passage **1530** and a second airflow passage **1540** are connected to the cyclone chamber **1502**. The first airflow passage **1530** extends, e.g., from a downstream end of a common inlet passage (not shown) to a downstream outlet **1534** that defines a first tangential cyclone air inlet. Similarly, the second airflow passage **1540** extends, e.g., from a downstream end of a common inlet passage (not shown) to a downstream outlet **1544** that defines a second tangential cyclone air inlet.

As shown in FIG. **12C**, the first tangential air inlet **1534** extends between an upstream edge **1538** and a downstream edge **1539** that is downstream from the upstream edge **1538** in the direction of rotation **1508** of the cyclone chamber **1502**. The second tangential air inlet **1544** also extends between an upstream edge **1548** and a downstream edge **1549** that is downstream from the upstream edge **1548** in the direction of rotation **1508**. Each of the tangential air inlets may be positioned at the same height within the cyclone chamber, as shown.

FIGS. **13A-13D** illustrate another example configuration of a cyclone unit **1600** that may be used with a surface cleaning apparatus, such as surface cleaning apparatuses **1000** and **1000A**. The cyclone unit **1600** includes a cyclone chamber **1602** and a dirt collection region **1622**. As with cyclone unit **1300**, cyclone unit **1600** has a pair of cyclone inlets **1634** and **1644** provided at the downstream end of spaced apart air passages **1630** and **1640**. However, in cyclone unit **1600** the width of the first airflow passage **1630** (indicated as  $w_{1630}$ ) is different from the width of the second airflow passage **1640** (indicated as  $w_{1640}$ ).

As shown, the width of the first airflow passage **1630** and cyclone inlet **1634** is less than the radial width  $w_{1602}$  of the cyclone chamber **1602**. In the example shown, the width of the first cyclone inlet **1634** is about half the radial width  $w_{1602}$  of the cyclone chamber **1602**. However, the width of the second airflow passage **1640** and second cyclone inlet **1644** is about the same as the radial width  $w_{1602}$  of the cyclone chamber **1602**. This may allow a greater volume of air to enter via the second cyclone inlet **1644** with less backpressure from the band of air that entered the cyclone chamber **1602** via the first cyclone inlet **1634**.

As with cyclone chamber **1202**, the cyclone chamber **1602** includes a cyclone chamber sidewall **1604** that extends generally parallel to the cyclone axis **1606**. The air inlets to the cyclone chamber **1602** may include inlet ports formed in the sidewall **1604**. The cyclone chamber **1600** also includes a vertically extending vortex finder conduit **1612**.

In the example of FIGS. **13A-13D**, a first airflow passage **1630** and a second airflow passage **1640** are connected to the cyclone chamber **1602**. The first airflow passage **1630** extends, e.g., from a downstream end of a common inlet passage (not shown) to a downstream outlet **1634** that defines a first tangential cyclone air inlet. Similarly, the second airflow passage **1640** extends, e.g., from a downstream end of a common inlet passage (not shown) to a downstream outlet **1644** that defines a second tangential cyclone air inlet.

As shown in FIG. **13C**, the first tangential air inlet **1634** extends between an upstream edge **1638** and a downstream edge **1639** that is downstream from the upstream edge **1638** in the direction of rotation **1608** of the cyclone chamber **1602**. The second tangential air inlet **1644** also extends between an upstream edge **1648** and a downstream edge

**1649** that is downstream from the upstream edge **1648** in the direction of rotation **1608**. Each of the tangential air inlets may be positioned at the same height within the cyclone chamber, as shown.

FIGS. **14A-14D** illustrate another example configuration of a cyclone unit **1700** that may be used with a surface cleaning apparatus, such as surface cleaning apparatuses **1000** and **1000A**. The cyclone unit **1700** includes a cyclone chamber **1702** and a dirt collection region **1722**.

The cyclone unit **1700** includes three cyclone inlets **1734**, **1744** and **1774** positioned at the downstream end of first, second and third separate airflow passages **1730**, **1740**, and **1770** respectively. As shown in the example of FIGS. **14A-14D**, the first airflow passage **1730** is spaced apart from the second airflow passage **1740**. This may facilitate providing a linear downstream portion in the second airflow passage **1740**. As shown, the second airflow passage **1740** and third airflow passage **1770** are adjacent one another, but separated by a dividing wall.

As shown, the width of each airflow passage **1730**, **1740**, and **1770** is less than the radial width of the cyclone chamber **1702**. This may facilitate air bands entering from additional outlets positioned substantially aligned around the perimeter of the cyclone chamber sidewall **1704**.

As with cyclone chamber **1202**, the cyclone chamber **1702** includes a cyclone chamber sidewall **1704** that extends generally parallel to the cyclone axis. The air inlets to the cyclone chamber **1702** may include inlet ports formed in the sidewall **1704**. The cyclone chamber **1700** also includes a vertically extending vortex finder conduit **1712**.

In the example of FIGS. **14A-14D**, a first airflow passage **1730**, a second airflow passage **1740**, and a third airflow passage **1770** are connected to the cyclone chamber **1702**. The first airflow passage **1730** extends, e.g., from a downstream end of a common inlet passage (not shown) to a downstream outlet **1734** that defines a first tangential cyclone air inlet. The second airflow passage **1740** extends, e.g., from a downstream end of a common inlet passage (not shown) to a downstream outlet **1744** that defines a second tangential cyclone air inlet. The third airflow passage **1770** also extends, e.g., from a downstream end of a common inlet passage (not shown) to a downstream outlet **1774** that defines a third tangential cyclone air inlet.

As shown in FIG. **14C**, the first tangential air inlet **1734** extends between an upstream edge **1738** and a downstream edge **1739** that is downstream from the upstream edge **1738** in the direction of rotation **1708** of the cyclone chamber **1702**. The second tangential air inlet **1744** also extends between an upstream edge **1748** and a downstream edge **1749** that is downstream from the upstream edge **1748** in the direction of rotation **1708**. The third tangential air inlet **1774** also extends between an upstream edge **1778** and a downstream edge **1779** that is downstream from the upstream edge **1778** in the direction of rotation **1708**. Each of the tangential air inlets may be positioned at the same height within the cyclone chamber (i.e. substantially aligned along the longitudinal extent of the cyclone chamber).

FIG. **15** illustrates an example configuration of a cyclone unit **1800** that may be used with a surface cleaning apparatus, such as surface cleaning apparatuses **1000** and **1000A**. As with cyclone unit **1700**, the cyclone unit **1800** includes three cyclone inlets **1834**, **1844** and **1874** positioned at the downstream end of first, second and third separate airflow passages **1830**, **1840**, and **1870** respectively. However, in the example of FIG. **15**, the first airflow passage **1830** is

adjacent to the second airflow passage **1840**, and the second airflow passage **1840** and third airflow passage **1870** are adjacent one another.

As shown, the width of each airflow passage **1830**, **1840**, and **1870** is about the same as, or slightly less than the radial width of the cyclone chamber **1802**. This may allow a greater volume of air to enter the cyclone chamber **1802** with a reduce height for each inlet.

As with cyclone chamber **1202**, the cyclone chamber **1802** includes a cyclone chamber sidewall **1804** that extends generally parallel to the cyclone axis. The air inlets to the cyclone chamber **1802** may include inlet ports formed in the sidewall **1804**. The cyclone chamber **1800** also includes a vertically extending vortex finder conduit **1812**.

In the example of FIG. **15**, a first airflow passage **1830**, a second airflow passage **1840**, and a third airflow passage **1870** are connected to the cyclone chamber **1802**. The first airflow passage **1830** extends, e.g., from a downstream end of a common inlet passage (not shown) to a downstream outlet **1834** that defines a first tangential cyclone air inlet. The second airflow passage **1840** extends, e.g., from a downstream end of a common inlet passage (not shown) to a downstream outlet **1844** that defines a second tangential cyclone air inlet. The third airflow passage **1870** also extends, e.g., from a downstream end of a common inlet passage (not shown) to a downstream outlet **1874** that defines a third tangential cyclone air inlet.

The first tangential air inlet **1834** extends between an upstream edge **1838** and a downstream edge **1839** that is downstream from the upstream edge **1838** in the direction of rotation **1808** of the cyclone chamber **1802**. The second tangential air inlet **1844** also extends between an upstream edge **1848** and a downstream edge **1849** that is downstream from the upstream edge **1848** in the direction of rotation **1808**. The third tangential air inlet **1874** also extends between an upstream edge **1878** and a downstream edge **1879** that is downstream from the upstream edge **1878** in the direction of rotation **1808**. Each of the tangential air inlets may be positioned at the same height within the cyclone chamber, as shown.

As used herein, the wording “and/or” is intended to represent an inclusive—or. That is, “X and/or Y” is intended to mean X or Y or both, for example. As a further example, “X, Y, and/or Z” is intended to mean X or Y or Z or any combination thereof.

While the above description describes features of example embodiments, it will be appreciated that some features and/or functions of the described embodiments are susceptible to modification without departing from the spirit and principles of operation of the described embodiments. For example, the various characteristics which are described by means of the represented embodiments or examples may be selectively combined with each other. Accordingly, what has been described above is intended to be illustrative of the claimed concept and non-limiting. It will be understood by persons skilled in the art that other variants and modifications may be made without departing from the scope of the invention as defined in the claims appended hereto. The scope of the claims should not be limited by the preferred embodiments and examples, but should be given the broadest interpretation consistent with the description as a whole.

The invention claimed is:

1. A vacuum cleaner comprising:

(a) an air flow path extending from a dirty air inlet to a clean air outlet with a suction motor positioned in the air flow path; and,

(b) a cyclone positioned in the air flow path, the cyclone having a cyclone chamber, a cyclone chamber sidewall, a first airflow passage having an inlet end and a downstream outlet end wherein the downstream outlet end comprises a first tangential air inlet, a second airflow passage having an inlet end and a downstream outlet end wherein the downstream outlet end comprises a second tangential air inlet, a cyclone air outlet and a longitudinal cyclone axis about which the air rotates in the cyclone chamber in a direction of rotation of air in the cyclone chamber,

wherein the air flow path comprises a common airflow passage upstream of the first and second airflow passages with a divider located at a downstream end of the common airflow passage and an upstream end of the first and second airflow passages, the divider has an upstream side that extends towards the downstream end of the common airflow passage and an axis of the common airflow passage intersects the cyclone chamber,

wherein the second tangential air inlet is positioned around a perimeter of the cyclone chamber sidewall downstream from the first tangential air inlet in the direction of rotation of air in the cyclone chamber, and wherein at least a portion of the first tangential air inlet is positioned upstream from a location at which the common airflow passage axis intersects the cyclone chamber.

2. The vacuum cleaner of claim **1** wherein at least a portion of the first airflow passage extends in a counter rotational direction.

3. The vacuum cleaner of claim **1** wherein the common airflow passage extends downstream from the dirty air inlet and the common airflow passage extends generally linearly to the first and second airflow passages.

4. The vacuum cleaner of claim **1** wherein the divider comprises a convex member that extends towards the downstream end of the common airflow passage.

5. The vacuum cleaner of claim **4** wherein the convex member has a first portion that comprises a wall at an inlet end to the first airflow passage and a second portion that comprises a wall at an inlet end to the second airflow passage.

6. The vacuum cleaner of claim **5** wherein the second airflow passage extends generally linearly from the convex member to the second tangential air inlet and at least a portion of the first airflow passage extends in a counter rotational direction from the convex member to the first tangential air inlet.

7. The vacuum cleaner of claim **1** wherein the axis of the common airflow passage intersects the divider.

8. The vacuum cleaner of claim **7** wherein the divider comprises a convex member that extends towards the downstream end of the common airflow passage.

9. The vacuum cleaner of claim **7** wherein the divider has a first portion that comprises a wall at an inlet end to the first airflow passage and a second portion that comprises a wall at an inlet end to the second airflow passage.

10. The vacuum cleaner of claim **9** wherein the second airflow passage extends generally linearly from the divider to the second tangential air inlet and at least a portion of the first airflow passage extends in a counter rotational direction from the divider to the first tangential air inlet.

11. A vacuum cleaner comprising:

(a) an air flow path extending from a dirty air inlet to a clean air outlet with a suction motor positioned in the air flow path; and,

23

(b) a cyclone positioned in the air flow path, the cyclone having a cyclone chamber, a cyclone chamber sidewall, a first airflow passage having an inlet end and a downstream outlet end wherein the downstream outlet end comprises a first tangential air inlet, a second airflow passage having an inlet end and a downstream outlet end wherein the downstream outlet end comprises a second tangential air inlet, a cyclone air outlet and a longitudinal cyclone axis about which the air rotates in the cyclone chamber in a direction of rotation of air in the cyclone chamber,

wherein the air flow path comprises a common airflow passage upstream of the first and second airflow passages with a divider located at a downstream end of the common airflow passage, the divider extends across a portion of the downstream end of the common air flow passage, and an upstream end of the first and second airflow passages are provided on laterally opposed sides of the divider,

wherein the second tangential air inlet is positioned around a perimeter of the cyclone chamber sidewall downstream from the first tangential air inlet in the direction of rotation of air in the cyclone chamber, and wherein at least a portion of the first airflow passage extends in a counter rotational direction and the second airflow passage extends in the direction of rotation.

12. The vacuum cleaner of claim 11 wherein the common airflow passage extends downstream from the dirty air inlet and the common airflow passage extends generally linearly to the first and second airflow passages.

13. The vacuum cleaner of claim 1 wherein the vacuum cleaner has an absence of an annular flow region extending around the cyclone and positioned upstream of the tangential air inlets.

24

14. The vacuum cleaner of claim 11 wherein the vacuum cleaner has an absence of an annular flow region extending around the cyclone and positioned upstream of the tangential air inlets.

15. The vacuum cleaner of claim 11 further comprising a convex member that extends towards the downstream end of the common airflow passage.

16. The vacuum cleaner of claim 15 wherein the convex member has a first portion that comprises a wall at an inlet end to the first airflow passage and a second portion that comprises a wall at an inlet end to the second airflow passage.

17. The vacuum cleaner of claim 16 wherein the second airflow passage extends generally linearly from the convex member to the second tangential air inlet and the at least a portion of the first airflow passage extends in a counter rotational direction from the convex member to the first tangential air inlet.

18. The vacuum cleaner of claim 11 wherein the axis of the common airflow passage intersects the divider.

19. The vacuum cleaner of claim 18 wherein the divider comprises a convex member that extends towards the downstream end of the common airflow passage.

20. The vacuum cleaner of claim 18 wherein the divider has a first portion that comprises a wall at an inlet end to the first airflow passage and a second portion that comprises a wall at an inlet end to the second airflow passage.

21. The vacuum cleaner of claim 20 wherein the second airflow passage extends generally linearly from the divider to the second tangential air inlet and the at least a portion of the first airflow passage extends in a counter rotational direction from the divider to the first tangential air inlet.

\* \* \* \* \*