



(12) **United States Patent**
Conrad

(10) **Patent No.:** **US 10,602,894 B2**
(45) **Date of Patent:** **Mar. 31, 2020**

(54) **PORTABLE SURFACE CLEANING APPARATUS**

(2013.01); *A47L 9/1691* (2013.01); *A47L 9/242* (2013.01); *A47L 9/2842* (2013.01); *A47L 9/2857* (2013.01); *A47L 9/2894* (2013.01); *A47L 9/322* (2013.01)

(71) Applicant: **Omachron Intellectual Property Inc., Hampton (CA)**

(58) **Field of Classification Search**

CPC *A47L 9/1608*; *A47L 9/1666*; *A47L 5/365*; *A47L 5/24*
USPC 15/327.1–327.7, 323, 344, 347
See application file for complete search history.

(72) Inventor: **Wayne Ernest Conrad, Hampton (CA)**

(73) Assignee: **Omachron Intellectual Property Inc., Hampton, Ontario (CA)**

(*) Notice: Subject to any disclaimer, the term of this patent is extended or adjusted under 35 U.S.C. 154(b) by 0 days.

(56) **References Cited**

U.S. PATENT DOCUMENTS

911,258 A 2/1909 Neumann
1,600,762 A 9/1926 Hawley
(Continued)

(21) Appl. No.: **15/499,151**

(22) Filed: **Apr. 27, 2017**

FOREIGN PATENT DOCUMENTS

(65) **Prior Publication Data**

US 2017/0224182 A1 Aug. 10, 2017

AU 1127788 A 8/1988
CA 1077412 A1 5/1980
(Continued)

Related U.S. Application Data

(63) Continuation of application No. 14/932,816, filed on Nov. 4, 2015, now Pat. No. 9,693,666, which is a (Continued)

OTHER PUBLICATIONS

English machine translation of DE202011003563U1 published on May 19, 2011.

(Continued)

(51) **Int. Cl.**

A47L 9/10 (2006.01)
A47L 5/24 (2006.01)
A47L 9/00 (2006.01)
A47L 9/16 (2006.01)
A47L 9/28 (2006.01)
A47L 9/12 (2006.01)
A47L 9/14 (2006.01)

Primary Examiner — Joseph J Hail
Assistant Examiner — Shantese L McDonald
(74) *Attorney, Agent, or Firm* — Philip C. Mendes da Costa; Bereskin & Parr LLP/S.E.N.C.R.L. s.r.l.

(Continued)

(57) **ABSTRACT**

A portable surface cleaning apparatus has a main body, an air treatment member and a handle wherein the dirty air inlet is provided in the front face at a location below the horizontal plane, and wherein the handle overlies a portion of the cyclone chamber and the suction motor.

(52) **U.S. Cl.**

CPC *A47L 5/24* (2013.01); *A47L 9/0018* (2013.01); *A47L 9/0027* (2013.01); *A47L 9/0036* (2013.01); *A47L 9/12* (2013.01); *A47L 9/149* (2013.01); *A47L 9/1608* (2013.01); *A47L 9/1666* (2013.01); *A47L 9/1683*

7 Claims, 13 Drawing Sheets

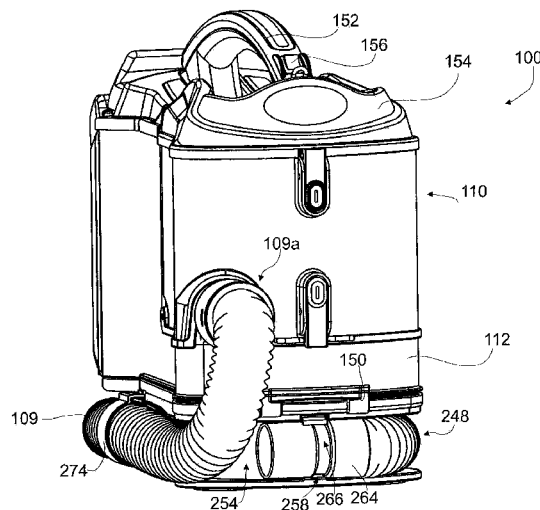

Related U.S. Application Data						
continuation of application No. 13/040,676, filed on Mar. 4, 2011, now Pat. No. 9,211,044.						
(51)	Int. Cl.					
	<i>A47L 9/24</i>	(2006.01)				
	<i>A47L 9/32</i>	(2006.01)				
(56)	References Cited					
	U.S. PATENT DOCUMENTS					
	1,779,761 A	10/1930	Alford, Sr.	4,678,588 A	7/1987	Shortt
	1,797,812 A	3/1931	Waring	4,744,958 A	5/1988	Pircon
	1,898,608 A	2/1933	Alexander	4,778,494 A	10/1988	Patterson
	1,937,765 A	12/1933	Leathers	4,790,865 A	12/1988	DeMarco
	2,015,464 A	9/1935	Saint-Jacques	4,809,393 A	3/1989	Goodrich et al.
	2,071,975 A	2/1937	Holm-Hansen et al.	4,809,398 A	3/1989	Lindquist et al.
	2,152,114 A	3/1939	Tongeren	4,826,515 A	5/1989	Dyson
	2,533,057 A	12/1950	Senne	4,831,685 A	5/1989	Bosyj et al.
	2,542,634 A	2/1951	Davis et al.	4,836,515 A	6/1989	Franz et al.
	2,559,384 A	7/1951	Anderson, Jr.	4,853,008 A	8/1989	Dyson
	2,621,756 A	12/1952	Senne	4,853,011 A	8/1989	Dyson
	2,632,524 A	3/1953	Senne	4,905,342 A	3/1990	Ataka
	2,678,110 A	5/1954	Madsen	5,054,157 A	10/1991	Werner et al.
	2,731,102 A	1/1956	James	5,078,761 A	1/1992	Dyson
	2,811,219 A	10/1957	Wenzl	5,080,697 A	1/1992	Finke
	2,846,024 A	8/1958	Bremi	5,090,976 A	2/1992	Dyson
	2,913,111 A	11/1959	Rogers	5,129,125 A	7/1992	Gamou et al.
	2,917,131 A	12/1959	Evans	5,139,652 A	8/1992	LeBlanc
	2,937,713 A	5/1960	Stephenson et al.	5,230,722 A	7/1993	Yonkers
	2,942,691 A	6/1960	Dillon	5,254,019 A	10/1993	Noschese
	2,942,692 A	6/1960	Benz	5,267,371 A	12/1993	Soler et al.
	2,946,451 A	7/1960	Culleton	5,287,591 A	2/1994	Rench et al.
	2,952,330 A	9/1960	Winslow	5,309,600 A	5/1994	Weaver et al.
	2,981,369 A	4/1961	Yellott et al.	5,309,601 A	5/1994	Hampton et al.
	3,015,122 A	1/1962	Cook	5,331,714 A	7/1994	Essex et al.
	3,023,838 A	3/1962	Gaudry	5,391,051 A	2/1995	Sabatier et al.
	3,032,954 A	5/1962	Racklyeft	5,481,780 A	1/1996	Daneshvar
	3,085,221 A	4/1963	Kelly	5,524,321 A	6/1996	Weaver et al.
	3,130,157 A	4/1964	Kelsall et al.	5,599,365 A	2/1997	Alday et al.
	3,200,568 A	8/1965	McNeil	5,681,450 A	10/1997	Chitnis et al.
	3,204,772 A	9/1965	Ruxton	5,715,566 A	2/1998	Weaver et al.
	3,217,469 A	11/1965	Eckert	5,755,096 A	5/1998	Holleyman
	3,269,097 A	8/1966	German	5,836,047 A	11/1998	Lee et al.
	3,310,828 A	3/1967	Clark et al.	5,842,254 A	12/1998	Lee
	3,320,727 A	5/1967	Farley et al.	5,858,038 A	1/1999	Dyson et al.
	3,356,334 A	12/1967	Scaramucci	5,858,043 A	1/1999	Geise
	3,372,532 A	3/1968	Campbell	5,893,938 A	4/1999	Dyson et al.
	3,426,513 A	2/1969	Bauer	5,922,093 A	7/1999	James et al.
	3,457,744 A	7/1969	Bisbing	5,935,279 A	8/1999	Kilstroem
	3,518,815 A	7/1970	Peterson et al.	5,950,274 A	9/1999	Kilstrom
	3,530,649 A	9/1970	Porsch et al.	5,958,094 A	9/1999	Schwamborn et al.
	3,561,824 A	2/1971	Homan	6,026,540 A	2/2000	Wright et al.
	3,582,616 A	6/1971	Wrob	6,058,559 A	5/2000	Yoshimi et al.
	3,675,401 A	7/1972	Cordes	6,070,291 A	6/2000	Bair et al.
	3,684,093 A	8/1972	Kono et al.	6,071,095 A	6/2000	Verkaart
	3,788,044 A	1/1974	McNeil	6,071,321 A	6/2000	Trapp et al.
	3,822,533 A	7/1974	Oranje	6,080,022 A	6/2000	Shaberman et al.
	3,898,068 A	8/1975	McNeil	6,081,961 A	7/2000	Wang
	3,933,450 A	1/1976	Percevaut	6,122,796 A	9/2000	Downham et al.
	3,953,184 A	4/1976	Stockford et al.	6,168,641 B1	1/2001	Tuvin et al.
	3,960,734 A	6/1976	Zagorski	6,171,356 B1	1/2001	Twerdun
	3,988,132 A	10/1976	Oranje	6,173,474 B1	1/2001	Conrad
	3,988,133 A	10/1976	Schady	6,192,550 B1	2/2001	Hamada et al.
	4,097,381 A	6/1978	Ritzler	6,210,469 B1	4/2001	Tokar
	4,187,088 A	2/1980	Hodgson	6,221,134 B1	4/2001	Conrad et al.
	4,218,805 A	8/1980	Brazier	6,228,260 B1	5/2001	Conrad et al.
	4,236,903 A	12/1980	Malmsten	6,231,645 B1	5/2001	Conrad et al.
	4,373,228 A	2/1983	Dyson	6,251,296 B1	6/2001	Conrad et al.
	4,382,804 A	5/1983	Mellor	6,256,832 B1	7/2001	Dyson
	4,393,536 A	7/1983	Tapp	6,256,834 B1	7/2001	Meijer et al.
	4,409,008 A	10/1983	Solymes	6,260,234 B1	7/2001	Wright et al.
	4,443,910 A	4/1984	Fitzwater	6,295,692 B1	10/2001	Shideler
	4,486,207 A	12/1984	Baillie	6,334,234 B1	1/2002	Conrad et al.
	4,573,236 A	3/1986	Dyson	6,353,963 B1	3/2002	Bair et al.
	4,635,315 A	1/1987	Kozak	6,398,834 B2	6/2002	Oh
				6,406,505 B1	6/2002	Oh et al.
				6,432,154 B2	8/2002	Oh et al.
				6,434,785 B1	8/2002	Vandenbelt et al.
				6,440,197 B1	8/2002	Conrad et al.
				6,463,622 B2	10/2002	Wright et al.
				6,482,246 B1	11/2002	Dyson et al.
				6,510,583 B2	1/2003	Griffin et al.
				6,531,066 B1	3/2003	Saunders et al.
				6,532,620 B2	3/2003	Oh
				6,553,612 B1	4/2003	Dyson et al.
				6,560,818 B1	5/2003	Hasko
				6,581,239 B1	6/2003	Dyson et al.
				6,599,338 B2	7/2003	Oh et al.
				6,599,350 B1	7/2003	Rockwell et al.

(56)

References Cited

U.S. PATENT DOCUMENTS

6,613,316 B2	9/2003	Sun et al.	7,779,506 B2	8/2010	Kang et al.
6,623,539 B2	9/2003	Lee et al.	7,803,205 B2	9/2010	Oh et al.
6,625,845 B2	9/2003	Matsumoto et al.	7,803,207 B2	9/2010	Conrad
6,648,934 B2	11/2003	Choi et al.	7,867,308 B2	1/2011	Conrad
6,706,095 B2	3/2004	Morgan	7,882,592 B2	2/2011	Hwang et al.
6,735,818 B2	5/2004	Hamada et al.	7,887,612 B2	2/2011	Conrad
6,736,873 B2	5/2004	Conrad et al.	7,922,794 B2	4/2011	Morphey
6,746,500 B1	6/2004	Park et al.	7,934,286 B2	5/2011	Yoo et al.
6,782,583 B2	8/2004	Oh	7,938,871 B2	5/2011	Lloyd
6,782,585 B1	8/2004	Conrad et al.	7,941,895 B2	5/2011	Conrad
6,810,558 B2	11/2004	Lee	7,979,953 B2	7/2011	Yoo
6,832,408 B2	12/2004	Roney et al.	8,015,659 B2	9/2011	Conrad et al.
6,833,015 B2	12/2004	Oh et al.	8,021,453 B2	9/2011	Howes
6,848,146 B2	2/2005	Wright et al.	8,032,981 B2	10/2011	Yoo
6,868,578 B1	3/2005	Kasper et al.	8,032,983 B2	10/2011	Griffith et al.
6,874,197 B1	4/2005	Conrad et al.	8,034,140 B2	10/2011	Conrad
6,896,719 B2	5/2005	Coates et al.	8,048,180 B2	11/2011	Oh et al.
6,901,625 B2	6/2005	Yang et al.	8,062,398 B2	11/2011	Luo et al.
6,902,596 B2	6/2005	Conrad et al.	8,100,999 B2	1/2012	Ashbee et al.
6,910,245 B2	6/2005	Hawkins et al.	8,117,713 B2	2/2012	Kasper et al.
6,929,516 B2	8/2005	Brochu et al.	8,127,397 B2	3/2012	Hess et al.
6,961,975 B2	11/2005	Park et al.	8,127,398 B2	3/2012	Conrad
6,968,596 B2	11/2005	Oh et al.	8,166,607 B2	5/2012	Conrad
6,976,885 B2	12/2005	Lord	8,191,203 B2	6/2012	Yoo
7,036,183 B2	5/2006	Gammack et al.	8,296,900 B2	10/2012	Conrad
7,039,985 B2	5/2006	Hisrich et al.	8,359,705 B2	1/2013	Conrad
7,065,826 B1	6/2006	Arnold	8,468,464 B2	6/2013	Abramson et al.
7,073,226 B1	7/2006	Lenkiewicz et al.	8,468,646 B2	6/2013	Yoo
7,086,119 B2	8/2006	Go et al.	8,484,799 B2	7/2013	Conrad
7,127,397 B2	10/2006	Case	8,528,160 B2	9/2013	Conrad
7,131,165 B2	11/2006	Wright et al.	8,769,767 B2	7/2014	Conrad
7,146,681 B2	12/2006	Wright et al.	2001/0054213 A1	12/2001	Oh et al.
7,160,346 B2	1/2007	Park	2002/0011050 A1	1/2002	Hansen et al.
7,175,682 B2	2/2007	Nakai et al.	2002/0020154 A1	2/2002	Yang
7,207,083 B2	4/2007	Hayashi et al.	2002/0026775 A1	3/2002	Murphy et al.
7,222,393 B2	5/2007	Kaffenberger et al.	2002/0062531 A1	5/2002	Oh
7,278,181 B2	10/2007	Harris et al.	2002/0088208 A1	7/2002	Lukac et al.
7,309,365 B2	12/2007	Yuasa et al.	2002/0112315 A1	8/2002	Conrad
7,341,611 B2	3/2008	Greene et al.	2002/0124538 A1	9/2002	Oh et al.
7,354,468 B2	4/2008	Arnold et al.	2002/0134059 A1	9/2002	Oh
7,356,874 B2	4/2008	Skinner Macleod et al.	2002/0162188 A1	11/2002	Harmen
7,370,387 B2	5/2008	Walker et al.	2002/0178535 A1	12/2002	Oh et al.
7,377,008 B2	5/2008	Park et al.	2002/0178698 A1	12/2002	Oh et al.
7,377,953 B2	5/2008	Oh	2002/0178699 A1	12/2002	Oh
7,380,308 B2	6/2008	Oh et al.	2003/0028994 A1	2/2003	Kitamura et al.
7,381,234 B2	6/2008	Oh	2003/0158238 A1	8/2003	Hale et al.
7,386,916 B2	6/2008	Bone	2003/0159238 A1	8/2003	Oh
7,395,579 B2	7/2008	Oh	2003/0159411 A1	8/2003	Hansen et al.
7,410,516 B2	8/2008	Ivarsson et al.	2003/0200736 A1	10/2003	Ni
7,419,521 B2	9/2008	Oh et al.	2003/0226232 A1*	12/2003	Hayashi A47L 5/362 15/353
D581,609 S	11/2008	Conrad et al.	2004/0010885 A1	1/2004	Hitzelberger et al.
7,448,363 B1	11/2008	Rasmussen et al.	2004/0025285 A1	2/2004	McCormick et al.
7,449,040 B2	11/2008	Conrad et al.	2004/0060146 A1	4/2004	Coates et al.
7,485,164 B2	2/2009	Jeong et al.	2004/0112022 A1	6/2004	Vuijk
7,488,363 B2	2/2009	Jeong et al.	2004/0163201 A1	8/2004	Murphy et al.
7,544,224 B2	6/2009	Tanner et al.	2004/0194249 A1	10/2004	Lee et al.
7,547,338 B2	6/2009	Kim et al.	2004/0216263 A1	11/2004	Best et al.
7,555,810 B2	7/2009	Pullins et al.	2004/0216264 A1	11/2004	Shaver et al.
7,581,286 B2	9/2009	Choi	2004/0216266 A1	11/2004	Conrad
7,588,616 B2	9/2009	Conrad et al.	2004/0237248 A1	12/2004	Oh et al.
7,594,296 B2	9/2009	Park	2004/0261213 A1	12/2004	Park et al.
7,597,730 B2	10/2009	Yoo et al.	2005/0000054 A1	1/2005	Ninomiya et al.
7,604,675 B2	10/2009	Makarov et al.	2005/0050678 A1	3/2005	Oh et al.
7,618,470 B2	11/2009	Eddington et al.	2005/0125939 A1	6/2005	Hansen et al.
7,624,475 B2	12/2009	Choi	2005/0132529 A1	6/2005	Davidshofer
7,645,309 B2	1/2010	Jeong et al.	2005/0138757 A1	6/2005	Lee
7,645,311 B2	1/2010	Oh et al.	2005/0144754 A1	7/2005	Ivarsson et al.
7,686,858 B2	3/2010	Oh	2005/0198767 A1	9/2005	Kang et al.
7,731,769 B2	6/2010	Min	2005/0198769 A1	9/2005	Lee et al.
7,736,408 B2	6/2010	Böck et al.	2005/0198770 A1	9/2005	Jung et al.
7,740,676 B2	6/2010	Burnham et al.	2005/0252179 A1	11/2005	Oh et al.
7,776,116 B2	8/2010	Oh et al.	2006/0005346 A1	1/2006	Rupp et al.
7,776,120 B2	8/2010	Conrad	2006/0037172 A1	2/2006	Choi
7,779,505 B2*	8/2010	Krebs A47L 5/225 15/320	2006/0080947 A1	4/2006	Lee et al.
			2006/0090290 A1	5/2006	Lau
			2006/0123590 A1	6/2006	Fester et al.
			2006/0137304 A1	6/2006	Jeong et al.
			2006/0137305 A1	6/2006	Jung

(56)

References Cited

U.S. PATENT DOCUMENTS

2006/0137306 A1 6/2006 Jeong et al.
 2006/0137307 A1 6/2006 Jeong et al.
 2006/0137309 A1 6/2006 Jeong et al.
 2006/0156508 A1* 7/2006 Khalil A47L 5/24
 15/353
 2006/0156509 A1 7/2006 Luebbering et al.
 2006/0156699 A1* 7/2006 Kim A47L 9/1608
 55/345
 2006/0162298 A1 7/2006 Oh et al.
 2006/0162299 A1 7/2006 North
 2006/0168923 A1 8/2006 Lee et al.
 2006/0191099 A1 8/2006 Fry et al.
 2006/0207231 A1 9/2006 Arnold
 2006/0230715 A1 10/2006 Oh et al.
 2006/0230724 A1 10/2006 Han et al.
 2006/0230726 A1 10/2006 Oh et al.
 2006/0236663 A1 10/2006 Oh
 2006/0248678 A1 11/2006 Park
 2006/0278081 A1 12/2006 Han et al.
 2007/0012002 A1 1/2007 Oh et al.
 2007/0039120 A1 2/2007 Choi
 2007/0067944 A1 3/2007 Kitamura et al.
 2007/0067945 A1* 3/2007 Kasper A47L 7/0028
 15/353
 2007/0077810 A1 4/2007 Gogel et al.
 2007/0079473 A1 4/2007 Min et al.
 2007/0079584 A1 4/2007 Kim et al.
 2007/0079585 A1* 4/2007 Oh A47L 9/1625
 55/345
 2007/0079587 A1* 4/2007 Kim A47L 9/1608
 55/349
 2007/0084160 A1 4/2007 Kim
 2007/0084161 A1 4/2007 Yoo
 2007/0095028 A1 5/2007 Kim et al.
 2007/0095029 A1 5/2007 Min et al.
 2007/0209334 A1 9/2007 Conrad
 2007/0226946 A1 10/2007 Best
 2007/0226947 A1 10/2007 Kang
 2007/0240275 A1 10/2007 Willenbring
 2007/0251048 A1* 11/2007 Choi A47L 5/225
 15/329
 2007/0262512 A1 11/2007 Watanabe et al.
 2007/0266683 A1 11/2007 McDowell
 2007/0271724 A1 11/2007 Hakan et al.
 2007/0289085 A1 12/2007 Yoo
 2007/0289089 A1 12/2007 Yacobi
 2007/0289267 A1 12/2007 Makarov et al.
 2008/0040883 A1 2/2008 Beskow et al.
 2008/0047091 A1 2/2008 Nguyen
 2008/0083085 A1 4/2008 Genn
 2008/0104793 A1 5/2008 Kang et al.
 2008/0115312 A1 5/2008 DiPasquale et al.
 2008/0134460 A1 6/2008 Conrad
 2008/0134462 A1 6/2008 Jansen et al.
 2008/0172821 A1 7/2008 Kang et al.
 2008/0172992 A1* 7/2008 Conrad A47L 5/24
 55/323
 2008/0172995 A1 7/2008 Conrad
 2008/0178416 A1 7/2008 Conrad
 2008/0184681 A1 8/2008 Oh et al.
 2008/0190080 A1 8/2008 Oh et al.
 2008/0196194 A1 8/2008 Conrad
 2008/0196196 A1 8/2008 Conrad
 2008/0216282 A1 9/2008 Conrad
 2008/0250601 A1 10/2008 Coburn
 2008/0282497 A1* 11/2008 Griffith A47L 9/1691
 15/352
 2009/0000054 A1 1/2009 Hampton et al.
 2009/0031522 A1 2/2009 Yoo et al.
 2009/0044371 A1 2/2009 Yoo et al.
 2009/0106932 A1 4/2009 Courtney
 2009/0113659 A1 5/2009 Jeon et al.
 2009/0113663 A1 5/2009 Follows et al.
 2009/0133370 A1 5/2009 Yoo et al.

2009/0144929 A1 6/2009 Yoo
 2009/0144932 A1 6/2009 Yoo
 2009/0165431 A1 7/2009 Oh
 2009/0178229 A1 7/2009 Yoo
 2009/0178568 A1 7/2009 Yoo
 2009/0181841 A1 7/2009 Conrad
 2009/0193610 A1 8/2009 Gabric
 2009/0193771 A1 8/2009 Oh et al.
 2009/0205160 A1 8/2009 Conrad
 2009/0205161 A1 8/2009 Conrad
 2009/0209403 A1 8/2009 Conrad
 2009/0209666 A1 8/2009 Hellberg et al.
 2009/0217635 A1 9/2009 Bertram et al.
 2009/0300873 A1 12/2009 Grey
 2009/0307864 A1 12/2009 Dyson
 2010/0005611 A1 1/2010 Hong et al.
 2010/0005617 A1 1/2010 Hyun et al.
 2010/0037420 A1 2/2010 Lee
 2010/0043170 A1 2/2010 Ni
 2010/0071153 A1 3/2010 Genn
 2010/0095476 A1 4/2010 Kim et al.
 2010/0115727 A1 5/2010 Oh
 2010/0162515 A1 7/2010 Stephens
 2010/0175217 A1 7/2010 Conrad
 2010/0175219 A1 7/2010 Soen et al.
 2010/0212104 A1* 8/2010 Conrad A47L 5/24
 15/347
 2010/0224073 A1 9/2010 Oh et al.
 2010/0229336 A1 9/2010 Conrad
 2010/0229338 A1 9/2010 Conrad
 2010/0242222 A1 9/2010 Conrad
 2010/0293745 A1 11/2010 Coburn
 2010/0299865 A1 12/2010 Conrad
 2011/0023262 A1 2/2011 Conrad
 2011/0214250 A1 9/2011 McLeod et al.
 2011/0219570 A1 9/2011 Conrad
 2011/0219573 A1 9/2011 Conrad
 2011/0219574 A1 9/2011 Conrad
 2011/0314629 A1 12/2011 Conrad
 2012/0000030 A1 1/2012 Conrad
 2012/0030895 A1 2/2012 Chong et al.
 2012/0030898 A1 2/2012 Crouch et al.
 2012/0047682 A1 3/2012 Makarov et al.
 2012/0159734 A1 6/2012 Fujiwara
 2012/0180662 A1 7/2012 Missalla et al.
 2012/0222235 A1 9/2012 Lenkiewicz et al.
 2012/0222245 A1 9/2012 Conrad
 2012/0272472 A1 11/2012 Conrad
 2013/0091660 A1 4/2013 Smith
 2013/0091661 A1 4/2013 Smith
 2013/0091812 A1 4/2013 Smith
 2013/0091813 A1 4/2013 Smith
 2013/0104335 A1 5/2013 Conrad
 2013/0145575 A1 6/2013 Conrad
 2014/0237768 A1 8/2014 Conrad
 2016/0367094 A1 12/2016 Conrad

FOREIGN PATENT DOCUMENTS

CA 2438079 A1 9/2002
 CA 2658014 A1 9/2010
 CN 2524655 Y 12/2002
 CN 2534954 Y 2/2003
 CN 1506016 A 6/2004
 CN 1765283 A 5/2006
 CN 1806741 A 7/2006
 CN 1875855 A 12/2006
 CN 1887437 A 1/2007
 CN 1895148 A 1/2007
 CN 101073480 A 11/2007
 CN 201101488 Y 8/2008
 CN 101357051 A 2/2009
 CN 201290642 Y 8/2009
 CN 101657133 A 2/2010
 CN 102188208 A 9/2011
 CN 103040412 A 4/2013
 CN 103040413 A 4/2013
 DE 875134 C 4/1953
 DE 3734355 C2 6/1989

(56)

References Cited

FOREIGN PATENT DOCUMENTS

DE	9216071	U1	2/1993
DE	4232382	C1	3/1994
DE	69907201	T2	2/2004
DE	60201666	T2	6/2006
DE	60033986	T2	11/2007
DE	112007003039	T5	10/2009
DE	112007003052	T5	1/2010
DE	202011003563	U1	5/2011
DE	112010001135	T5	8/2012
DE	202010018047	U1	11/2013
DE	202010018084	U1	2/2014
DE	202010018085	U1	2/2014
EP	489468	A1	6/1992
EP	1200196	B1	6/2005
EP	1674009	A2	6/2006
EP	1779761	A2	5/2007
EP	2471429	A3	11/2013
GB	700791	A	12/1953
GB	1111074	A	4/1968
GB	2163703	B	1/1988
GB	2282979	B	10/1997
JP	2000140533	A	5/2000
JP	2004121722	A	4/2004
JP	2005040246	A	2/2005
JP	2005087508	A	4/2005
JP	2009261501	A	11/2009
JP	2010081968	A	4/2010
JP	2010227287	A	10/2010
WO	8002561	A1	11/1980
WO	9400046	A1	1/1994
WO	9627446	A1	9/1996
WO	9809121	A1	3/1998
WO	9843721	A1	10/1998
WO	2007021043	A1	2/2007
WO	2006026414	A3	8/2007
WO	2008009890	A1	1/2008
WO	2007084699	A3	2/2008
WO	2008034325	A1	3/2008
WO	2009026709	A1	3/2009
WO	2009026714	A1	3/2009
WO	2009076774	A1	6/2009
WO	2010102396	A1	9/2010
WO	2010147247	A1	12/2010
WO	2011054106	A1	5/2011

OTHER PUBLICATIONS

English machine translation of DE202010018085U1 published on Feb. 27, 2014.

English machine translation of DE202010018084U1 published on Feb. 27, 2014.

English machine translation of De202010018047U1 published on Nov. 14, 2013.

English machine translation of DE112010001135T5 published on Aug. 2, 2012.

English machine translation of DE1120112007003052T5 published on Jan. 14, 2010.

English machine translation of DE112007003039T5 published on Oct. 29, 2009.

English machine translation of JP2010227287A published on Oct. 14, 2010.

English machine translation of JP2010081968A published on Apr. 15, 2010.

English machine translation of JP2009261501 published on Nov. 12, 2009.

English machine translation of JP2005087508 published on Apr. 7, 2005.

English machine translation of JP2005040246 published on Feb. 17, 2005.

English machine translation of JP2004121722 published on Apr. 22, 2004.

English machine translation of JP2000140533 published on May 23, 2000.

English machine translation of CN201290642 published on Aug. 19, 2009.

English machine translation of CN201101488 published on Aug. 20, 2008.

English machine translation of CN103040413 published on Apr. 17, 2013.

English machine translation of CN103040412 published on Apr. 17, 2013.

English machine translation of CN102188208 published on Sep. 21, 2011.

English machine translation of CN101657133 published on Feb. 24, 2010.

English machine translation of CN101357051 published on Feb. 4, 2009.

English machine translation of CN101073480 published on Nov. 21, 2007.

English machine translation of DE69907201 published on Feb. 5, 2004.

English machine translation DE60201666 published on Jun. 1, 2006.

English machine translation of DE60033986T2 published on Nov. 29, 2007.

English machine translation of DE9216071U1 published on Feb. 25, 1993.

English machine translation of DE4232382C1 published on Mar. 24, 1994.

English machine translation of DE3734355C2 published on Jun. 29, 1989.

English machine translation of CN2534954Y published on Feb. 12, 2003.

English machine translation of CN2524655Y published on Dec. 11, 2002.

English machine translation of CN1895148A published on Jan. 17, 2007.

English machine translation of CN1887437A published on Jan. 3, 2007.

English machine translation of CN1875855A published on Dec. 13, 2006.

English machine translation of CN1806741A published on Jul. 26, 2006.

English machine translation of CN1765283A published on May 3, 2006.

English machine translation of CN1506016A published on Jun. 23, 2004.

English machine translation of DE875134C published on Apr. 30, 1953.

International Search Report and Written Opinion, International Application No. PCT/CA2012/000185, dated Jun. 28, 2012.

Cheremisinoff, "Handbook of Air Pollution Prevention and Control", Butterworth-Heinemann, Elsevier Science (USA), 2002, pp. 397-404.

* cited by examiner

Figure 1

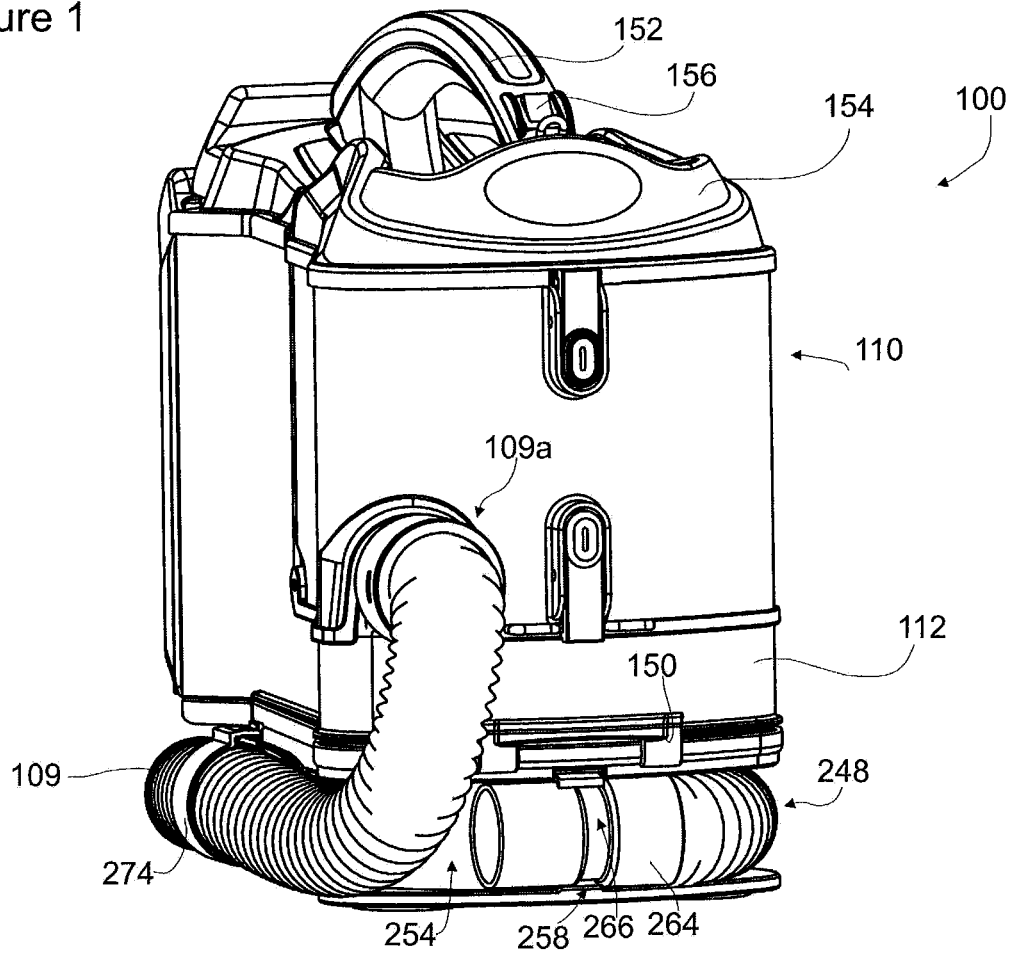

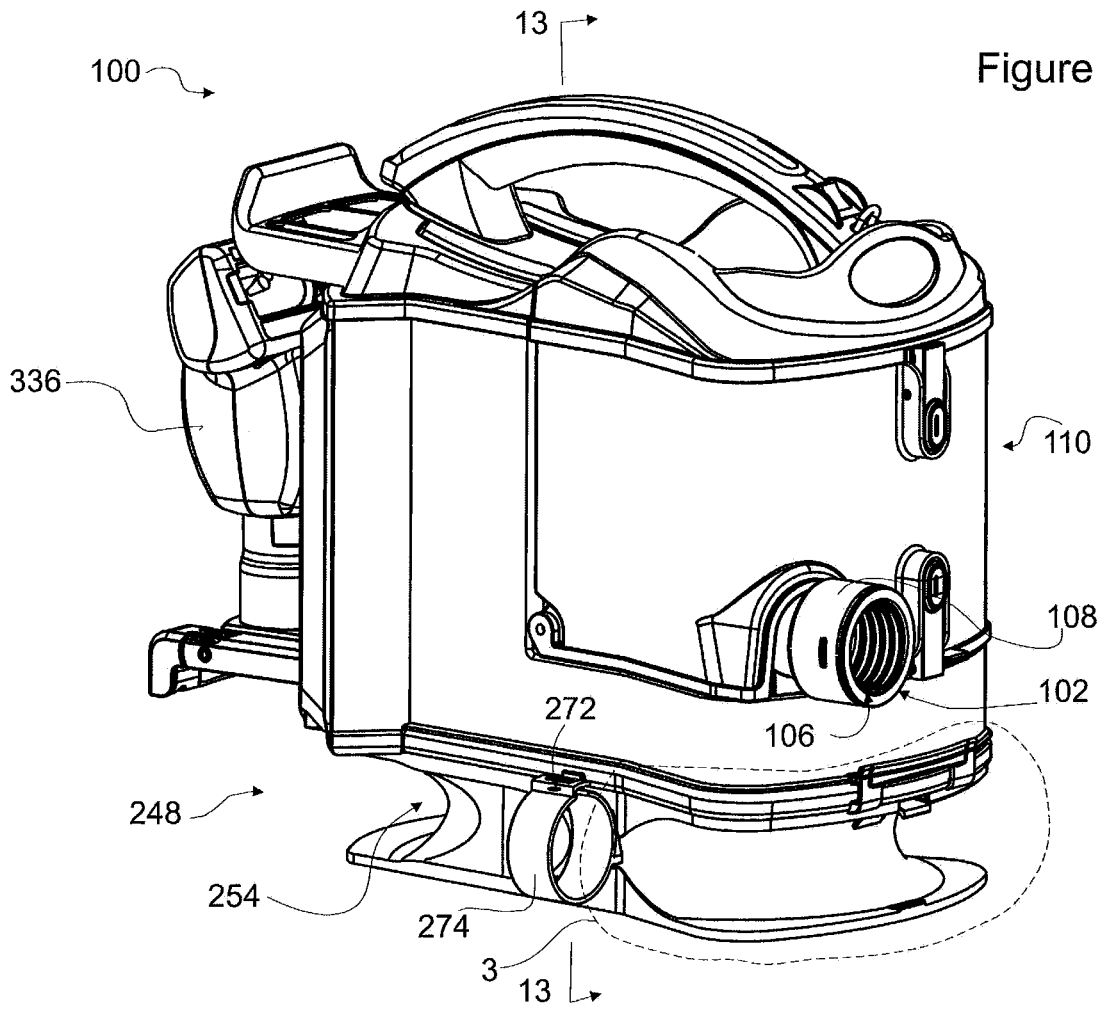
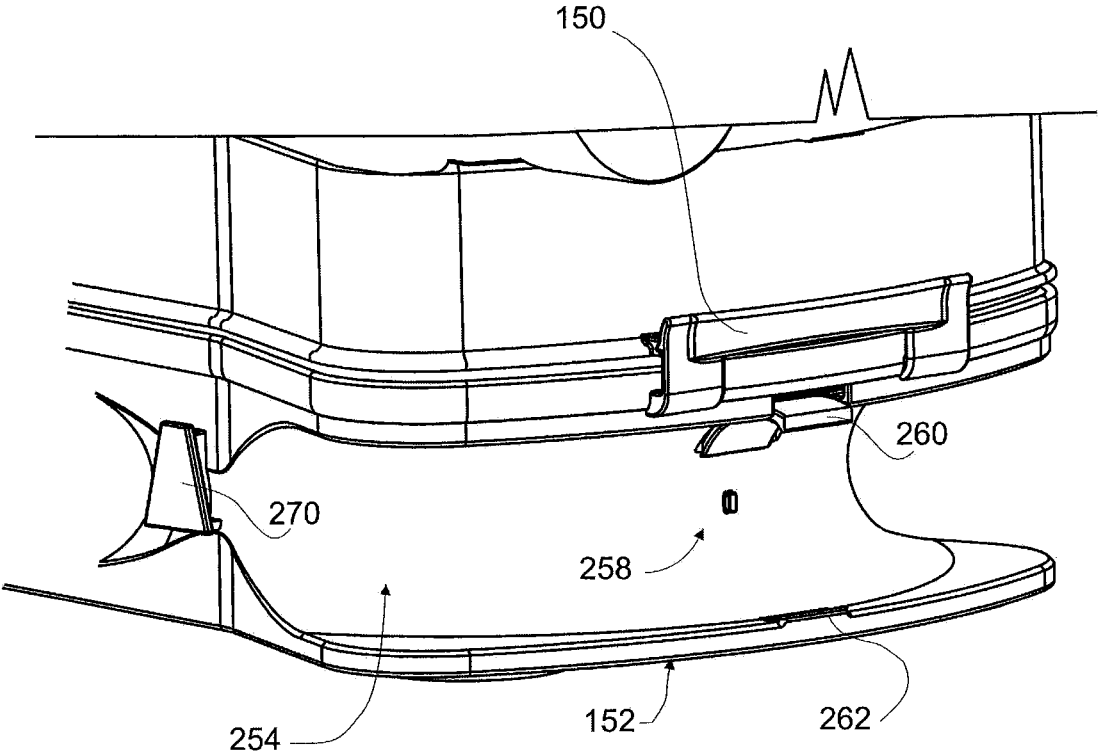

Figure 3



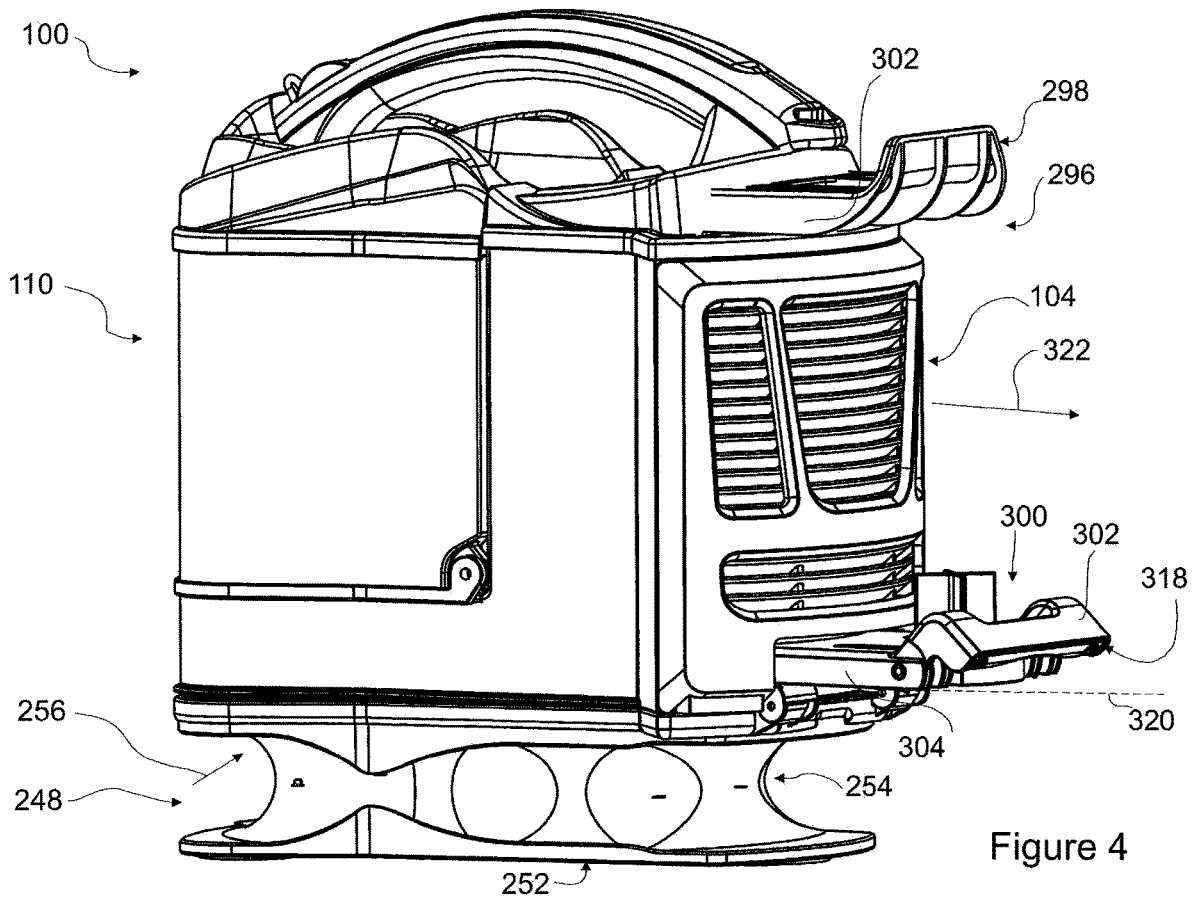

Figure 4

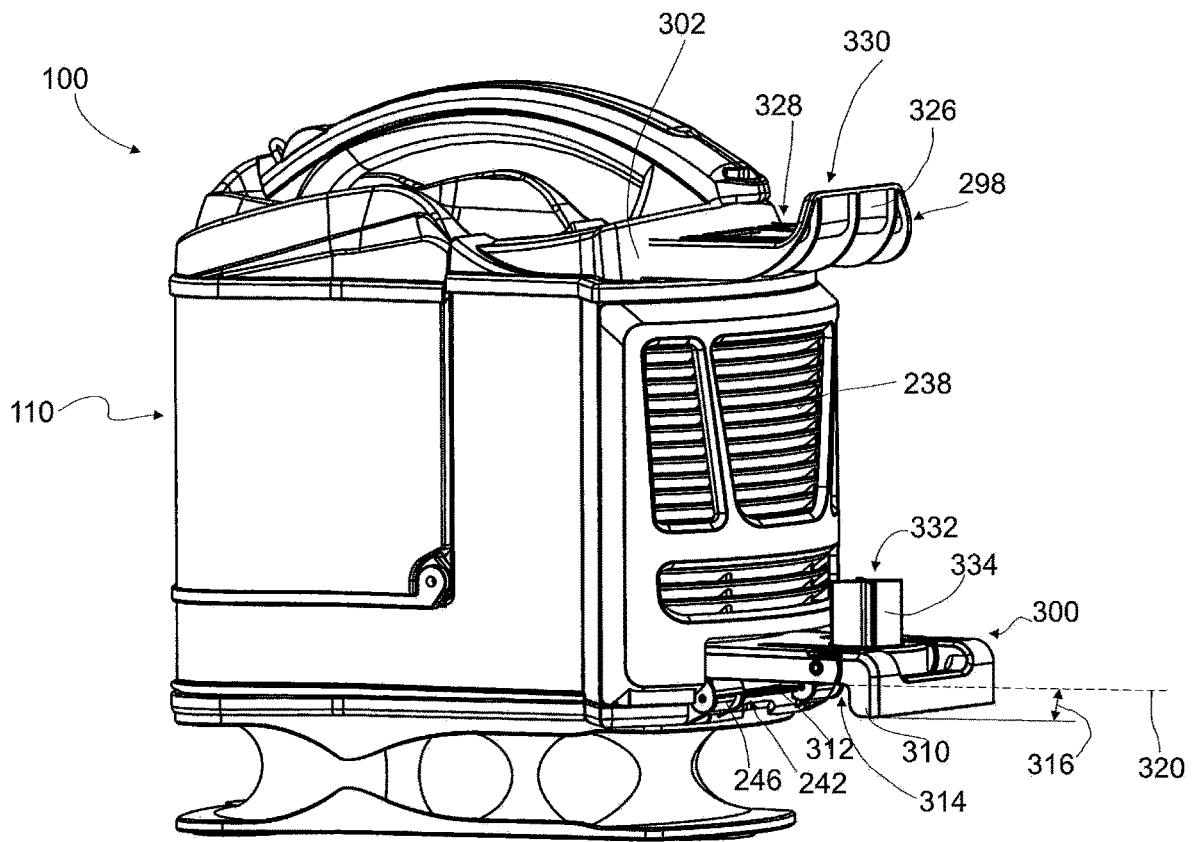

Figure 5

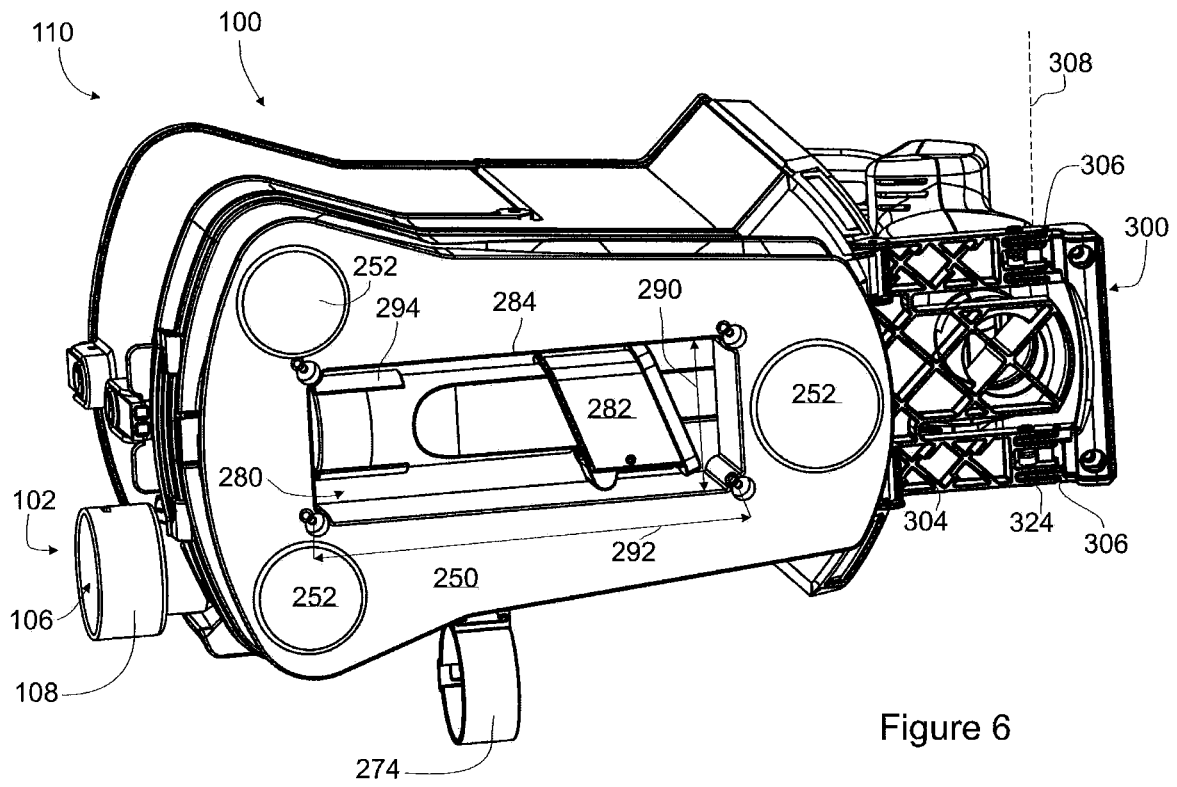

Figure 6

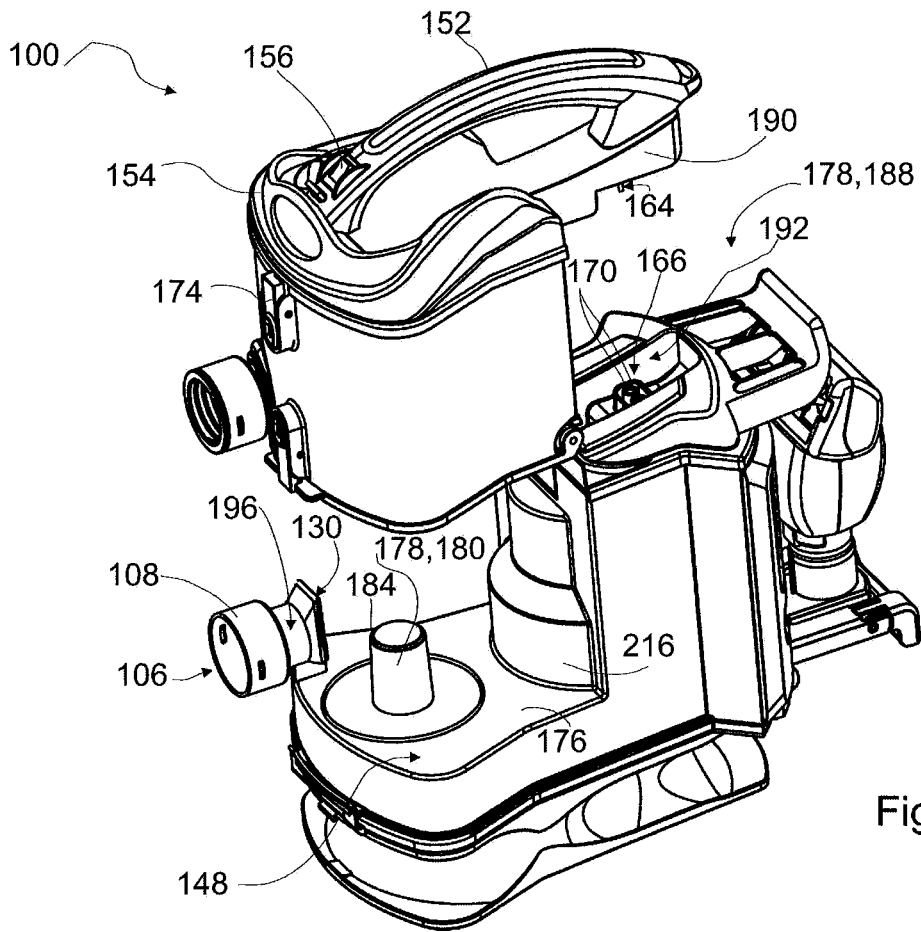
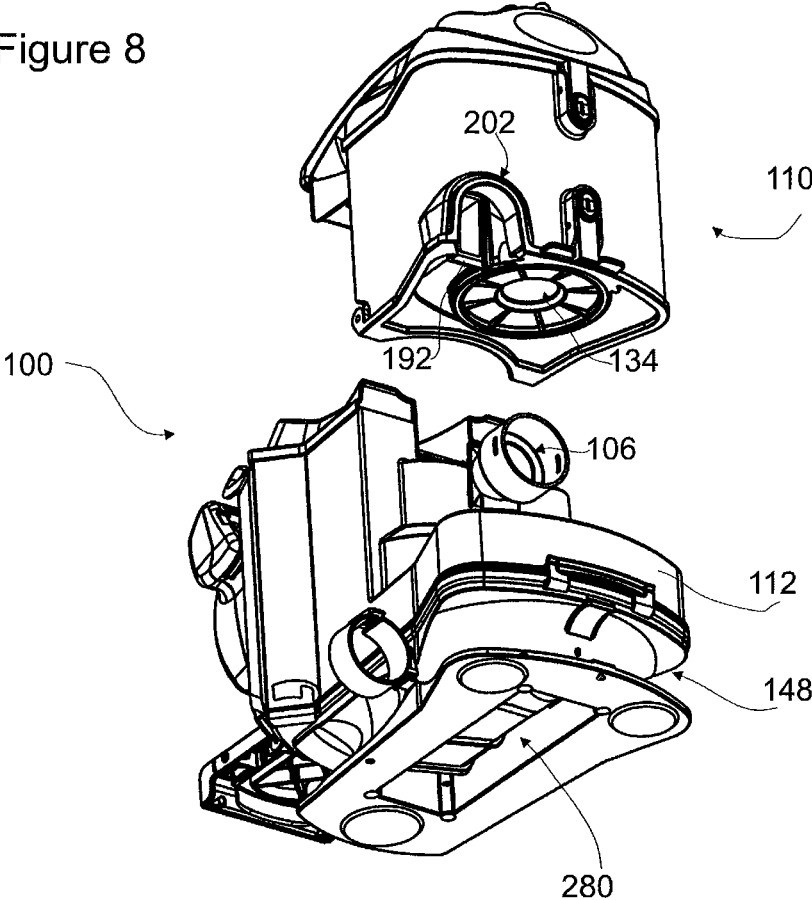

Figure 7

Figure 8



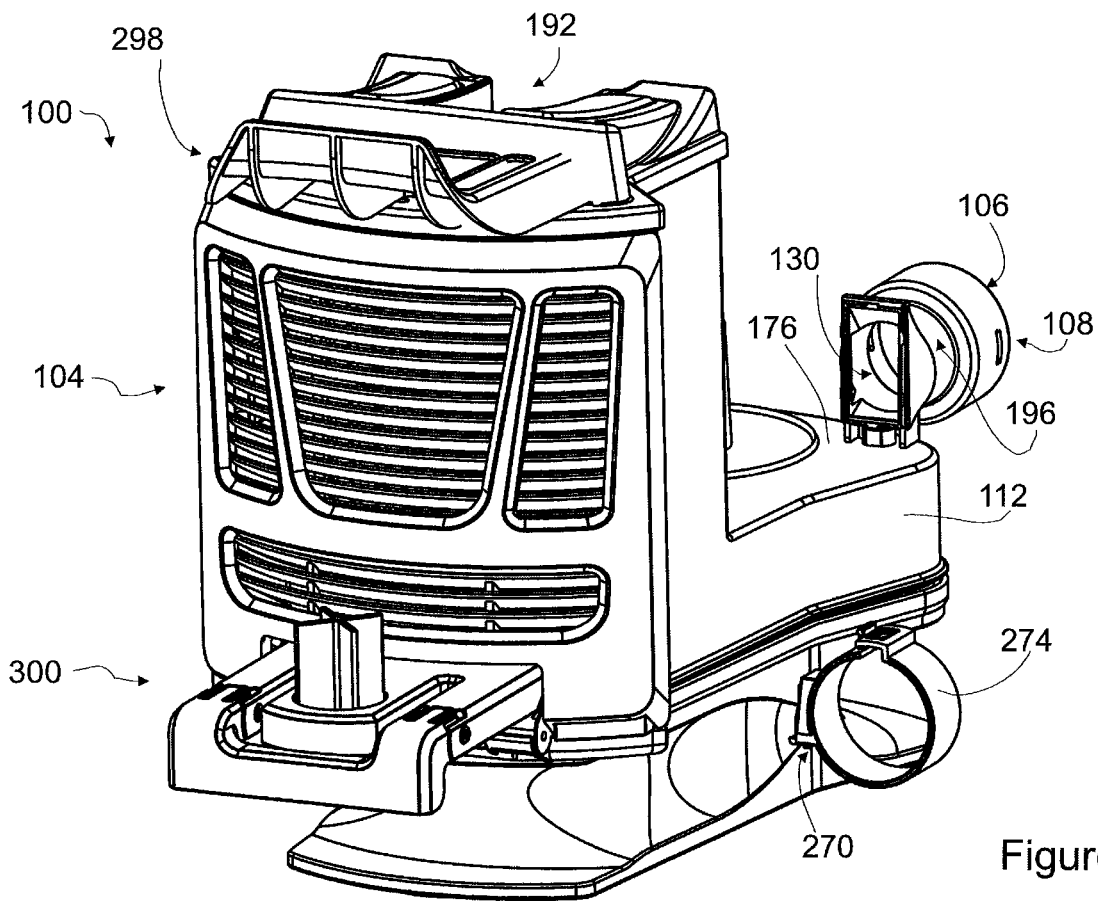

Figure 9

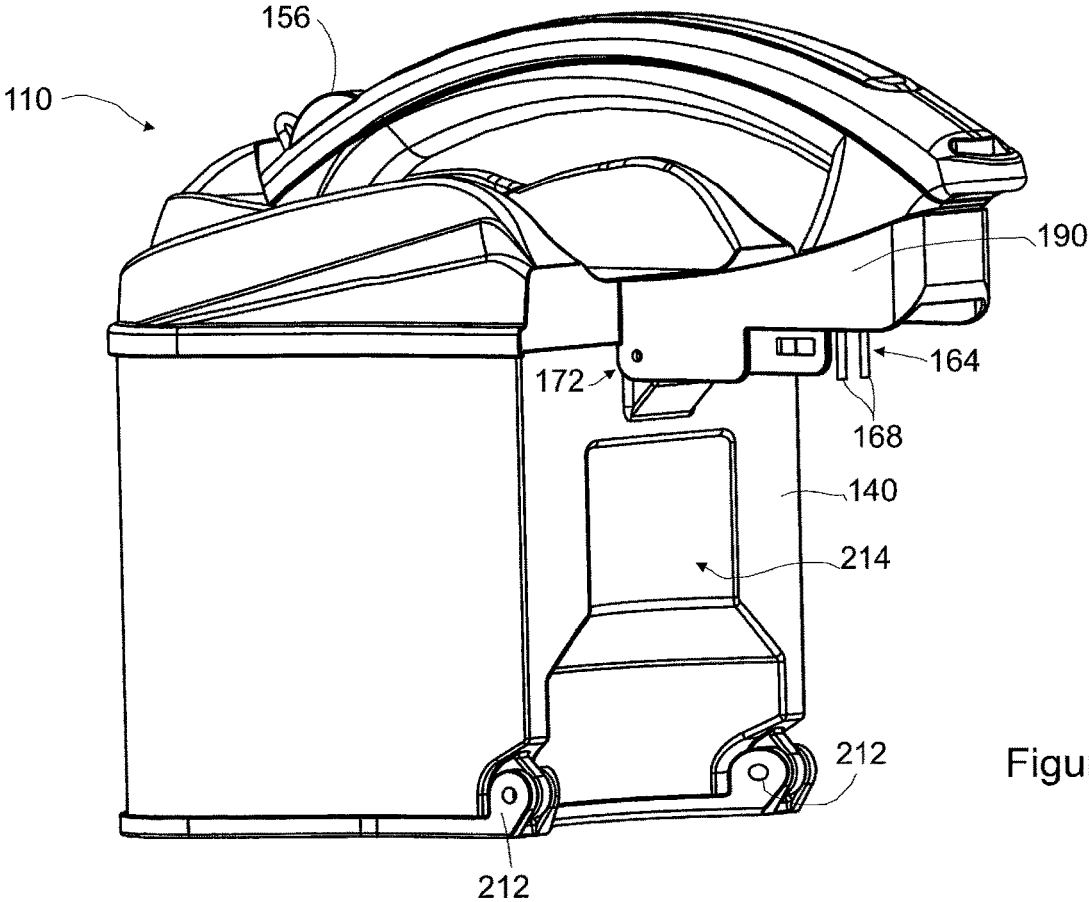

Figure 10

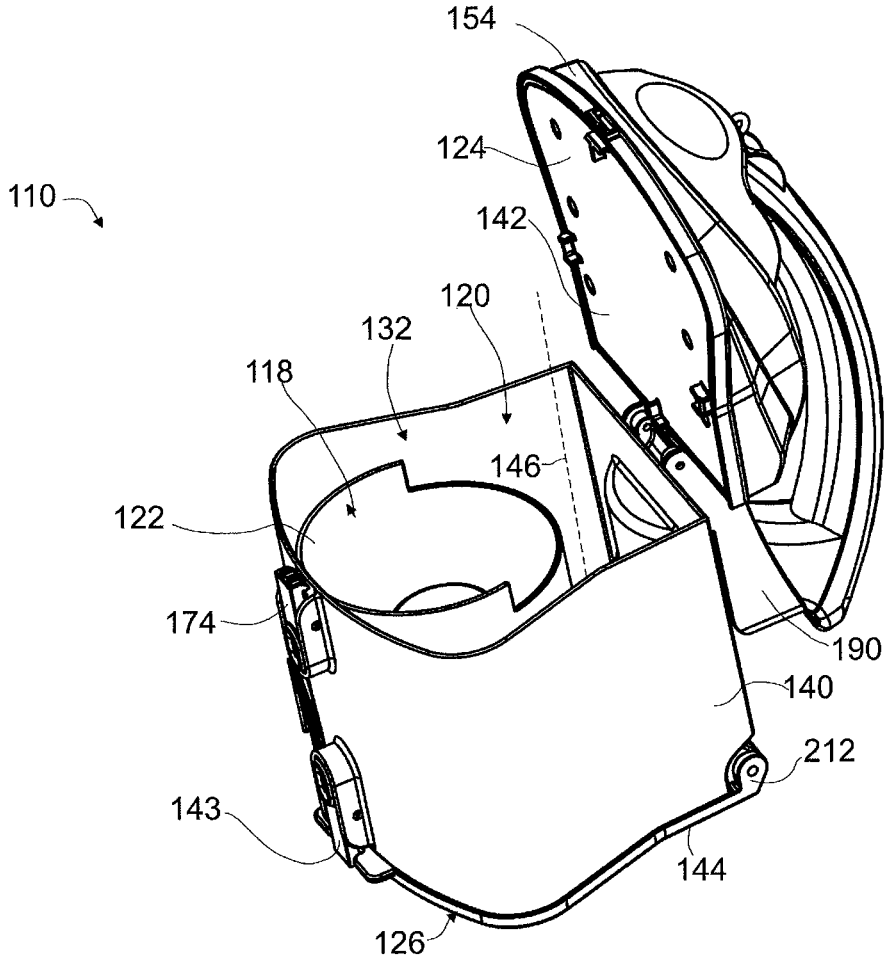

Figure 11

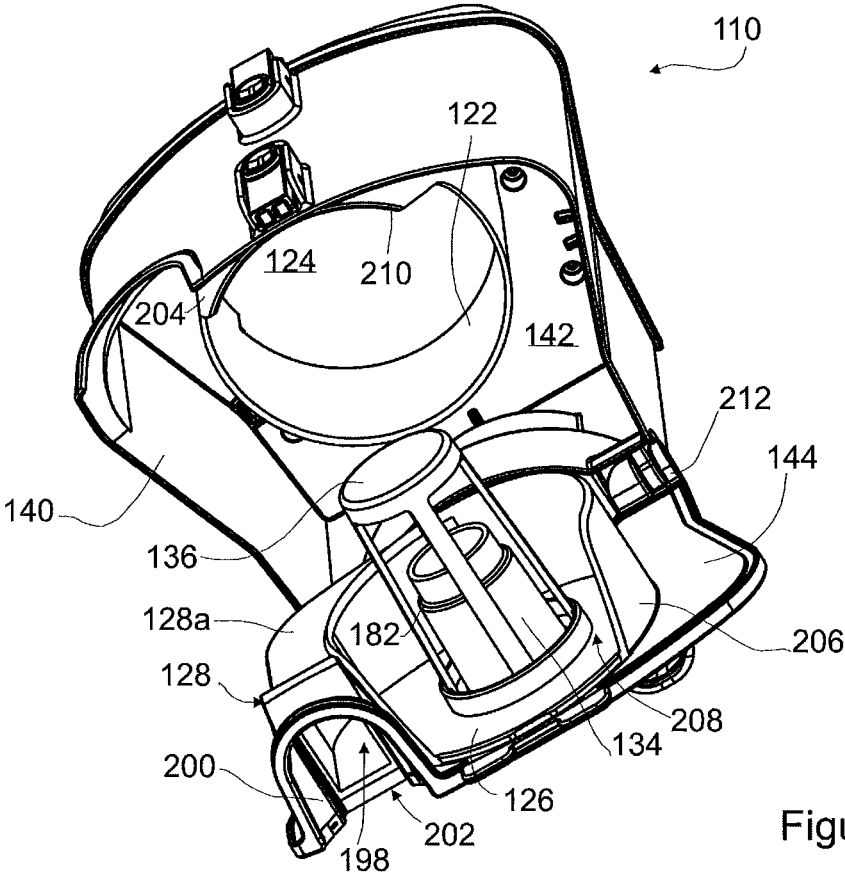
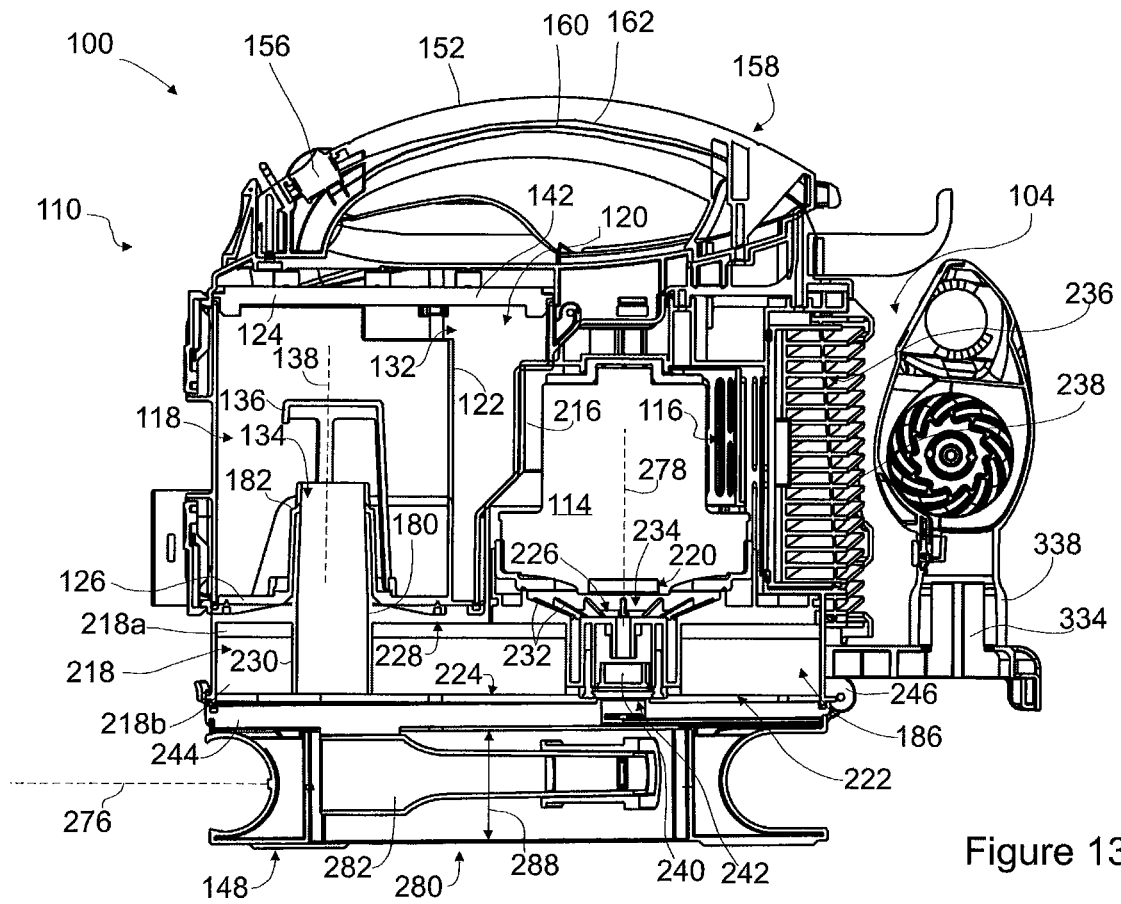

Figure 12



1

**PORTABLE SURFACE CLEANING
APPARATUS****CROSS REFERENCE TO RELATED
APPLICATION**

This application is a continuation of co-pending U.S. patent application Ser. No. 14/932,816, filed on Nov. 4, 2015, which is a continuation of U.S. patent application Ser. No. 13/040,676, filed on Mar. 4, 2011 and now U.S. Pat. No. 9,211,044, each of which is herein incorporated by reference in its entirety.

FIELD OF INVENTION

The disclosure relates to surface cleaning apparatuses, such as vacuum cleaners.

INTRODUCTION

Various constructions for surface cleaning apparatuses, such as vacuum cleaners, are known. Currently, many surface cleaning apparatuses are constructed using at least one cyclonic cleaning stage. Air is drawn into the vacuum cleaners through a dirty air inlet and conveyed to a cyclone inlet. The rotation of the air in the cyclone results in some of the particulate matter in the airflow stream being disentrained from the airflow stream. This material is then collected in a dirt bin collection chamber, which may be at the bottom of the cyclone or in a direct collection chamber exterior to the cyclone chamber (see for example WO2009/026709 and U.S. Pat. No. 5,078,761). One or more additional cyclonic cleaning stages and/or filters may be positioned downstream from the cyclone.

SUMMARY OF THE INVENTION

The following summary is provided to introduce the reader to the more detailed discussion to follow. The summary is not intended to limit or define the claims.

According to one broad aspect, a surface cleaning apparatus has a main body with a removable air treatment member, which preferably comprises a cyclone bin assembly, comprising a cyclone chamber and a dirt collection chamber. The surface cleaning apparatus also has a suction hose connector to which a flexible suction hose may be connected, and optionally releasably connected. The downstream side of the suction hose connector is in fluid communication with the cyclone chamber.

Preferably, the suction hose connector is fixedly connected to the main body, so that the suction hose connector remains connected to the body when the cyclone bin assembly is removed. An advantage of this configuration may be that it allows the cyclone bin assembly to be separated from the suction hose connector, and the associated suction hose, when the cyclone bin assembly is detached from the body. This may allow a user to manipulate the cyclone bin assembly without also having to handle the flexible suction hose.

Preferably, at least a portion of the suction hose connector is nested within the cyclone bin assembly. For example, the downstream end of the suction hose connector can be nested within the dirt collection chamber. An advantage of this configuration may be that the overall size of the surface cleaning apparatus may be reduced. Further, the suction hose connector may be protected or partially protected from impact.

2

Preferably, the downstream side of the suction hose connector is connectable to a tangential air inlet of the cyclone chamber. More preferably, the tangential air inlet is automatically connected to the suction hose connector when the cyclone bin assembly is placed on the main body.

In accordance with this broad aspect, a surface cleaning apparatus comprises an air flow path extending from a dirty air inlet to a clean air outlet. The surface cleaning apparatus may also comprise a main body comprising a suction motor provided in the air flow path. A cyclone bin assembly may be provided in the air flow path and may be removably mounted to the main body. The cyclone bin assembly may comprise a cyclone chamber. A hose connector may be provided on the main body. The hose connector may comprise a portion of the air flow path from the dirty air inlet to the cyclone bin assembly.

The hose connector may be nested in the cyclone bin assembly when the cyclone bin assembly is mounted to the main body.

The hose connector may be in line with a tangential inlet of the cyclone chamber.

The cyclone bin assembly may comprise a dirt collection chamber and the hose connector may be nested in the dirt collection chamber.

The main body may comprise a platform on which the cyclone bin assembly is removably mounted. The hose connector may be provided on the platform.

The hose connector may be fixedly provided on the platform.

The cyclone bin assembly may have a recess for removably receiving the hose connector.

The recess may be provided in a lower surface of the cyclone bin assembly.

The hose connector may be slidably receivable in the recess.

The cyclone bin assembly is mountable on the main body upon movement in a particular direction. The hose connector may have a flange at an air outlet end of the hose connector and the flange may be sealingly mateable with a wall extending in the particular direction.

The surface cleaning apparatus may comprise a flexible suction hose extending between a cleaning head or cleaning tool and the hose connector.

The surface cleaning apparatus may be a portable surface cleaning apparatus.

The cyclone bin assembly further may comprise a handle for the surface cleaning apparatus.

In accordance with this broad aspect, a surface cleaning apparatus may alternately comprise an air flow path extending from a dirty air inlet to a clean air outlet. The surface cleaning apparatus may also comprise a main body comprising a suction motor provided in the air flow path. A cyclone bin assembly may be provided in the air flow path and may be removably mounted to the main body. The cyclone bin assembly may comprise a cyclone chamber. The hose connector may comprise a portion of the air flow path from the dirty air inlet to the cyclone bin assembly wherein the hose connector is nested in the cyclone bin assembly.

The hose connector may be in line with a tangential inlet of the cyclone chamber.

The main body may comprise a platform on which the cyclone bin assembly is removably mounted.

The cyclone bin assembly may have a recess provided in a lower surface of the cyclone bin assembly in which the hose connector is mounted.

The surface cleaning apparatus may be a portable surface cleaning apparatus and, preferably, the cyclone bin assembly further comprises a handle for the surface cleaning apparatus.

DRAWINGS

Reference is made in the detailed description to the accompanying drawings, in which:

FIG. 1 is a perspective view of an example of a surface cleaning apparatus;

FIG. 2 is a perspective view of the surface cleaning apparatus shown in FIG. 1, with a suction hose removed;

FIG. 3 is an enlarged view of a base portion of the surface cleaning apparatus of FIG. 2;

FIG. 4 is a side view of the side of the surface cleaning apparatus shown in FIG. 2, with a cord retainer in a cord removal position;

FIG. 5 is a rear perspective view of the surface cleaning apparatus of FIG. 2, with a cord retainer in a cord retaining position;

FIG. 6 is a bottom perspective view of the surface cleaning apparatus of FIG. 2;

FIG. 7 is a top perspective view of the surface cleaning apparatus of FIG. 2, with a cyclone bin assembly separated from the body;

FIG. 8 is a bottom perspective view of the surface cleaning apparatus of FIG. 7;

FIG. 9 is a rear perspective view of the surface cleaning apparatus of FIG. 1, with the cyclone bin assembly removed;

FIG. 10 is a rear perspective view of the cyclone bin assembly;

FIG. 11 is top perspective view of the cyclone bin assembly of FIG. 10, with the lid in an open position;

FIG. 12 is a lower perspective view of the cyclone bin assembly of FIG. 10, with the dirt collection chamber end wall in an open position; and,

FIG. 13 is a section view of the surface cleaning apparatus of FIG. 2, taken along line 13-13.

DETAILED DESCRIPTION

Referring to FIG. 1, an embodiment of a surface cleaning apparatus 100 is shown. In the embodiment illustrated, the surface cleaning apparatus 100 is a hand operable surface cleaning apparatus. In alternate embodiments, the surface cleaning apparatus may be another suitable type of surface cleaning apparatus, including, for example, an upright vacuum cleaner, a canister vacuum cleaner, a stick vac, a wet-dry vacuum cleaner and a carpet extractor. Power can be supplied to the surface cleaning apparatus 100 by an electrical cord (not shown) that can be connected to a standard wall electrical outlet. Alternatively, or in addition, the power source for the surface cleaning apparatus can be an onboard power source, including, for example, one or more batteries. General Overview

Referring to FIGS. 1 and 2, the surface cleaning apparatus 100 has a dirty air inlet 102, a clean air outlet 104 (see for example FIGS. 4 and 13) and an airflow passage extending therebetween. In the embodiment shown, the dirty air inlet 102 is the air inlet 106 of a suction hose connector 108 that can be connected to the downstream end 109a of a flexible suction hose 109 or other type of cleaning accessory tool, including, for example, a wand and a nozzle. From the dirty air inlet 102, the airflow passage extends through an air treatment member that can treat the air in a desired manner, including for example removing dirt particles and debris

from the air. In the illustrated example, the air treatment member comprises a cyclone bin assembly 110. The cyclone bin assembly 110 is mounted on a main body 112. Alternatively, the air treatment member can comprise a bag, a filter or other air treating means. A suction motor 114 (FIG. 13) is mounted within the body 112 and is in fluid communication with the cyclone bin assembly 110.

Referring to FIG. 13, the clean air outlet 104, which is in fluid communication with an outlet 116 of the suction motor 114, is provided in the body 112. In the illustrated example, the dirty air inlet 102 is located toward the front of the surface cleaning apparatus 100, and the clear air outlet 104 is located toward the rear.

Cyclone Bin Assembly

Referring to FIGS. 10-13, in the illustrated example, cyclone bin assembly 110 includes a cyclone chamber 118 and a dirt collection chamber 120. The cyclone chamber 118 is bounded by a sidewall 122, a first end wall 124 and a second end wall 126 that are configured to preferably provide an inverted cyclone configuration. A tangential air inlet 128 is provided in the sidewall of the cyclone chamber 118 and is in fluid communication with the air outlet 130 (FIG. 9) of the hose connector 108. Air flowing into the cyclone chamber 118 via the air inlet 128 can circulate around the interior of the cyclone chamber 118 and dirt particles and other debris can become disentrained from the circulating air. It will be appreciated that the cyclone chamber may be of any configuration and that one or more cyclone chambers may be utilized. In the example illustrated the cyclone bin assembly 110, and the cyclone chamber 118 are arranged in a generally vertical, inverted cyclone configuration. Alternatively, the cyclone bin assembly 110 and cyclone chamber 118 can be provided in another orientation, including, for example, as a horizontal cyclone.

Cyclone chamber 118 may be in communication with a dirt collection chamber 120 by any means known in the art. Preferably, as exemplified, the dirt collection chamber 120 is exterior to cyclone chamber 118, and preferably at least partially surrounds and, more preferably completely surrounds, cyclone chamber 118. Accordingly, cyclone chamber 118 is in communication with dirt collection chamber 118 via a dirt outlet 132. Preferably, the dirt outlet 132 comprises a slot 132 formed between the sidewall 122 and the first end wall 124. Slot 124 comprises a gap between an upper portion of cyclone chamber sidewall 122 and the lower surface of first end wall 124. Preferably, the gap extends only part way around sidewall 122. Debris separated from the air flow in the cyclone chamber 118 can travel from the cyclone chamber 118, through the dirt outlet 132 to the dirt collection chamber 120.

Air can exit the cyclone chamber 118 via an air outlet 134. In the illustrated example, the cyclone air outlet includes a vortex finder 134. Optionally, a removable screen 136 can be positioned over the vortex finder 134. The cyclone chamber 118 extends along a longitudinal cyclone axis 138 (FIG. 13). In the example illustrated, the longitudinal cyclone axis 138 is aligned with the orientation of the vortex finder 134.

The dirt collection chamber 120 comprises a sidewall 140, a first end wall 142 and an opposing second end wall 144. In the illustrated example, at least a portion of the dirt collection chamber sidewall 140 is integral with a portion of the cyclone chamber sidewall 122, at least a portion of the first cyclone end wall 124 is integral with a portion of the first dirt collection chamber end wall 142 and/or and at least a portion of the second cyclone end wall 126 is integral with a portion of the second dirt collection chamber end wall 144. The dirt collection chamber 120 extends along a dirt col-

lection axis **146** (FIG. **146**). Optionally, the dirt collection axis **146** can be parallel to and offset from the cyclone axis **138**.

The dirt collection chamber **120** may be emptyable by any means known in the art and is preferably openable concurrently with the cyclone chamber **118**. Preferably, the second dirt collection chamber end wall **142** is pivotally connected to, e.g., the dirt collection chamber sidewall **140**, such as by hinges **212**. The second dirt collection chamber end wall **144** can be opened (FIG. **12**) to empty dirt and debris from the interior of the dirt collection chamber **120**. In the illustrated example, the second cyclone end wall **126** is integral with, and is openable with, the second dirt collection chamber end wall **144**. Accordingly, opening the second cyclone end wall **126** can allow dirt and debris to be emptied from the cyclone chamber **118** and the dirt collection chamber **120**. The second dirt collection chamber end wall **144** can be retained in the closed position by any means known in the art, such as by a releasable latch **143**.

Alternately, or in addition, as shown in the illustrated example, the first cyclone end wall **124** may be integral with, and is openable with, the first dirt collection chamber end wall **142**. Accordingly, opening the first cyclone end wall **124** can allow dirt and debris to be emptied from the cyclone chamber **118** and the dirt collection chamber **120**. The first dirt collection chamber end wall **142** can be retained in the closed position by any means known in the art, such as by a releasable latch.

A handle **152** is provided on the top of the cyclone bin assembly **110**. The handle **152** is configured to be grasped by a user. When the cyclone bin assembly **110** is mounted on the body **112**, the handle **152** can be used to manipulate the surface cleaning apparatus **100**. When the cyclone bin assembly **110** is removed from the body **112**, the handle **152** can be used to carry the cyclone bin assembly **110**, for example to position the cyclone bin assembly **110** above a waste receptacle for emptying. In the illustrated example, the handle **152** is integral with a lid **154** of the cyclone bin assembly **110**.

Securing the Cyclone Bin Assembly on the Main Body

Referring to FIGS. **7** and **8**, optionally, the cyclone bin assembly **110** is detachably connected to the body **112**. Preferably, as exemplified, the cyclone bin assembly **110** is detachably mounted on a platform **148**. One or more releasable latches may be used to secure cyclone bin assembly **110** to main body **112**. As exemplified, the rear surface of the cyclone bin assembly **110** abuts against the front wall of the suction motor housing **216** of the main body **112**. Accordingly, a single releasable latch **150** (see for example FIG. **2**) can be used to secure a front edge of the cyclone bin assembly **110** to the body **112** and thereby secure the cyclone bin assembly **110** to the main body **112**. Alternately, two or more securing members may be provided.

Removable Main Power Switch

Referring to FIGS. **7**, **8** and **13**, a main power switch **156** for the surface cleaning apparatus **100** (e.g. for controlling the operation of the suction motor **114**) is removable with cyclone bin assembly **110** and is preferably provided on the lid **154** of the cyclone bin assembly **110**. The power switch **156** is connected to the suction motor **114** by a control circuit **158**, and is operable to control the supply of power from a power source to the suction motor **114**. Preferably, the power switch **156** is positioned in close proximity to the handle **152**. Providing the power switch **156** close to, or optionally on, the handle **154** may help allow a user to operate the power switch **156** with the same hand that used to grasp the handle **154**.

Control circuit **158** may be of various designs which include main power switch **156** and enable main power switch **156** to be used to selectively actuate the suction motor **114**. As exemplified in FIG. **13**, the control circuit **158** comprises electrical conduits, for example wires **160**, which can be provided internally in cyclone bin assembly **110** (e.g., in an internal handle conduit **162**). The plurality of wires **160** can electrically connect the switch **156** to a power source in the body **112** and/or the suction motor **114**.

Referring to FIGS. **7** and **10**, optionally, the control circuit **158** between the power switch **154** and the suction motor **114** comprises a decoupling member and is interruptible, and the power switch **158** can be detachable from the body **112**. In the illustrated example, the decoupling member comprises first and second power connectors **164**, **166**. The lid **154** of the cyclone bin assembly **110** comprises a first power connector **164** and the body **112** comprises a second, mating power connector **166**. When the cyclone bin assembly **110** is mounted on the body **112**, the first power connector **164** is electrically coupled to the second power connector **166**. Connecting the first and second power connectors **164**, **166** can complete an electrical control circuit **158** between the power switch **156** and the suction motor **114** such that main power switch **156** may control the actuation of the suction motor. The first and second power connectors **164**, **166** are releasably coupled and can be separated from each other to interrupt the electrical connection between the power switch **156** and the suction motor **114**. In the illustrated example, separating the cyclone bin assembly **110** from the body **112** automatically separates the first and second power connectors **164**, **166**.

In the illustrated example the first power connector **164** is a male power connector, comprising two prongs **168**, and the second power connector **166** is a female power connector comprising a two corresponding receptacles **170** to receive the prongs **168**. Accordingly, the second power connector **166** can remain connected to a power supply when the cyclone bin assembly **110** is removed. Providing a female power connector **166** on the body **112**, instead of a pair of exposed prongs **168**, may help reduce the risk of electric shock to a user when the cyclone bin assembly **110** is removed, and the second power connector **166** is exposed.

Alternatively, instead of providing a continuous electrical connection between the power switch **156** and the suction motor **114**, the connection between cyclone bin assembly **110** and the body **112** can be another type of control system. For example, instead of providing electrical wires **160** in the handle conduit **162**, the control circuit **158** can comprise an electrical circuit housed in the main body that is interruptible by movement of main power switch, e.g., with the cyclone bin assembly **110**, away from an in use position on main body **112**. For example, a mechanical linkage system may be used. The mechanical linkage system (e.g., an abutment member such as a post) can be configured to translate movements of the power switch **156** to open and close a circuit in the main body. For example, the post may be driving connected to a relay positioned on the body **112** and that forms part of the circuit. The relay can then convert the movements of the mechanical linkage into electrical signals, optionally via onboard electronics, to control the suction motor **114**. For example, removing the cyclone bin assembly **110** from the body **112** would move the post out of engagement with the relay thereby permitting the relay to open the circuit.

In another example, the power switch **156** may be connected to an RF (or other type of wireless transmitter) in the cyclone bin assembly **110**, and the body **112** can include an

RF receiver that can control the operation of the suction motor **114** (or vice versa). The surface cleaning apparatus **100** can also include a proximity sensor configured to sense whether the cyclone bin assembly **118** is mounted on the body **112**. In this example, moving the power switch **156** may generate a wireless control signal that is received by the RF receiver. The proximity sensor can be communicably linked to at least one of the RF transmitter or RF receiver and can be configured to deactivate at least one of the RF transmitter or RF receiver when the cyclone bin assembly **110** is removed from the base. Alternately, the proximity sensor could be drivingly connected to a relay or the like to close the relay when the cyclone bin assembly is mounted to main body **112**. For example, the proximity sensor could be provided in main body **12** and could be actuated by a magnet provided at a suitable location in cyclone bin assembly **110**.

Optionally, the lid **154** need not be attached to cyclone bin assembly **110**. Instead, lid **154** may be moveably mounted on main body **12**, or removable therefrom, to permit cyclone bin assembly **110** to be removed. As exemplified in FIGS. **10** and **11**, the lid **154** may be pivotally mounted to main body **12** by a hinge **172** and moveable between an open position (FIG. **11**) wherein the cyclone bin assembly **110** may be removed and a closed position (FIG. **10**) wherein the cyclone bin assembly is secured in position. In the illustrated example, the hinge **172** is provided toward the rear of the cyclone bin assembly **110**. The lid **154** may be releasably retained in the closed position by any means, such as a latch **174** provided toward the front of the cyclone bin assembly **110**. Opening the lid **154** may allow a user to access the interior of the dirt collection chamber **120** and cyclone chamber **118**. Optionally, the screen **136** and/or the vortex finder **134** can be removable from the cyclone chamber **118** and can be removed via the top of the cyclone bin assembly **110** when the lid **154** is opened.

Alignment Members for Locating and Orienting the Cyclone Bin Assembly

Referring again to FIGS. **7-9** and **13**, the platform **148** may comprise a generally planar bearing surface **176** for supporting the cyclone bin assembly **110**. Optionally, the main body may comprise at least one alignment member configured to engage the cyclone bin assembly **110** and thereby align and/or orient the cyclone bin assembly for mounting on main body **12**. Preferably at least one of the alignment members is provided on the platform **148**. Providing at least one alignment member **178** may help a user to replace the cyclone bin assembly **110** on the platform **148** in a desired, operating position.

In the illustrated, the at least one alignment member **178** comprises a vortex finder insert **180** extending from the platform **148**. The vortex finder insert **180** is a hollow conduit and is configured to fit within the vortex finder **134** in the cyclone bin assembly **110**. In this configuration, the vortex finder insert **180** can comprise a portion of the air outlet of the cyclone chamber **118**, and can comprise a portion of the air flow path between the dirty air inlet **102** and the clean air outlet **104**.

Optionally, the vortex finder **134** can include an annular mounting shoulder **182** that is configured to rest on the upper face **184** of the vortex finder insert **180** (see also FIG. **12**). With the cyclone bin assembly **110** seated on the platform **148**, and the insert **180** received in the vortex finder **134**, air exiting the cyclone chamber **118** can flow through both the vortex finder **134** and vortex finder insert **180** and into a filter chamber **186** in the body **112**.

In the illustrated example, both the vortex finder **134** and vortex finder insert **180** have a circular cross sectional shape.

Locating the vortex finder insert **180** within the vortex finder **134** can provide lateral alignment and front/back alignment of the cyclone bin assembly **110** on the platform **148**, but may still allow relative rotation between the cyclone bin assembly **110** and the body **112**.

Optionally, an engagement member can be provided to help retain the vortex finder insert **180** within the vortex finder **134**. For example, a detent connection can be provided between the vortex finder insert **180** and the vortex finder **134** to help retain the vortex finder **134** on the insert **180**.

Optionally, the cyclone bin assembly **110** can be configured so that vortex finder insert **180** serves as the vortex finder **134** in the cyclone chamber **118**. In this configuration, vortex finder insert **180** may be removable received in the cyclone chamber **118**. For example, the second cyclone endwall **126** may comprise an aperture that is sized to receive the vortex finder insert **180** and to create a generally air tight seal. With the cyclone bin assembly **110** seated on the platform **148**, the vortex finder insert **180** is inserted into cyclone chamber **118** and may then serve as the vortex finder within the cyclone chamber **118**. When the cyclone bin assembly **110** is removed, the vortex finder insert **180** is removed from cyclone chamber **118** and no vortex finder remains in cyclone chamber **118**. Optionally, a relatively short annular lip can be provided around the perimeter of the aperture. The inner surface of the lip can rest against the outer surfaces of the vortex finder insert **180** and may help seal the cyclone chamber **118**. The lip and/or vortex finder insert **180** can each be tapered, and optionally can be configured as a morse taper to help seal the cyclone chamber **118**. Alternatively, the body **112** may not include a vortex finder insert **180**, and the outlet of the vortex finder **134** can be sealed against an air inlet aperture in the platform **148**.

Referring to FIGS. **7-10**, optionally, the at least one alignment member **178** can also include at least one rotational alignment member **188**. The rotational alignment member may be utilized to orient the cyclone bin assembly on main body **12**. In the illustrated example, a tongue **190** extending from the rear of the cyclone bin assembly lid **154** can cooperate with a corresponding slot **192** in the body **112** to serve as a rotational alignment member **188**. The slot **192** is sized and shaped to receive the tongue **190** in one desired alignment. When the tongue **190** is positioned within the slot **192** the cyclone bin assembly **110** is provided in the desired, operating and mounting orientation. The interaction between the tongue **190** and the slot **192** may also help provide lateral and front/back alignment of the cyclone bin assembly **110**. Preferably, as exemplified, the first power connector **164** is provided on the underside of the tongue **190**, and the second power connector **166** is provided within the slot **192**.

Suction Hose Connector

Preferably, the suction hose connector **108** is mounted to the main body **112** so as to remain in position when the cyclone bin assembly **110** is removed. Alternately, or in addition, the hose connector **108** is nested or recessed into the cyclone bin assembly **110**.

As exemplified, preferably the suction hose connector **108** is connected to the platform **148**, and remains connected to the platform **148** when the cyclone bin assembly **110** is removed. The suction hose connector **108** comprises an air inlet **106** that may be connectable to a suction hose and is in communication with the opposing air outlet **130**. A throat portion **196** of the suction hose connector **108** optionally extends between the air inlet **106** and air outlet **130**. Coupling the suction hose connector **108** to the body **112** may help facilitate the removal of the cyclone bin assembly **110**

(for example to empty the dirt collection chamber 120) while leaving the suction hose connected to the body 112, via the suction hose connector 108.

The air outlet 130 is configured to connect to the tangential air inlet 128 of the cyclone chamber 118. Referring to FIGS. 8 and 12, in the illustrated example, a sealing face 198 on the tangential air inlet 128 is shaped to match the shape and orientation of the air outlet 130 of the suction hose connector 108. Optionally, a gasket 200, or other type of sealing member, can be provided at the interface between the sealing face 198 and the air outlet 130.

The air outlet 130 of the suction hose connector 108 and the sealing face 198 of the tangential air inlet 128 may preferably be configured so that the sealing face 198 can slide relative to the air outlet 130 (vertically in the illustrated example) as the cyclone bin assembly 110 is being placed on, or lifted off of, the platform 148. As the cyclone bin assembly 110 is lowered onto the platform 148, the sealing face 198 may slide into a sealing position relative to the air outlet 130. In the sealing position, the gasket 200 is preferably aligned with the walls of the air outlet 130.

Optionally, part or all of hose connector 108 is recessed or nested within cyclone bin assembly 110. An advantage of this design is that the length of the surface cleaning apparatus may be reduced. A further advantage is that the hose connector 108 may be protected from impact during use.

Accordingly, the sealing face 198 may be recessed within the cyclone bin assembly 110. In the illustrated example, the cyclone bin assembly 110 includes a notch 202 in a lower surface that is configured to receive the throat portion 196 of the suction hose connector 108 when the cyclone bin assembly 110 is placed on the platform 148. With the cyclone bin assembly 110 on the platform 148, at least a portion of the throat 196 and the air outlet 130 are nested within cyclone bin assembly 110, which can help seal the air outlet 130 with the sealing face 198.

It will be appreciated that by nesting the hose connector in cyclone bin assembly 110, the suction hose connector 108 can serve as a rotational alignment member 188 to help guide the cyclone bin assembly 110 into a desired orientation.

Alternatively, in other embodiments the suction hose connector 108 may be fixedly connected to the cyclone bin assembly 110, and may be removable with the cyclone bin assembly 110.

Cyclone Chamber Wherein Part of the Sidewall Moves with a Openable End Wall

Optionally, as exemplified in FIG. 12, the cyclone chamber sidewall 122 comprises a split sidewall that includes a first portion 204 and a second portion 206. The first portion 204 remains in position when the second dirt collection chamber end wall 144 is opened. For example, first portion 204 may be attached to, and may be integral with, the first dirt collection chamber end wall 142. The second portion 206 is movable with the second dirt collection chamber end wall 144. When assembled, with the second dirt collection chamber end wall 144 in the closed position, the first and second portions 204, 206 provide a generally continuous and generally air impermeable cyclone sidewall 122.

The second portion 206 may include a notch 208 that is shaped to receive a corresponding tab 210 on the first portion 204. Preferably, the notch 208 in the second portion 206 is provided toward the free end (i.e. opposed to the pivoting end) of the second dirt collection chamber end wall 126, and away from the hinge 212. Providing the notch 208 in this location may help enable dirt and debris to be emptied from

cyclone chamber 118 and may help reduce the likelihood of dirt and debris being retained by within the cyclone chamber 118 when the second dirt collection chamber end wall 144 is opened. For example, when second end wall 126 is pivoted open and faces downwardly, dirt on the surface of end wall 126 may fall through notch 208. It will be appreciated that notch preferably extends all the way to the surface of end wall 126 and may extend varying amounts around the sidewall 122.

Inlet 128 has an upper surface 128a (see FIG. 12). In the preferred embodiment, inlet 128 extends through the dirt collection chamber 120 and is mounted or moveable with end wall 126. Accordingly, the upper surface 128a comprises a dirt settling surface of the dirt collection chamber 120. When the dirt collection chamber is opened, inlet 128 moves with end wall 128. Accordingly, upper surface 128a is exposed and may face downwardly, thereby allowing dirt that has accumulated on upper surface 128a to be emptied.

Optionally, the vortex finder 134 and screen 136 are movable with the second cyclone end wall 126. In the illustrated example, the vortex finder 134 is integrally molded with the first cyclone end wall 124. In the illustrated example the dirt collection chamber sidewall 140 is a continuous, integral wall and does not split into upper and lower portions, or move with the second dirt collection chamber end wall 144.

Enhanced Dirt Collection Chamber Capacity

Preferably, the dirt collection chamber 120 surrounds a portion of the main body and, preferably a portion of the suction motor housing 216. Referring to FIGS. 7, 8, 10 and 13, the dirt collection chamber sidewall 140 comprises a recess 214 that is shaped to receive a corresponding portion of the body 112. In the illustrated example, the recess 214 is shaped to receive a portion of the motor housing 216 surrounding the suction motor 114. In this example, at least a portion of the dirt collection chamber 120 is positioned between the cyclone chamber 118 and the suction motor 114. Preferably, at least a portion of the dirt collection chamber 120 surrounds at least a portion of the suction motor 114 and the suction motor housing 216. In the illustrated example, the dirt collection chamber 120 surrounds only a portion of the motor housing 216. The shape of the recess 214 is preferably selected to correspond to the shape of the suction motor housing 216. Configuring the dirt collection chamber 120 to at least partially surround the suction motor housing 216 may help reduce the overall length of the surface cleaning apparatus 100, and/or may help increase the capacity of the dirt collection chamber 120.

The dirt collection chamber 120 may surround at least a portion of the cyclone chamber 118. Optionally, the dirt collection chamber 120 may be configured to completely surround the cyclone chamber 118.

Enhanced Filter Capacity

Preferably a filter (e.g., the pre-motor filter) overlies part or all of the cyclone bin assembly and the suction motor. This may increase the size of the pre-motor filter while maintaining a smaller footprint.

As exemplified in FIG. 13, air exiting the cyclone chamber 118 preferably flows to a suction motor 114 inlet via a filter chamber 186. The filter chamber 186 is provided downstream from the cyclone air outlet. Preferably, as exemplified, the filter chamber 186 extends over substantially the entire lower portion of the body 112 and overlies substantially all of the cyclone chamber 118, dirt collection chamber 120 and suction motor 114.

A pre-motor filter 218 is provided in the filter chamber 186 to filter the air before it enters the suction motor inlet

220. The pre-motor filter **218** is preferably sized to cover the entire transverse area of the filter chamber **186**, and thereby overlies substantially all of the cyclone chamber **118**, dirt collection chamber **120** and suction motor **114**.

It will be appreciated that filter chamber **186** and pre-motor filter **218** may be smaller. Preferably, the cross sectional area (in the direction of air flow) of the pre-motor filter **218** is greater than the cross sectional area of the cyclone chamber **118** and/or the suction motor **114**. In the illustrated example, the pre-motor filter **218** preferably comprises first and second pre-motor filters **218a**, **218b**. The filter chamber **186** comprises an air inlet chamber **222** on the upstream side **224** of the pre-motor filter **218**, and an air outlet chamber **226** on the downstream side **228** of the pre-motor filter **218**. Air can travel from the air inlet chamber **222** to the air outlet chamber **226** by flowing through the air-permeable pre-motor filter **218**.

Preferably, the outer face (the side facing away from the cyclone air outlet) is the upstream side of the filter. Accordingly, the air inlet chamber **222** is spaced from and fluidly may be connected to the cyclone chamber air outlet by an inlet conduit **230** that extends through the pre-motor filter **218**. In the illustrated example, the inlet conduit **230** is an extension of the vortex finder insert **180**. The air outlet chamber **226** is in fluid communication with the inlet **220** of the suction motor **114**.

The pre-motor filter **218** may be supported by a plurality of support ribs **232** extending through the air outlet chamber **226**. Gaps or cutouts **234** can be provided in the ribs **232** to allow air to circulate within the air outlet chamber **226** and flow toward the suction motor inlet **220**.

From the suction motor inlet **220**, the air is drawn through the suction motor **114** and ejected via a suction motor outlet **116**. Optionally, a post-motor filter **236** (for example a HEPA filter) can be provided downstream from the suction motor outlet **116**, between the suction motor outlet **116** and the clean air outlet **104**. A detachable grill **238** can be used to retain the post-motor filter **236** in position, and allow a user to access the post-motor filter **236** for inspection or replacement.

A bleed valve **240** may be provided to supply bleed air to the suction motor inlet **220** in case of a clog. The bleed valve **240** may be a pressure sensitive valve that is opened when there is a blockage in the air flow path upstream from the suction motor **114**. Preferably, as exemplified, the bleed valve **240** may be co-axial with the suction motor **114** and may extend through the pre-motor filter **218**. A bleed valve inlet **242** (see also FIG. **5**) may be provided toward the rear of the body **112**.

Optionally, a first end wall **244** of the filter chamber **186** can be openable to allow a user to access the pre-motor filter **218**. In the illustrated example, the filter chamber end wall **244** is pivotally connected to the body **112** by a hinge **246** and can pivot to an open position. Releasable latch **150** may be used to secure the first end wall **244** in a closed position. The latch **150** can connect the filter chamber endwall to the cyclone bin assembly **110**.

Hose Wrap

Preferably, a suction hose wrap is provided and the accessory tools are provided in a recess in the hose wrap and, preferably, in the bottom of the hose wrap. Alternately, or in addition, the suction hose wrap is located at one end of the vacuum cleaner (e.g., the bottom) and preferably is the stand of the vacuum cleaner (i.e., it is the part that sits on the floor).

Referring to FIGS. **1-9**, the surface cleaning apparatus **100** may include a hose wrap portion **248**, which may be of

any design. The hose wrap portion **248** may be provided at either opposed end (e.g. top or bottom if oriented upright as illustrated) of the surface cleaning apparatus. Preferably, as exemplified, the hose wrap portion **248** extends from the bottom surface of the openable filtration chamber end wall **244** or, if an openable filter chamber is not provided, from the bottom of the platform.

Preferably, the hose wrap portion **148** functions as a stand for the surface cleaning apparatus. Accordingly, referring to FIG. **7**, the hose wrap portion **248** may include a generally flat lower surface **250** and therefore function as a stand to support the surface cleaning apparatus **100** when it is not in use. Optionally, the lower surface **250** can function as a stand and can include a plurality of support feet **252** configured to rest upon a surface (for example a floor or a counter top). In the illustrated example, the surface **250** includes three integral support feet **252** formed from bosses extending from the lower surface **250**.

Preferably, as exemplified in FIGS. **1-6**, a suction hose recess **254** extends around the perimeter of the hose wrap portion **248**. The suction hose recess **254** preferably has a radius of curvature **256** (FIG. **6**) that is selected to generally match the radius of curvature of a suction hose **109** that can be used in combination with the surface cleaning apparatus **100**. When the suction hose **109** is not in use, it can be wrapped around the hose wrap portion **248** for storage and may be at least partially received in the suction hose recess **254**.

Referring to FIGS. **1-3**, optionally, the suction hose recess **254** can include a hose securing detent **258**, comprising upper and lower detent members **260**, **262**. The upper and lower detent **260**, **262** members can frictionally engage a corresponding segment **264** of the suction hose **109**. Engaging the suction hose **109** with the hose securing detent **258** may help retain the hose **109** in its storage position, within the hose recess **254**. The suction hose segment **264** can include a hose detent groove **266** for receiving the upper and lower detent members **260**, **262**. Retaining the upper and lower detent members **260**, **262** in the hose detent groove **266** can help prevent the suction hose **109** from sliding axially relative within the recess **254** while the suction hose **109** is wrapped in the recess **254**. Optionally, the segment **264** of the suction hose retained by the upper and lower detent members **260**, **262**, and comprising the hose detent groove **266** can be separate hose retaining member **268** coupled to the suction hose **109**. The hose retaining member **268** may be stiffer than the suction hose **109**.

Alternatively, or in addition to the hose securing detent **258**, the hose wrap portion **248** can include a hose securing member. In the illustrated example, the hose securing member comprises a mounting flange **270** that is shaped to engage a corresponding mounting notch **272** located on the suction hose **109**. Sliding the mounting notch **272** over the flange **270** can help secure the upstream end of the suction hose in the storage position, in close proximity to the hose wrap portion **248**. Optionally, the mounting notch **272** can be formed on a separate collar **274** that is coupled to the suction hose **109**.

Referring to FIG. **13**, in the illustrated example, the hose wrap portion **248** is arranged so that when the suction hose **109** is wrapped within the hose wrap recess **254**, the plane **276** containing the suction hose is generally orthogonal to a cyclone axis **138** and a suction motor axis **278**, as explained in greater detail below. Alternatively, the hose wrap portion **248** can be configured so that the plane **276** containing the suction hose is not orthogonal to one or both of the cyclone and suction motor axes **138**, **278**.

13

In the illustrated example, the hose wrap portion **248** is integrally formed from molded plastic. Optionally, the hose wrap portion **248** can be releasably connected to the body **112**, and may be removable.

Referring to FIGS. **6**, **8** and **13**, optionally, the hose wrap portion **248** can include a tool cavity **280**. Preferably, as exemplified, the tool cavity **280** is provided in the lower surface of the hose wrap **248** and, more preferably generally centrally located within the perimeter of the hose wrap recess **254**. One or more accessory cleaning tools **282** may be stored within the tool cavity **280** when the accessory tools **282** are not in use.

Preferably, as exemplified, the tool cavity **280** may include four side walls **284**, an upper wall **286** and has an open bottom for allowing access to the tool stored **282** in the cavity **280**. The tool cavity **280** has a cavity depth **288**, a cavity width **290** and a cavity length **292**. Alternatively, the tool cavity **280** may have an enclosed bottom and at least one open side **284** to allow access to the accessory tool **282**, and/or the tool cavity **280** may include more than one open surface (for example the cavity may have an open bottom and at least one open side) or may have an openable door to provide access to the cavity. Preferably, the tool cavity **280** is configured so that the accessory tools **282** stored within the cavity **280** are accessible when the surface cleaning apparatus **100** is in use. More preferably, the tool cavity **280** is configured so that the accessory tools **282** in the cavity **280** are accessible while the suction hose is wrapped around the hose recess **254**.

Optionally, the tool cavity **280** may include tool holders **294** for releasably securing one or more accessory tools **282** within the tool cavity **280**. Preferably, as exemplified, the tool holder **294** comprises a tool mounting bracket extending from the upper wall **286** of the tool cavity **280**. Preferably, as exemplified, the cavity depth **288** is selected to be greater than the thickness of the accessory tool **282** that is contained within the cavity **280**, and the cavity width **290** and length are selected to be greater than the accessory tool width and length, respectively. Selecting a cavity **280** that is generally larger than the accessory tool **282** allows the accessory tool to be contained within the tool cavity **280**, without extending beyond the lower surface **250** of the hose wrap portion **248**. Recessing the accessory tool **282** within the cavity **280** may help enable the surface cleaning apparatus **100** to rest in a level orientation when the surface **250** is placed on a flat surface.

Cord Wrap

Preferably, a cord wrap is provided that permits the sliding removal of the cord without manually manipulating a cord retaining member (e.g., rotating a cord retaining member in a plane in which the cord is positioned when wrapped about the cord wrap).

Referring to FIGS. **4-6**, the surface cleaning apparatus **100** may optionally include an electrical cord wrap **296** extending, preferably, from the rear of the body **112**. The electrical cord wrap **296** comprises and at least two spaced apart cord retainers, e.g., upper cord retainer **298** and an opposing lower cord retainer **300** about which an electrical cord may be wound for storage. In the illustrated example, the upper cord retainer **298** is connected to the body **112** by an upper extension member **302**, and the lower cord retainer **300** is connected to the body **112** by a lower extension member **304**. Extension members are optionally provided if the location of the cord wrap is to be spaced from main body **12**.

Preferably, at least one of the upper and lower cord retainers **298**, **300** is moveable in a sliding cord removing

14

direction, between a cord storage position, for retaining the electrical cord on the cord wrap, and a cord removal position, to help facilitate the removal of the electrical cord from the cord wrap. Optionally, the moveable cord retainer includes a biasing member that is configured to bias the cord retainer toward the cord storage position. Preferably, a locking member is not provided to lock the cord wrap member in a cord retaining position. Accordingly, a user may remove the cord by sliding the cord off of the cord wrap member. The cord wrap member will then automatically return to the cord retaining position. When desired, the cord may then be wrapped about the cord retaining members. Alternately, the cord wrap member may be manually positionable in both the cord retaining position and the cord removal position.

In the illustrated example, the lower cord retainer **300** is movably coupled to the lower extension member **304** by pivot joints **306**. The lower cord retainer **300** is pivotable about rotational axis **308** (FIG. **6**) and is moveable between a cord storage position (FIG. **5**) and a cord removal position (FIG. **4**).

Referring to FIG. **5**, in the cord storage position, a retaining flange **310** extends generally transverse (e.g. downwardly), away from the lower extension member **304** and cooperates with a cord supporting surface **312** of the lower extension member **304** to form a retaining shoulder **314**. The height **316** of the retaining shoulder **314** can be selected so that it is sufficient to retain the electrical cord on the lower cord retainer **300**, and optionally, can be generally equal to or greater than the diameter of the electrical cord.

Referring to FIG. **4**, in the cord removal position, the lower cord retainer **300** is pivoted or moved in the cord removal direction (e.g. rearwardly) so that a distal end **318** of the retaining flange **310** is raised above a plane **320** containing the cord supporting surface **312**. Pivoting the retaining flange **310** above the plane **320** may help facilitate removal of the electrical cord coiled around the cord wrap **296**. When the lower cord retainer **300** is in the cord removal position, the lower end of the coiled electrical cord can be slid off the lower extension member **304**, in the direction indicated using arrow **322**, without needing to pass over the retaining shoulder **314**.

Preferably, the lower cord retainer **300** is biased toward the cord storage position. Referring to FIG. **6**, in the illustrated example, each pivot joint **306** includes a spring member **324** biasing the lower cord retainer **300** toward the cord storage position. The stiffness of the springs **324** can be selected so that the lower cord retainer **300** can remain in the cord storage position and retain the electrical cord on the cord wrap **296** under normal handling, for example when the orientation of the surface cleaning apparatus **100** is changed while the electrical cord is wrapped. Optionally, the stiffness of the springs **324** can also be selected so that the force of a user pulling the coiled electrical cord off the cord wrap **296** is sufficient to overcome the spring force. Configuring the springs **324** to yield when a user attempts to remove the electrical cord from the cord wrap **296** may help facilitate an automatic rotation of the lower cord retainer **300**, allowing the cord to be removed without requiring the user to first manually adjust the position of the lower cord retainer **300**. When the electrical cord is clear of the lower cord retainer **300**, the biasing force of the springs **324** may return the lower cord retainer **300** to the cord storage position. Automatically returning the lower cord retainer **300** to the cord storage position may help ensure that the cord wrap **296** is configured to retain the electrical cord when the user chooses to replace the electrical cord on the cord wrap **296**.

Optionally, instead of, or in addition, to one or more springs 324, the biasing member for returning the lower cord retainer to the cord storage position may be another type of biasing device, including, for example an elastic member and a living hinge.

Referring to FIG. 5, in the illustrated example, the upper cord retainer 298 is a static cord retainer. The upper cord retainer 298 includes a static flange 326 (i.e., non-moveable) that cooperates with the cord supporting surface 328 of the upper extension member 302 to provide a cord retaining shoulder 330. In the illustrated example, the upper cord retainer 298 is integrally formed with the upper extension member 302. Optionally, in other embodiments the lower cord retainer 300 can be static and the upper cord retainer 300 can be the moveable cord retainer, or both the upper and lower cord retainers 298, 300 can be movable. In the illustrated example, the upper and lower cord retainers 298, 300 are located on opposite ends of the clear air outlet 104.

Optionally, an accessory tool holder 332 may be provided on the electrical cord wrap 296. Referring to FIGS. 5 and 6, the accessory tool holder comprises a tool mounting post 334 extending upward from the lower extension member 304. The tool mounting post 334 is sized to be received within the air outlet 338 of an accessory cleaning tool, including, for example a turbo brush 336 (FIG. 4). Preferably, the tool mounting post 334 has a slight friction or interference fit with the inner surface of the air outlet 338. Providing an interference fit between the tool mounting post 334 and the accessory tool may help to retain the accessory tool on the tool mounting post when the surface cleaning apparatus 100 is in use. Optionally, the interference fit between the tool mounting post 334 and the accessory tool may be the only retaining mechanism used to hold the turbo brush on the surface cleaning apparatus 100. Alternatively, or in addition to the interference fit, additional retaining mechanisms, including for example, clips, latches and magnets, can be used to help hold the turbo brush on the tool mounting post.

Preferably, the upper and lower cord retainers 298, 300 are spaced apart from each other by a distance that allows for at least a portion of the accessory tool to be disposed between the upper and lower cord retainers 298, 300. In this configuration, the accessory tool can be positioned relatively close to the rear of the body 112. Positioning the turbo brush 336 in close proximity to the body 112 may help reduce the overall length of the surface cleaning apparatus 100.

It will be appreciated that the following claims are not limited to any specific embodiment disclosed herein. Further, it will be appreciated that any one or more of the features disclosed herein may be used in any particular combination or sub-combination, including, without limitation, a moveable or removable power switch (preferably on or proximate the handle), a hose connector that is recessed into the cyclone bin assembly and preferably having the hose connector mounted to the main body and not a removable air treatment member, a suction hose wrap with a tool storage compartment, a suction hose wrap provided at one end, and preferably a lower end, of a surface cleaning apparatus whereby it may form a stand or base, a cord wrap with an automatic cord release which permits the sliding removal of the cord without having to manually move a cord retaining member, a cyclone chamber having a removable vortex finder or vortex finder insert, A dirt bin that partially surrounds the suction motor or suction motor housing, a

filter that overlies at least part of a cyclone bin assembly and a suction motor and a cyclone chamber having a wall that splits when the cyclone chamber is opened.

What has been described above has been intended to be illustrative of the invention and non-limiting and it will be understood by persons skilled in the art that other variants and modifications may be made without departing from the scope of the invention as defined in the claims appended hereto.

The invention claimed is:

1. A portable surface cleaning apparatus having an upper end, a lower end, a horizontal plane extending transversely through the portable surface cleaning apparatus at a midpoint between the upper end and the lower end, a front end having a front face and a rear end, the portable surface cleaning apparatus comprising:

- (a) an air flow path extending from a dirty air inlet to a clean air outlet, the dirty air inlet connectable to a wand;
- (b) a main body having an upper end and a lower end and comprising a suction motor provided in the air flow path, the suction motor having a suction motor axis, the suction motor axis intersects the upper end of the surface cleaning apparatus and the lower end of the surface cleaning apparatus;
- (c) an air treatment member provided in the air flow path, the air treatment member comprising a cyclone chamber having an upper end, a lower end, a cyclone chamber air inlet, a single cyclone chamber air outlet and a cyclone chamber axis, the cyclone chamber axis intersects the upper end of the surface cleaning apparatus and the lower end of the surface cleaning apparatus, the lower end of the cyclone chamber has the cyclone chamber air inlet and the cyclone chamber air outlet;
- (d) a handle provided on the upper end of the portable surface cleaning apparatus; and,
- (e) a pre-motor filter located underneath at least one of the cyclone chamber and the suction motor,

wherein the dirty air inlet is provided in the front face at a location below the horizontal plane, and, wherein the handle overlies a portion of the air treatment member and the suction motor, and wherein the air flow path includes a portion that extends downstream from the cyclone chamber air outlet under the lower end of the cyclone chamber to a suction motor air inlet.

2. The surface cleaning apparatus of claim 1 wherein the handle also overlies a portion of a pre-motor filter.

3. The surface cleaning apparatus of claim 1 wherein the dirty air inlet is provided at the lower end of the portable surface cleaning apparatus.

4. The surface cleaning apparatus of claim 1 wherein the cyclone chamber is provided in a cyclone bin assembly that is removably mounted to the main body.

5. The surface cleaning apparatus of claim 1 wherein the cyclone chamber axis and the suction motor axis are generally parallel.

6. The surface cleaning apparatus of claim 1 wherein the handle extends in a rearward direction.

7. The surface cleaning apparatus of claim 1 wherein the suction motor underlies a rearward portion of the handle.