



(12) **United States Patent**
Conrad

(10) **Patent No.:** **US 11,026,550 B2**
(45) **Date of Patent:** **Jun. 8, 2021**

(54) **SURFACE CLEANING APPARATUS,
CYCLONIC AIR TREATMENT MEMBER
AND SURFACE CLEANING APPARATUS
INCLUDING THE SAME**

(58) **Field of Classification Search**

CPC . A47L 9/1675; A47L 9/32; A47L 9/22; A47L
9/1691; A47L 9/20; A47L 9/325; A47L
9/106; A47L 9/122; A47L 9/1608; A47L
9/1625; A47L 9/165; A47L 9/1683; A47L
5/28; A47L 9/1658; B04C 5/081;
(Continued)

(71) Applicant: **Omachron Intellectual Property Inc.,**
Hampton (CA)

(72) Inventor: **Wayne Ernest Conrad,** Hampton (CA)

(73) Assignee: **Omachron Intellectual Property Inc.,**
Hampton (CA)

(*) Notice: Subject to any disclaimer, the term of this
patent is extended or adjusted under 35
U.S.C. 154(b) by 0 days.

(56) **References Cited**

U.S. PATENT DOCUMENTS

394,240 A 12/1888 Allington
2,192,357 A * 3/1940 Leathers A47L 9/20
55/305

(Continued)

(21) Appl. No.: **16/806,800**

FOREIGN PATENT DOCUMENTS

(22) Filed: **Mar. 2, 2020**

GB 2370006 B 10/2003

(65) **Prior Publication Data**

US 2020/0229665 A1 Jul. 23, 2020

Related U.S. Application Data

(63) Continuation-in-part of application No. 16/447,308,
filed on Jun. 20, 2019, which is a continuation-in-part
(Continued)

OTHER PUBLICATIONS
International Search Report and Written Opinion, received in
connection to international patent application No. PCT/CA2020/
050054, dated Apr. 8, 2020.

Primary Examiner — Dung H Bui

(74) *Attorney, Agent, or Firm* — Philip C. Mendes da
Costa; Bereskin & Parr LLP/ S.E.N.C.R.L., s.r.l.

(51) **Int. Cl.**

B01D 50/00 (2006.01)
A47L 9/16 (2006.01)

(Continued)

(57) **ABSTRACT**

A surface cleaning apparatus comprises an air treatment
member having an air treatment chamber. A moveable
member is positioned in the air treatment chamber. A driving
assembly is drivingly connected to the moveable member
wherein the driving assembly is reconfigurable between a
stored position and an operable position in which the driving
assembly is operable to longitudinally translate the move-
able member through at least a portion of the chamber.

(52) **U.S. Cl.**

CPC **A47L 9/1675** (2013.01); **A47L 9/22**
(2013.01); **A47L 9/32** (2013.01); **A47L 9/106**
(2013.01); **A47L 9/122** (2013.01); **A47L**
9/1608 (2013.01); **A47L 9/1625** (2013.01);
A47L 9/1683 (2013.01); **A47L 9/1691**
(2013.01); **A47L 9/20** (2013.01);
(Continued)

20 Claims, 158 Drawing Sheets

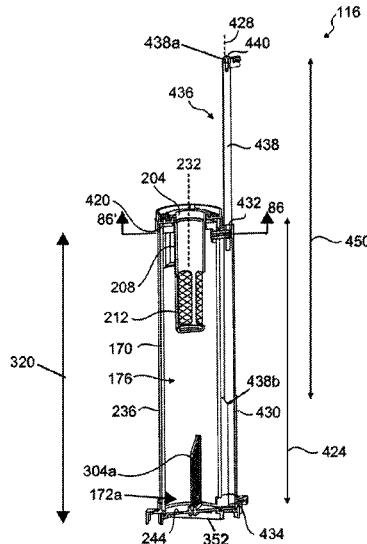

Related U.S. Application Data

of application No. 16/254,918, filed on Jan. 23, 2019,
now Pat. No. 10,828,649.

(51) **Int. Cl.**

A47L 9/32 (2006.01)
A47L 9/22 (2006.01)
A47L 9/20 (2006.01)
A47L 9/10 (2006.01)
A47L 9/12 (2006.01)
B04C 5/081 (2006.01)
B04C 5/103 (2006.01)
B04C 5/04 (2006.01)
B04C 9/00 (2006.01)
B04C 5/185 (2006.01)

6,979,358 B2 12/2005 Ekker et al.
7,022,154 B2 4/2006 Oh
7,803,207 B2 9/2010 Conrad
7,882,593 B2 2/2011 Beskow et al.
7,922,794 B2 4/2011 Morphey
7,958,597 B2 6/2011 Frantzen et al.
8,069,529 B2 12/2011 Groff et al.
8,156,609 B2 4/2012 Milne et al.
8,236,077 B2 8/2012 Gomiciaga-Pereda et al.
8,424,154 B2 4/2013 Beskow et al.
8,549,704 B2 10/2013 Milligan et al.
8,567,008 B2 10/2013 Conrad
8,607,406 B2 12/2013 Miefalk et al.
8,607,407 B2 12/2013 Conrad
8,640,304 B2 2/2014 Conrad
8,769,764 B2 7/2014 Crouch et al.
9,009,912 B2 4/2015 Conrad
9,027,198 B2 5/2015 Conrad

(52) **U.S. Cl.**

CPC *A47L 9/325* (2013.01); *B04C 5/04*
(2013.01); *B04C 5/081* (2013.01); *B04C 5/103*
(2013.01); *B04C 5/185* (2013.01); *B04C 9/00*
(2013.01); *B04C 2009/004* (2013.01)

2006/0090290 A1 5/2006 Lau
2006/0283158 A1* 12/2006 Kennedy A47L 9/20
55/300
2008/0244860 A1* 10/2008 Gammack A47L 9/325
15/410
2008/0256744 A1* 10/2008 Rowntreer A47L 9/20
15/350

(58) **Field of Classification Search**

CPC .. B04C 5/04; B04C 5/103; B04C 9/00; B04C
5/185; B04C 2009/004

See application file for complete search history.

2009/0049639 A1* 2/2009 Gordon A47L 9/2842
15/319
2011/0289720 A1 12/2011 Han et al.
2012/0311979 A1 12/2012 Conrad
2014/0020205 A1* 1/2014 Makarov A47L 5/28
15/353

(56)

References Cited

U.S. PATENT DOCUMENTS

3,636,682 A 1/1972 Rush
4,203,961 A 5/1980 Cowley
6,406,505 B1 6/2002 Oh et al.
6,837,912 B1 1/2005 Heumann

2014/0366310 A1 12/2014 Conrad
2018/0055310 A1* 3/2018 Conrad A47L 9/242
2018/0055318 A1* 3/2018 Gottschall A47L 9/102
2018/0132685 A1* 5/2018 Muir A47L 5/225
2018/0353030 A1* 12/2018 Wall A47L 5/30
2018/0353035 A1* 12/2018 Kwak A47L 9/2805

* cited by examiner

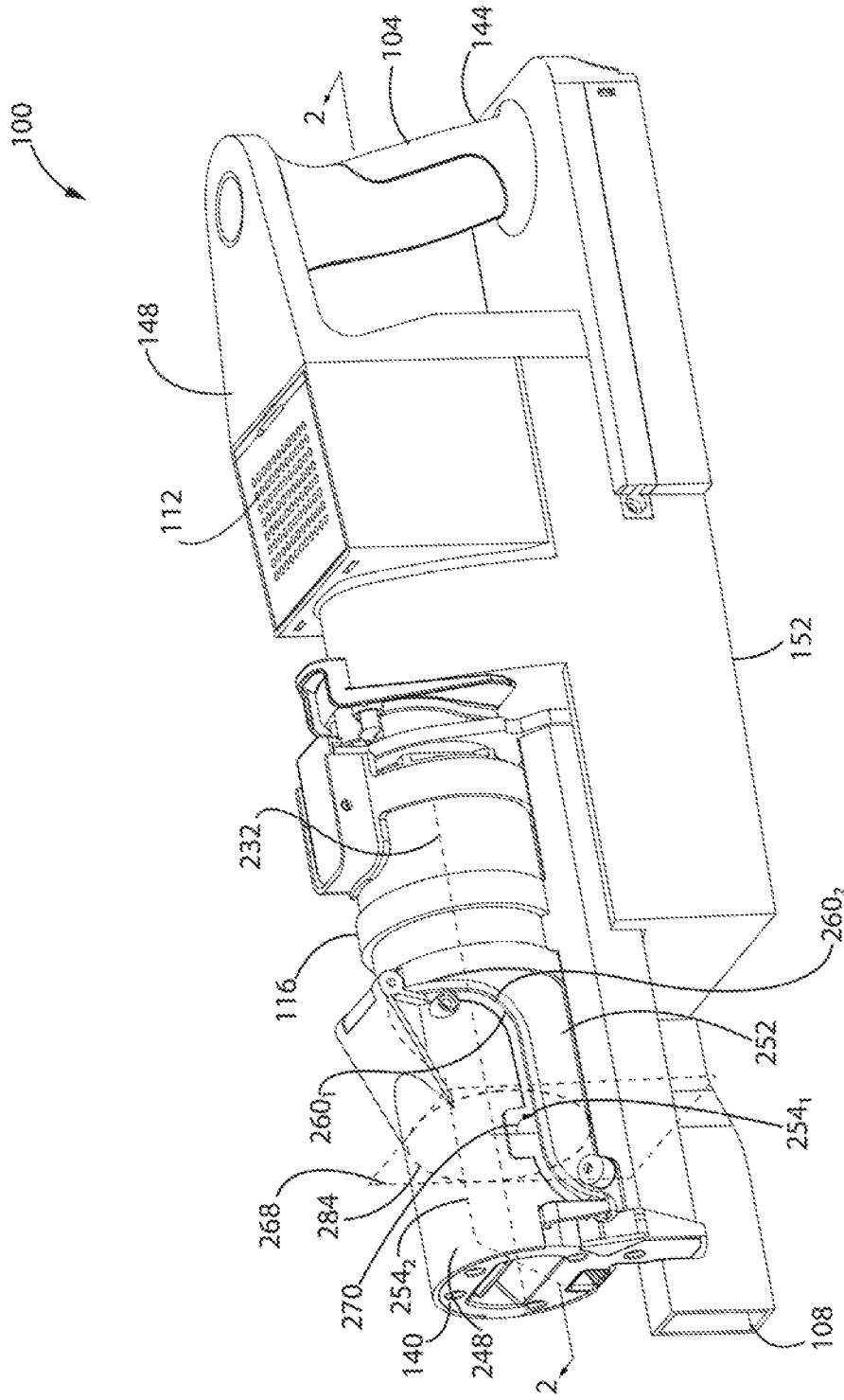

FIG. 1

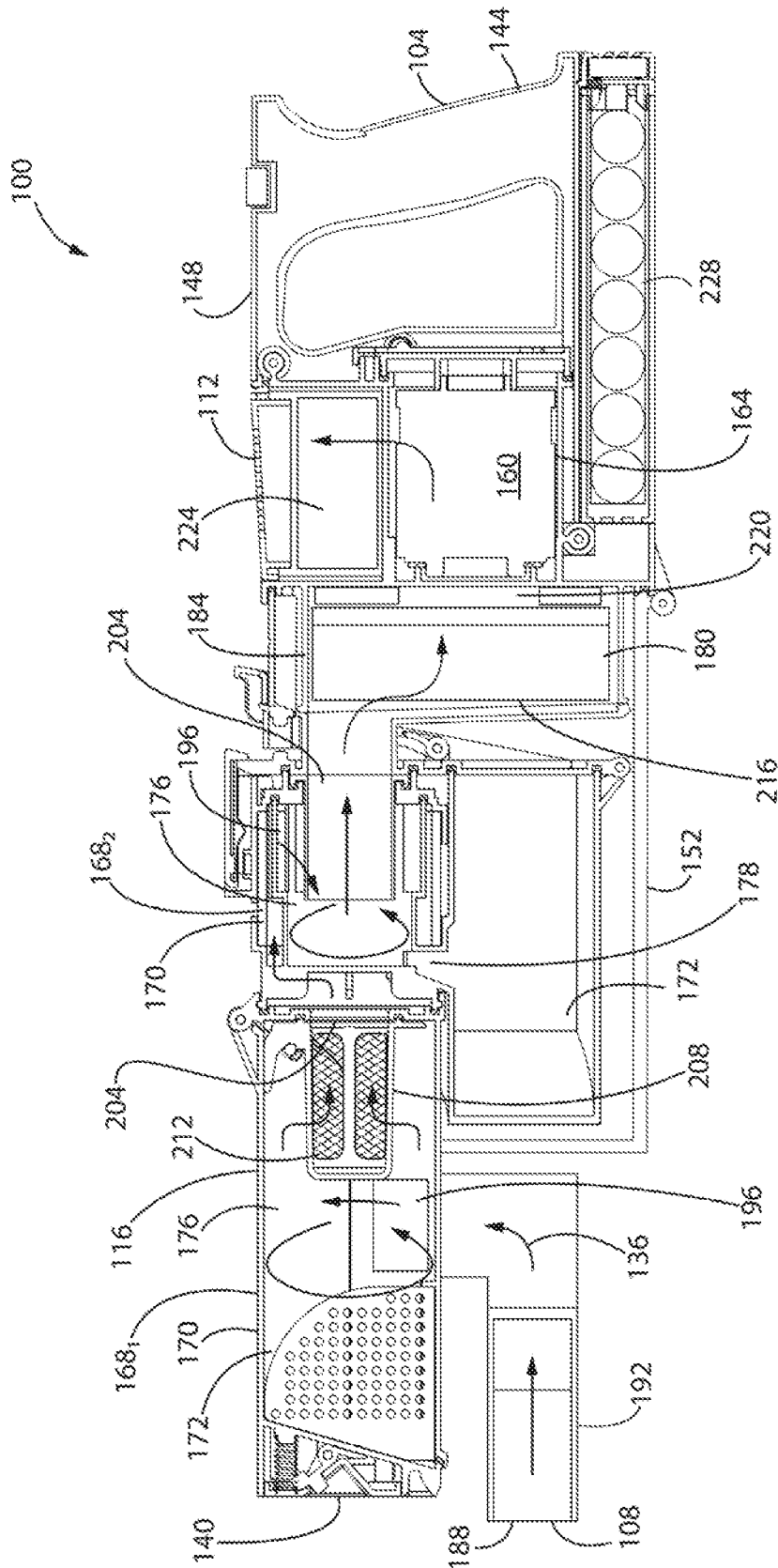

FIG. 2

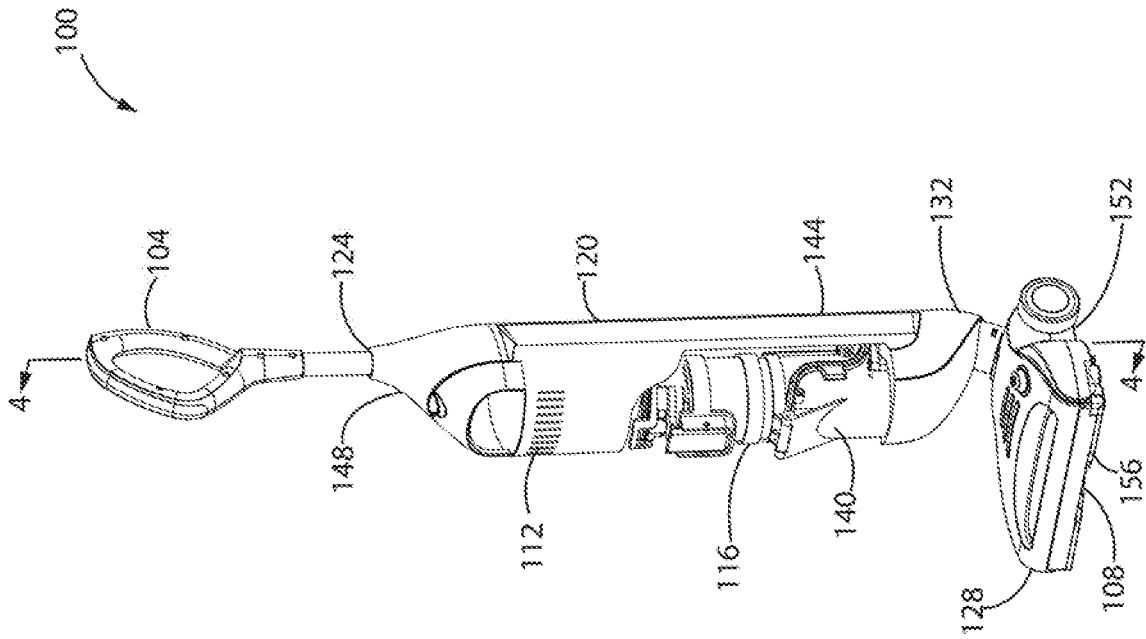

FIG. 3

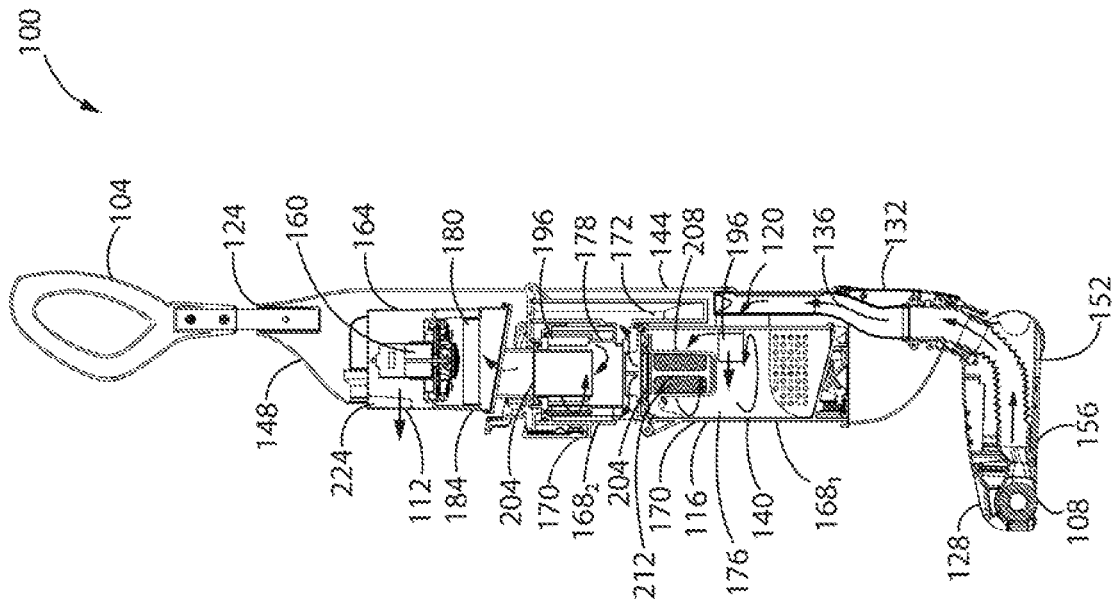

FIG. 4

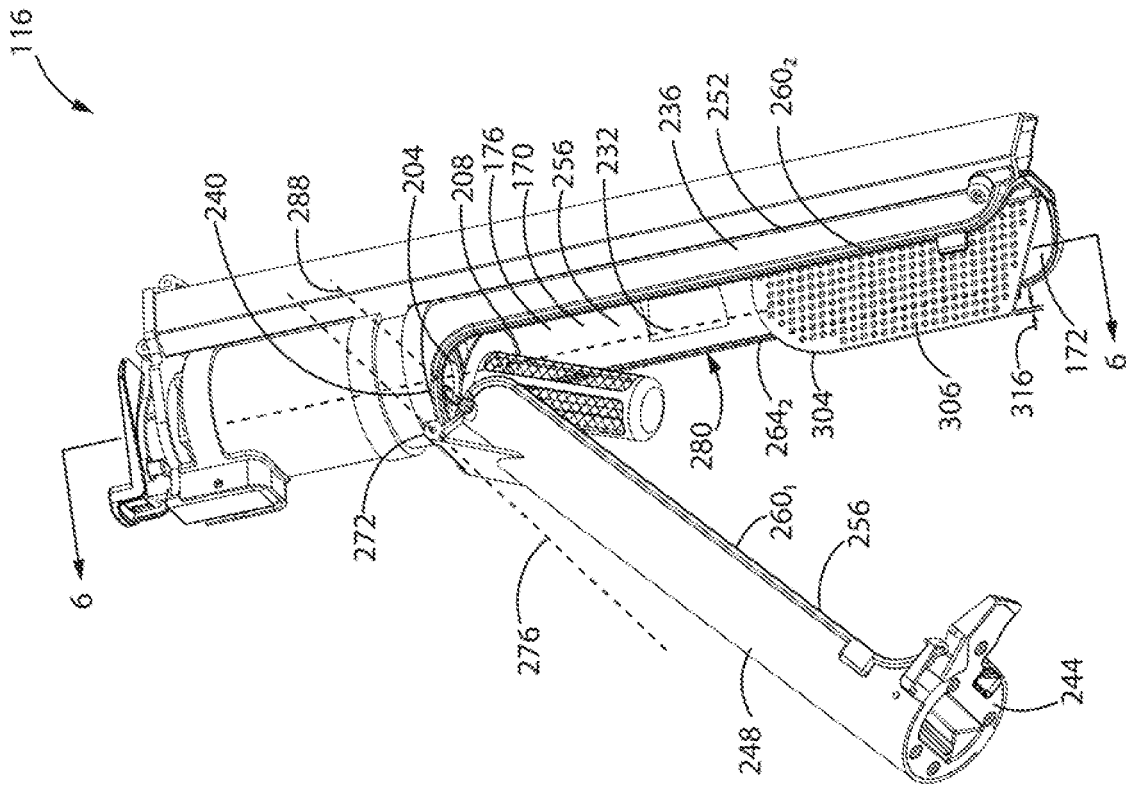

FIG. 5

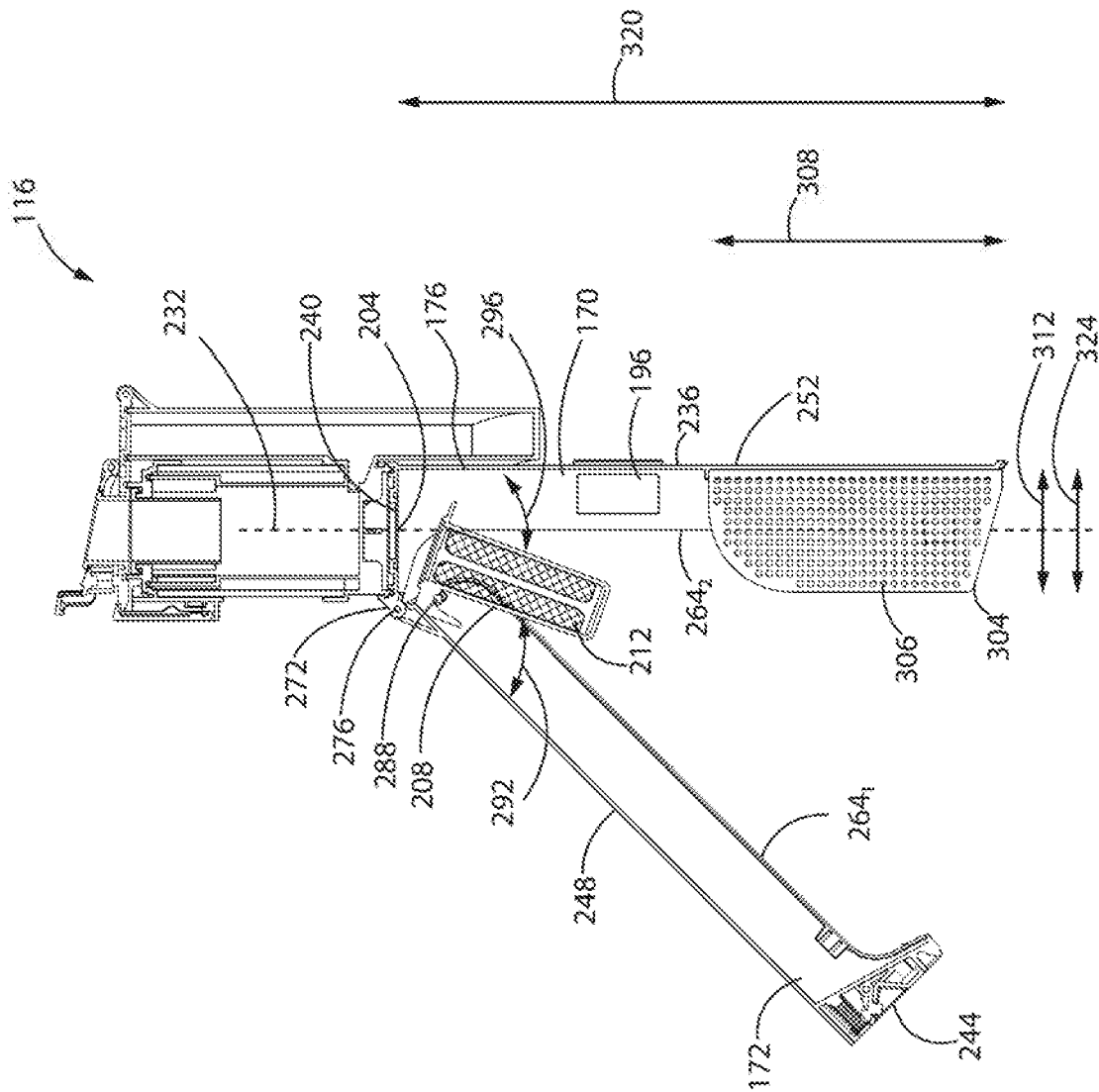

FIG. 6

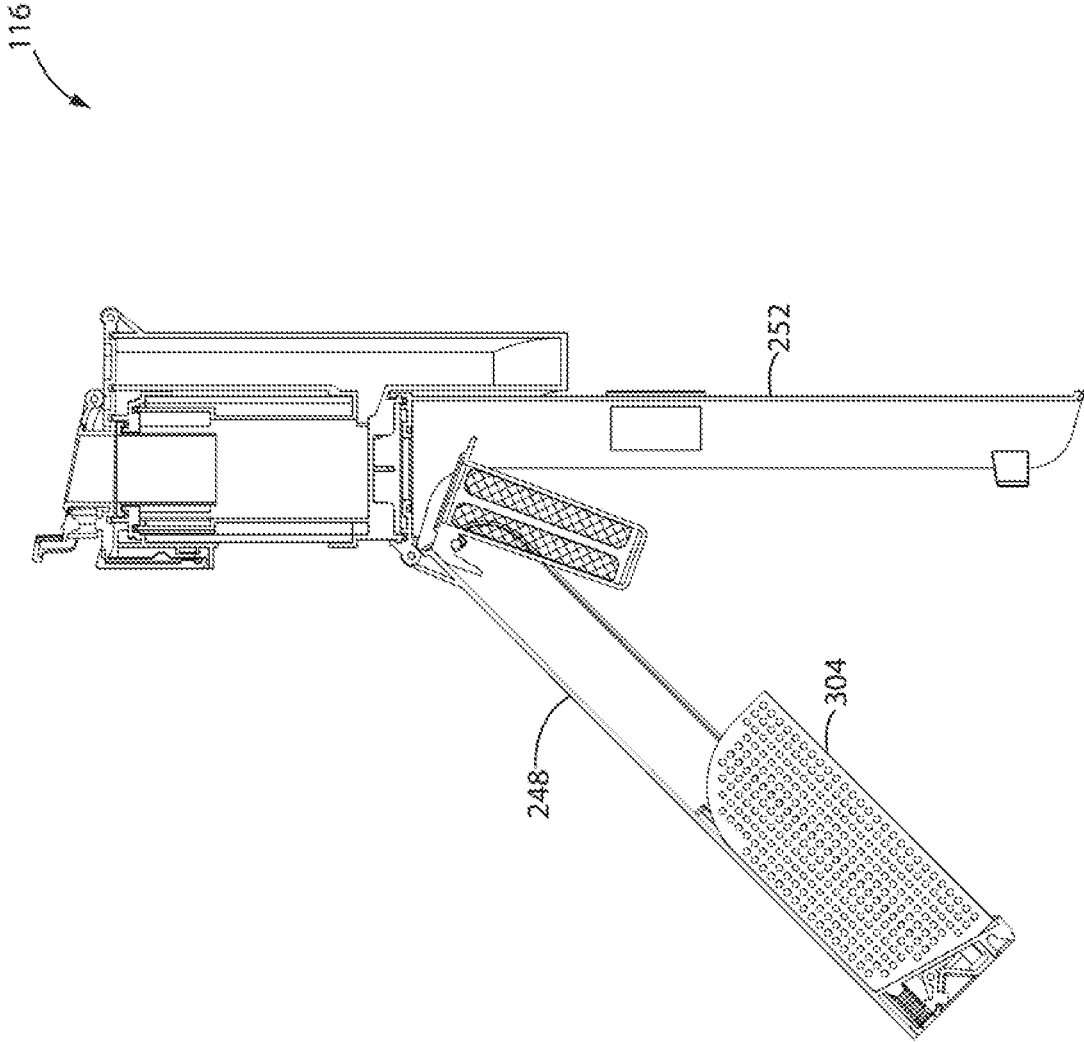

FIG. 7

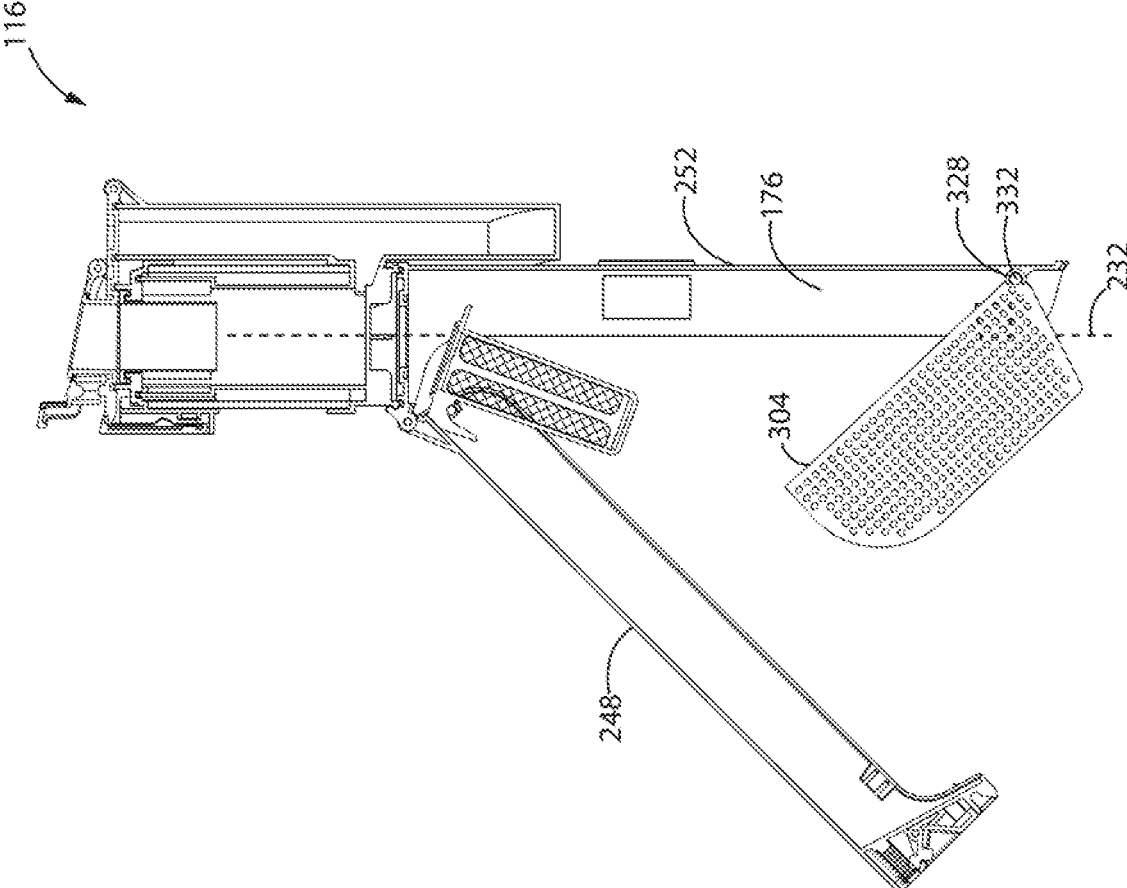

FIG. 8

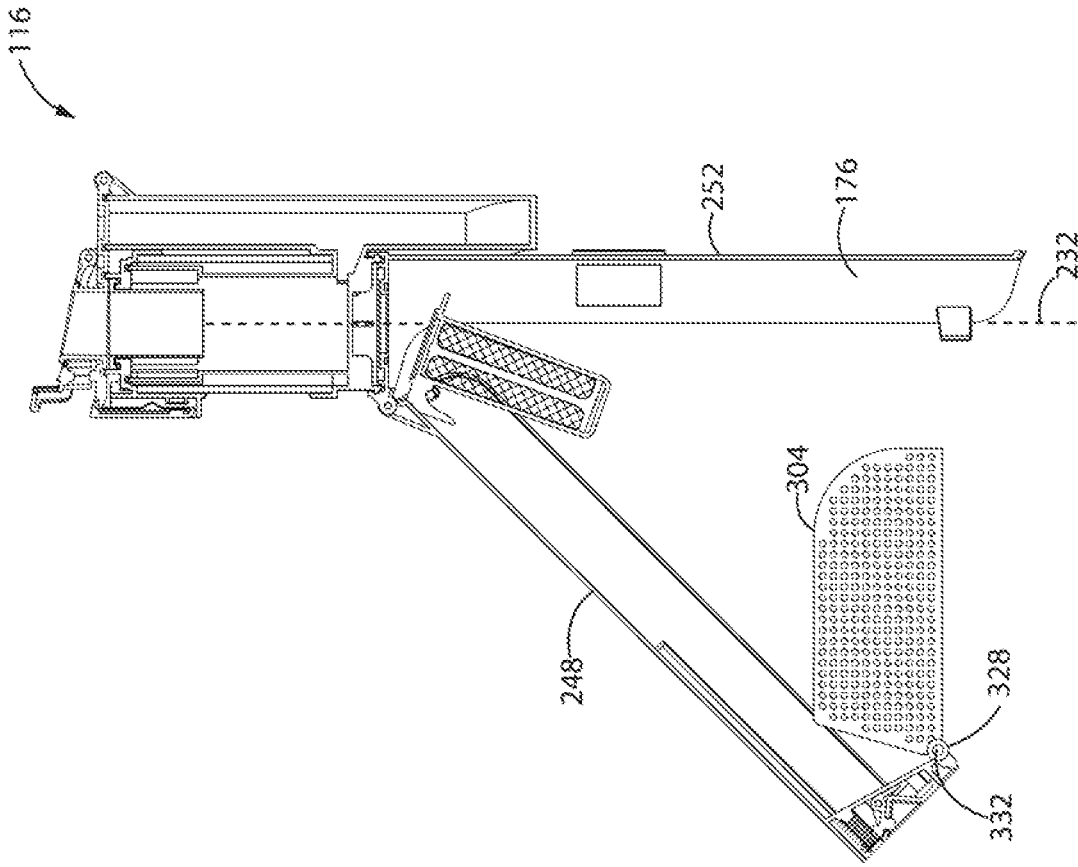

FIG. 9

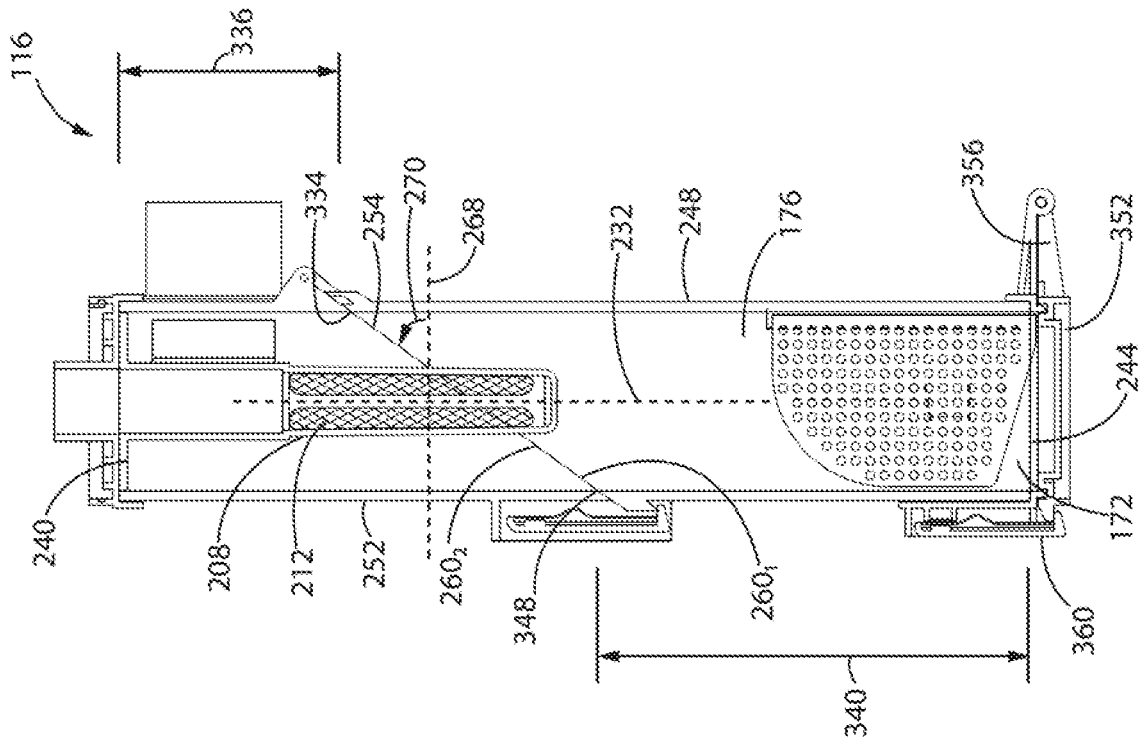

FIG. 10

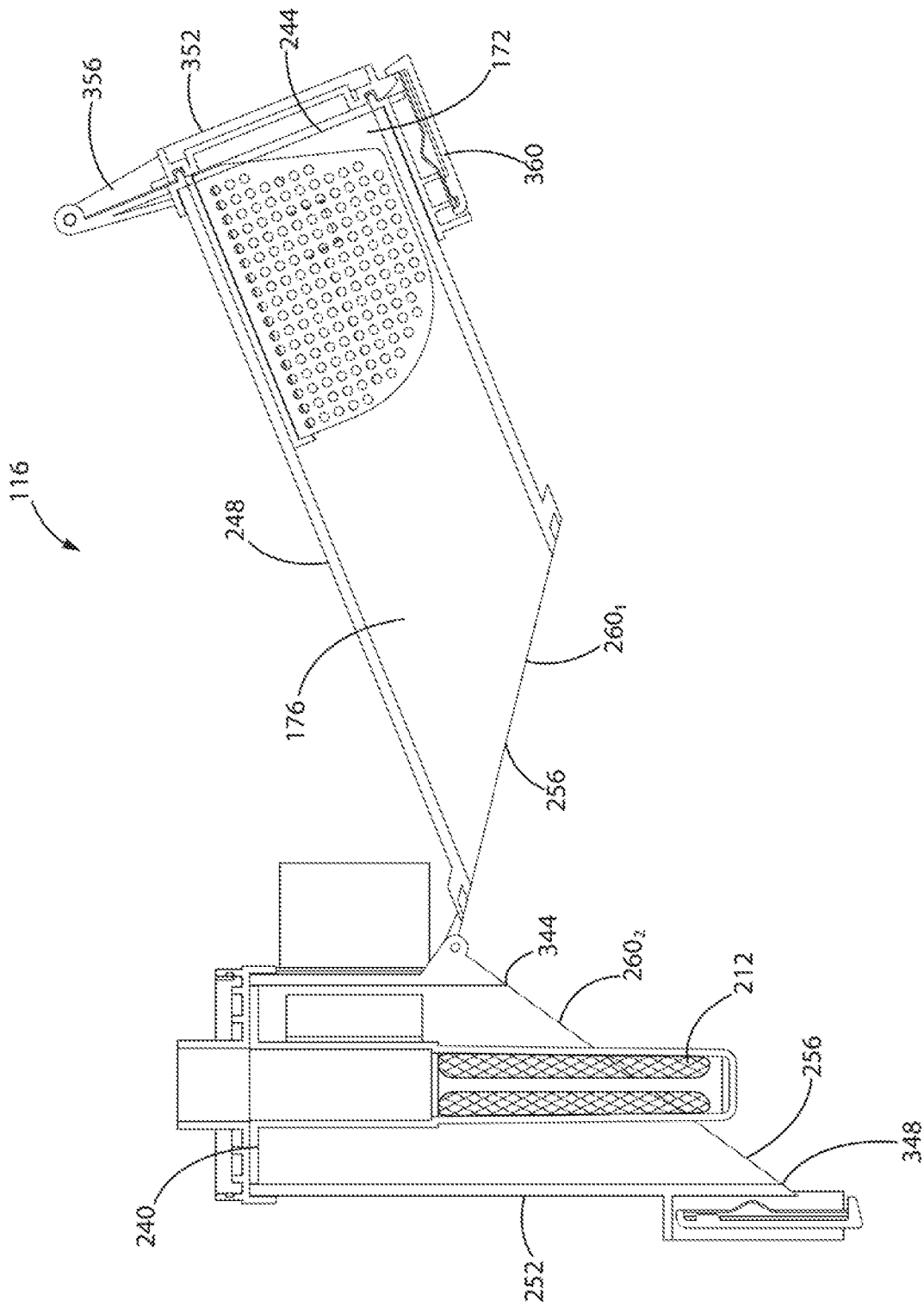

FIG. 11

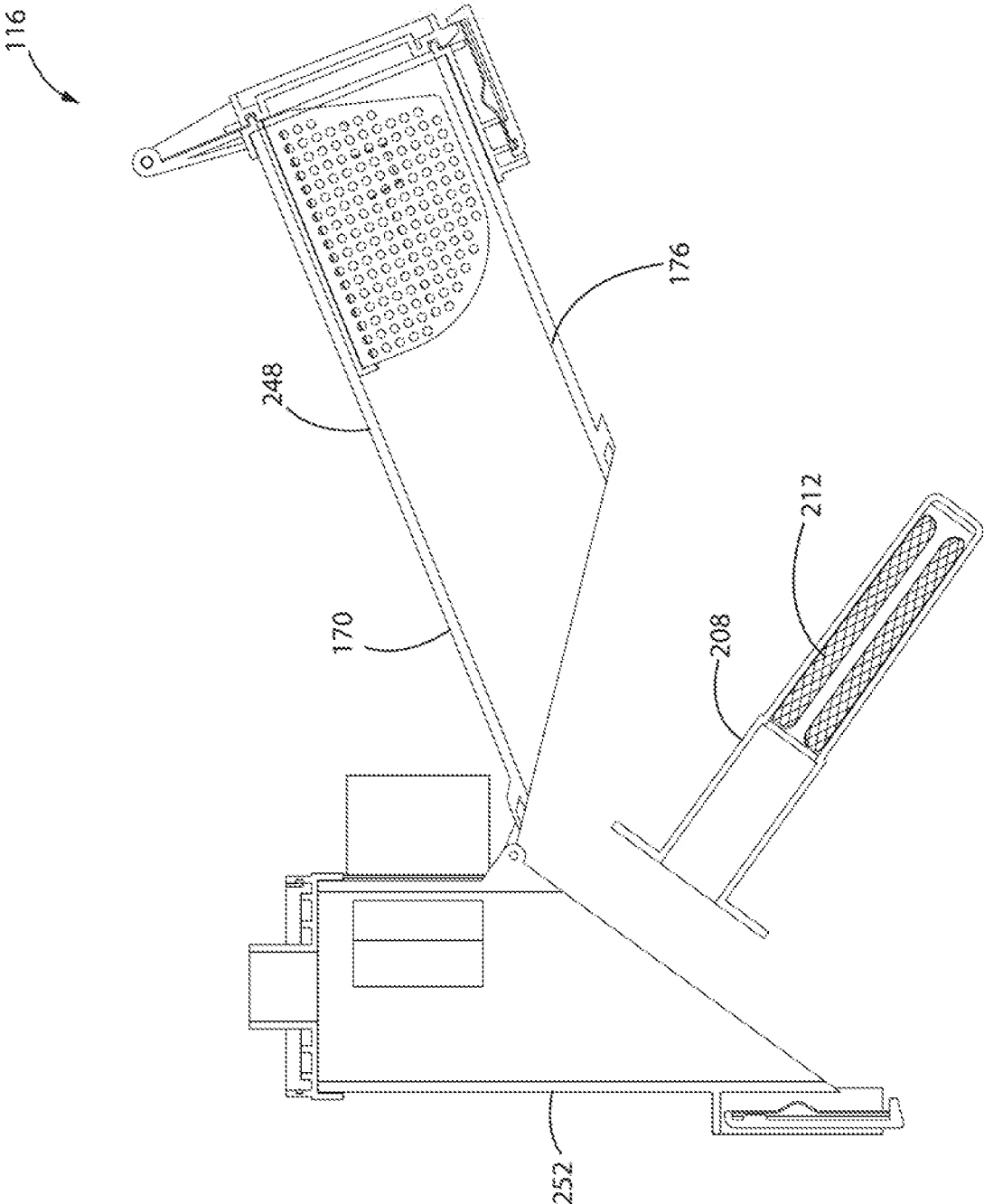

FIG. 12

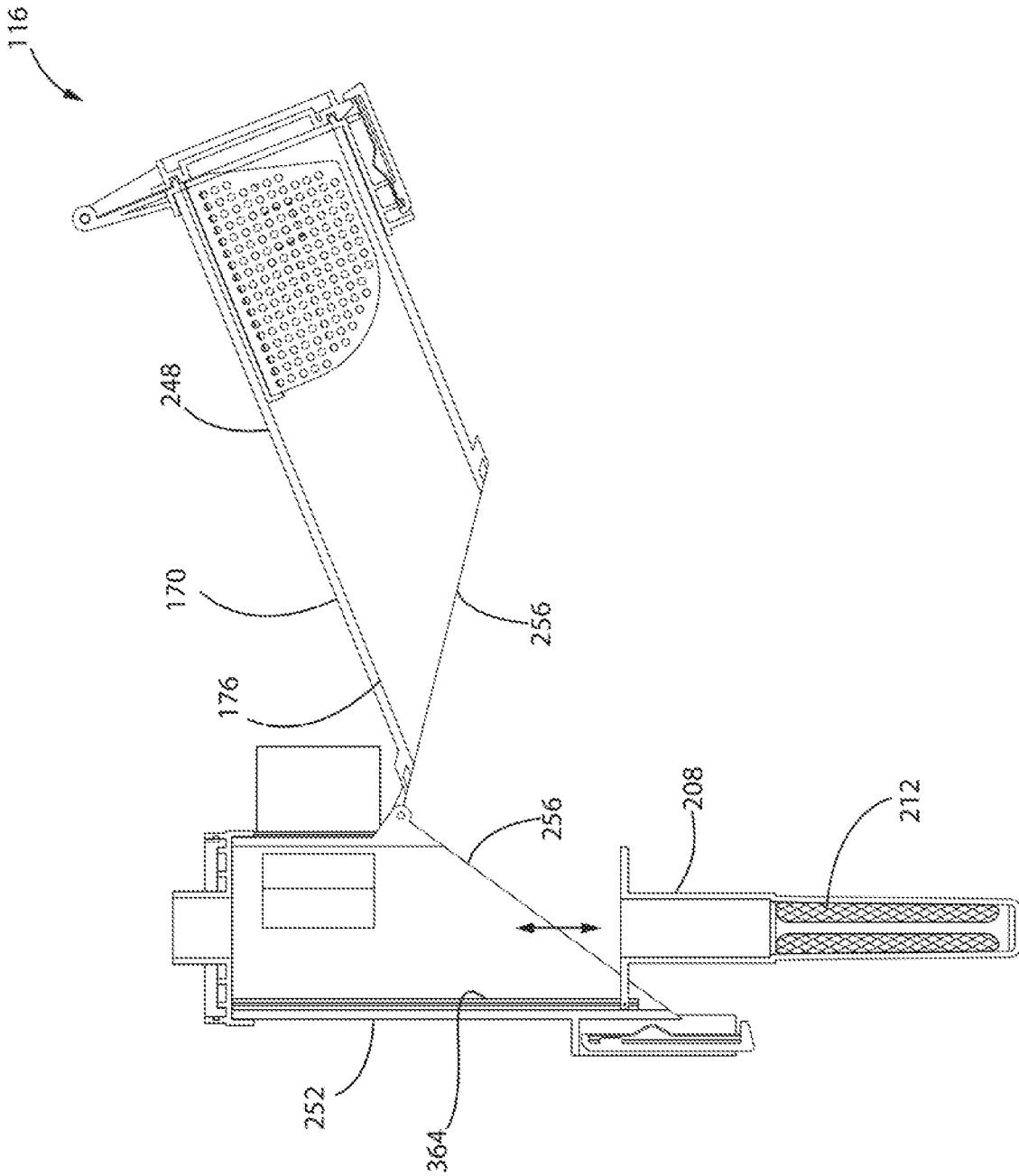

FIG. 13

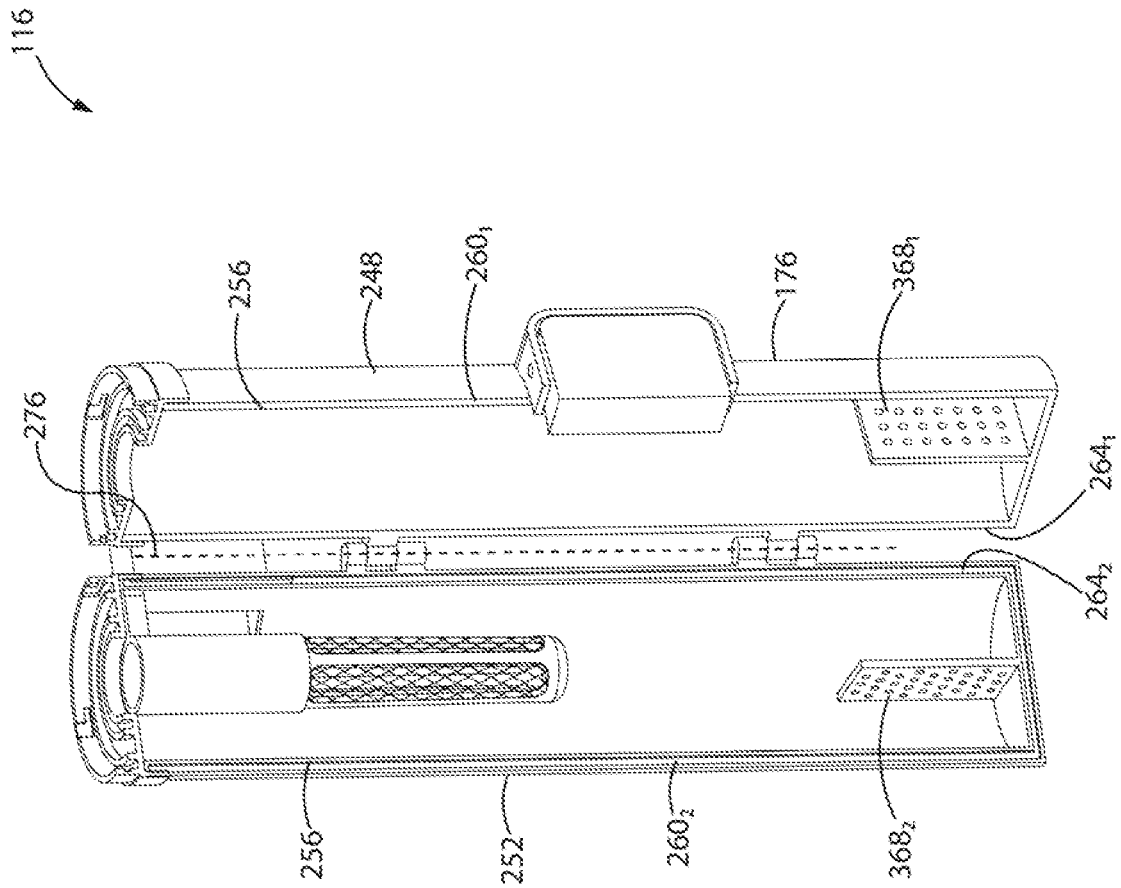

FIG. 14

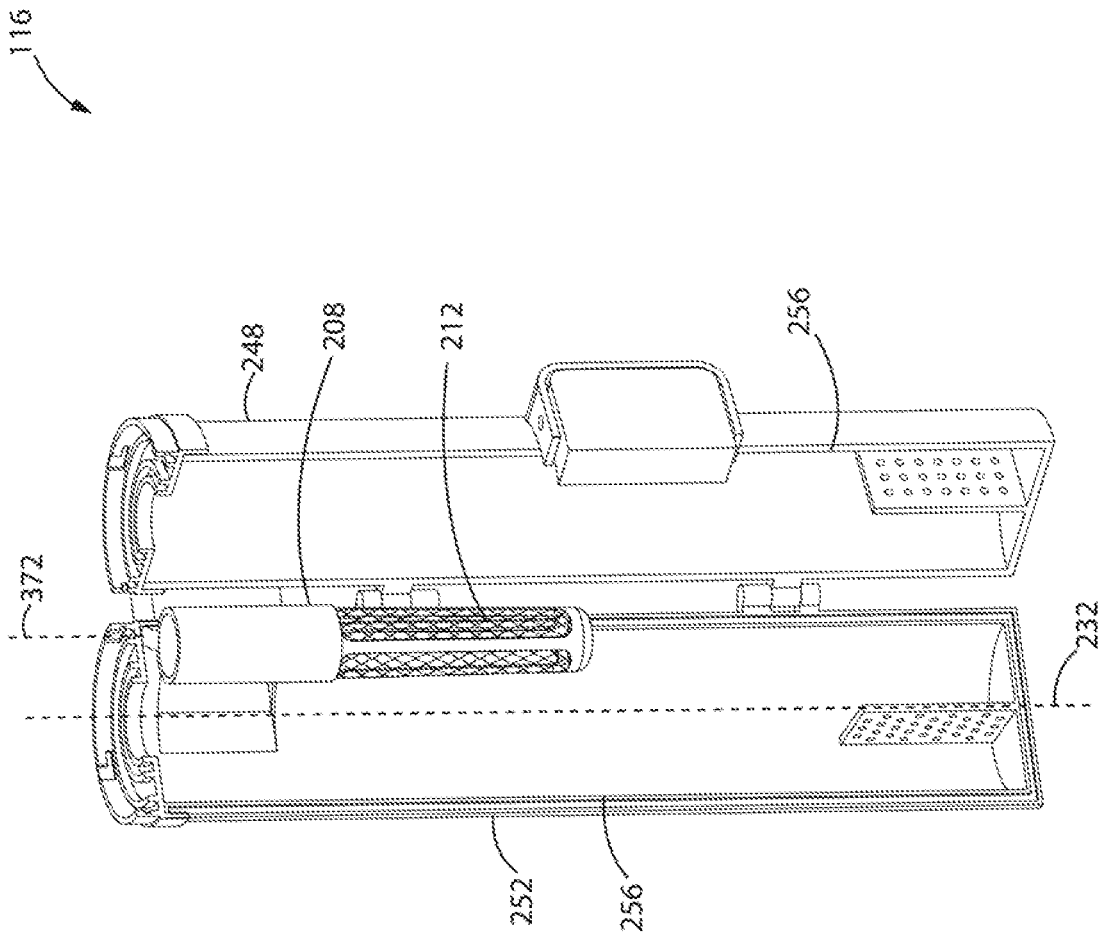

FIG. 15

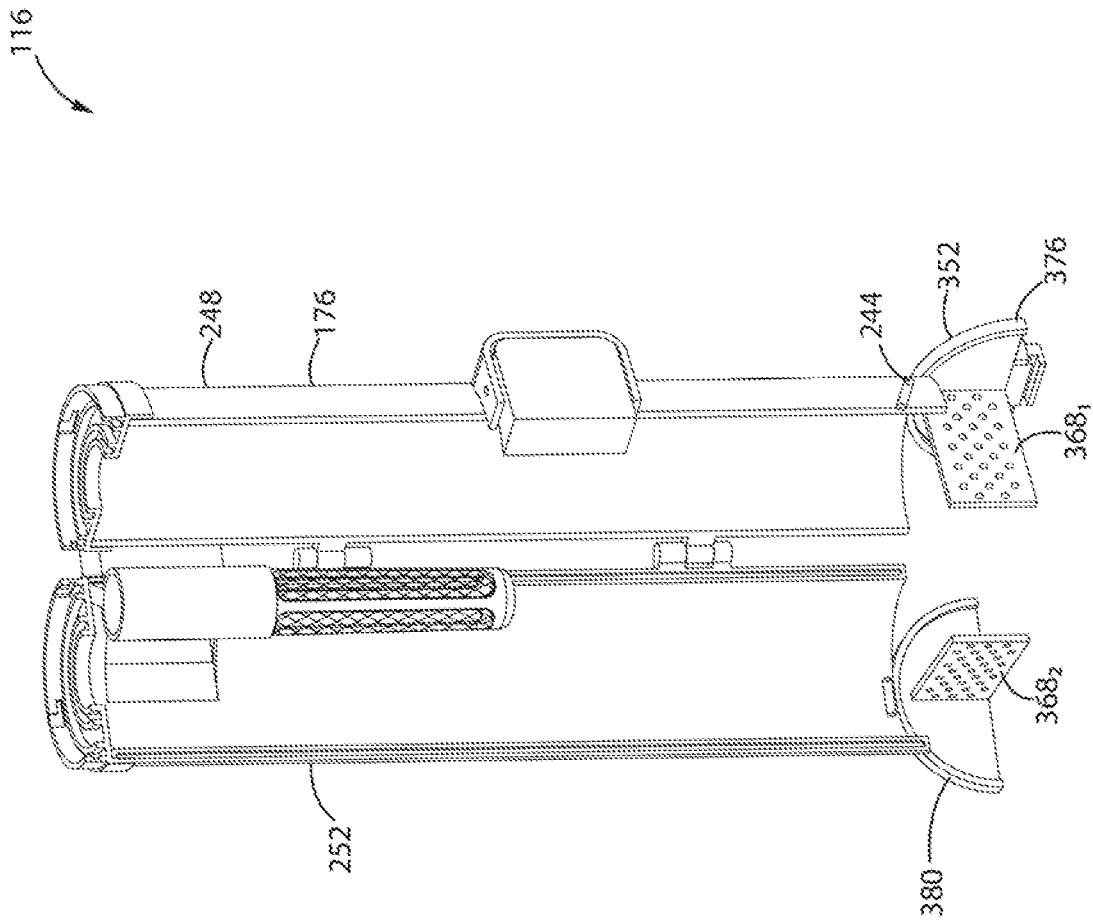

FIG. 16

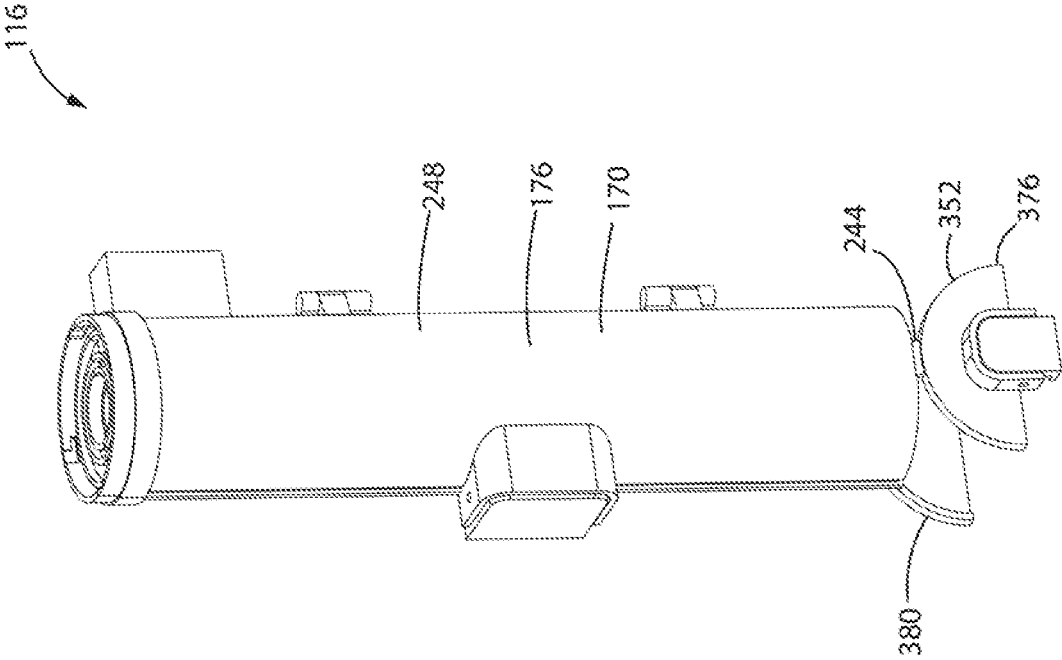

FIG. 17

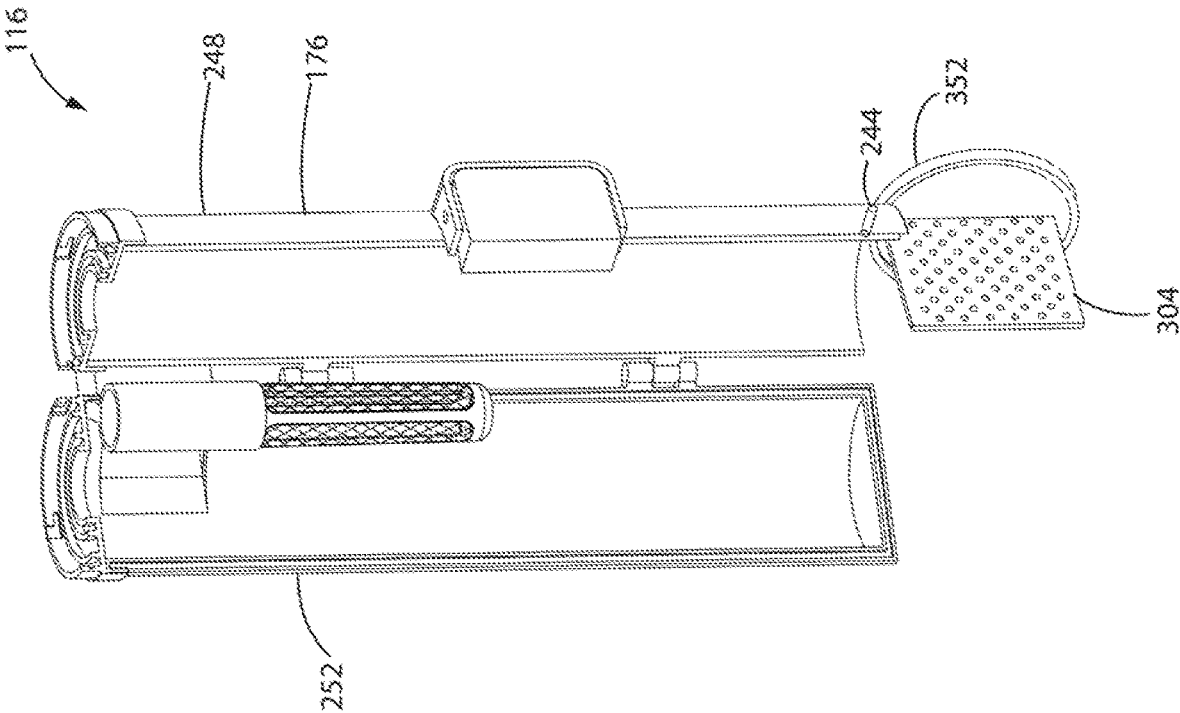

FIG. 18

116

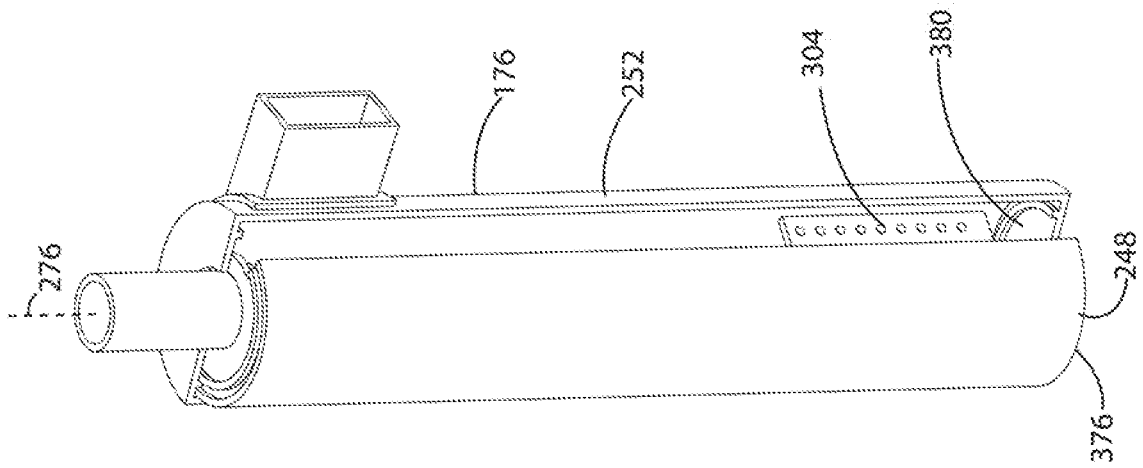

FIG. 19

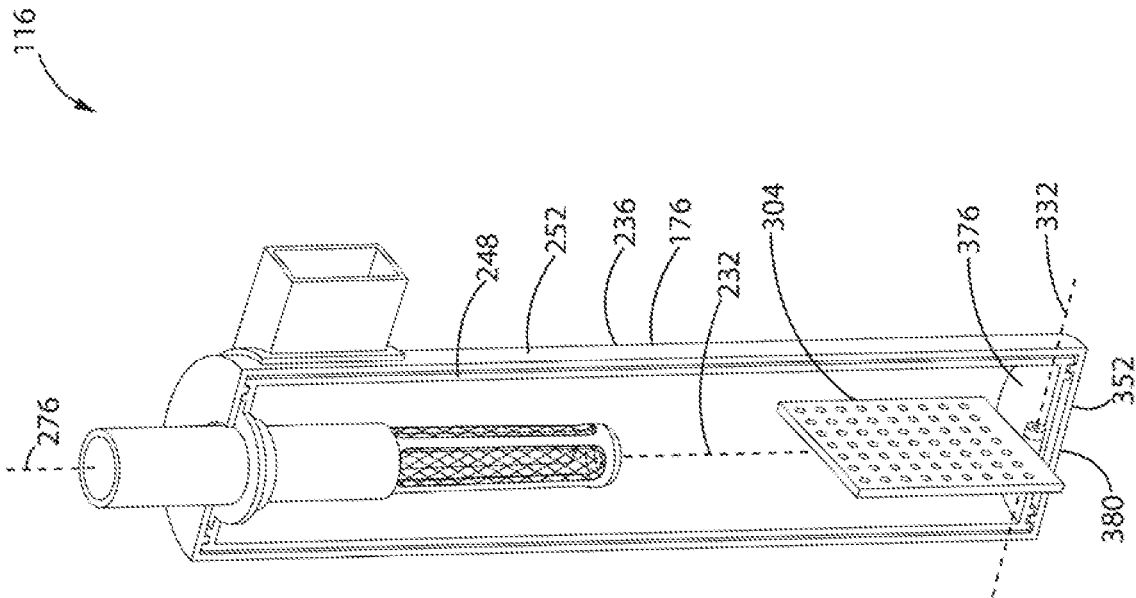

FIG. 20

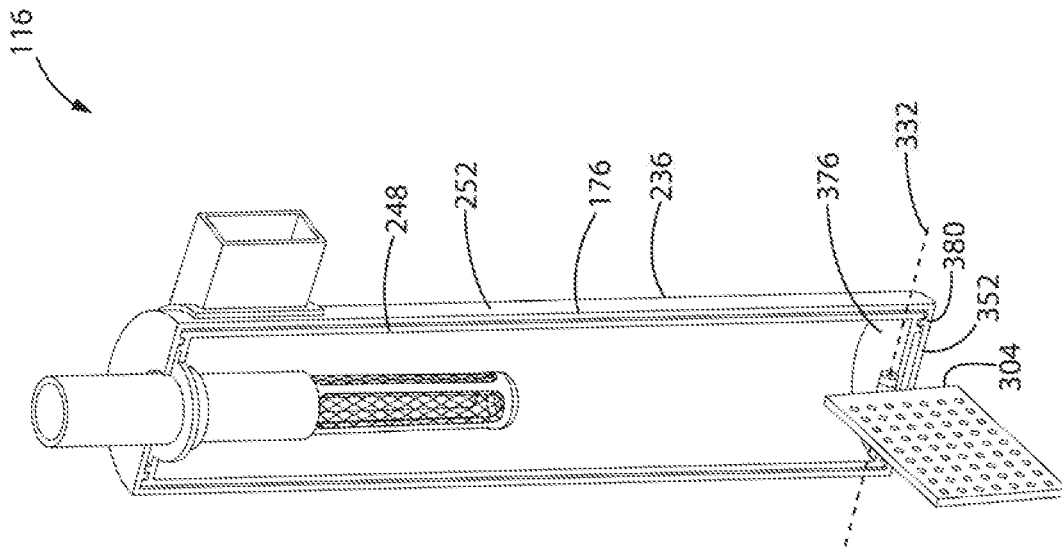

FIG. 21

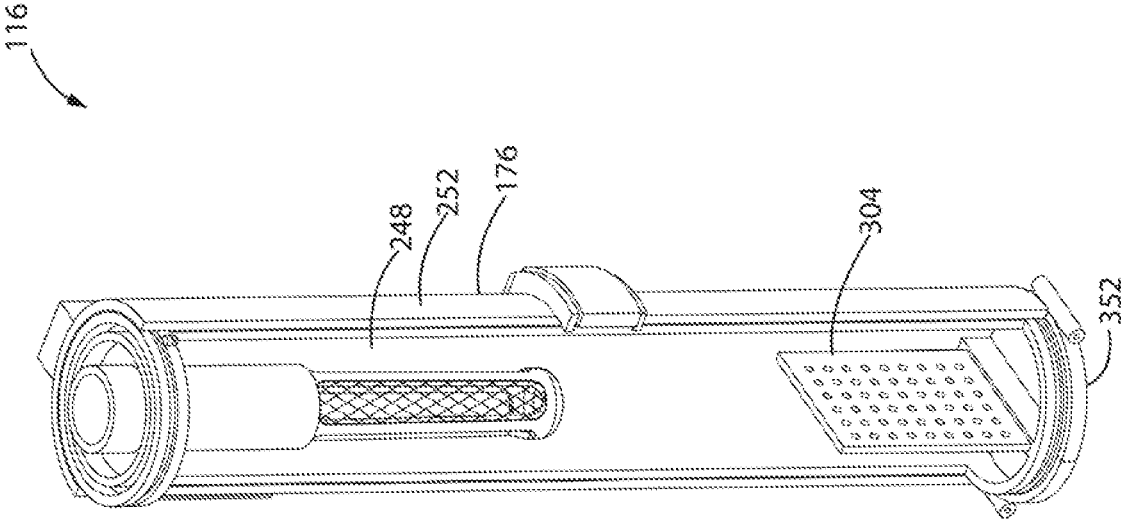

FIG. 22

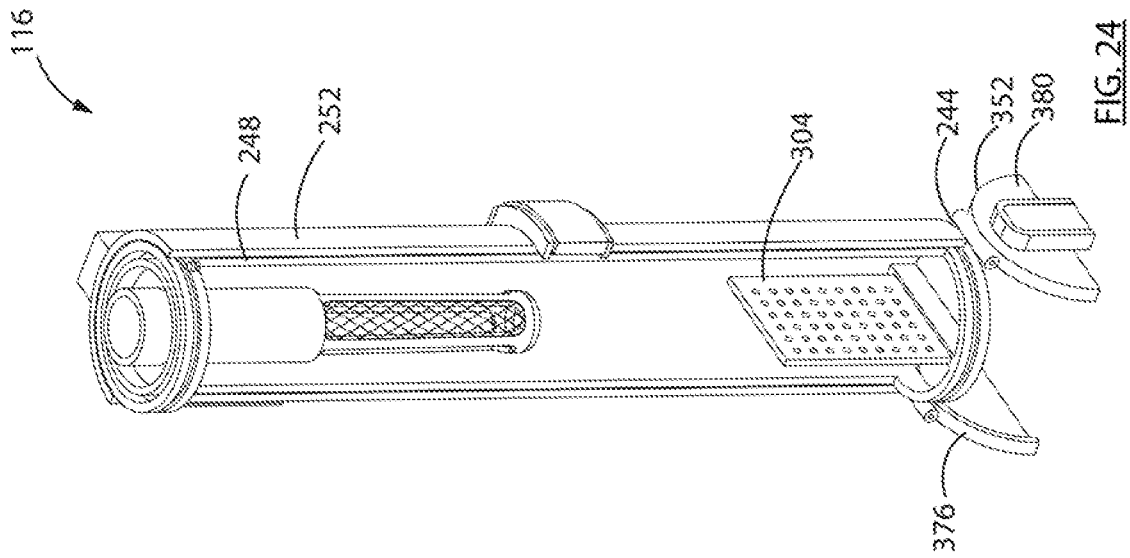

FIG. 24

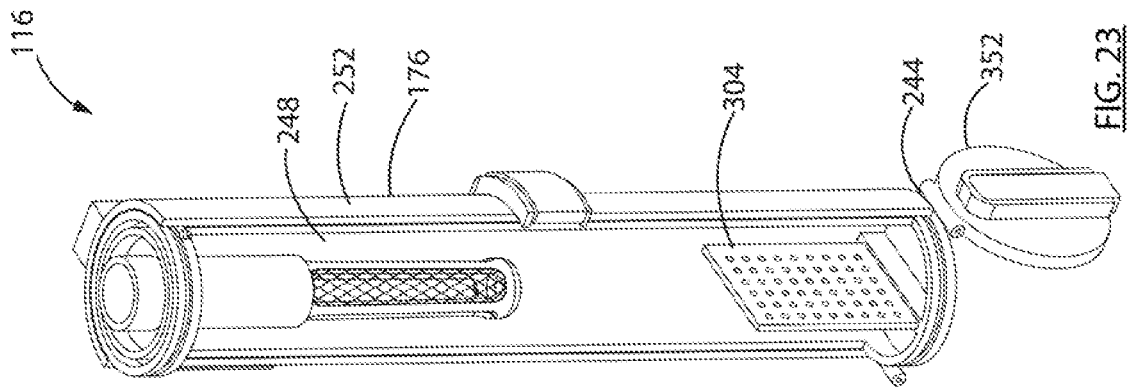

FIG. 23

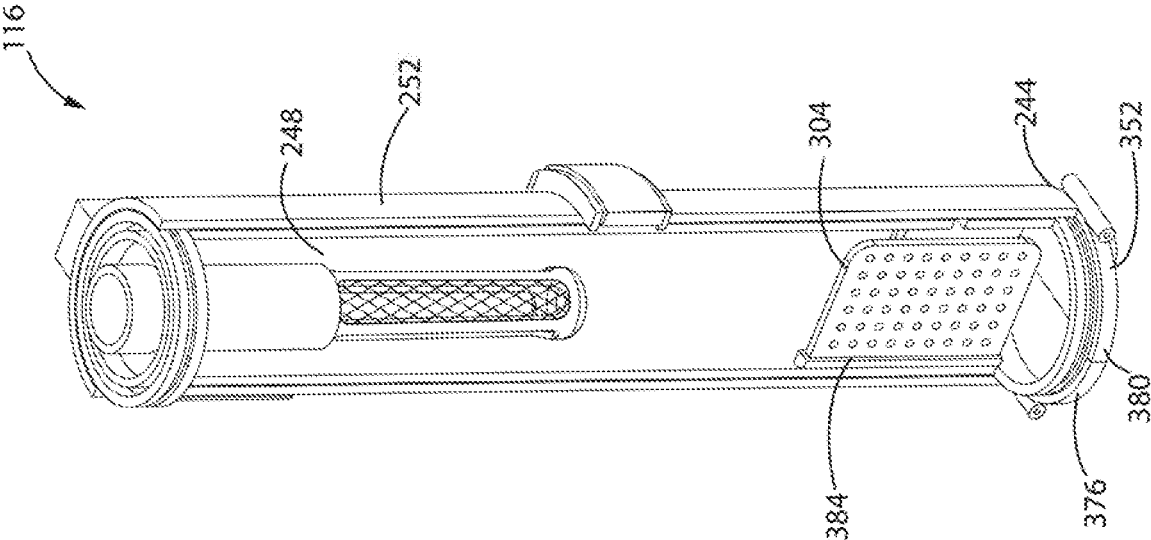

FIG. 25

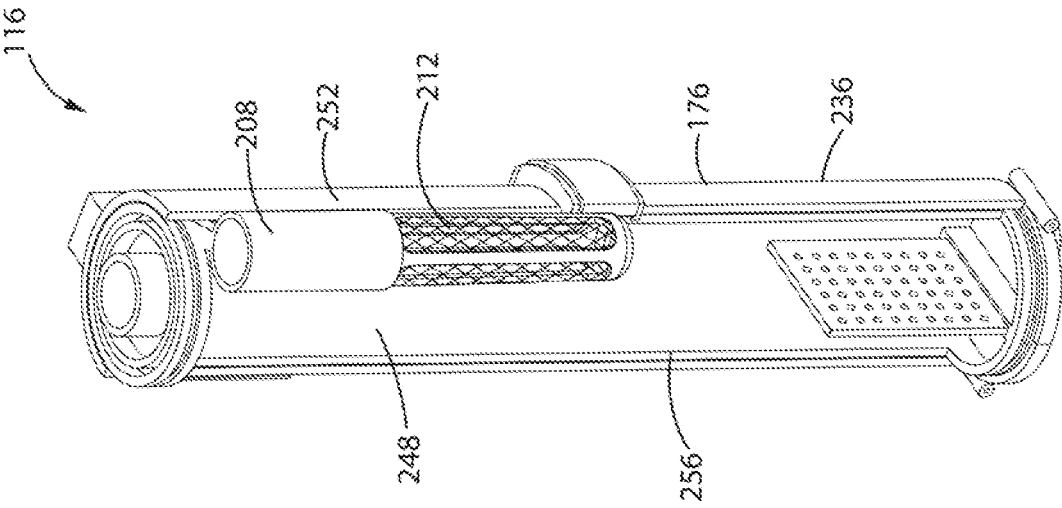

FIG. 26

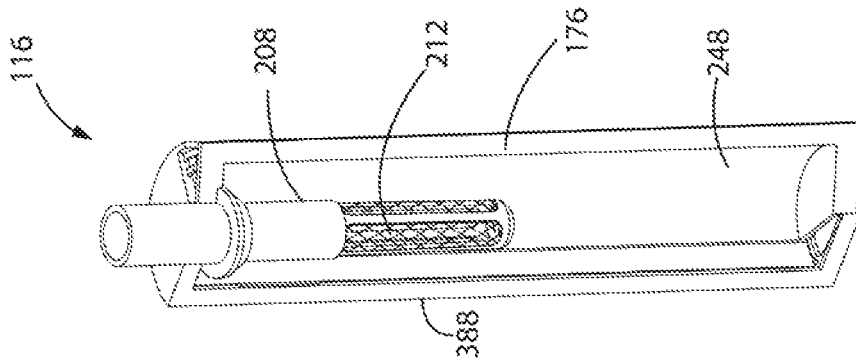

FIG. 27

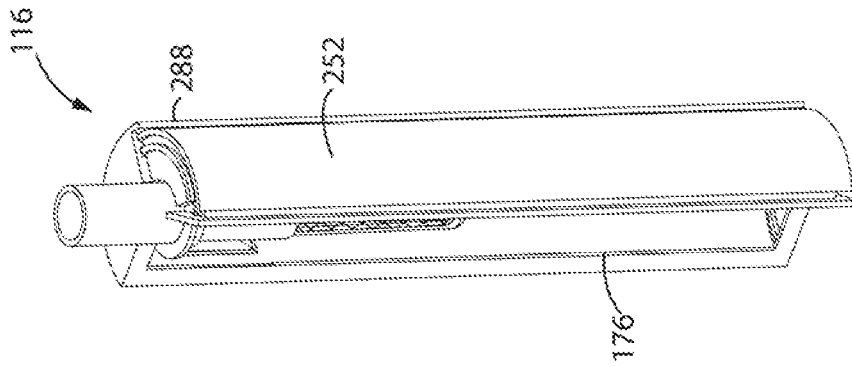

FIG. 28

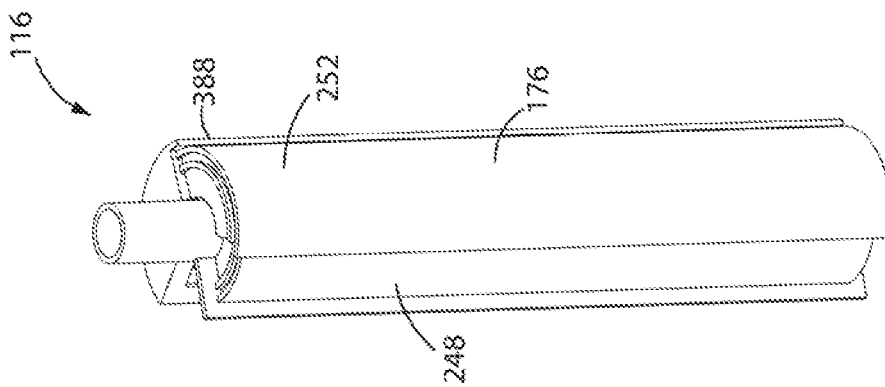

FIG. 29

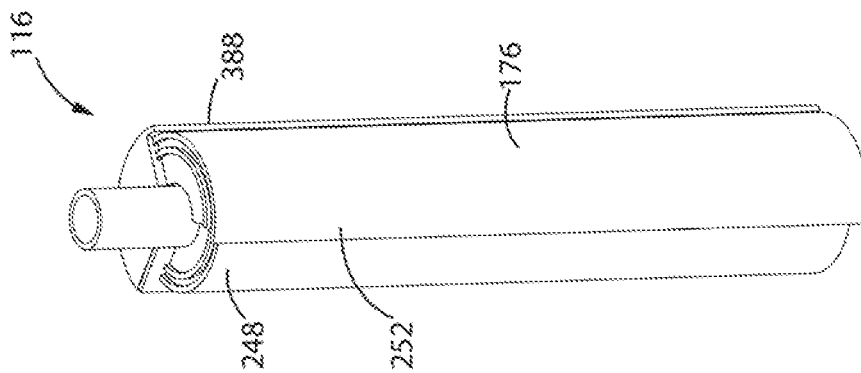

FIG. 30

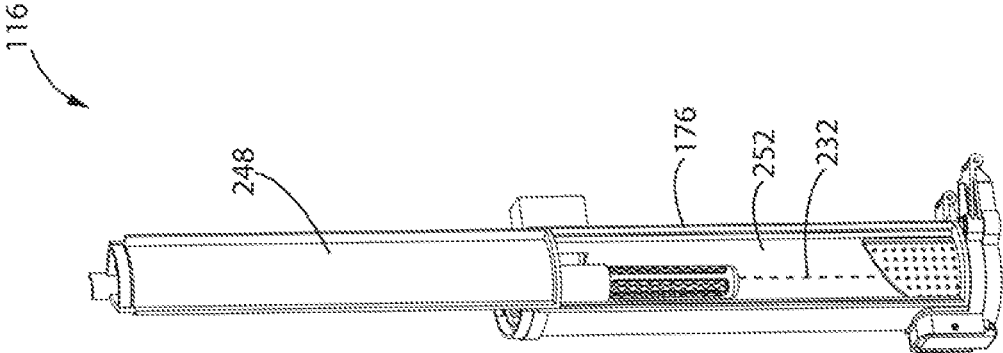

FIG. 31

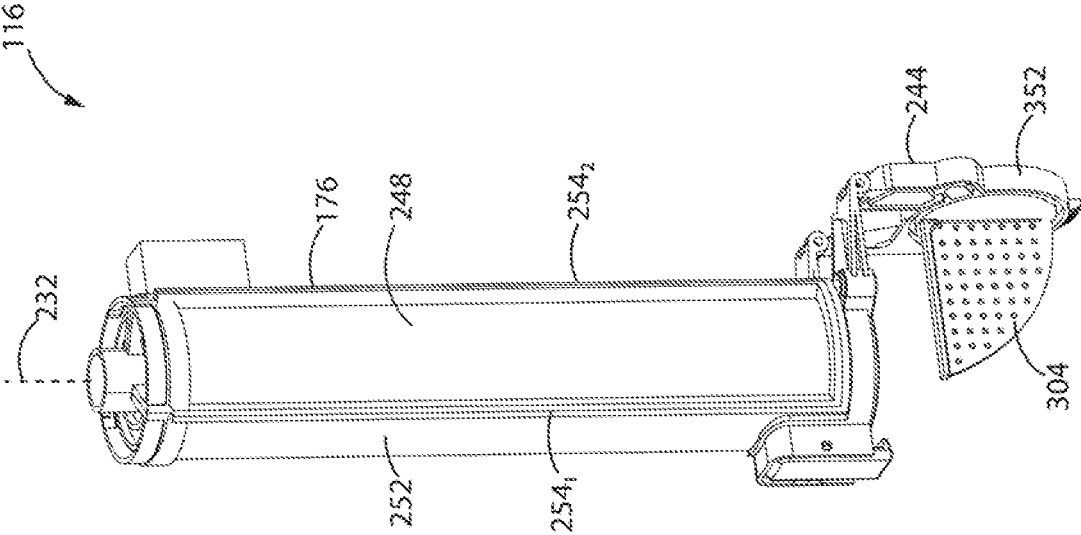

FIG. 32

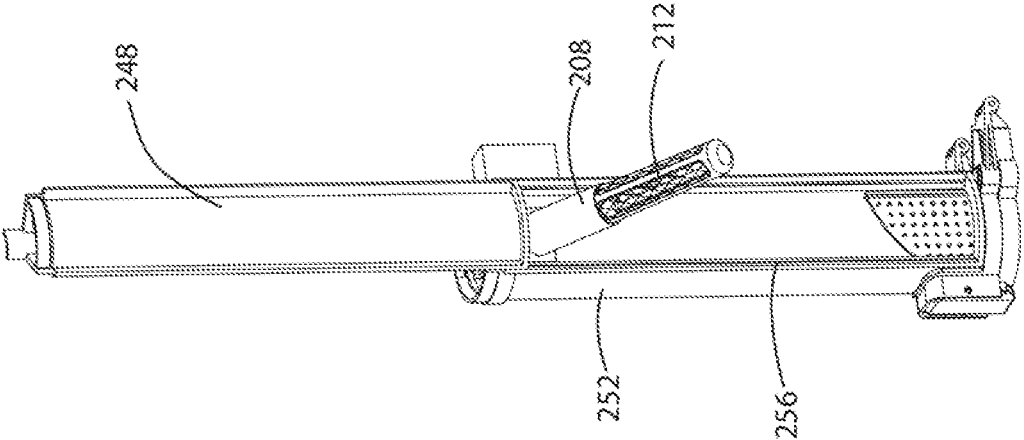

FIG. 33

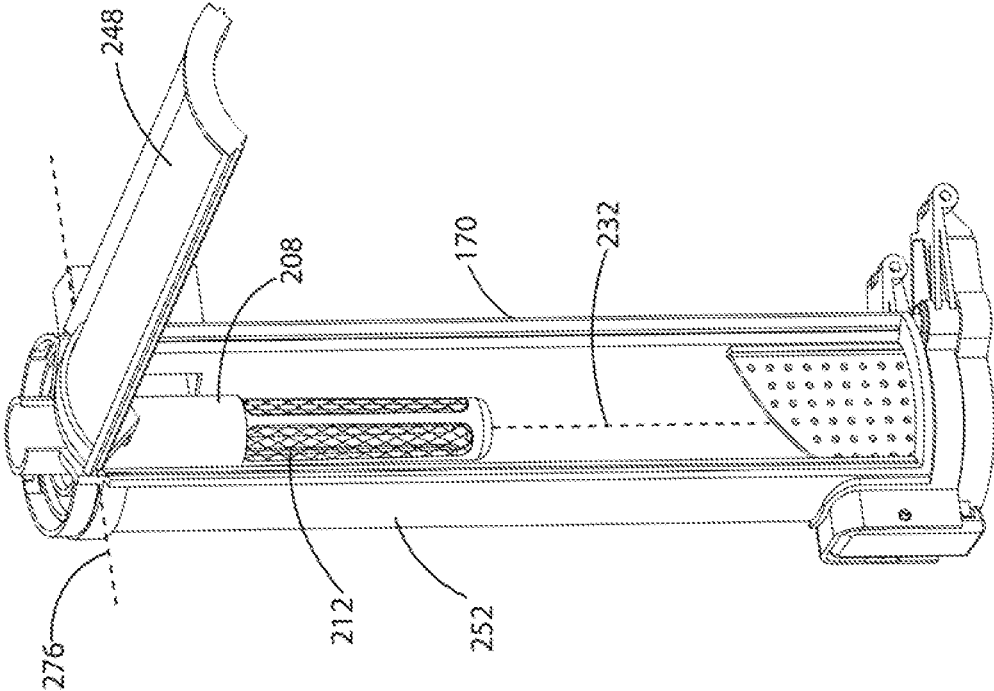
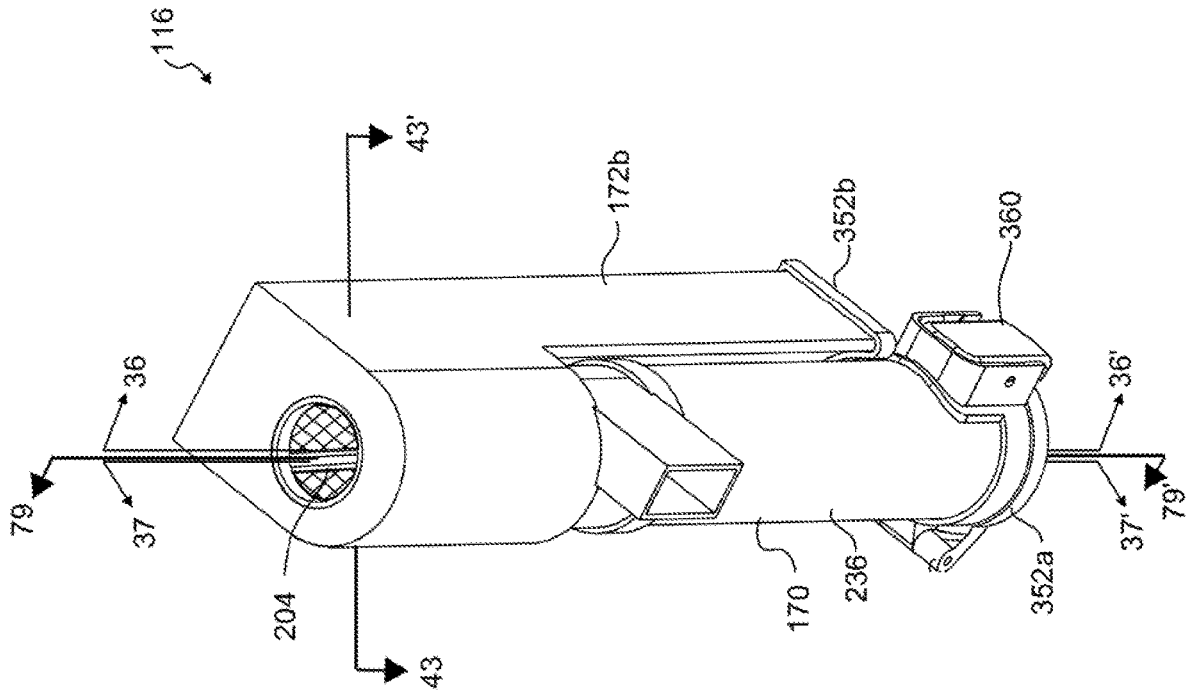

FIG. 34



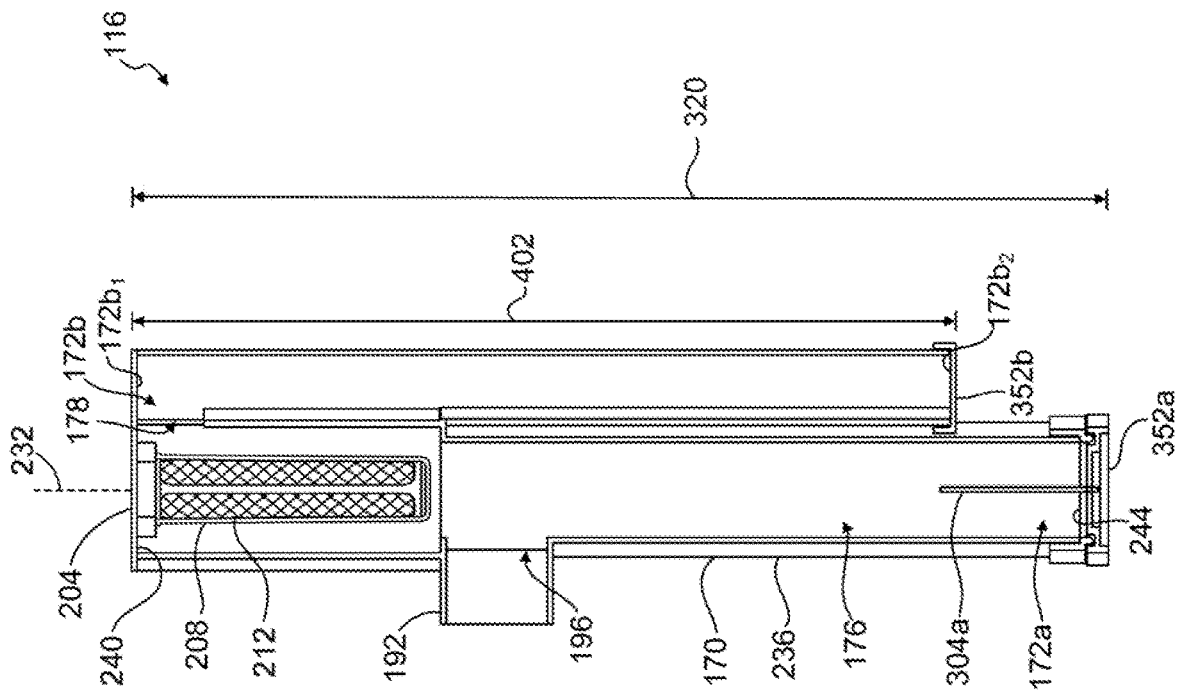

FIG. 36

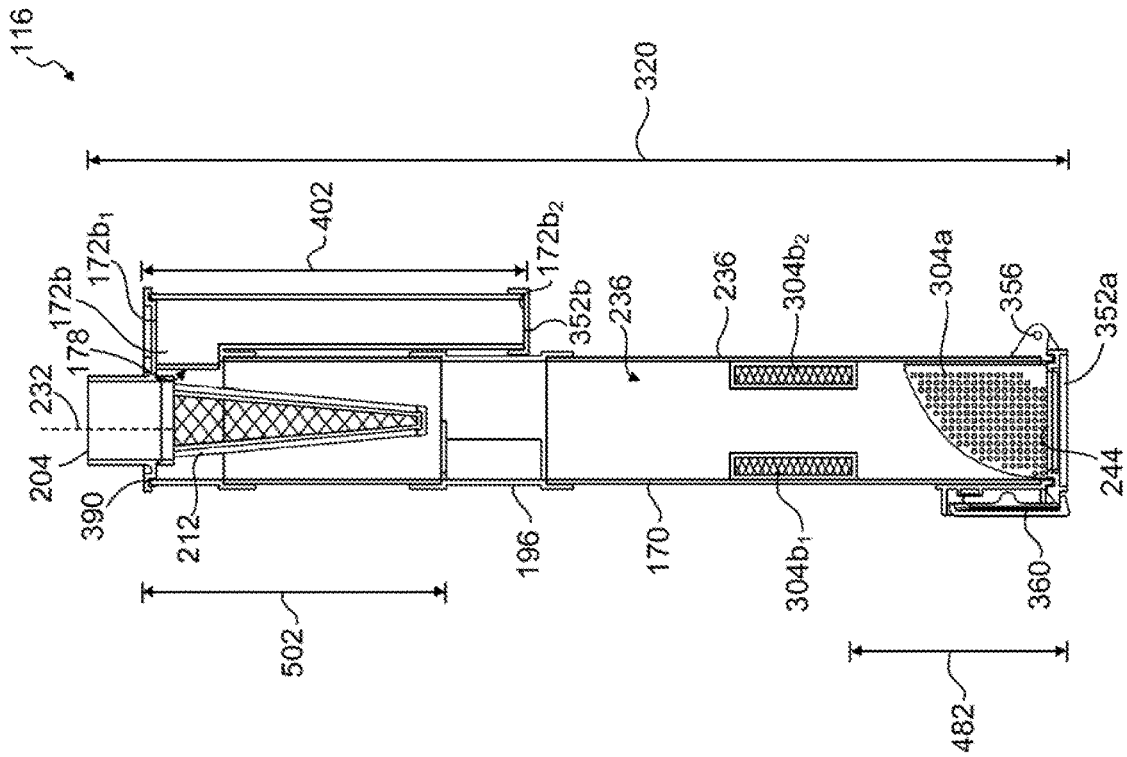

FIG. 37

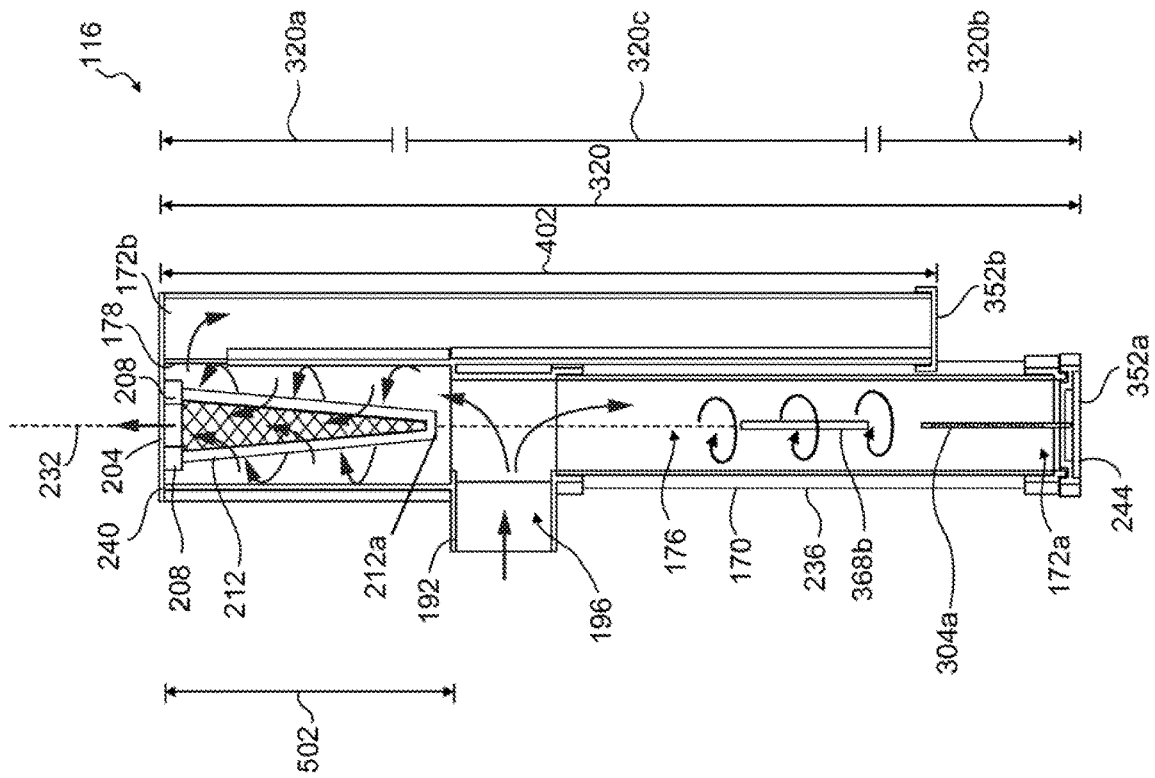

FIG. 38

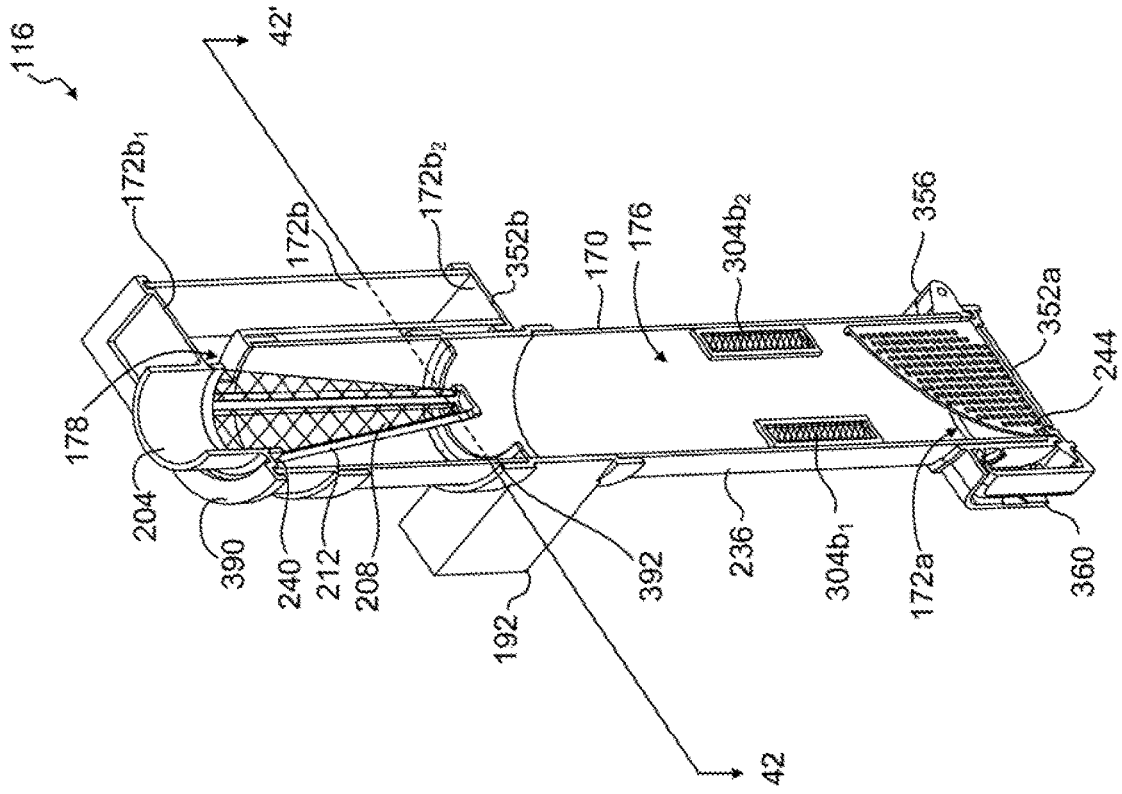

FIG. 39

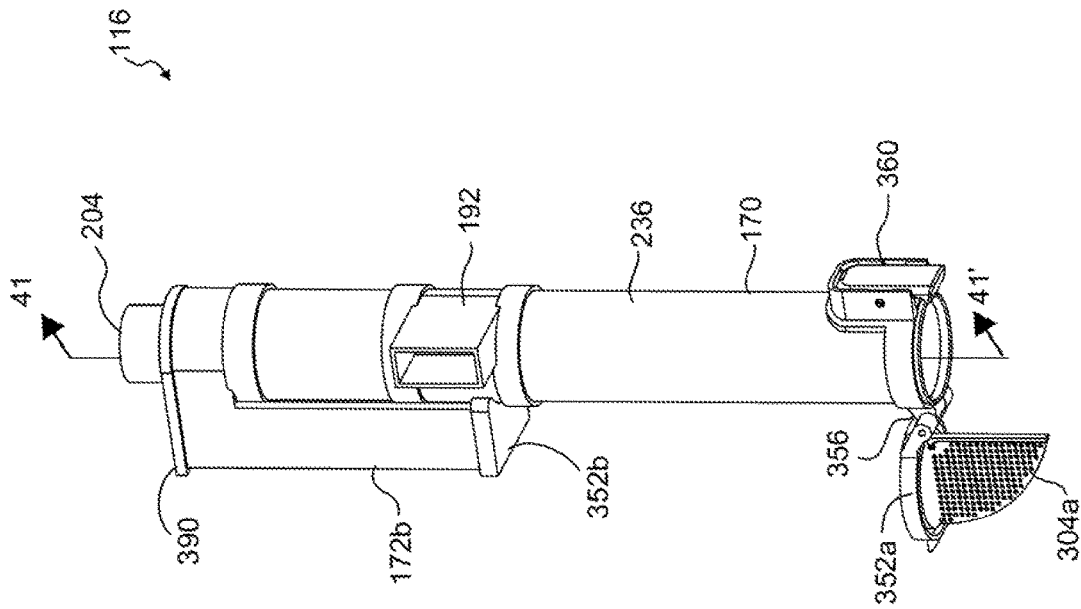

FIG. 40

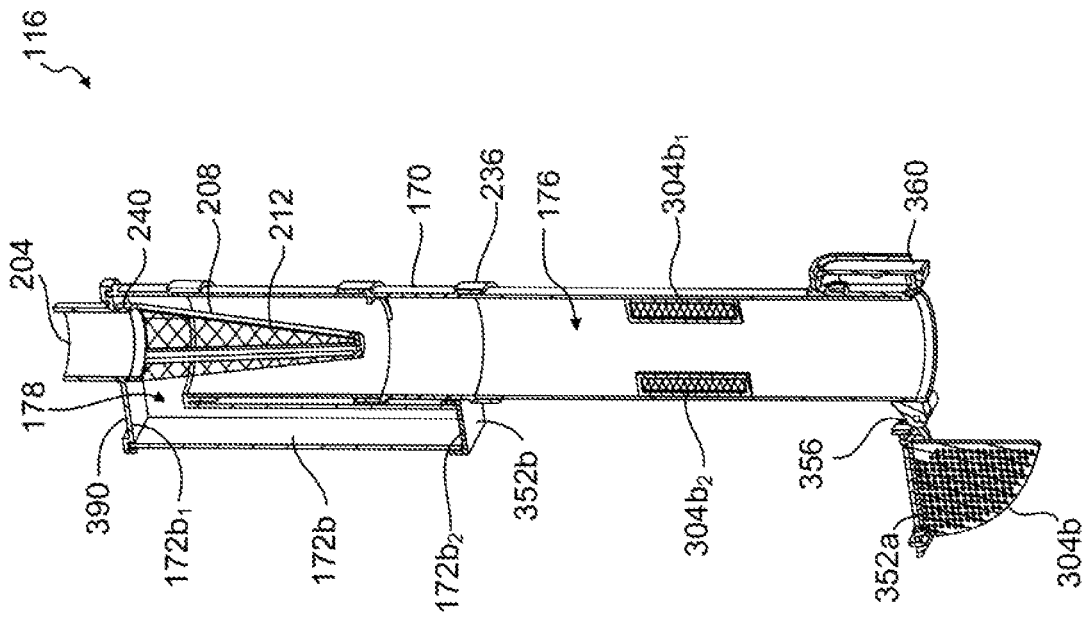

FIG. 41

116

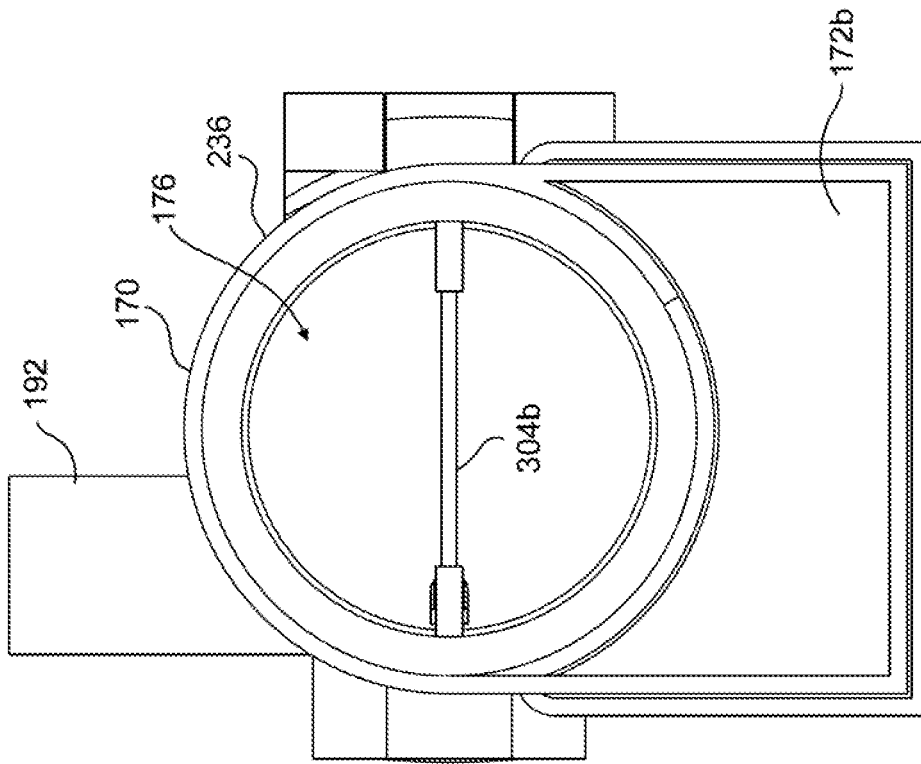

FIG. 42

116

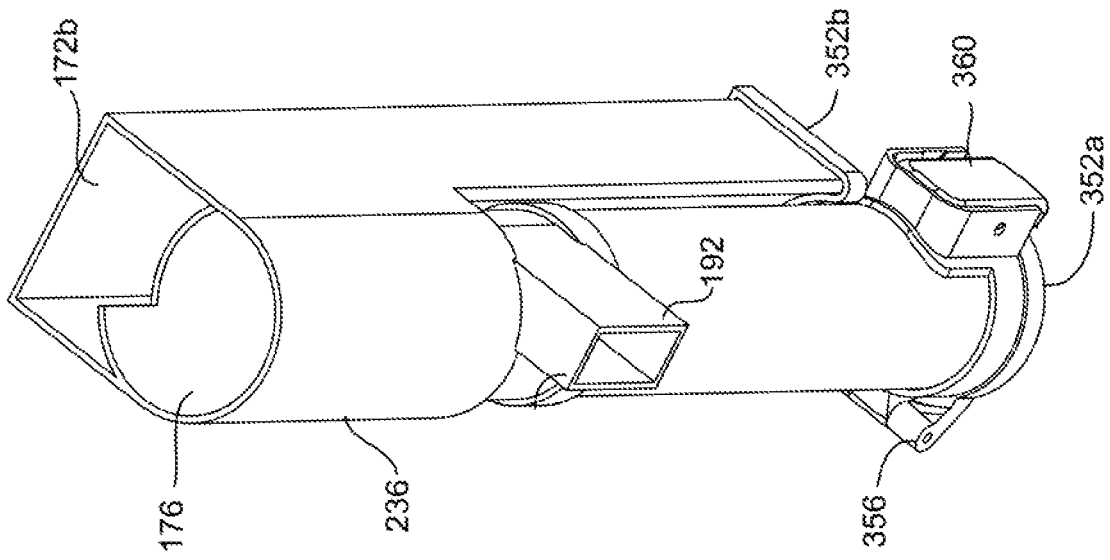

FIG. 43

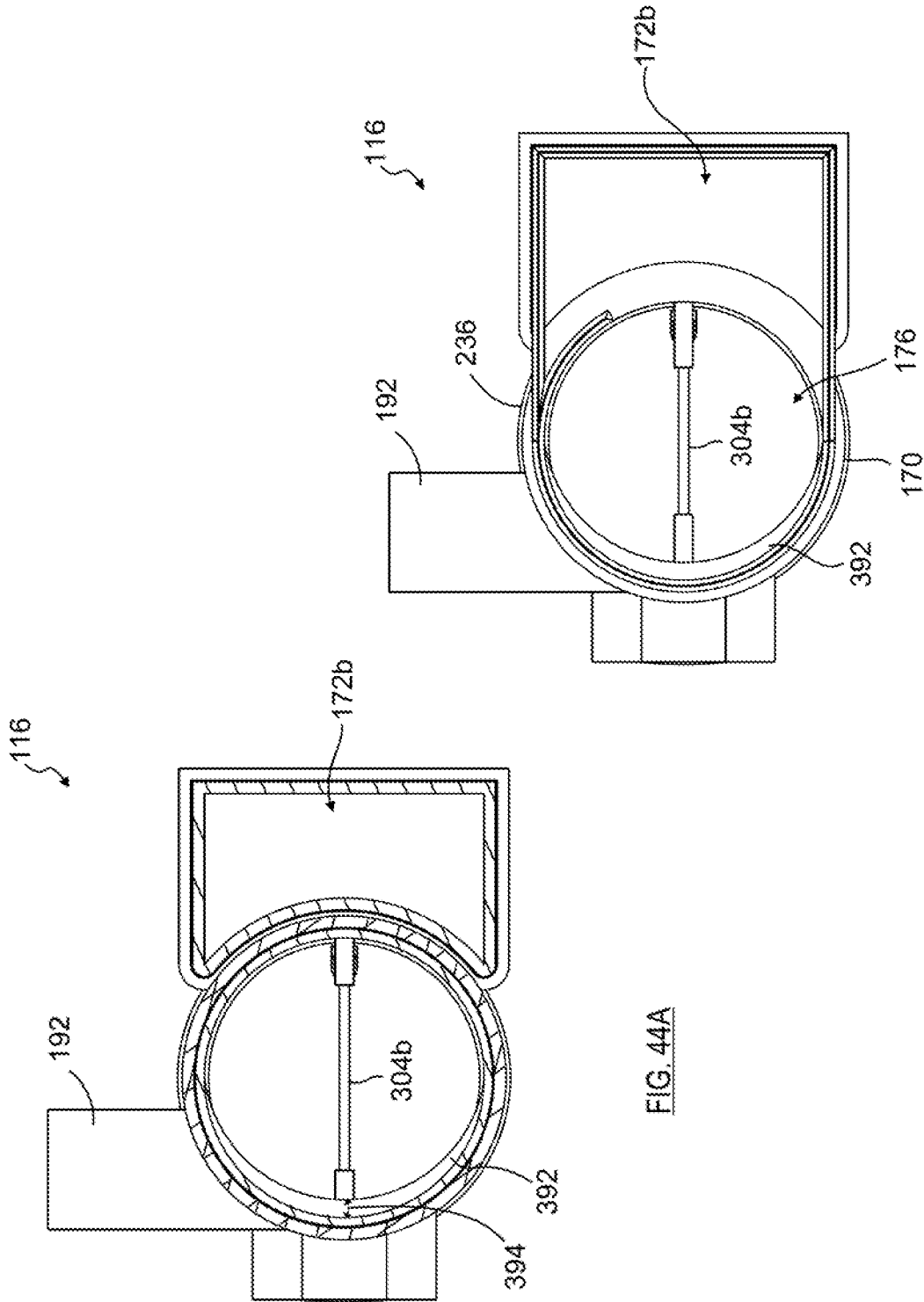
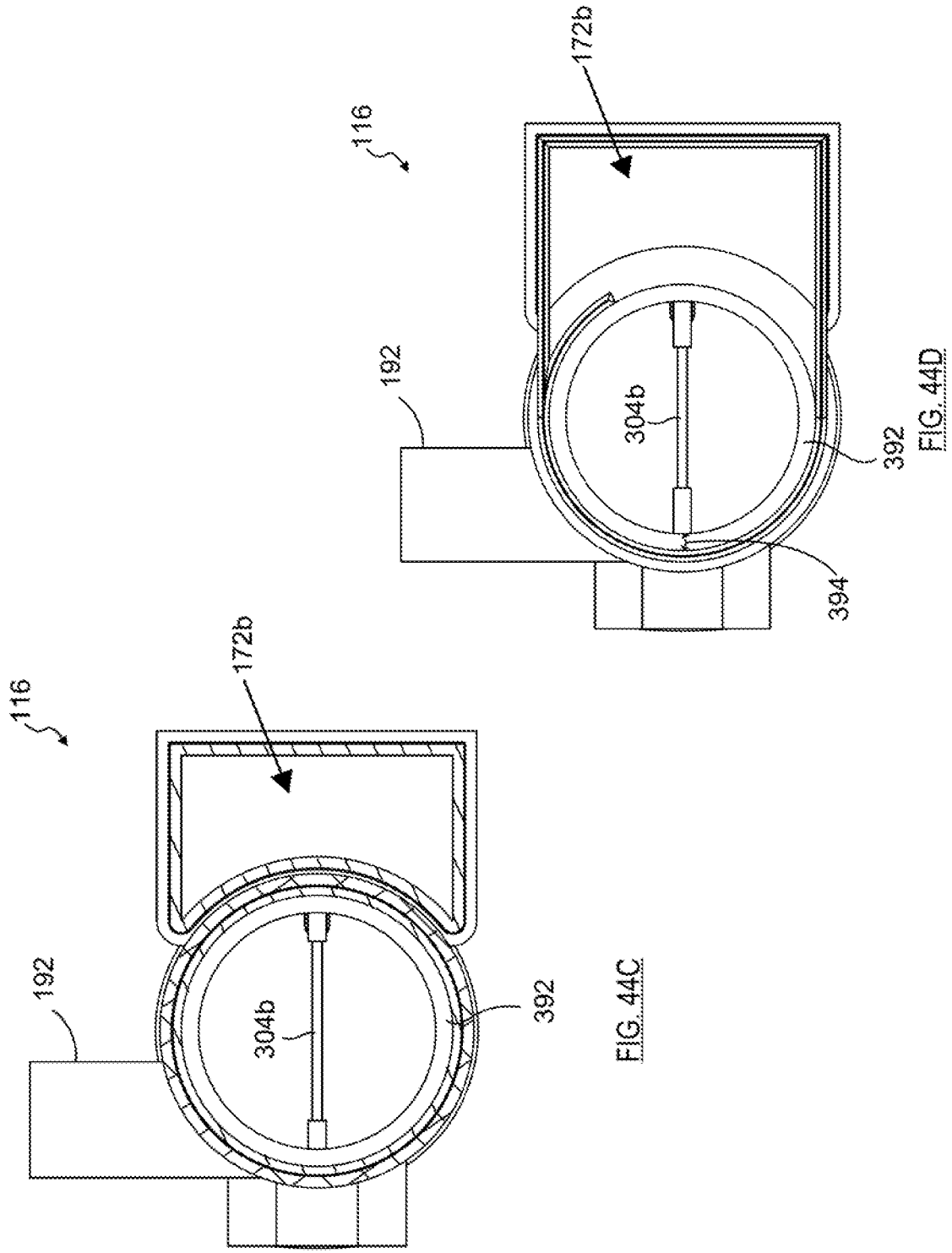

FIG. 44A

FIG. 44B



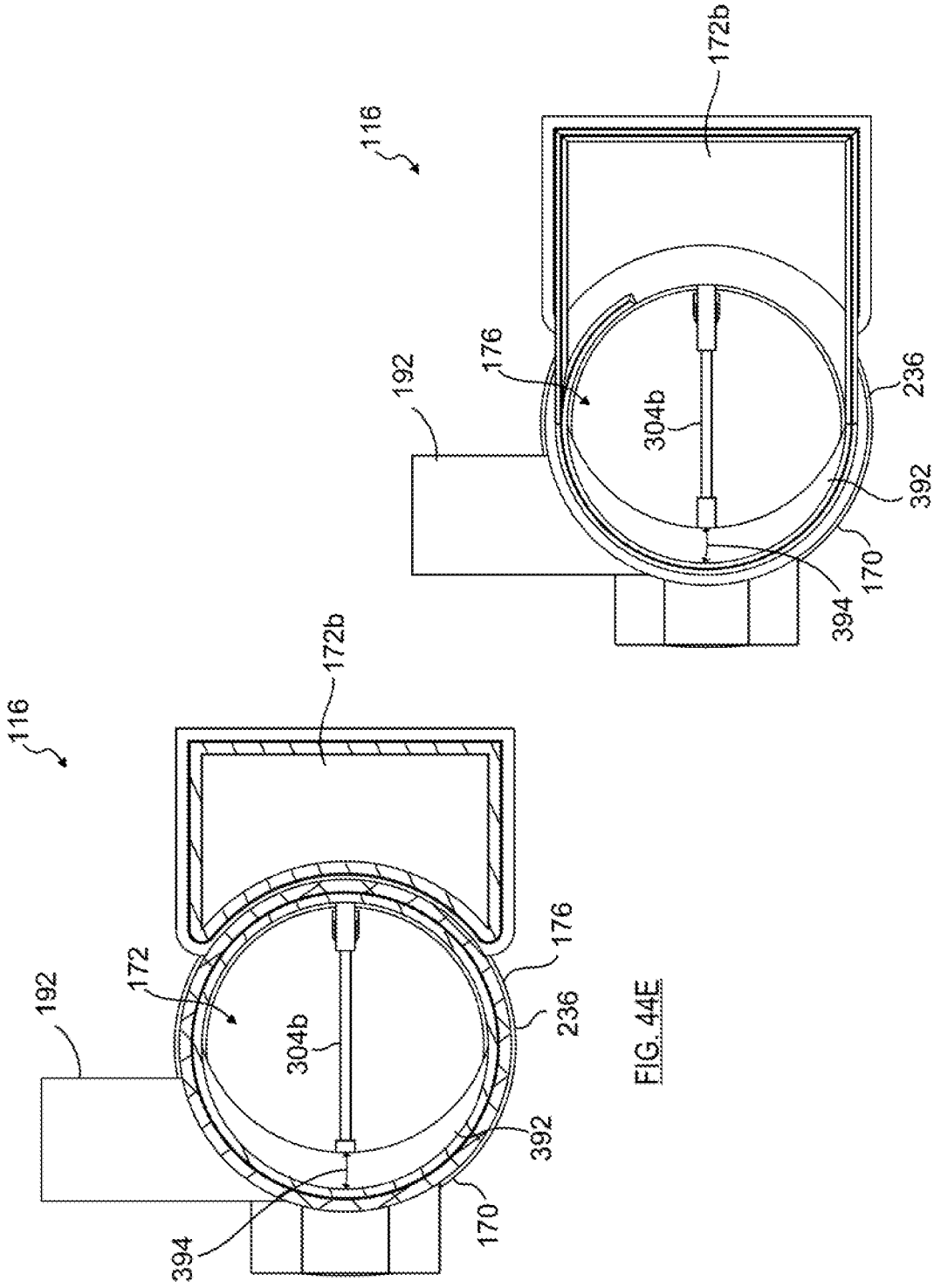

FIG. 44E

FIG. 44F

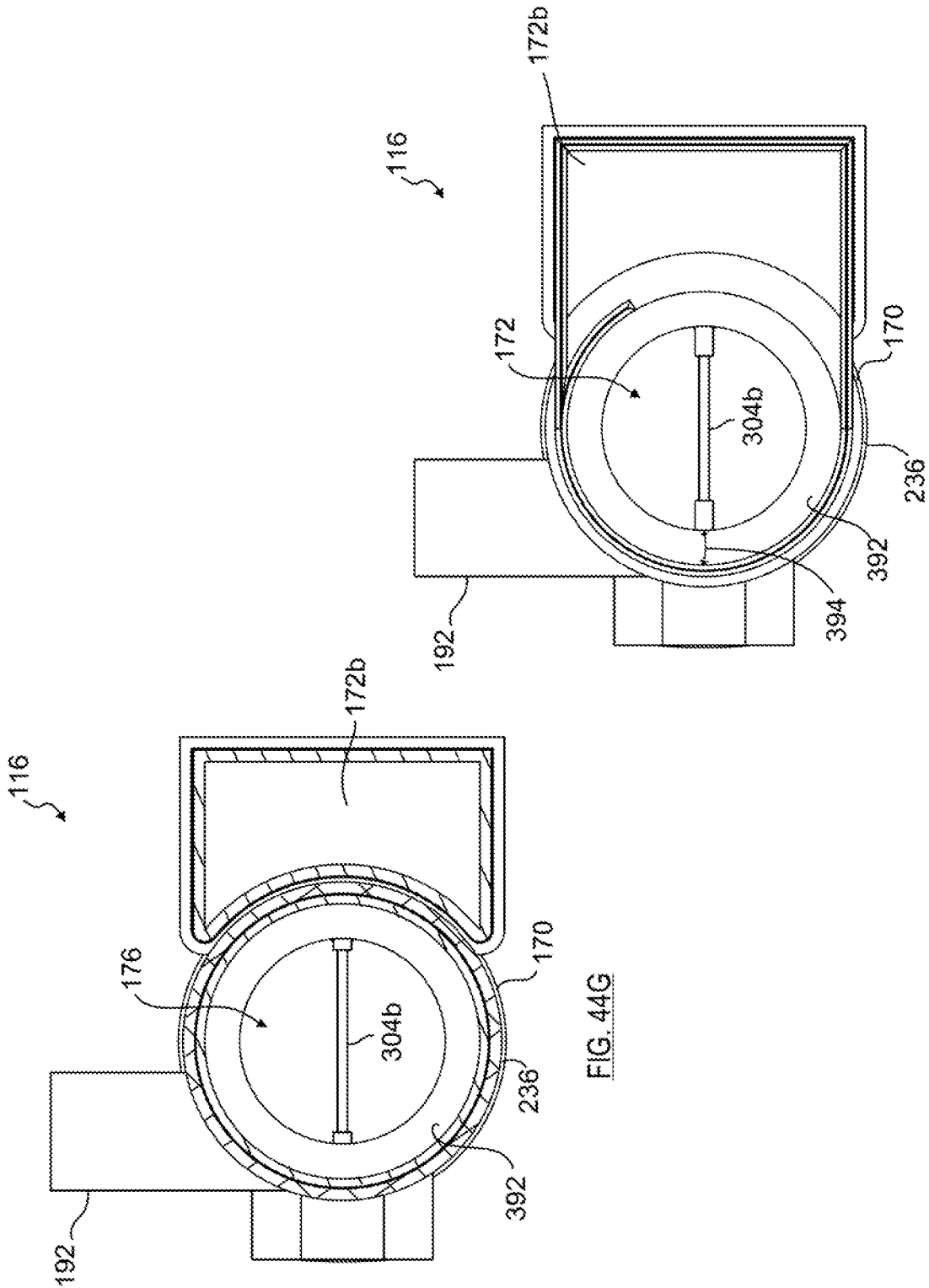

FIG. 44G

FIG. 44H

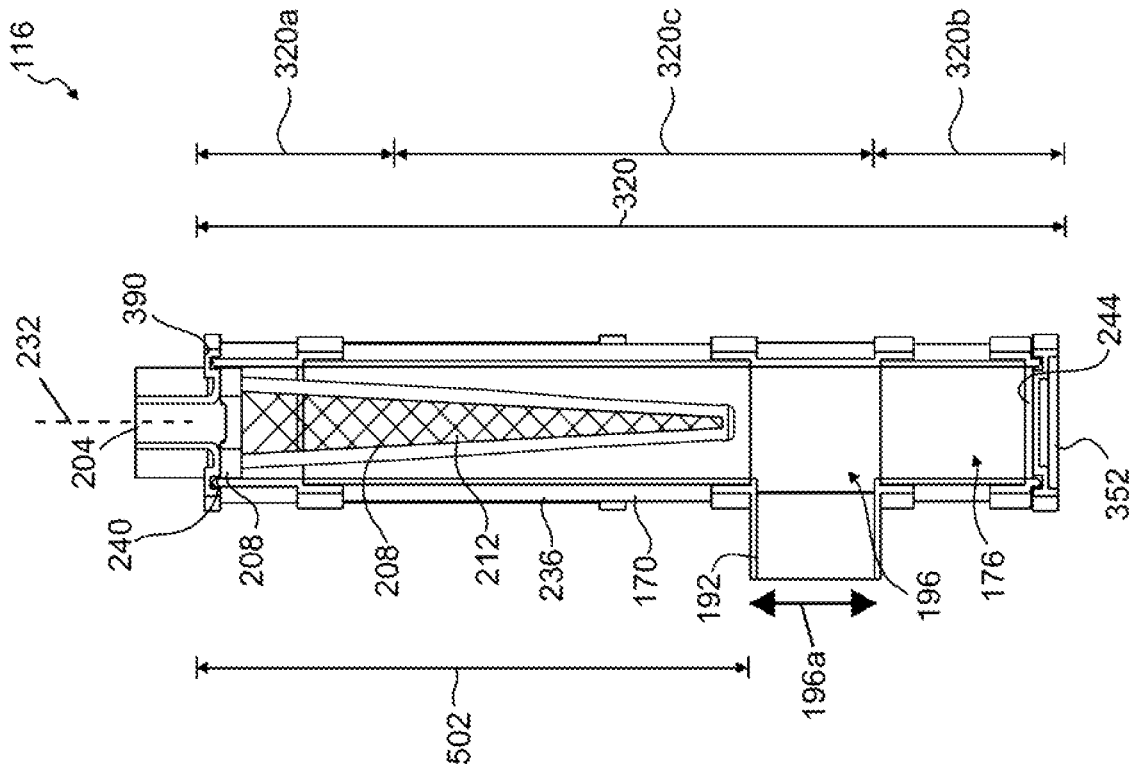

FIG. 45

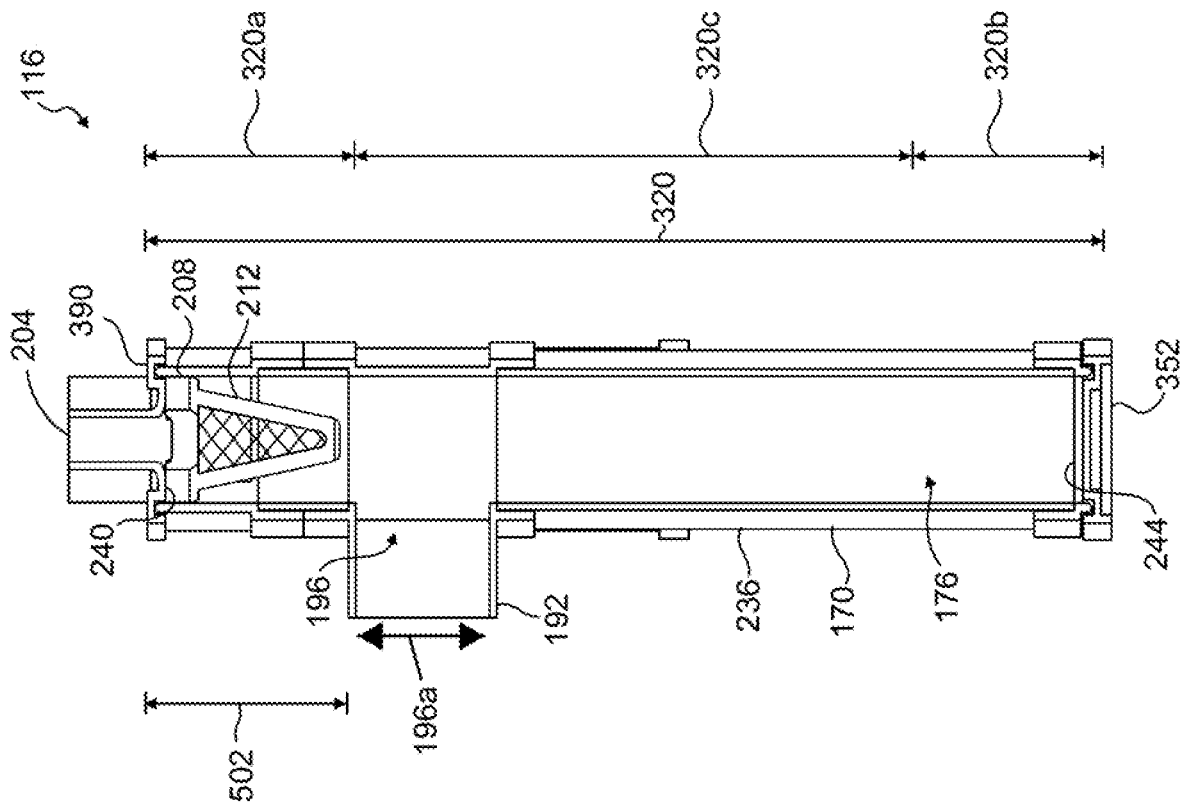
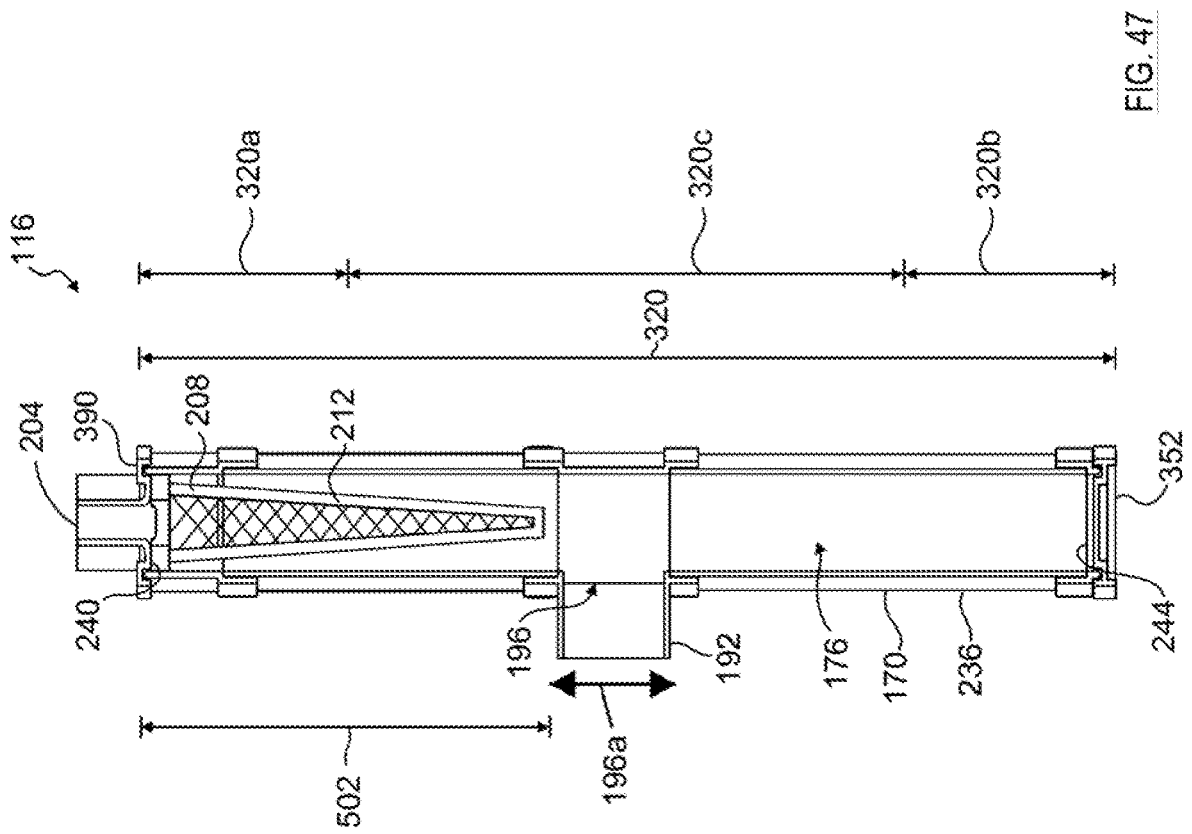

FIG. 46



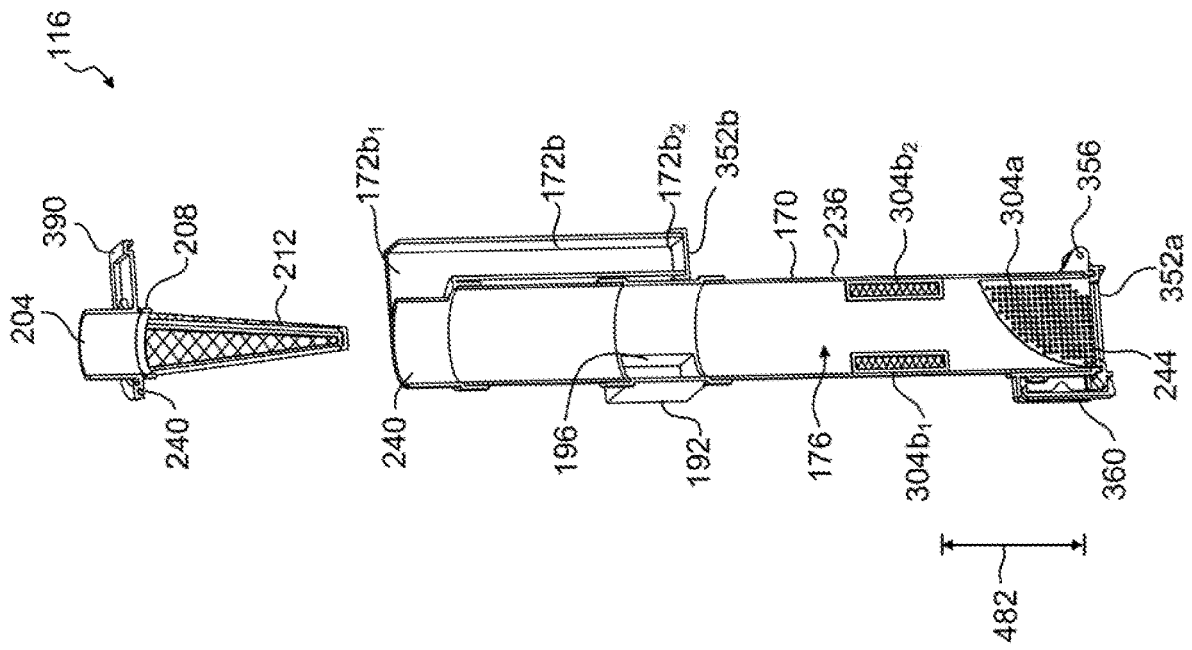

FIG. 48

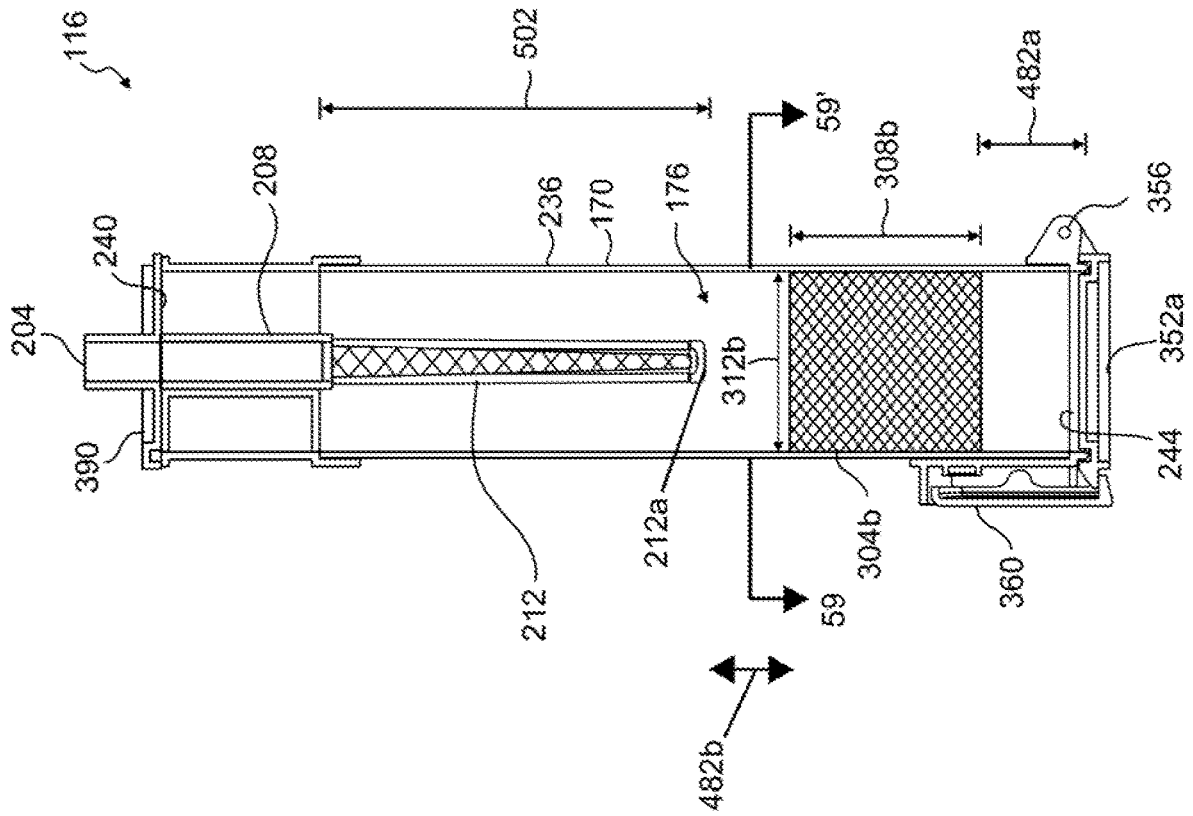

FIG. 49

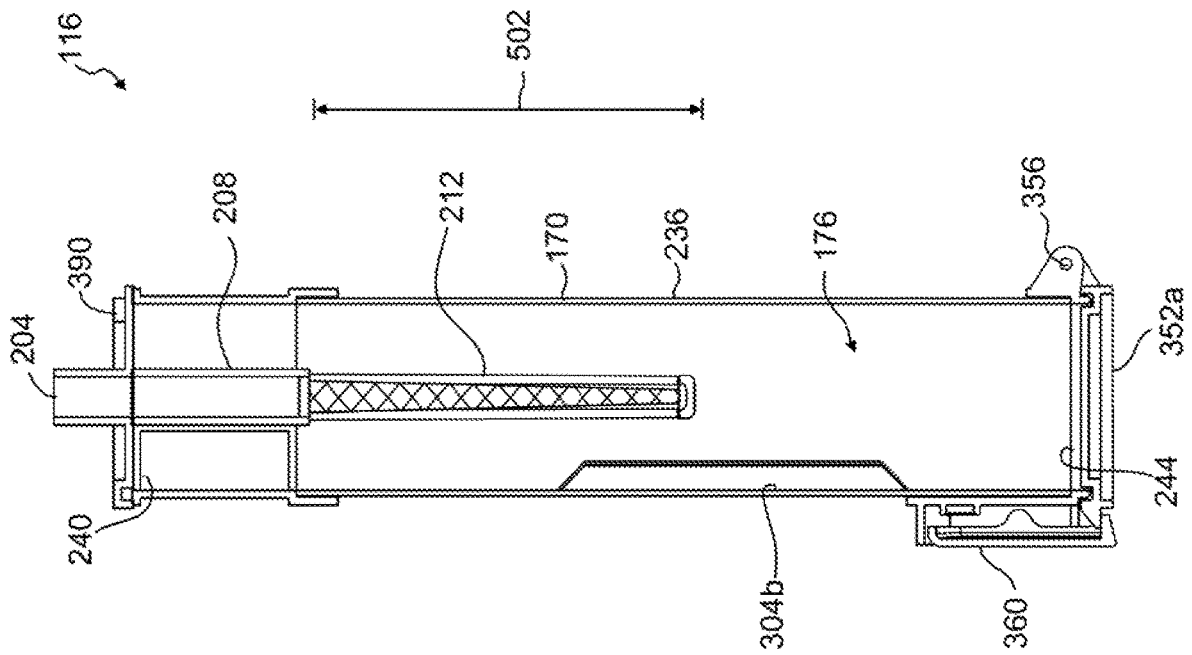

FIG. 50

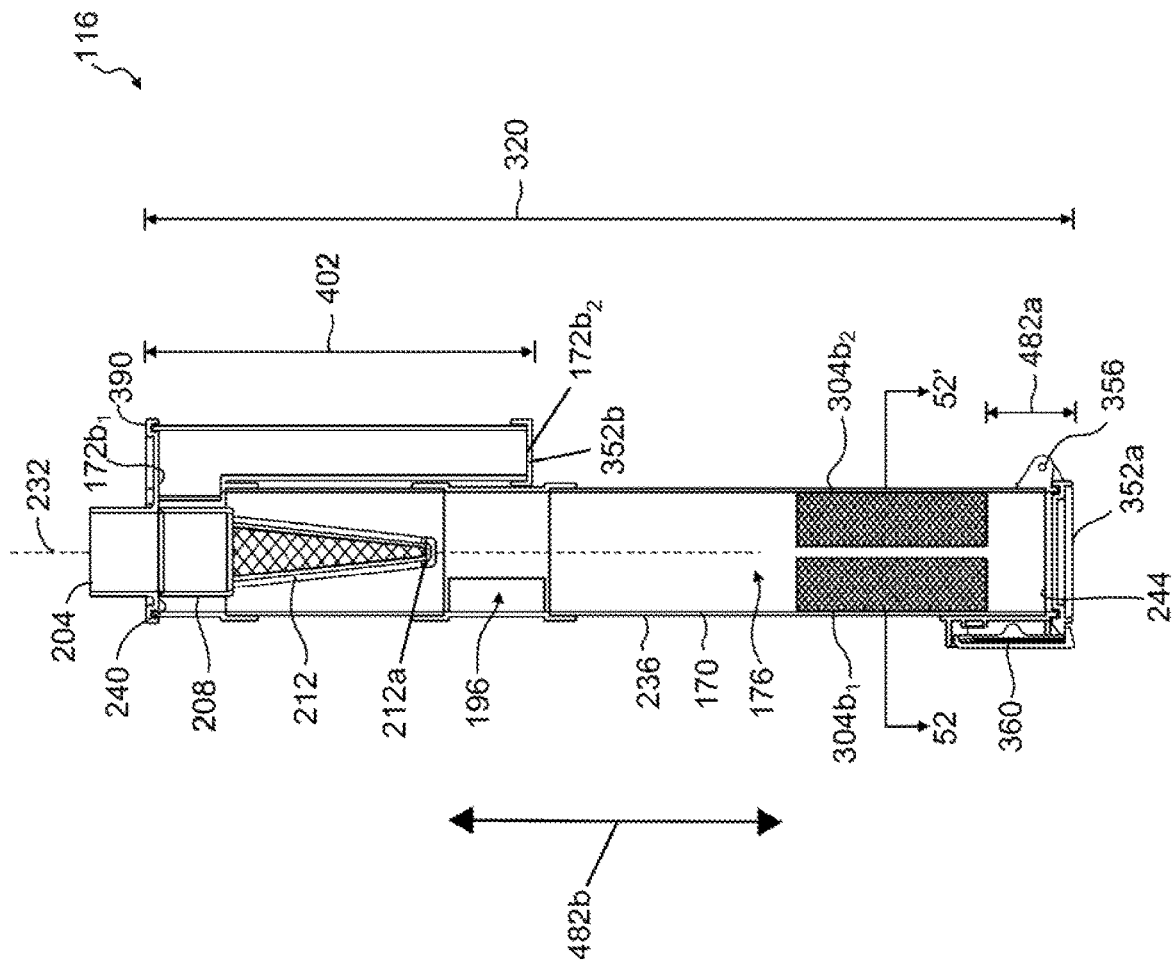

FIG. 51

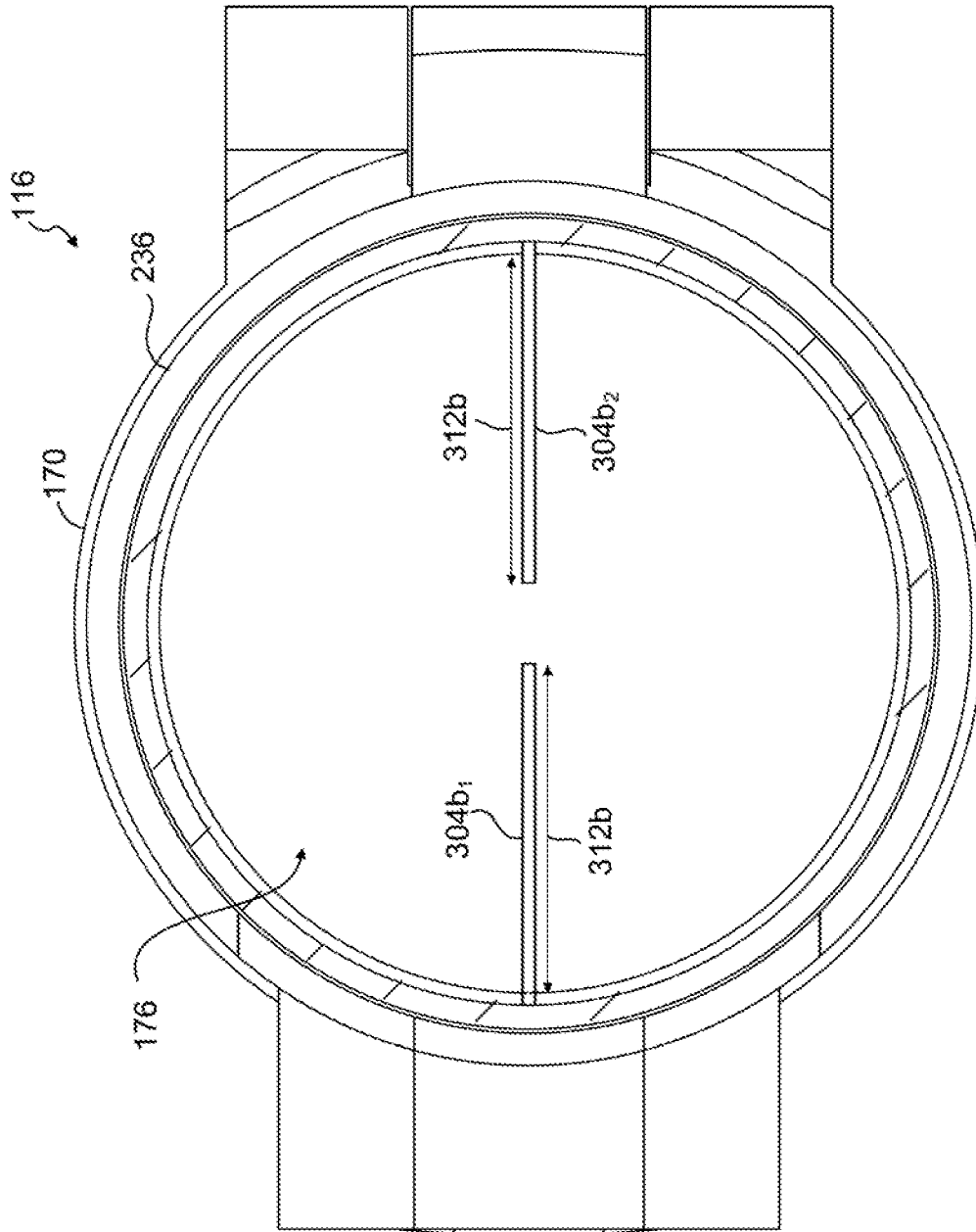

FIG. 52

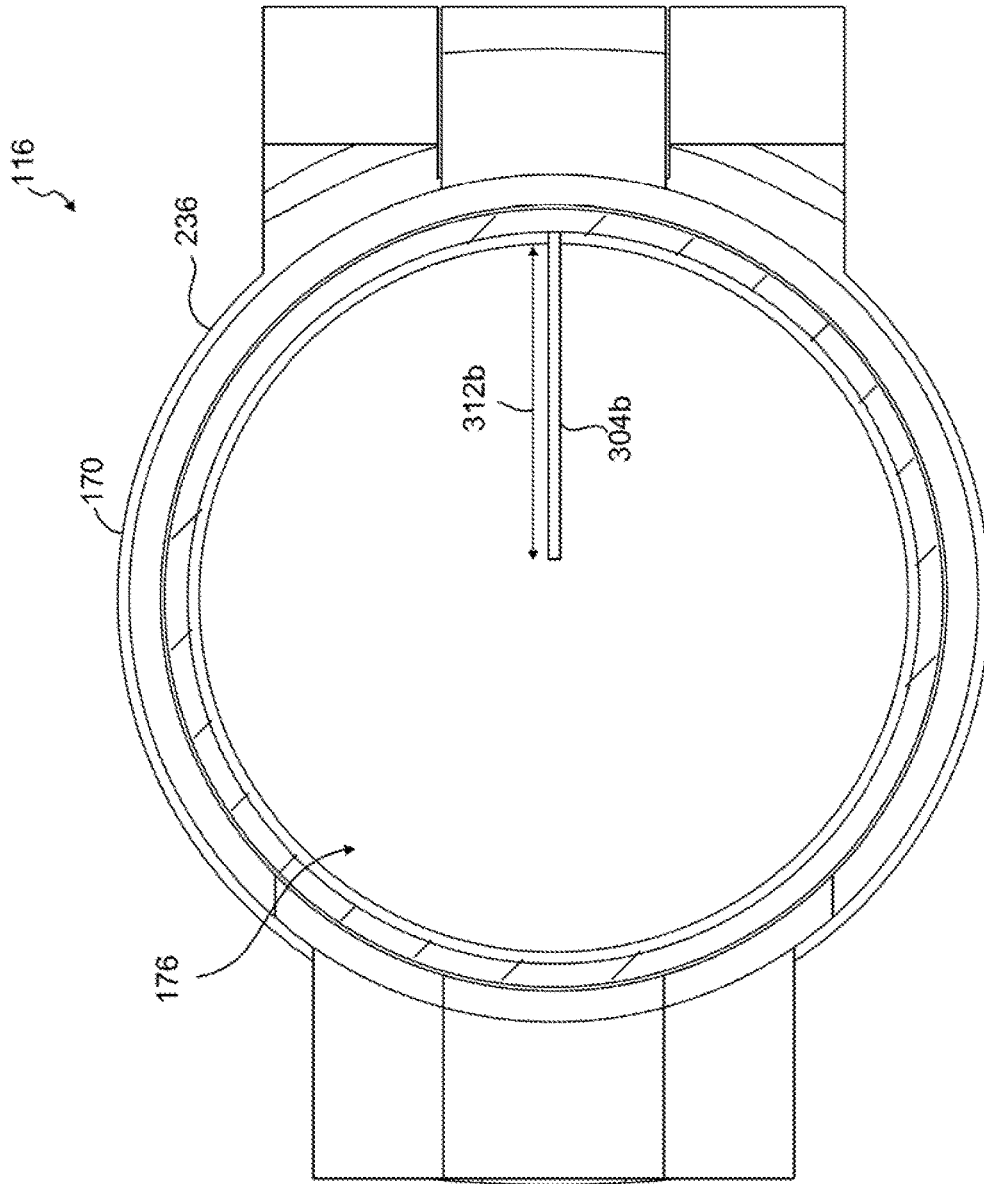

FIG. 53

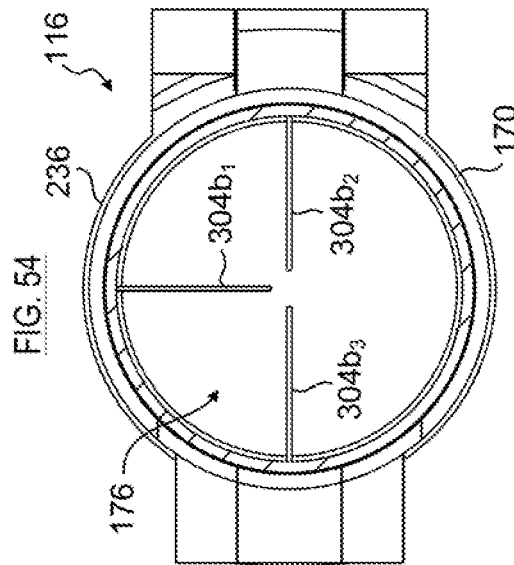
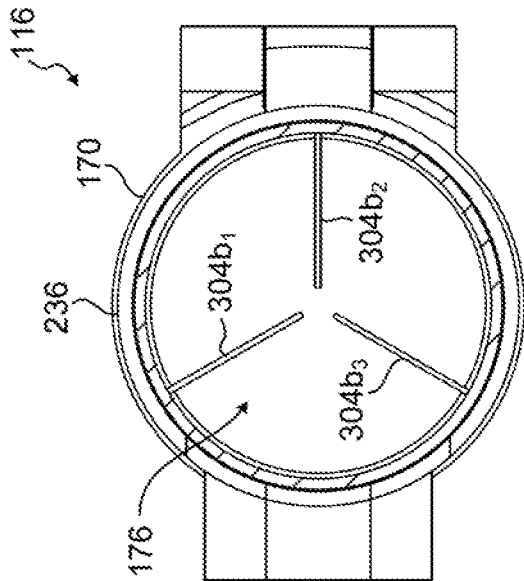
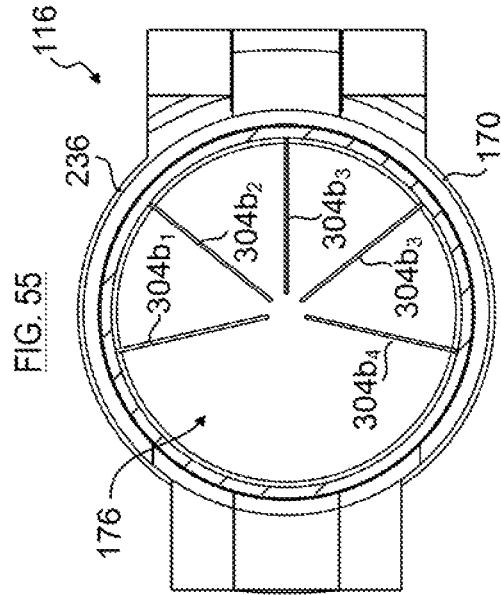
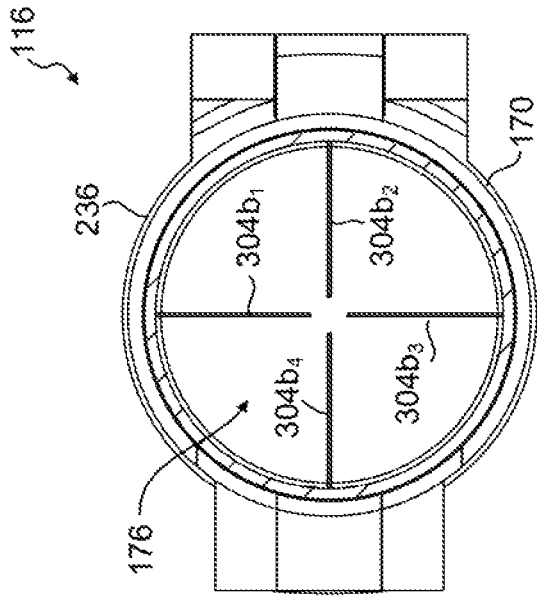

FIG. 55

FIG. 57

FIG. 54

FIG. 56

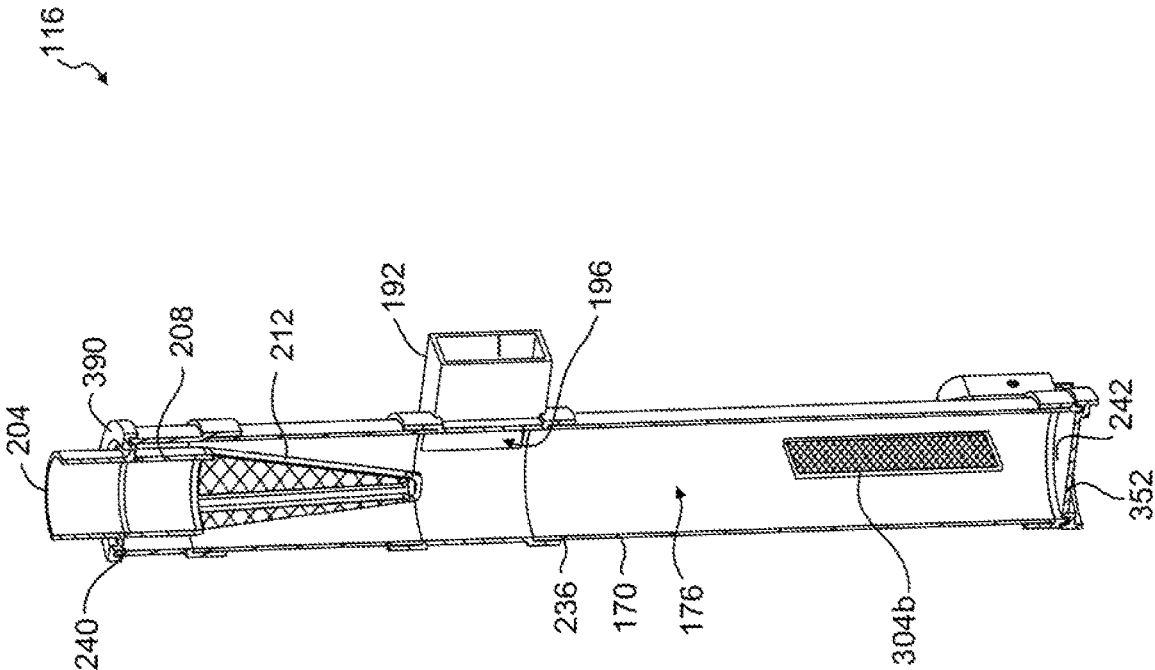

FIG. 58

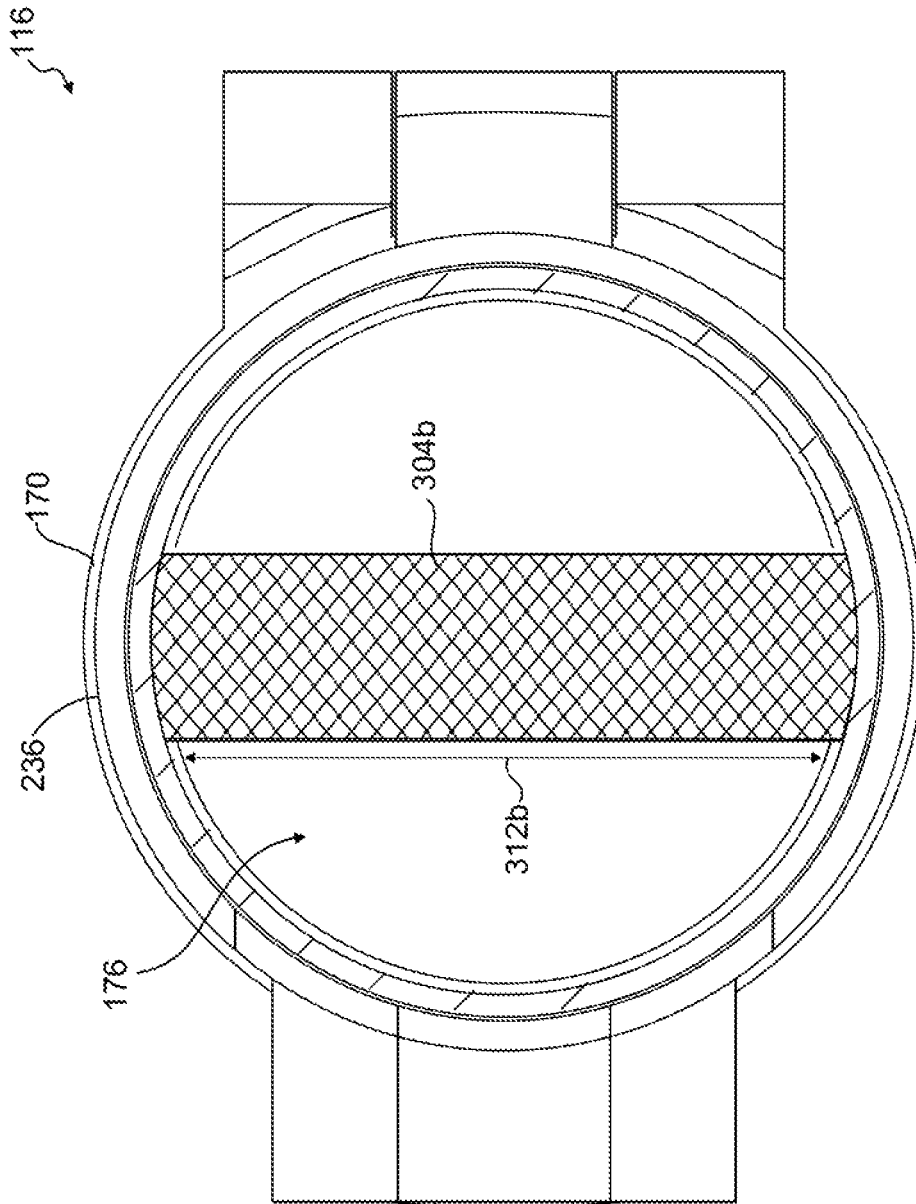

FIG. 59

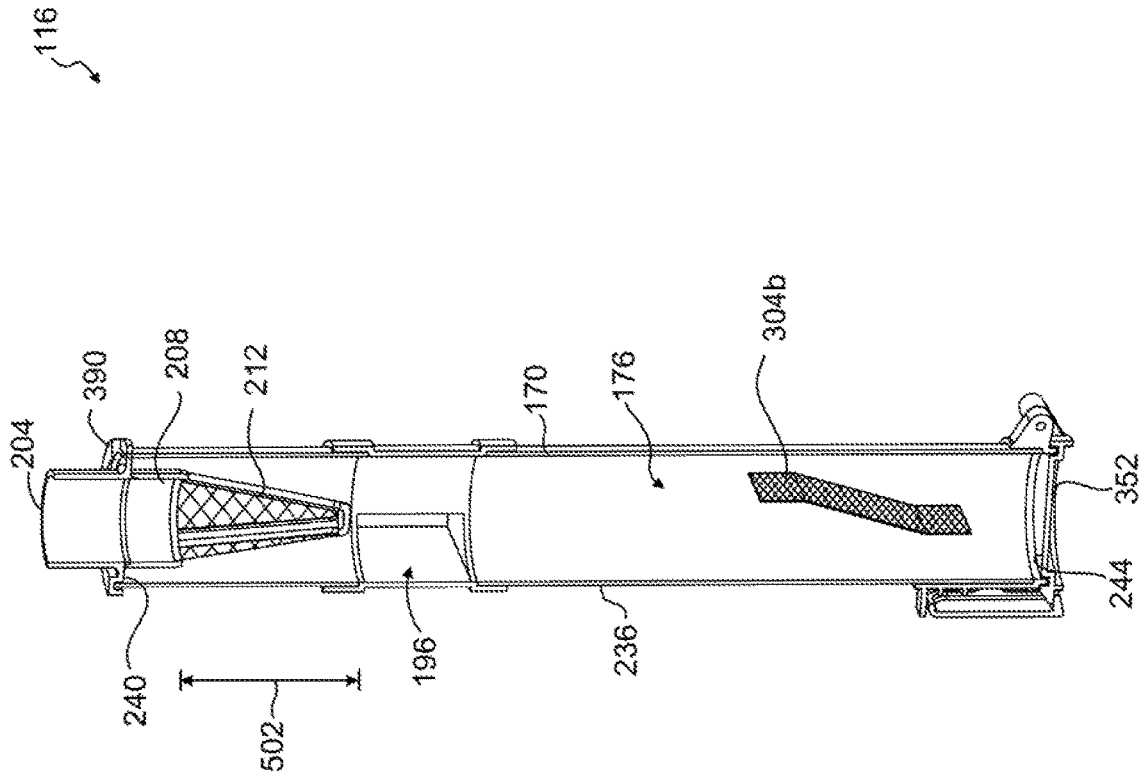

FIG. 60

116

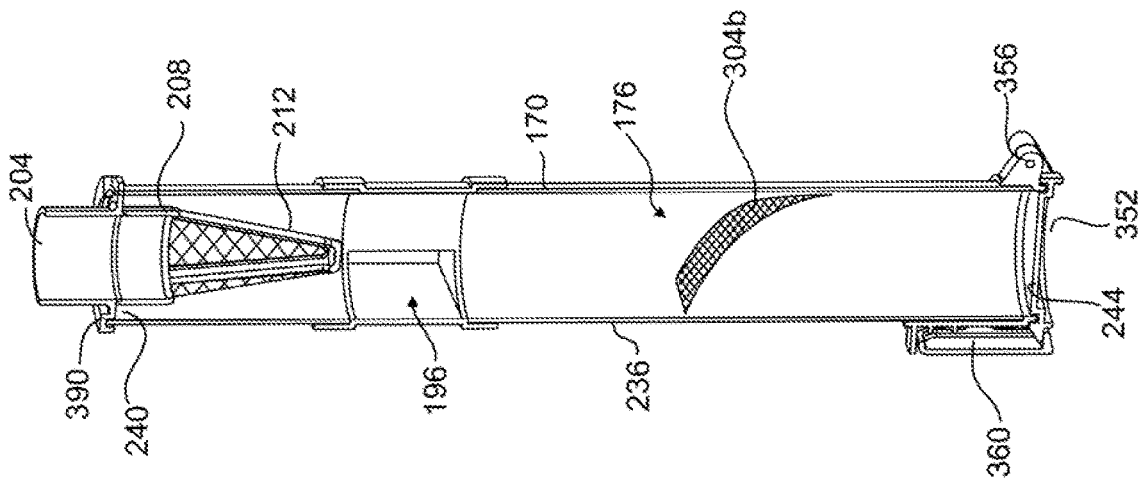

FIG. 61

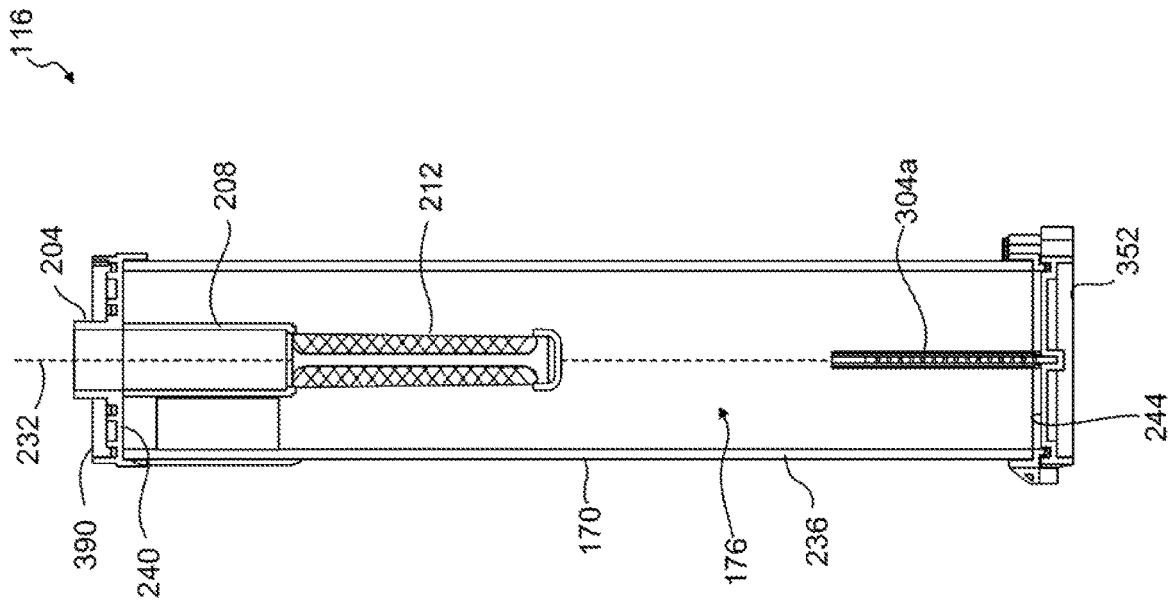

FIG. 62

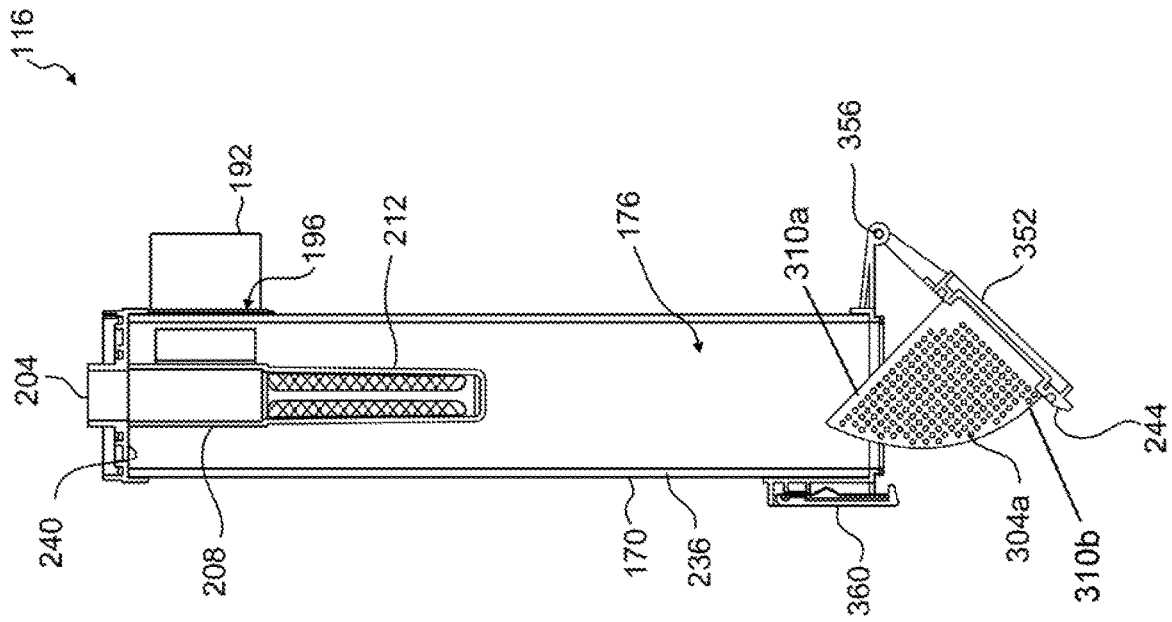

FIG. 63

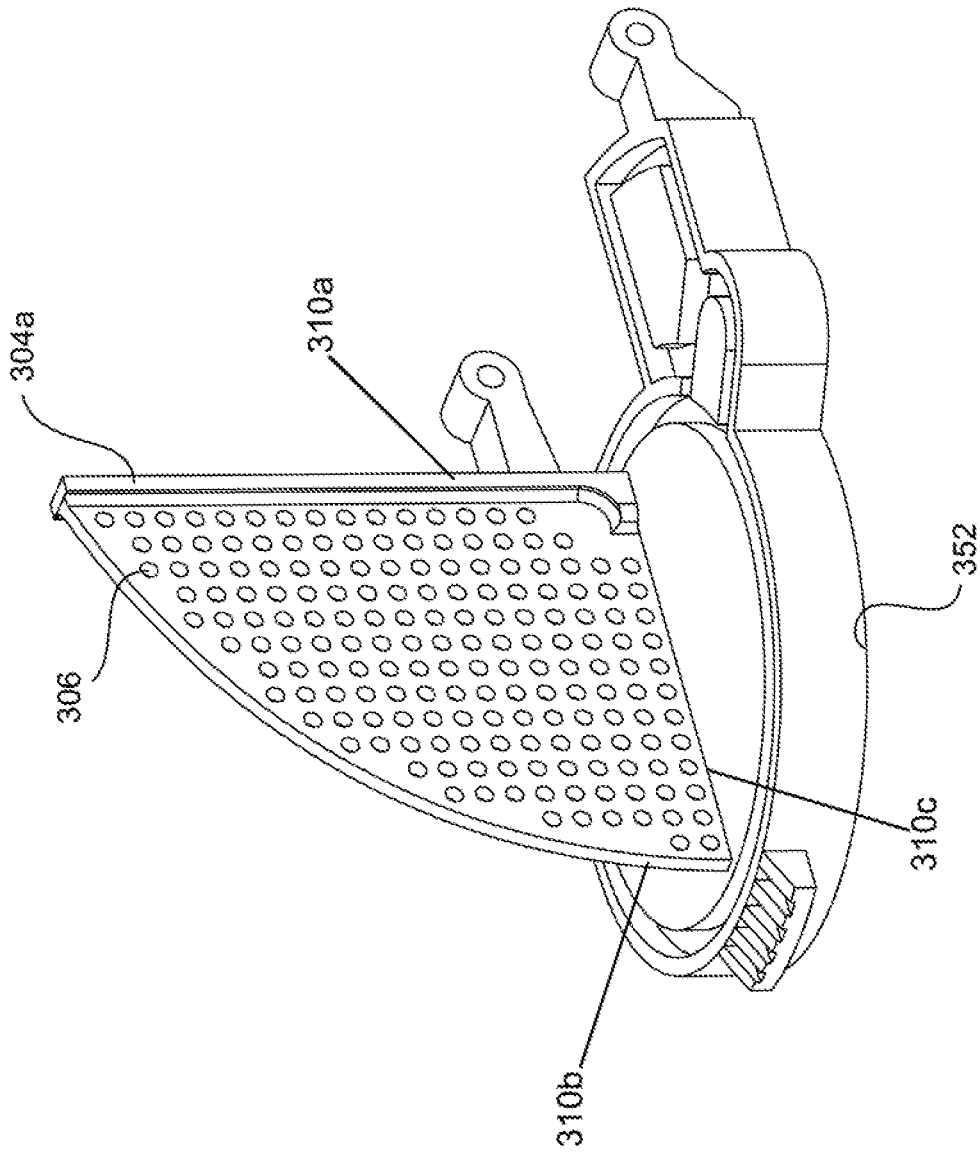

FIG. 64

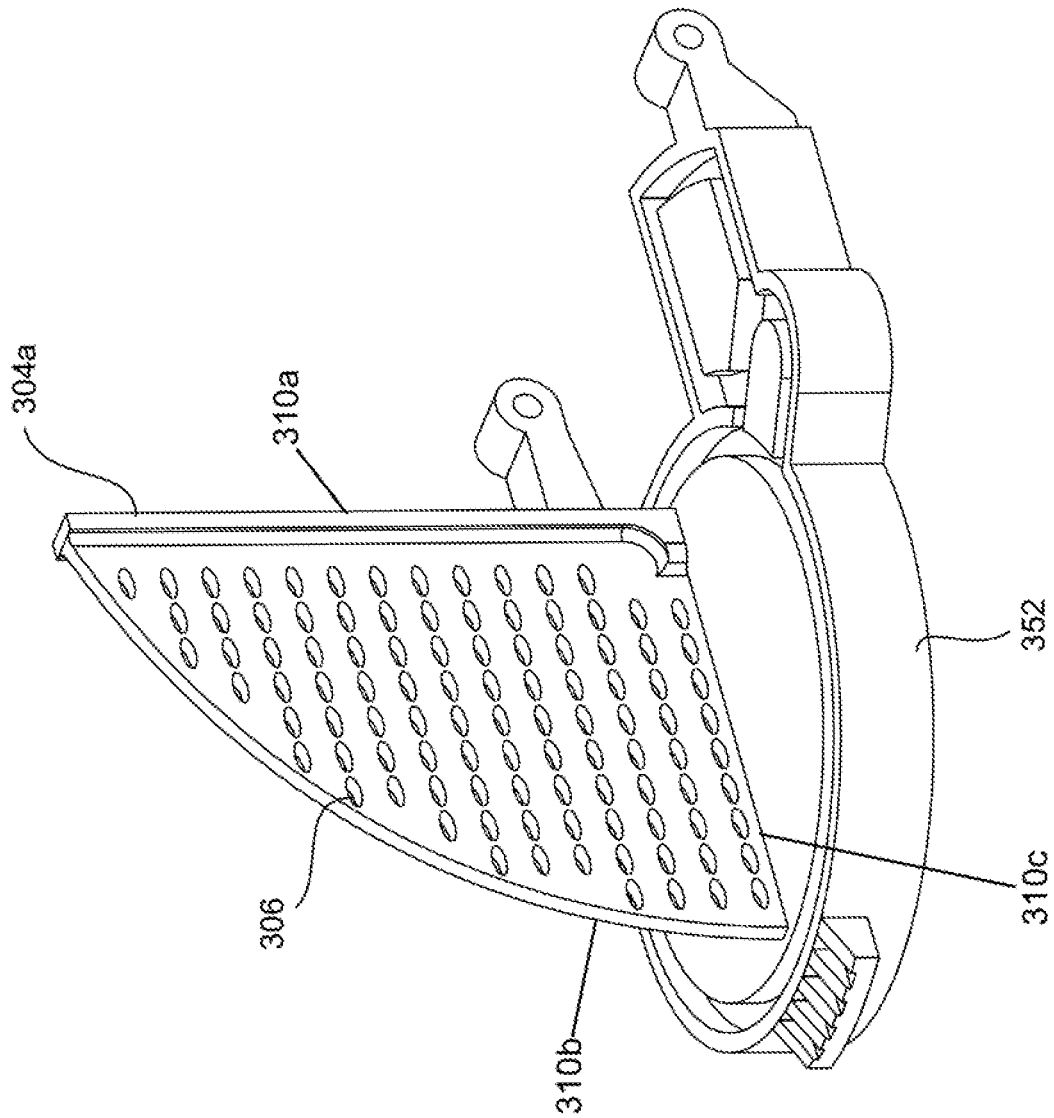

FIG. 65

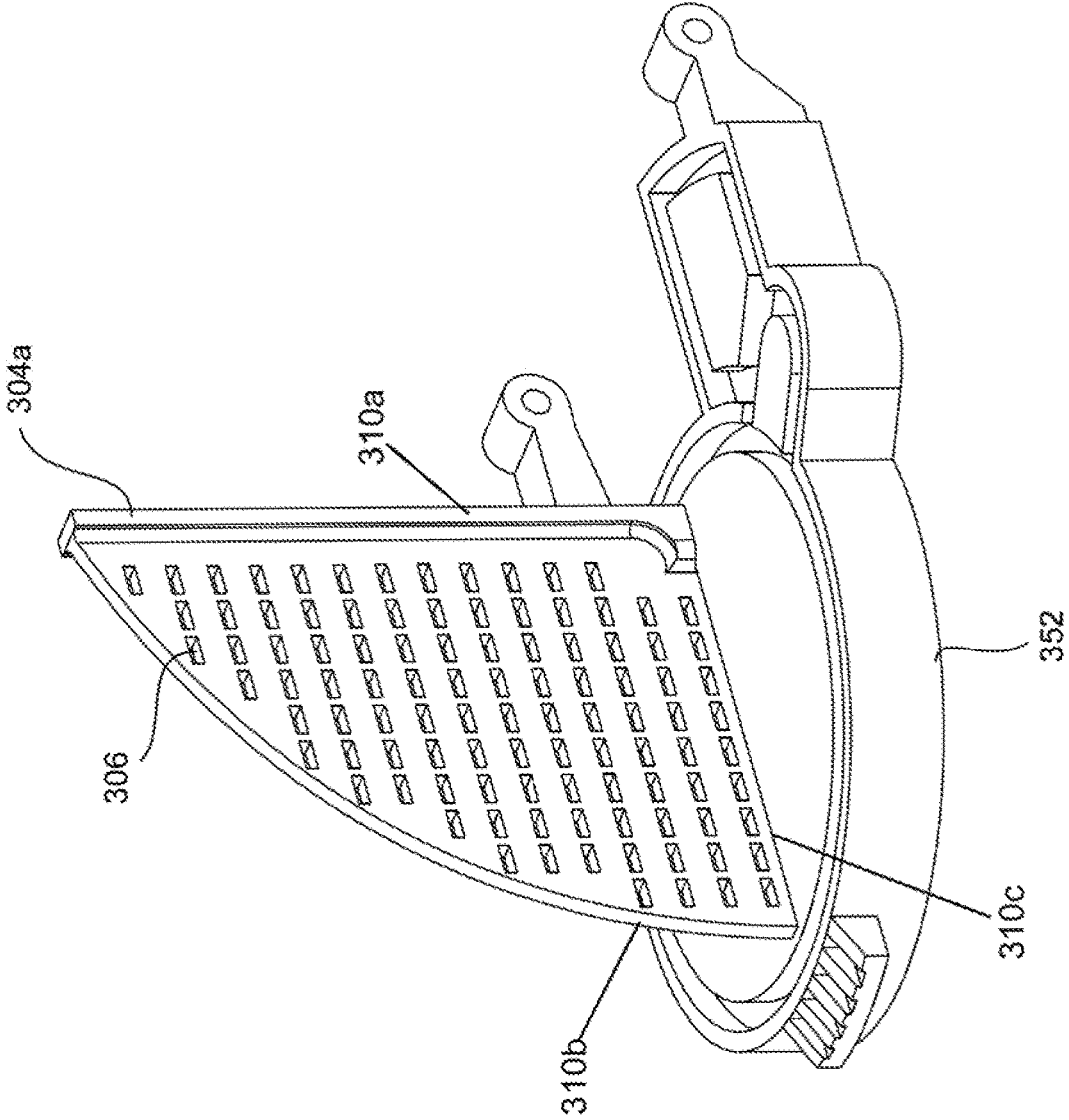

FIG. 66

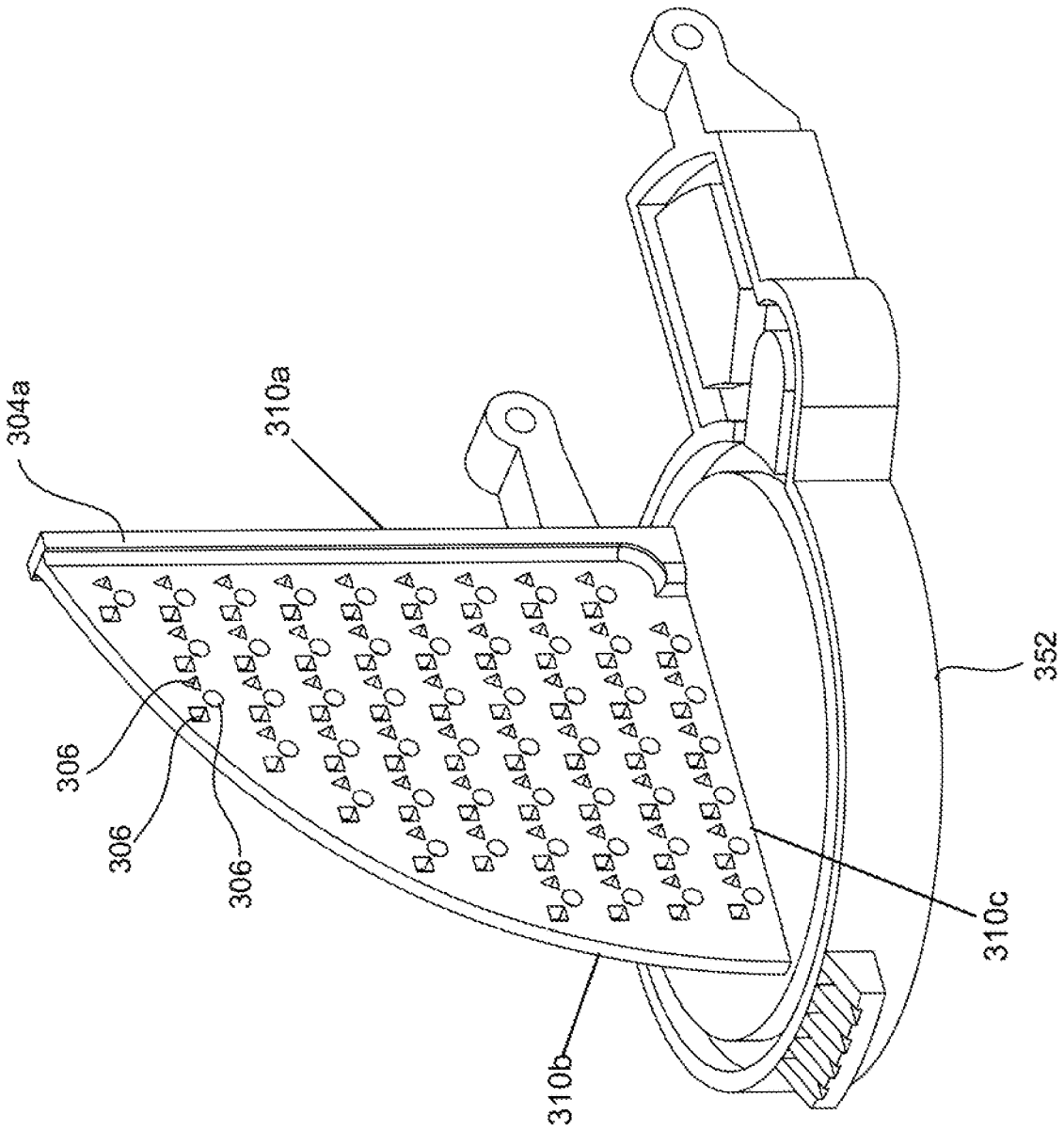

FIG. 67

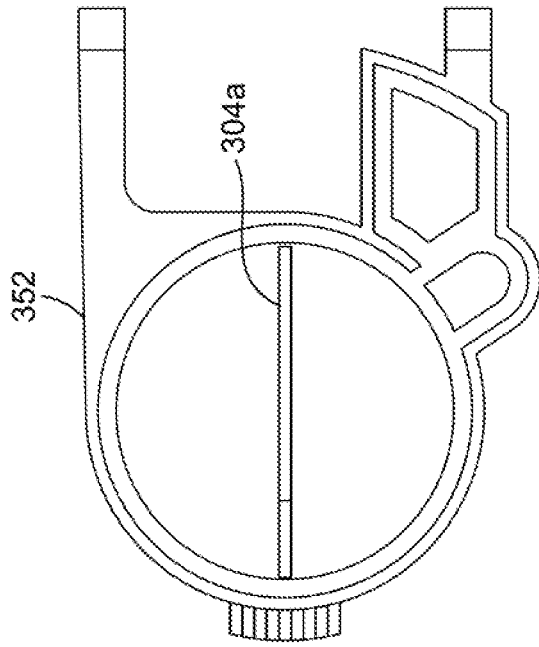

FIG. 68B

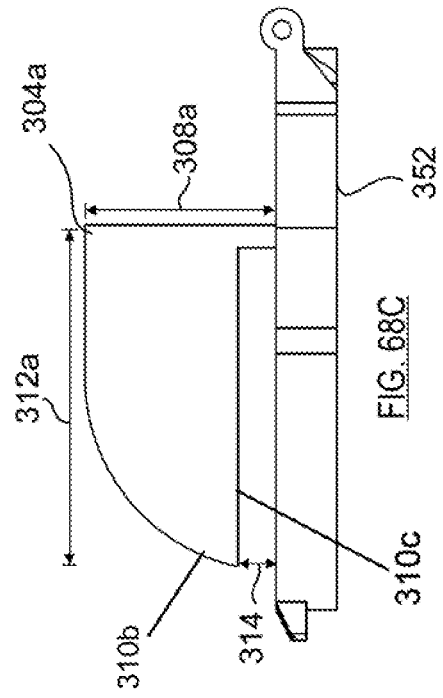

FIG. 68C

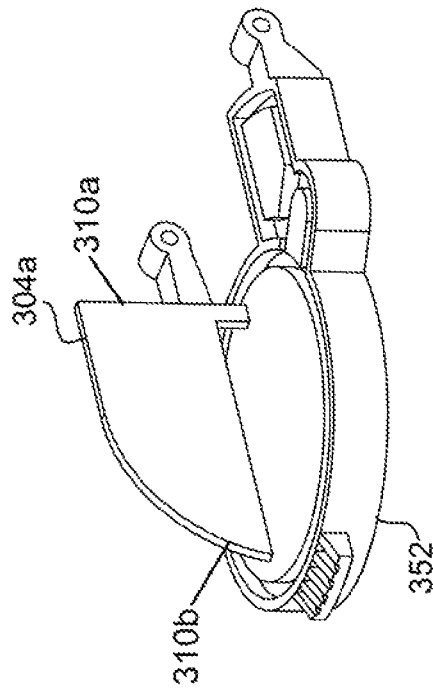

FIG. 68A

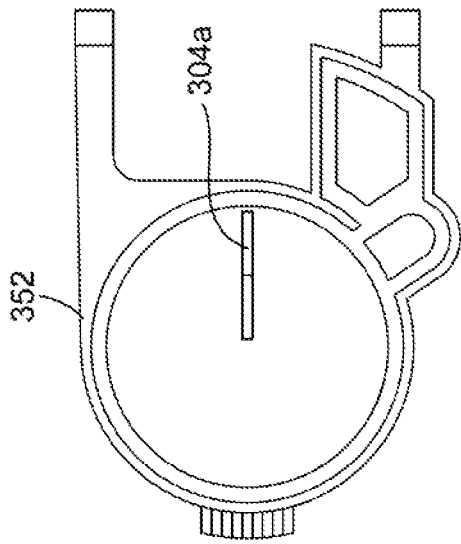

FIG. 69B

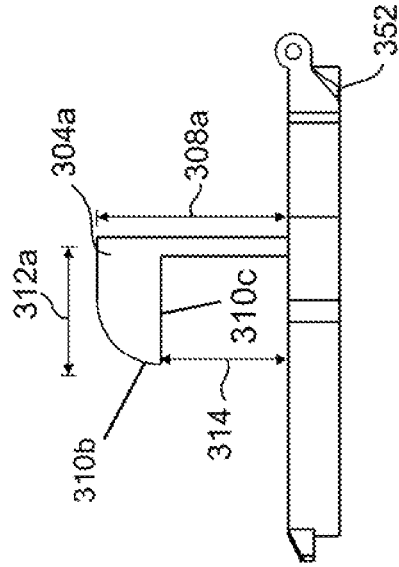

FIG. 69C

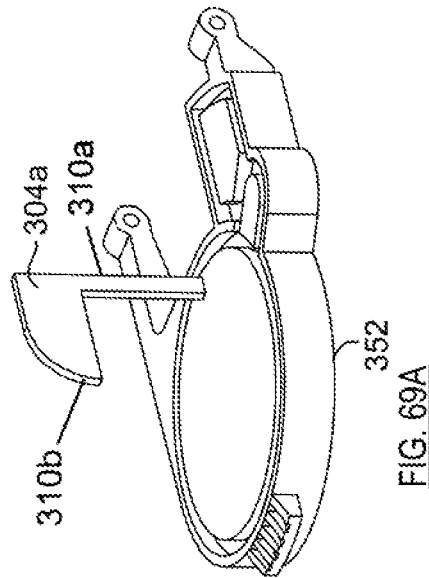

FIG. 69A

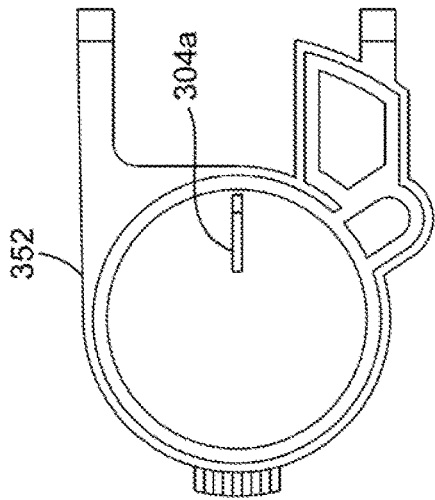

FIG. 70B

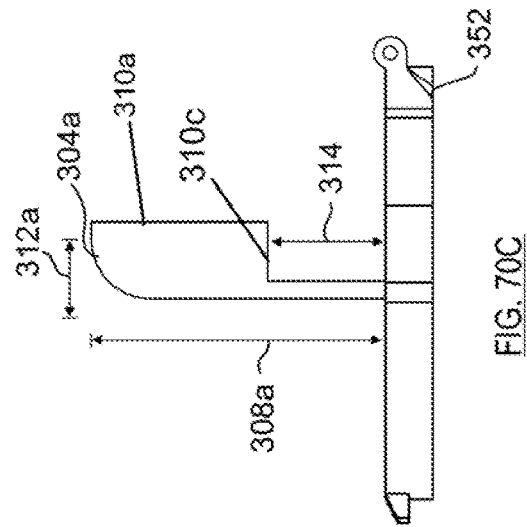

FIG. 70C

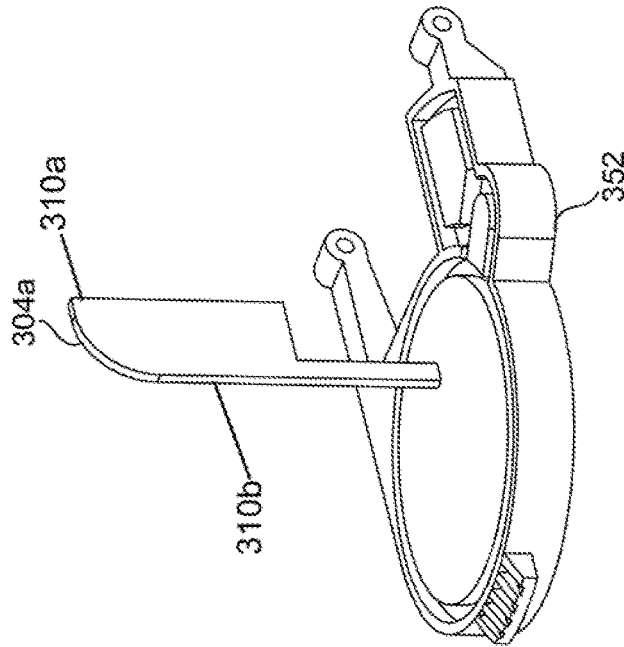

FIG. 70A

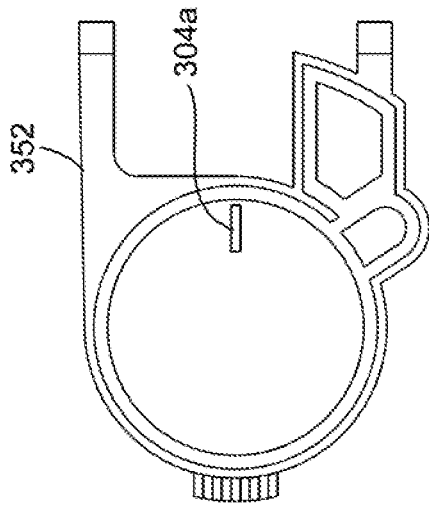

FIG. 71B

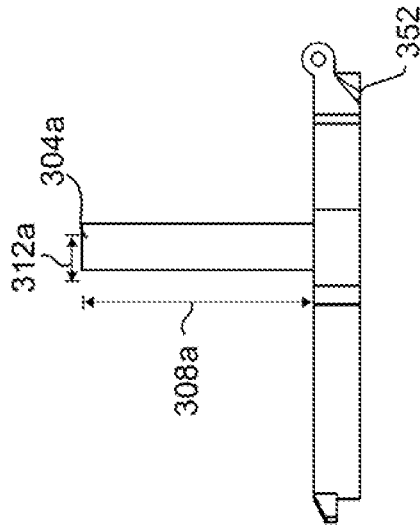

FIG. 71C

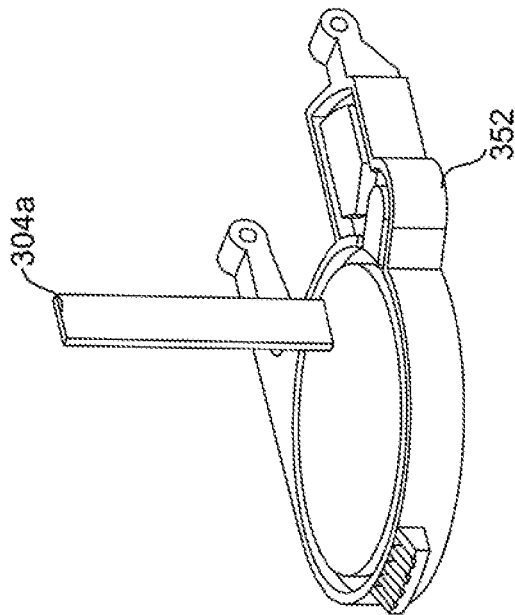

FIG. 71A

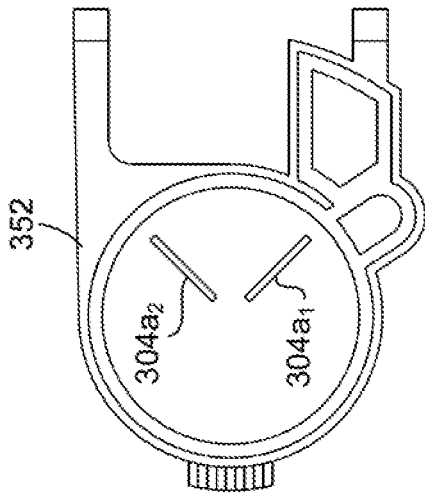

FIG. 72B

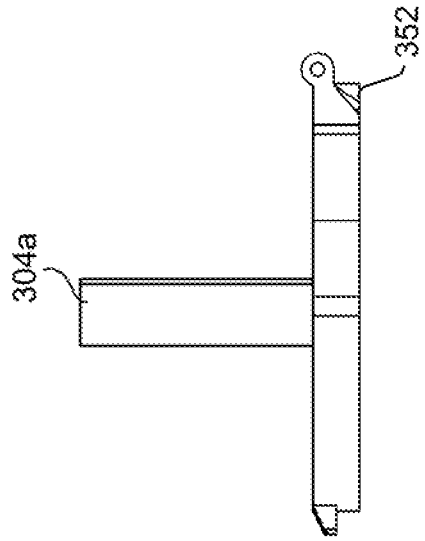

FIG. 72C

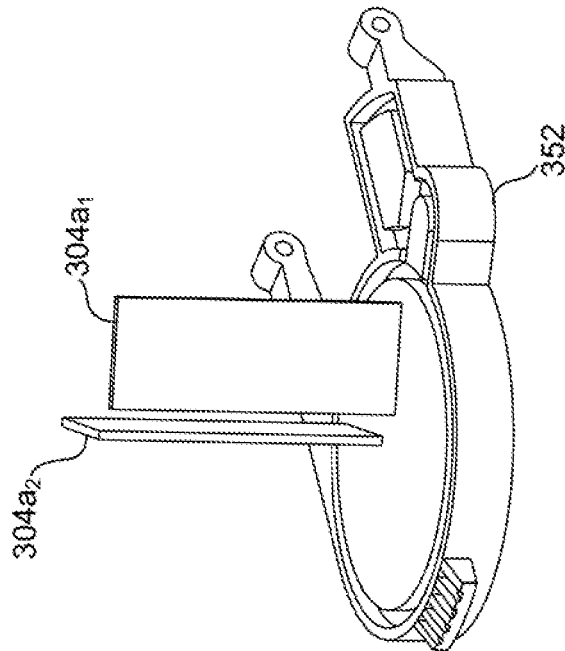

FIG. 72A

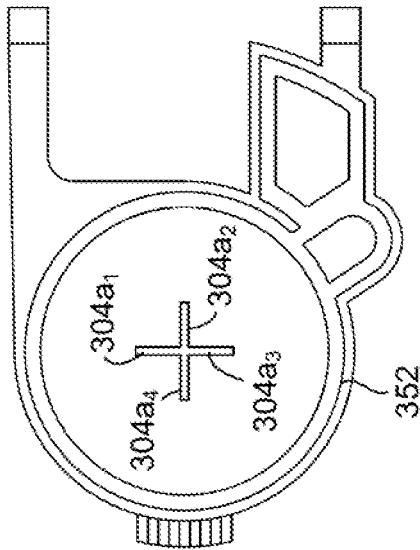

FIG. 73B

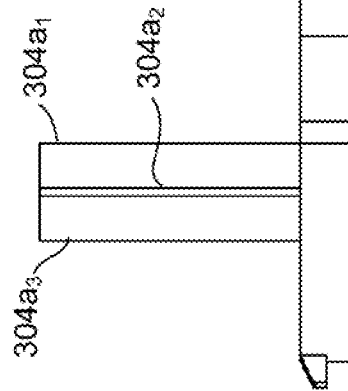

FIG. 73C

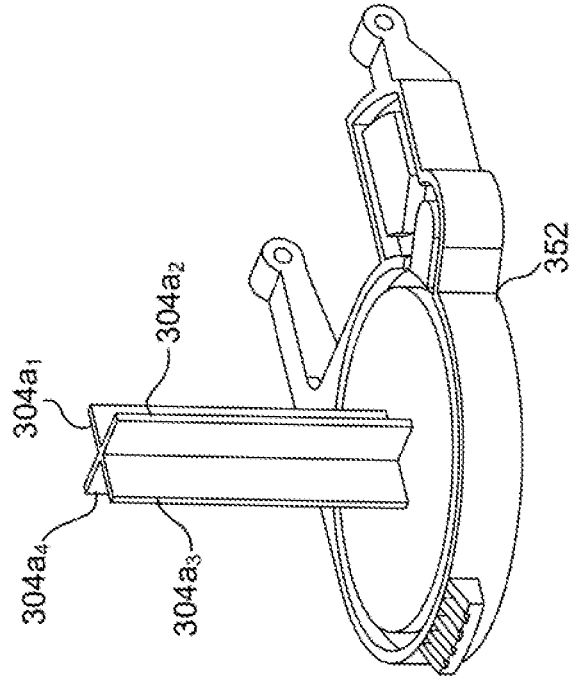

FIG. 73A

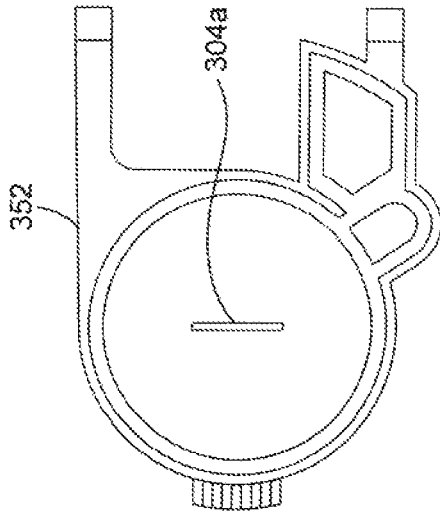

FIG. 74B

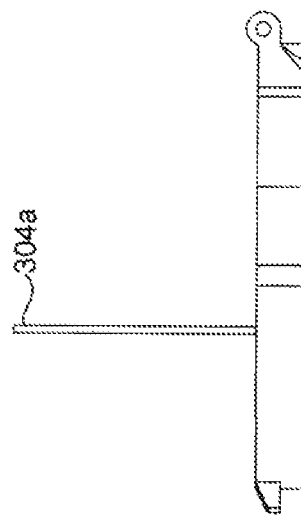

FIG. 74C

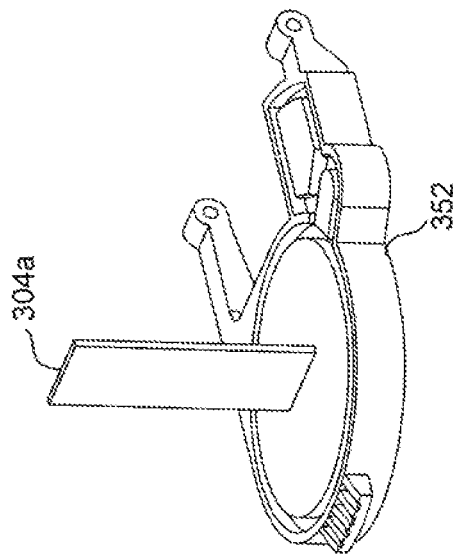

FIG. 74A

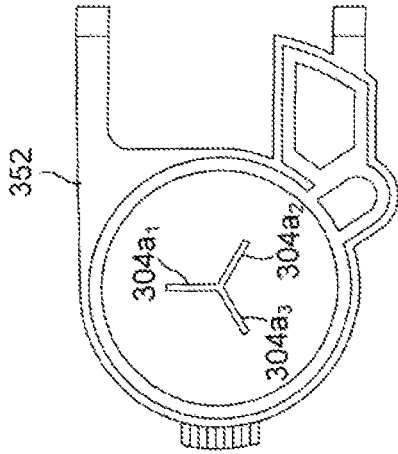

FIG. 75B

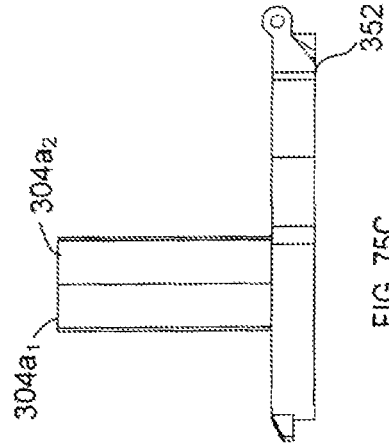

FIG. 75C

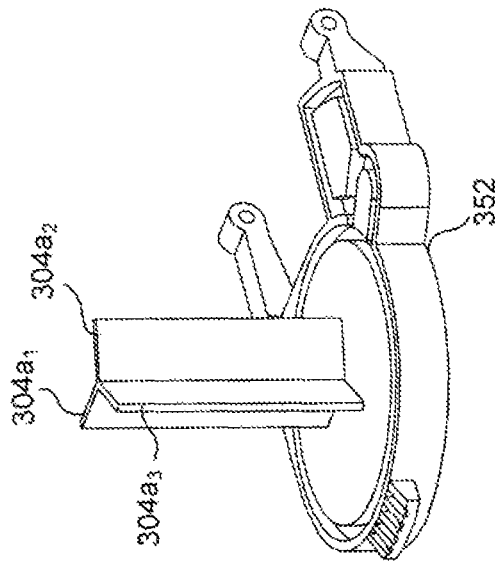

FIG. 75A

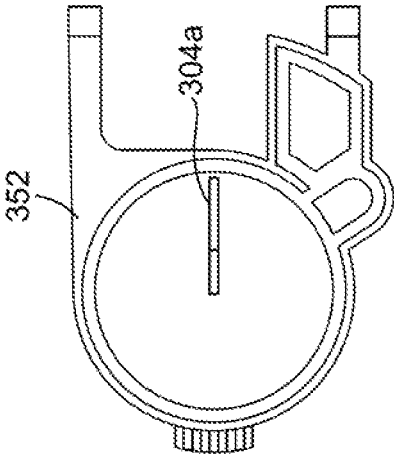

FIG. 76B

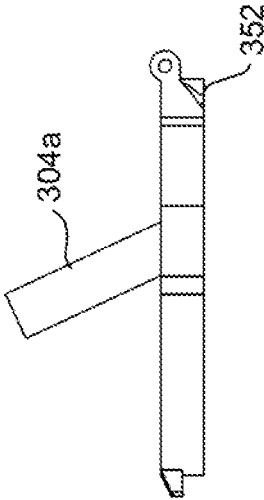

FIG. 76C

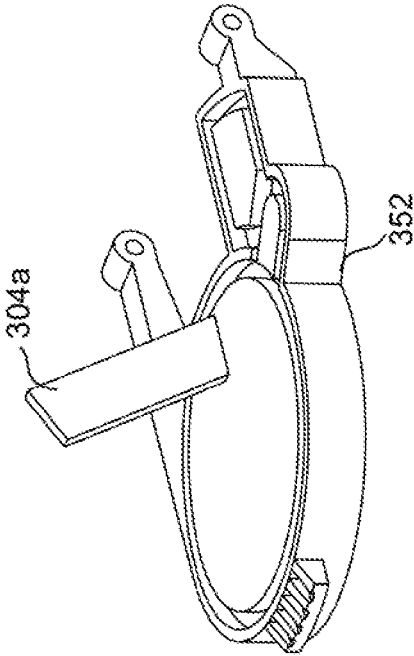

FIG. 76A

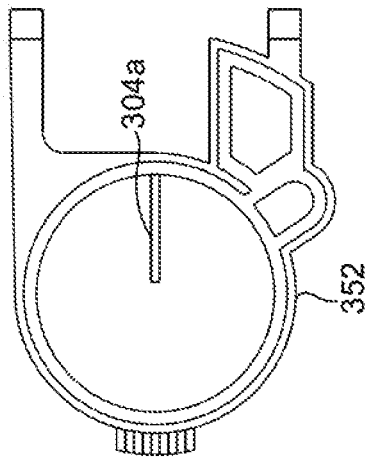

FIG. 77B

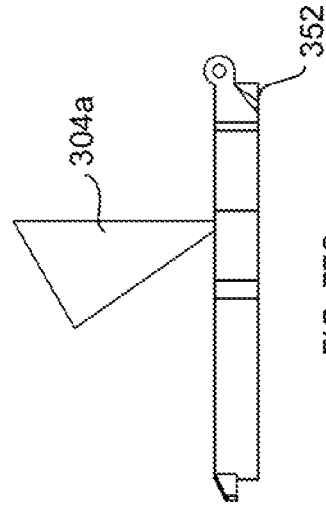

FIG. 77C

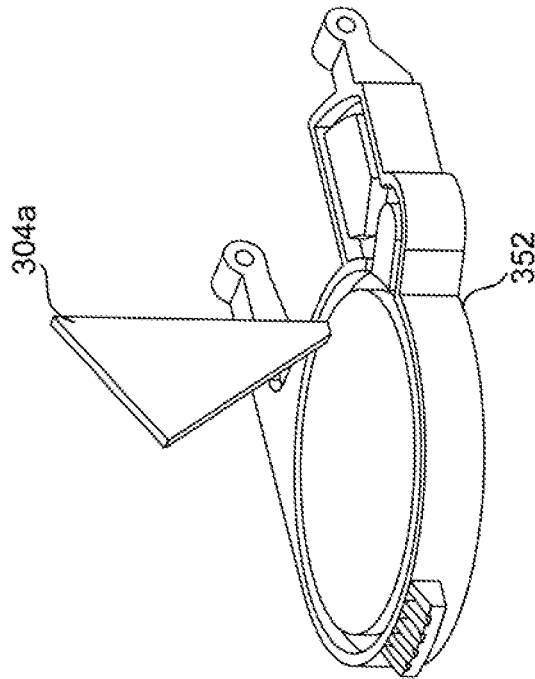

FIG. 77A

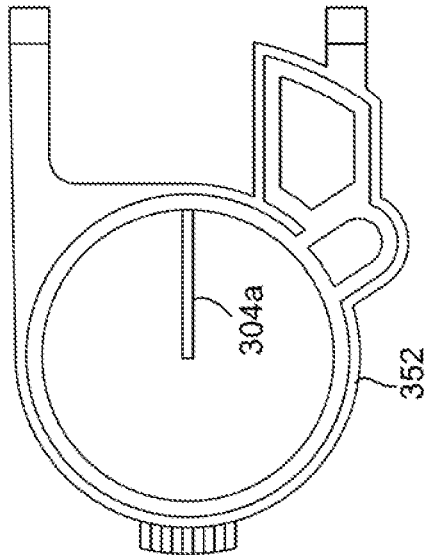

FIG. 78B

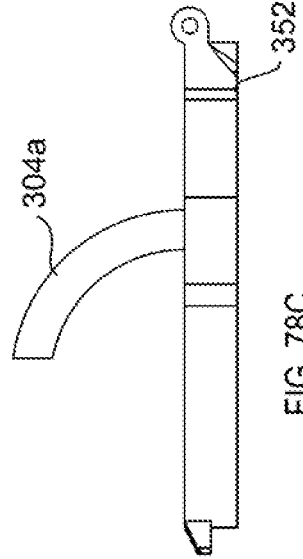

FIG. 78C

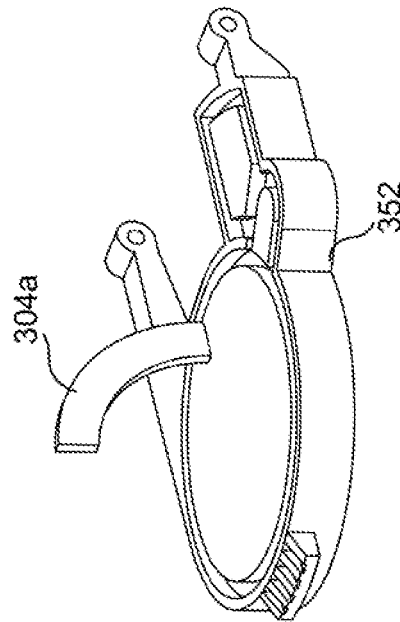

FIG. 78A

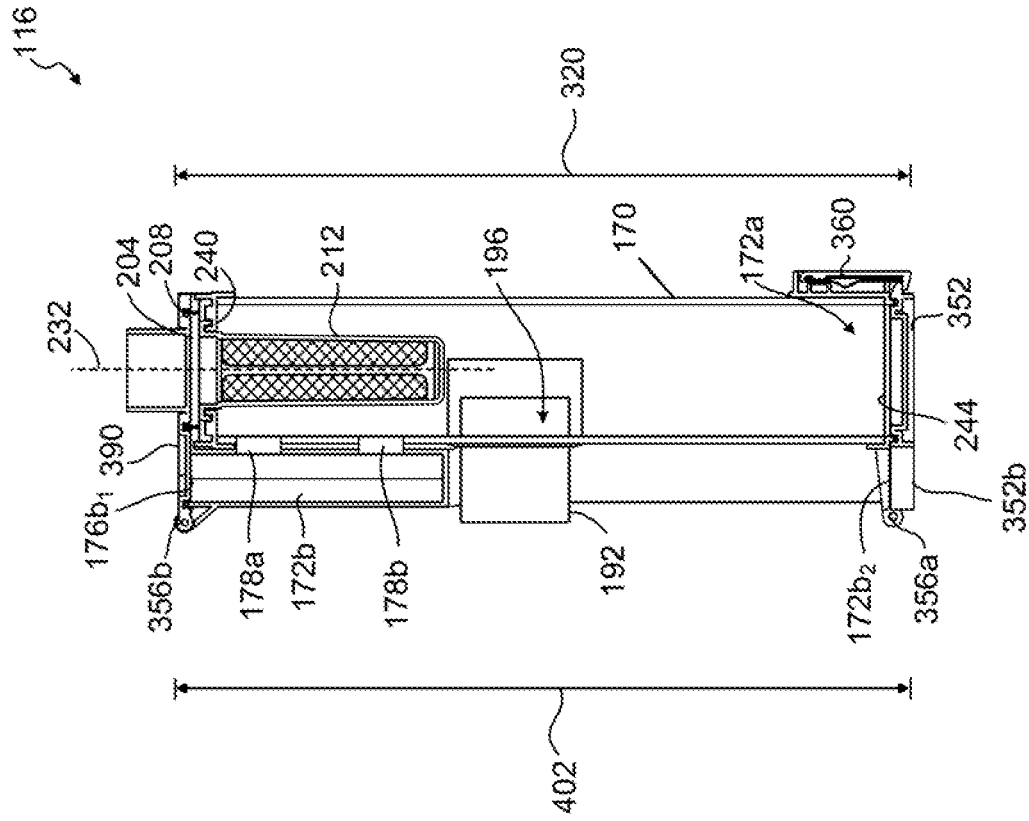

FIG. 79

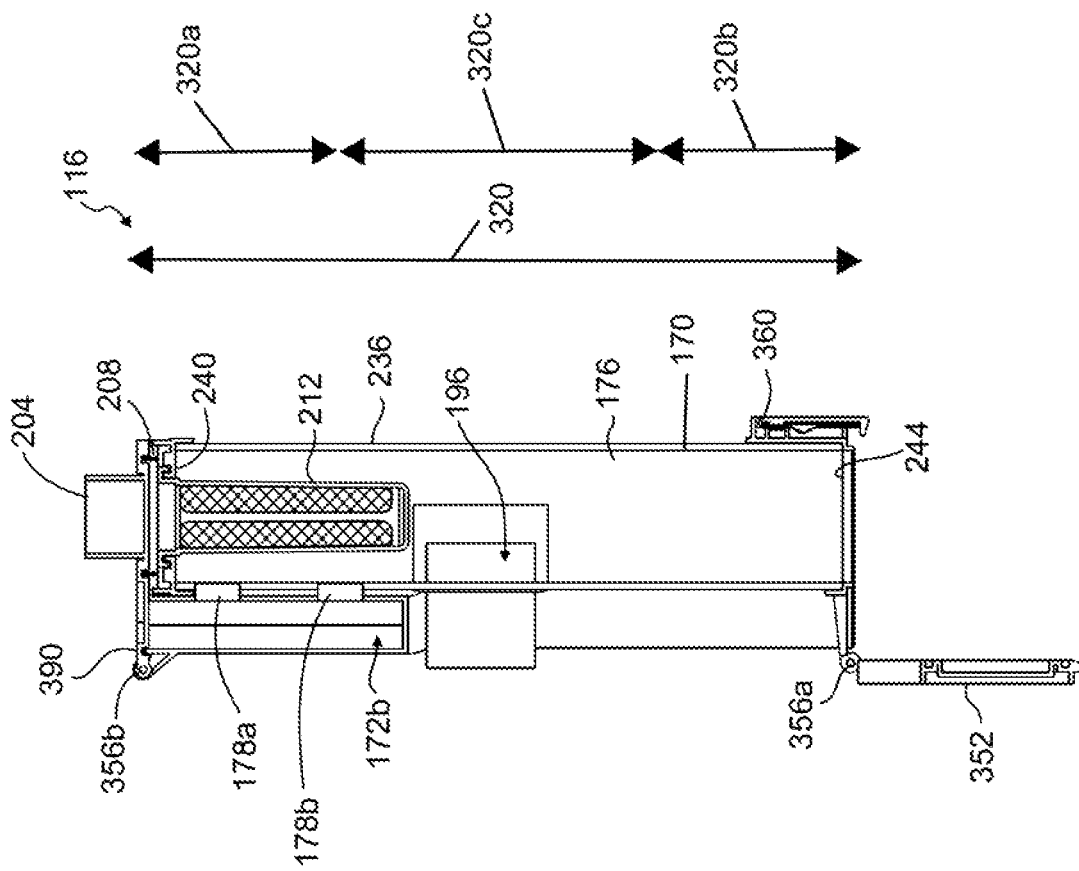

FIG. 80

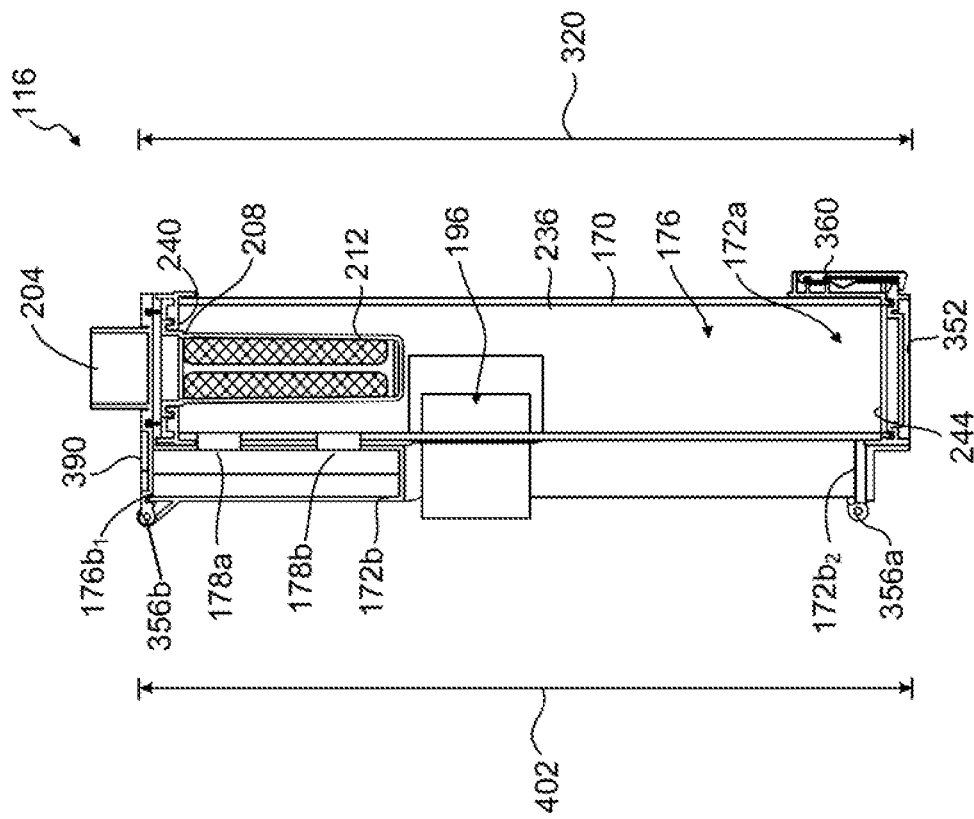

FIG. 81

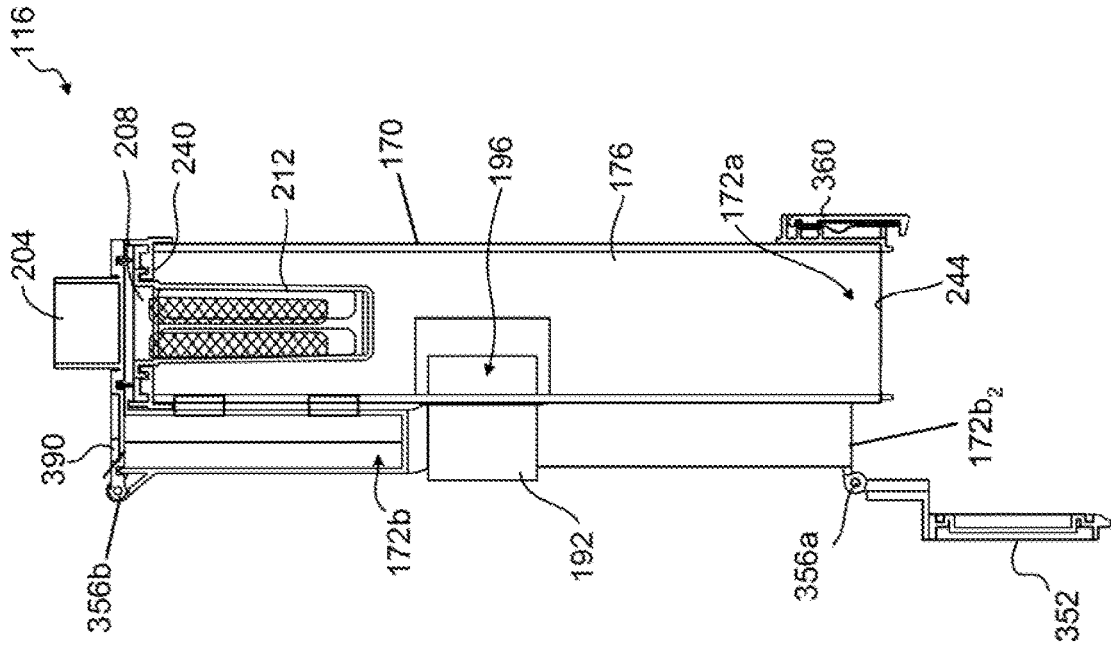

FIG. 82

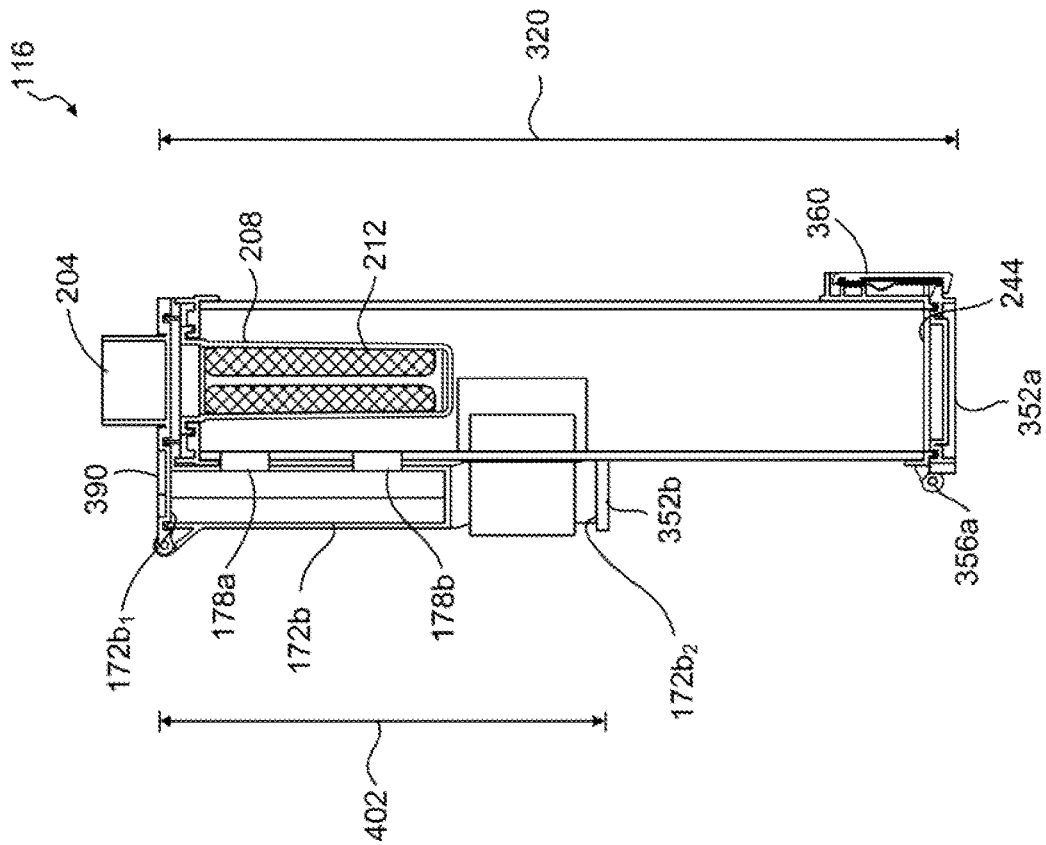

FIG. 83

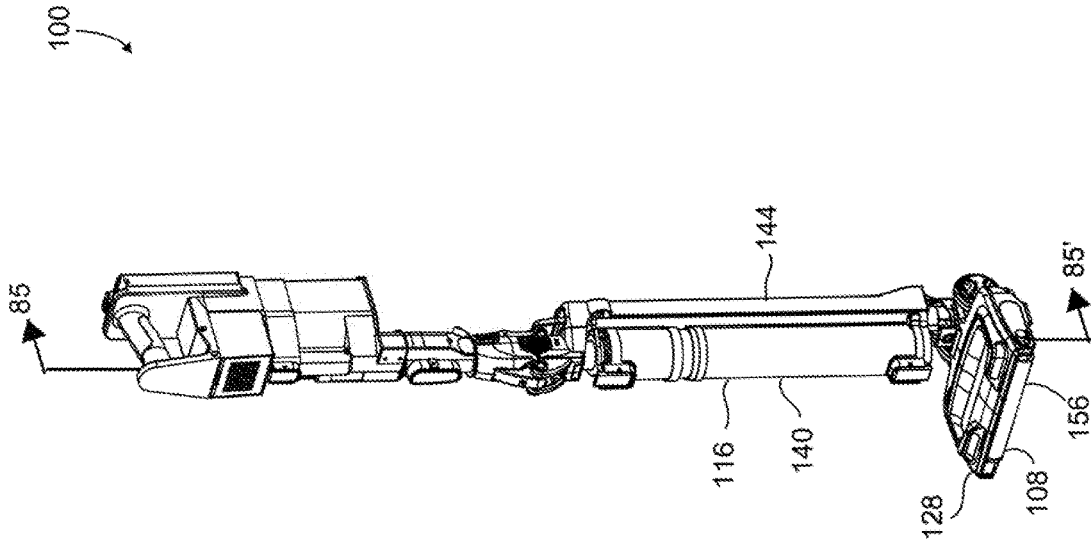

FIG. 84

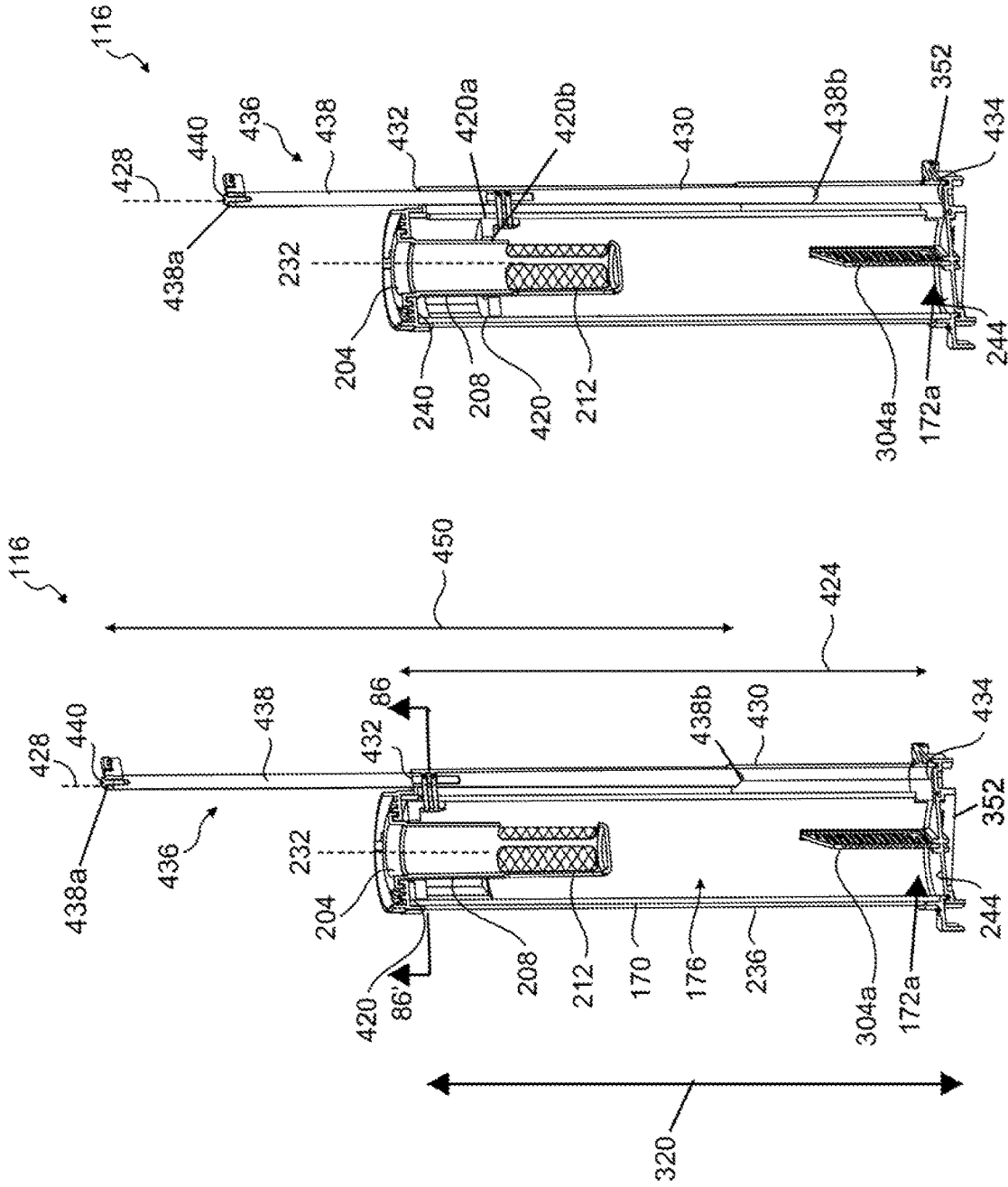

FIG. 85B

FIG. 85A

116

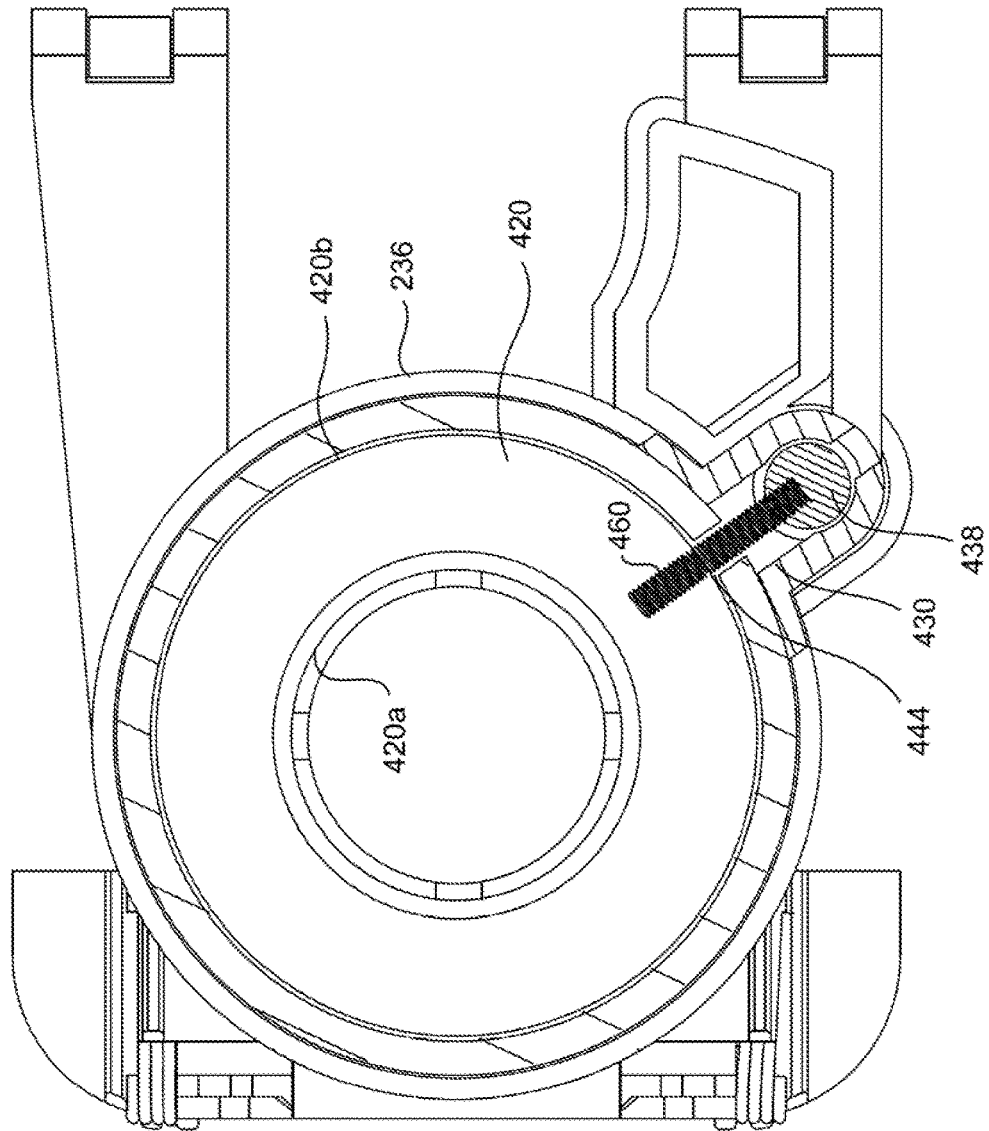

FIG. 86

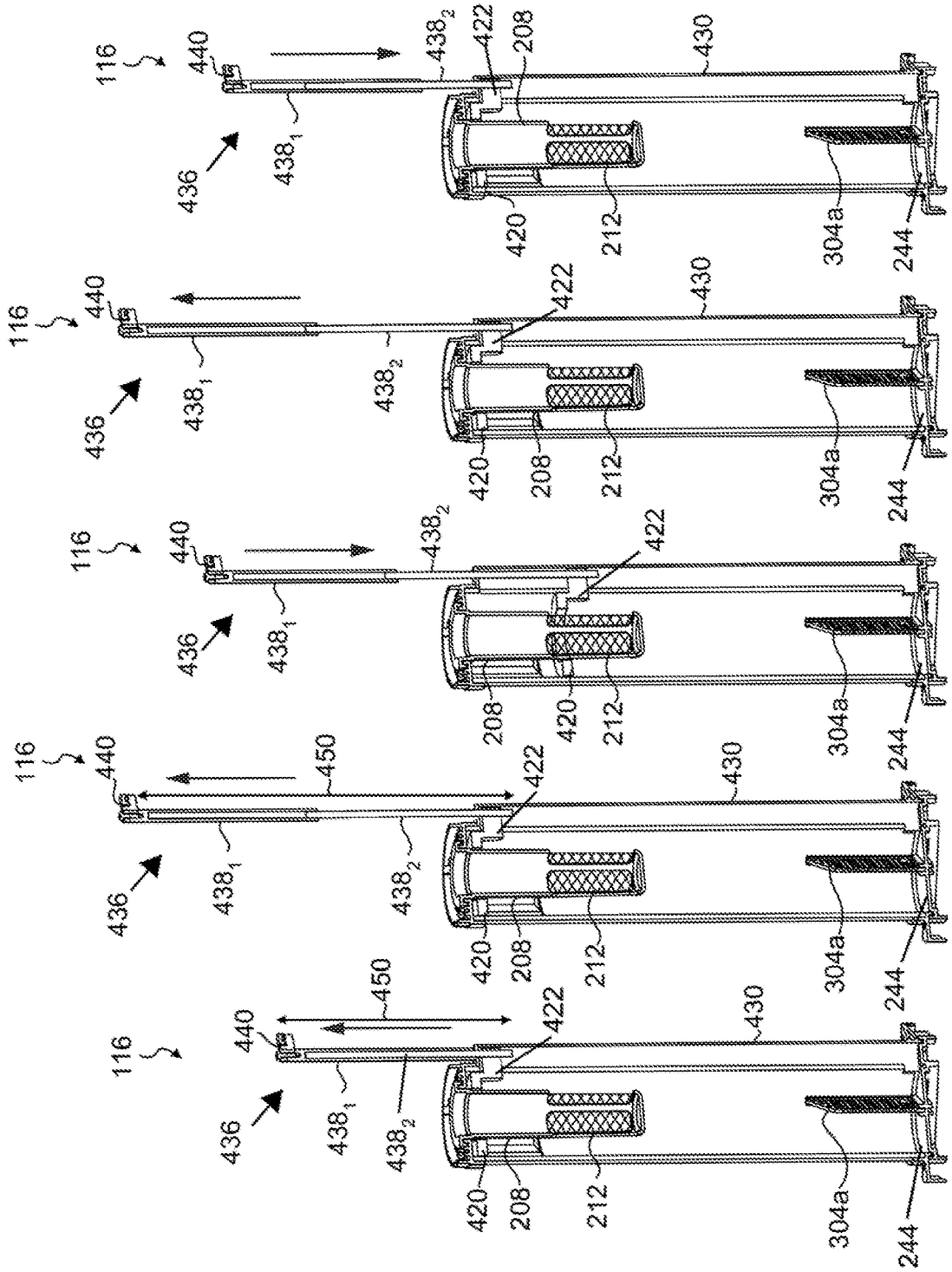

FIG. 87E

FIG. 87D

FIG. 87C

FIG. 87B

FIG. 87A

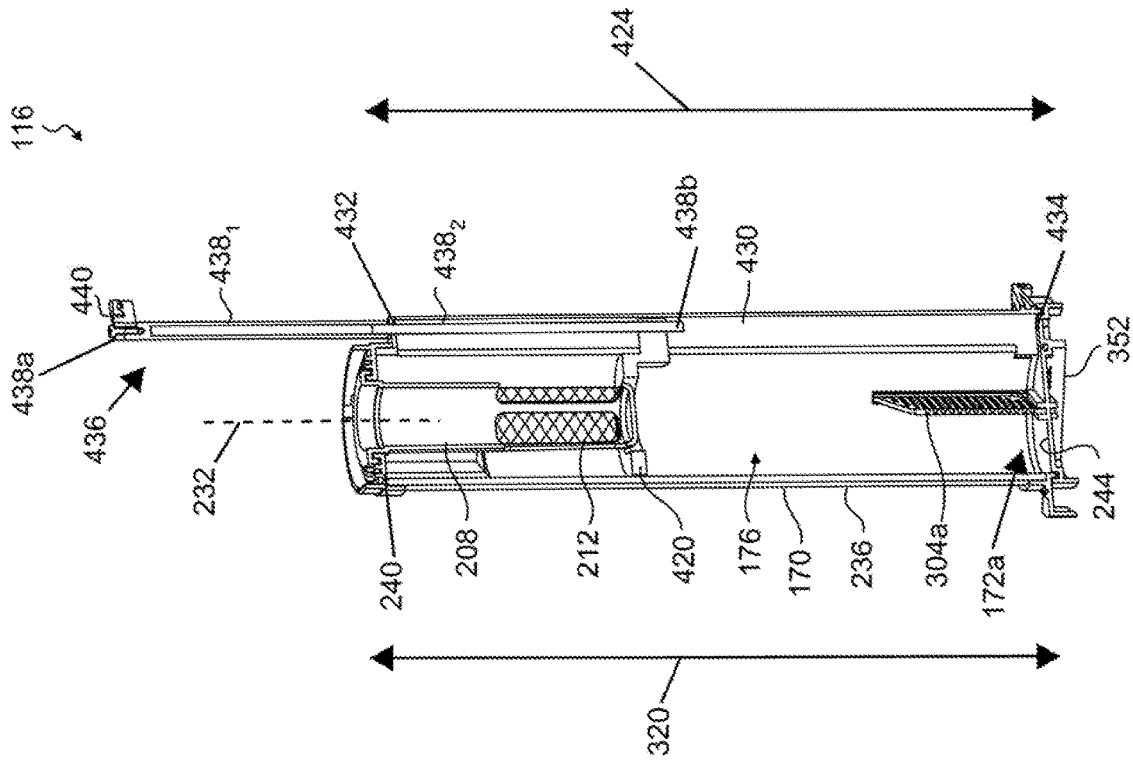

FIG. 88

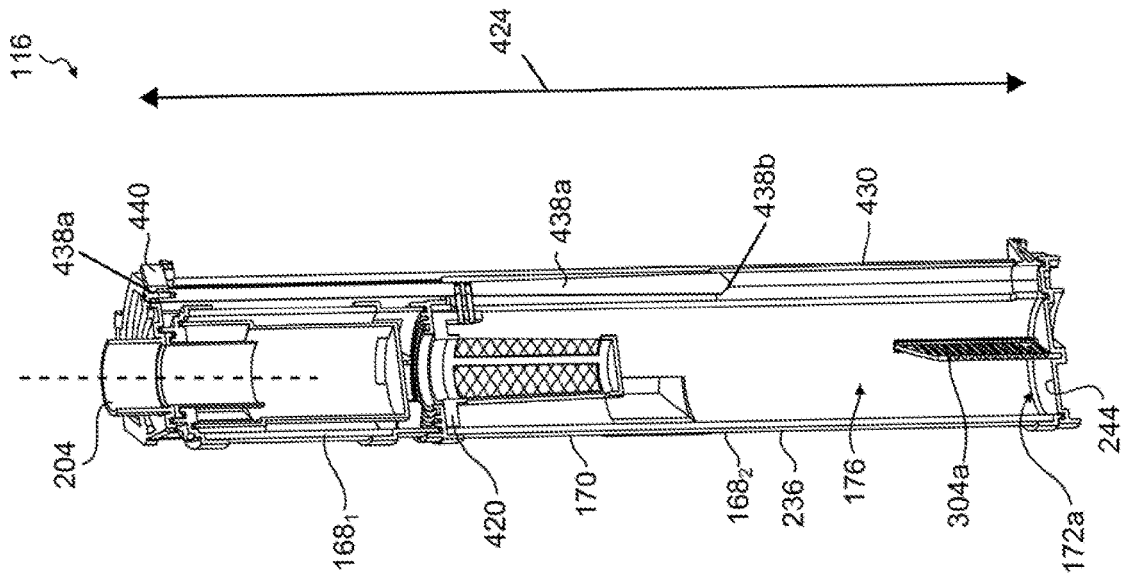

FIG. 89A

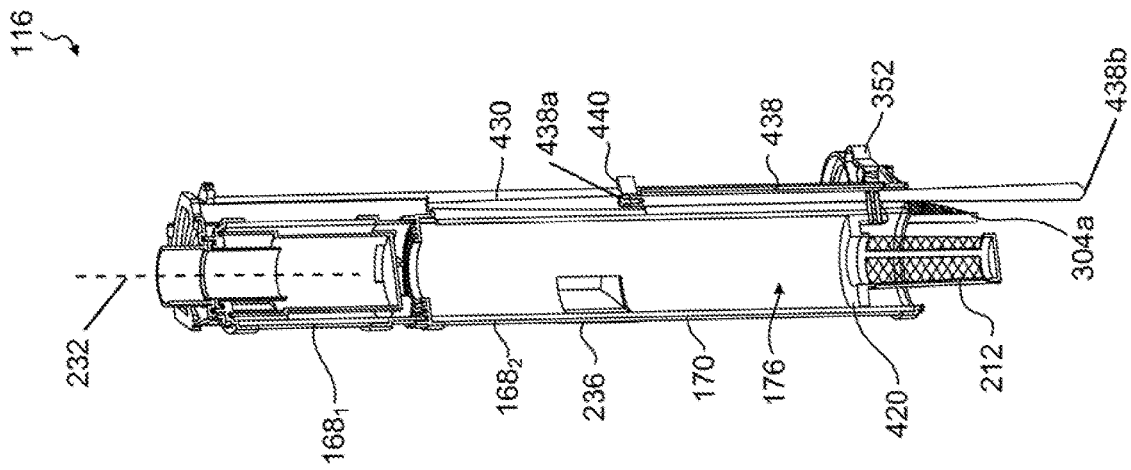

FIG. 89B

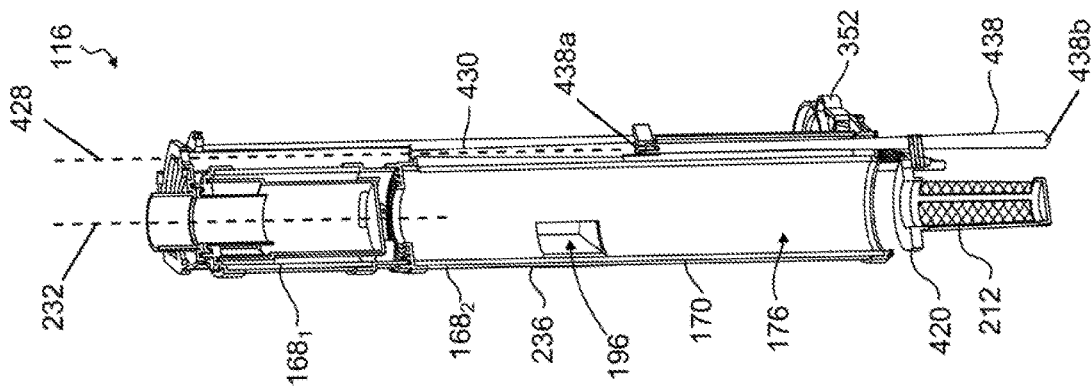

FIG. 89C

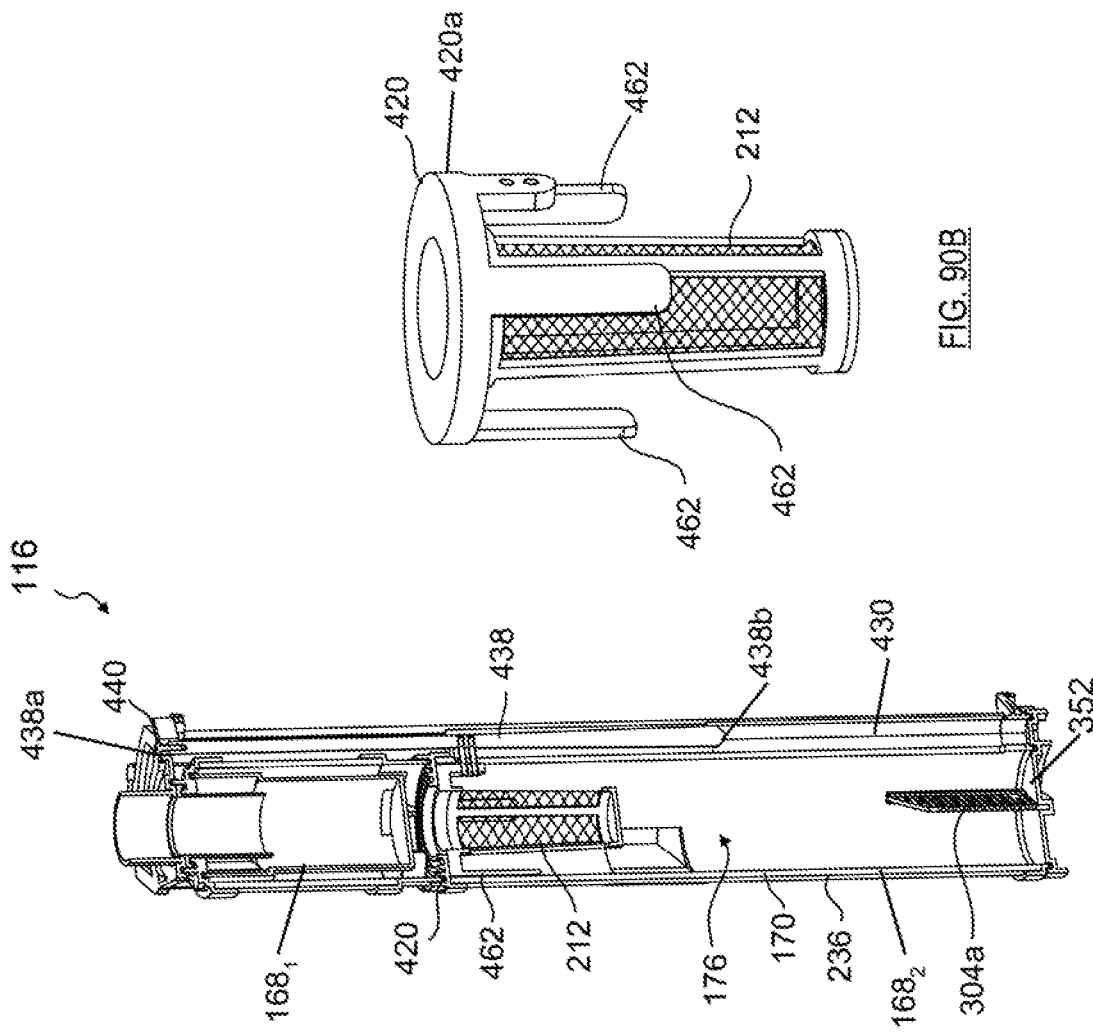

FIG. 90B

FIG. 90A

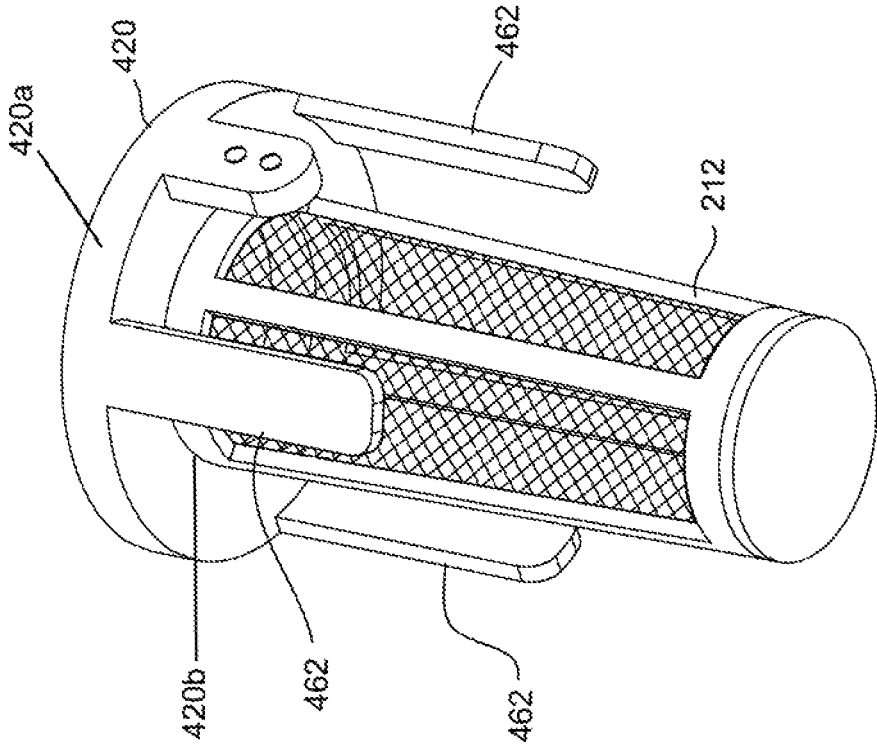

FIG. 90C

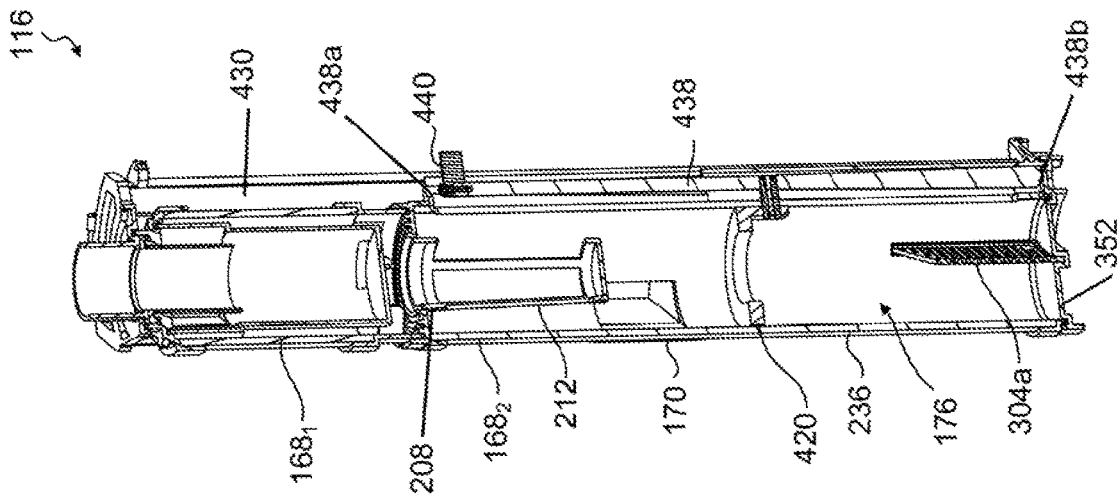
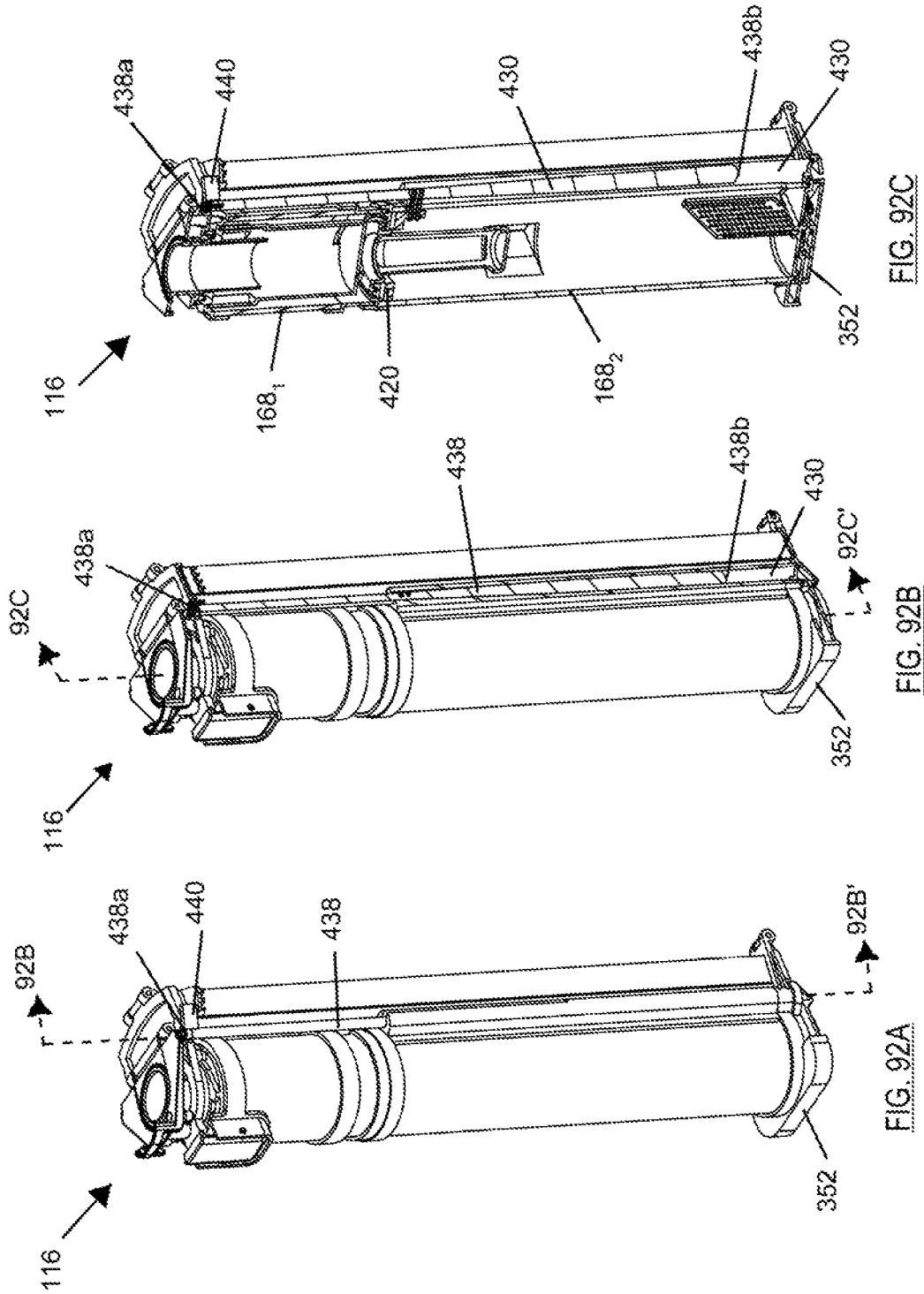

FIG. 91



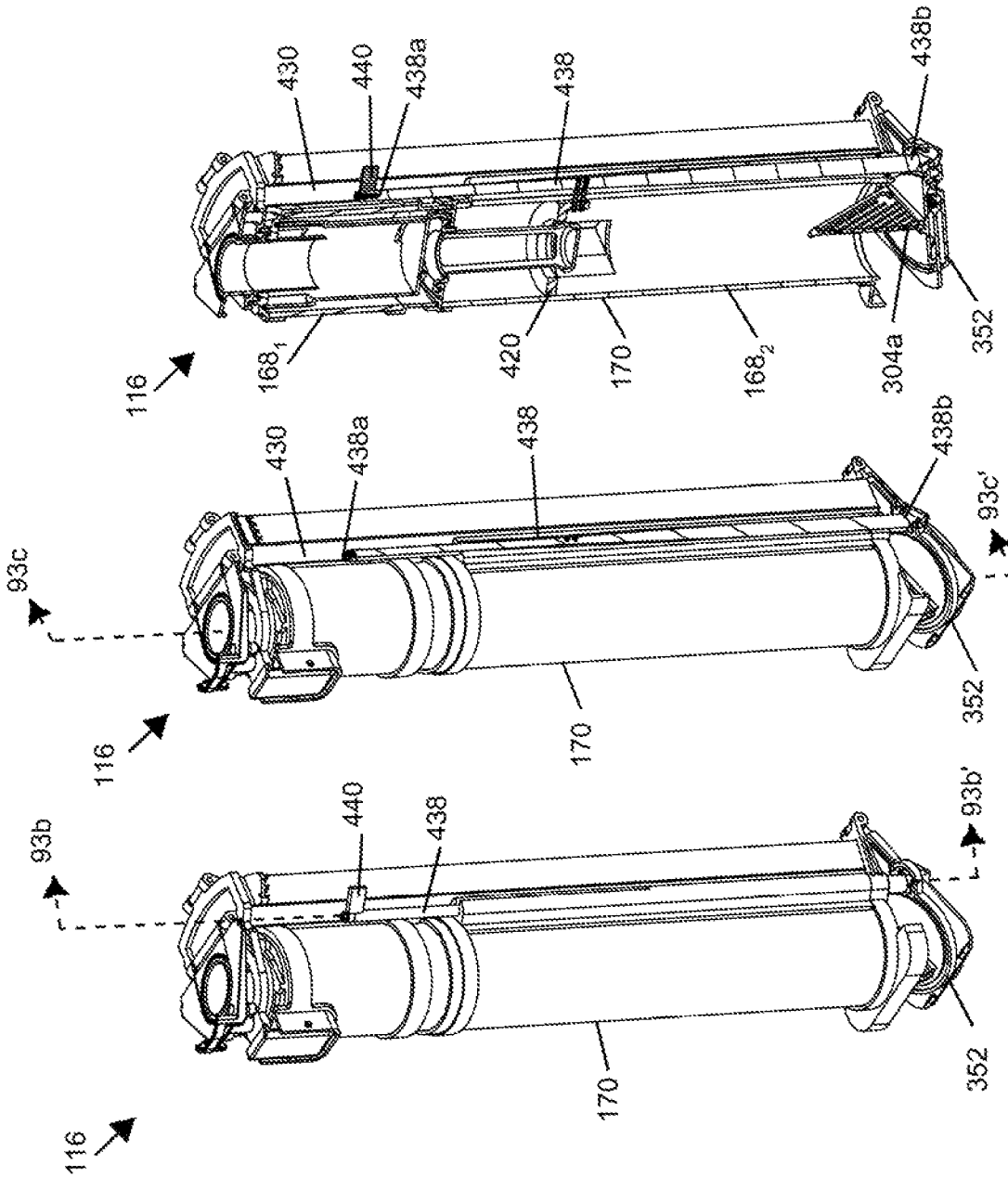

FIG. 93c

FIG. 93b

FIG. 93a

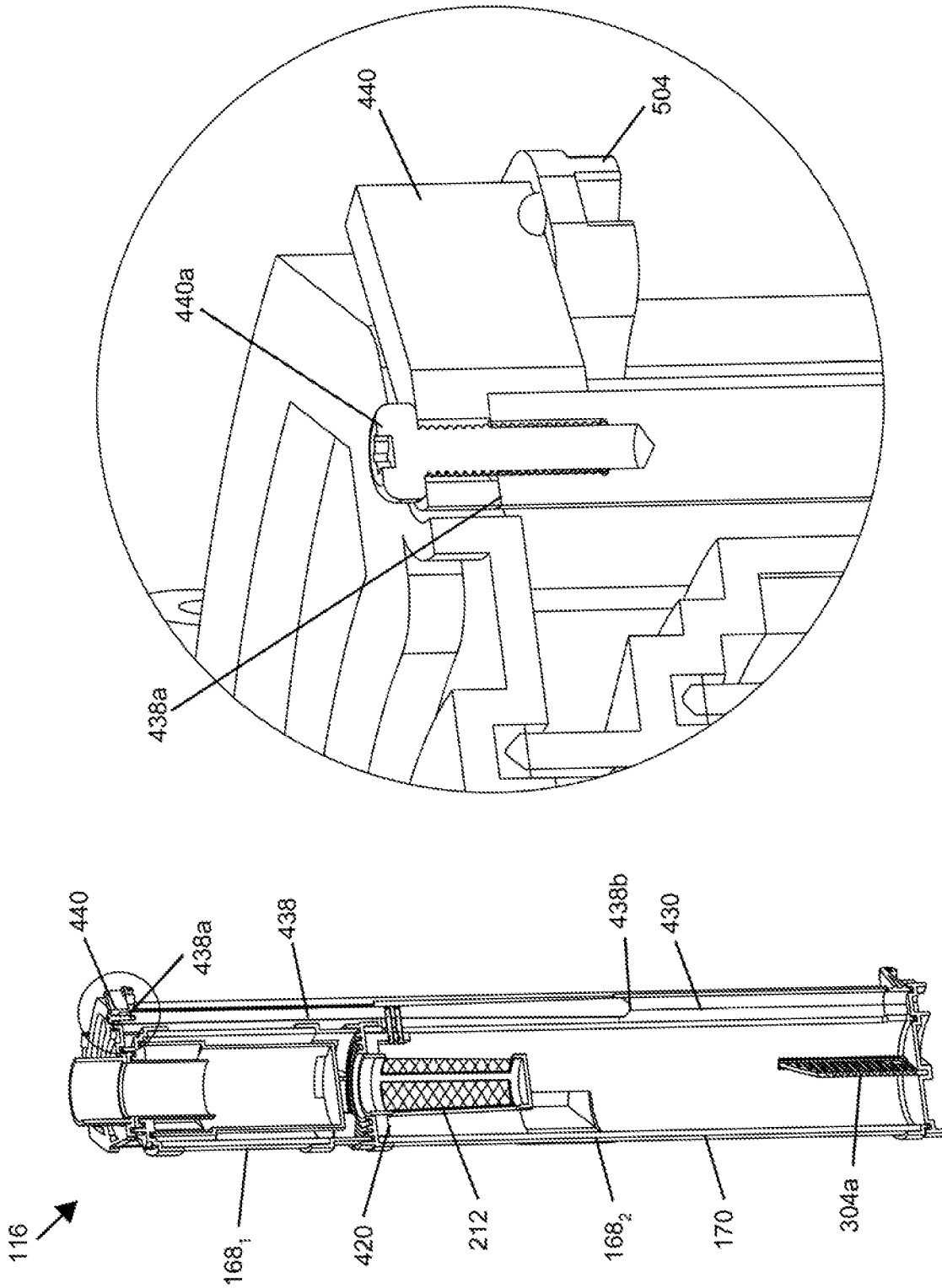

FIG. 94B

FIG. 94A

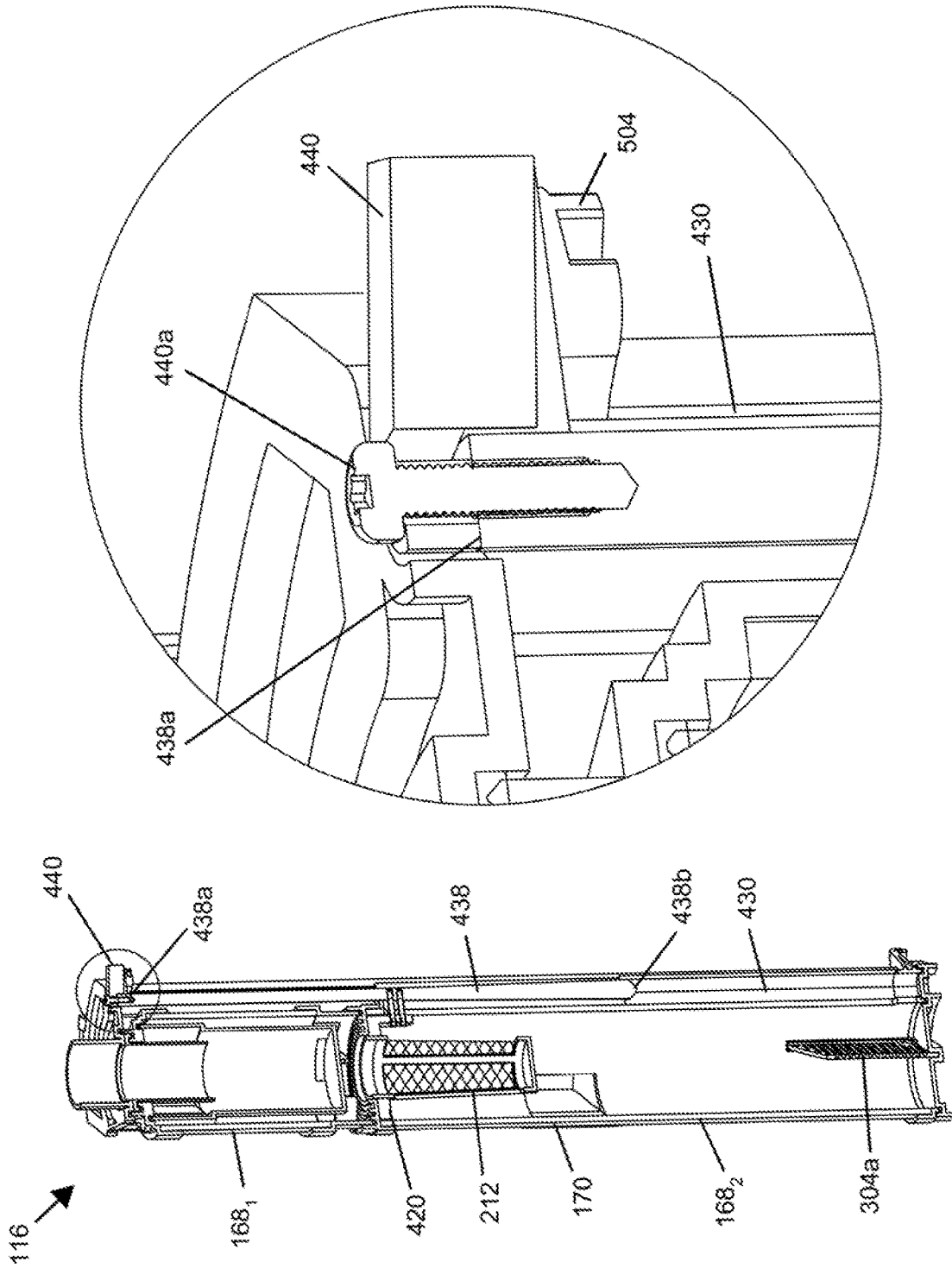

FIG. 95B

FIG. 95A

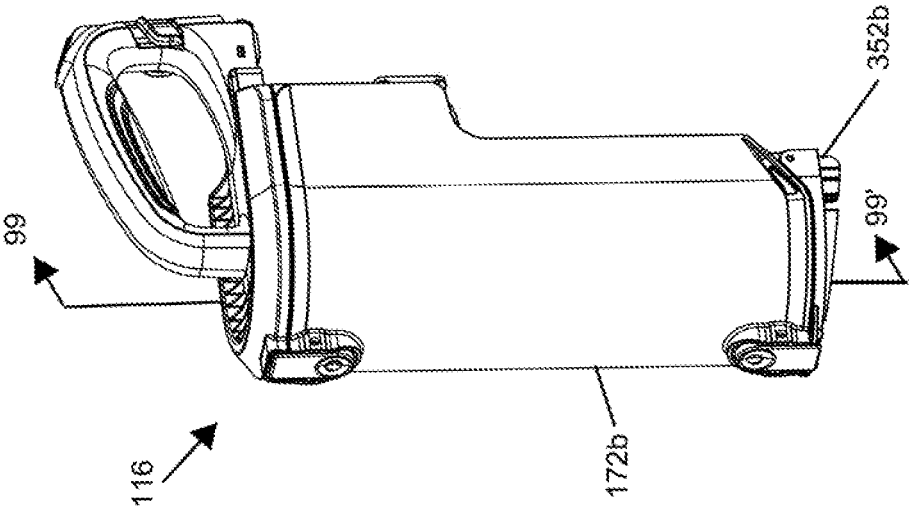

FIG. 96

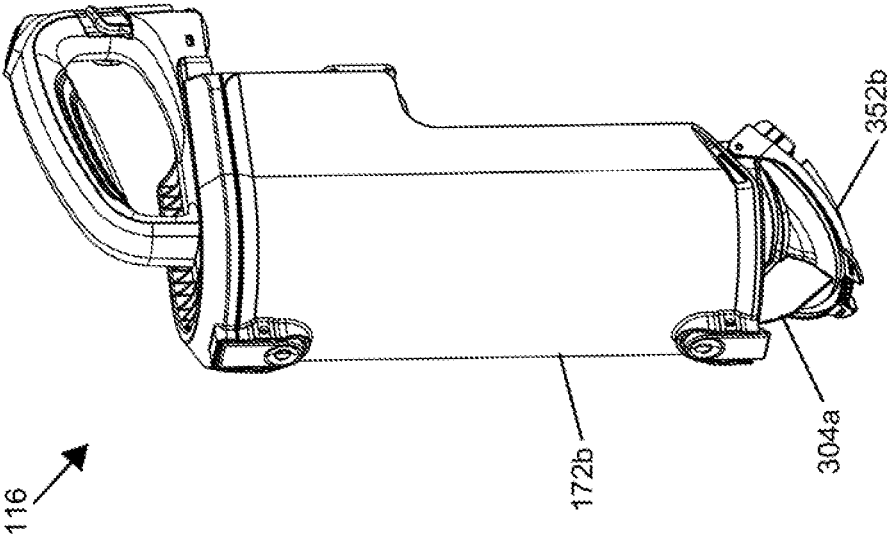

FIG. 97

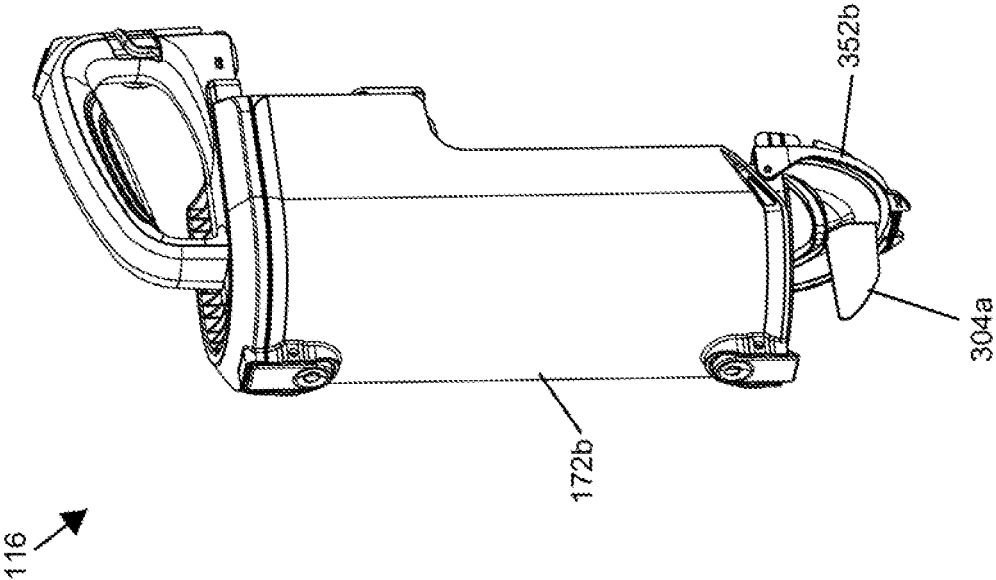

FIG. 98

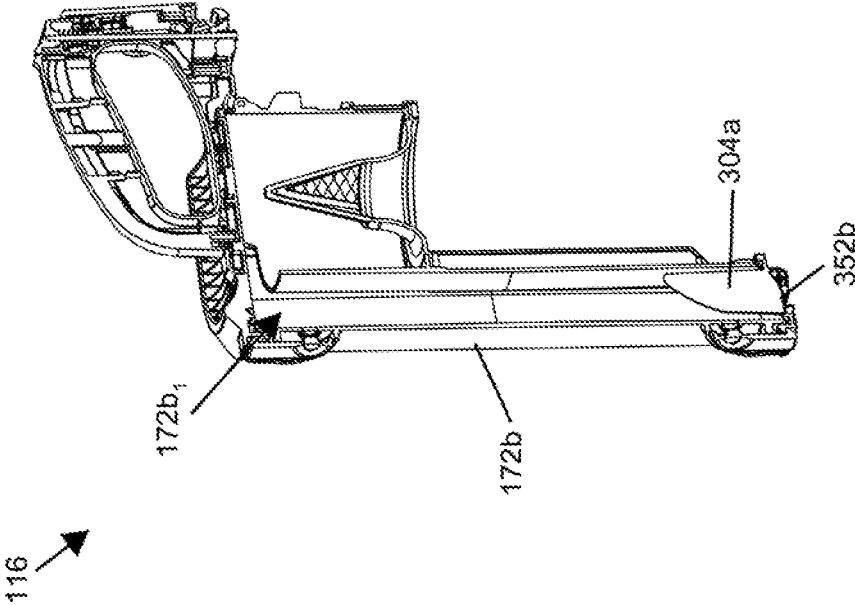

FIG. 99

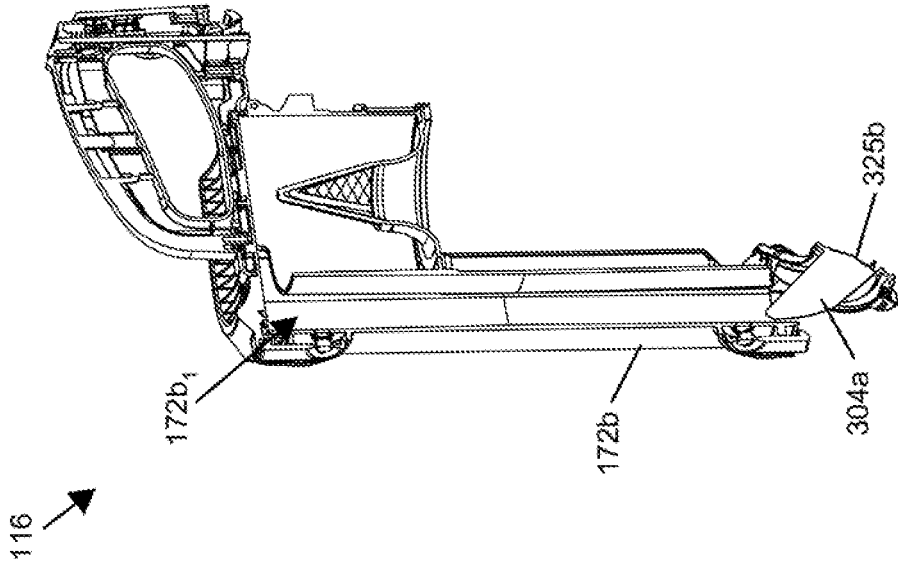

FIG. 100

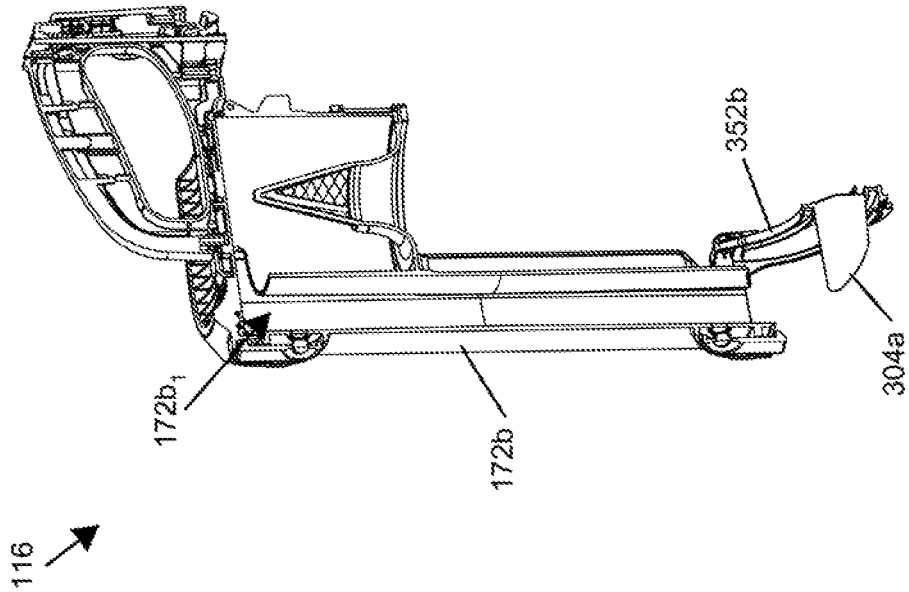
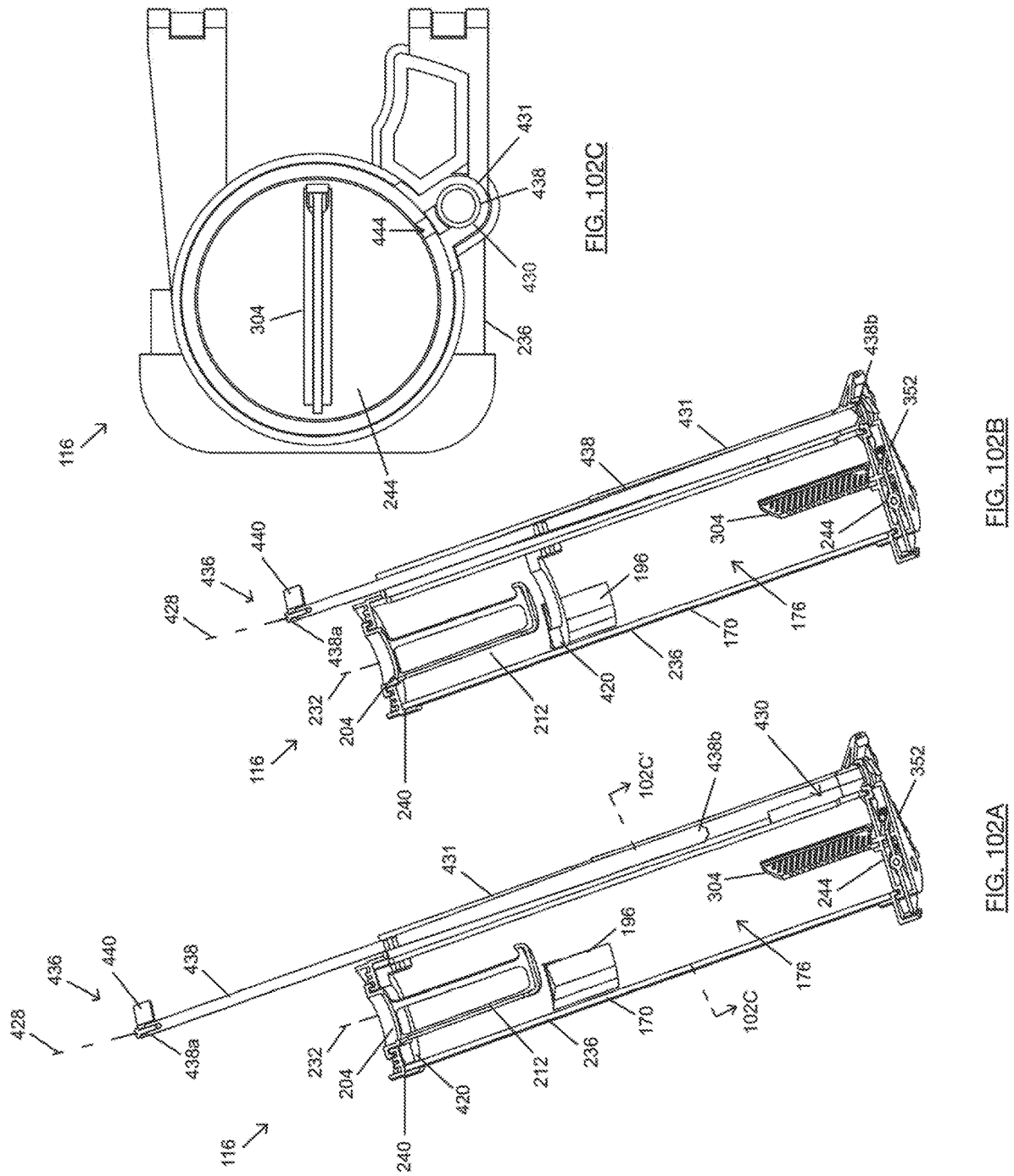
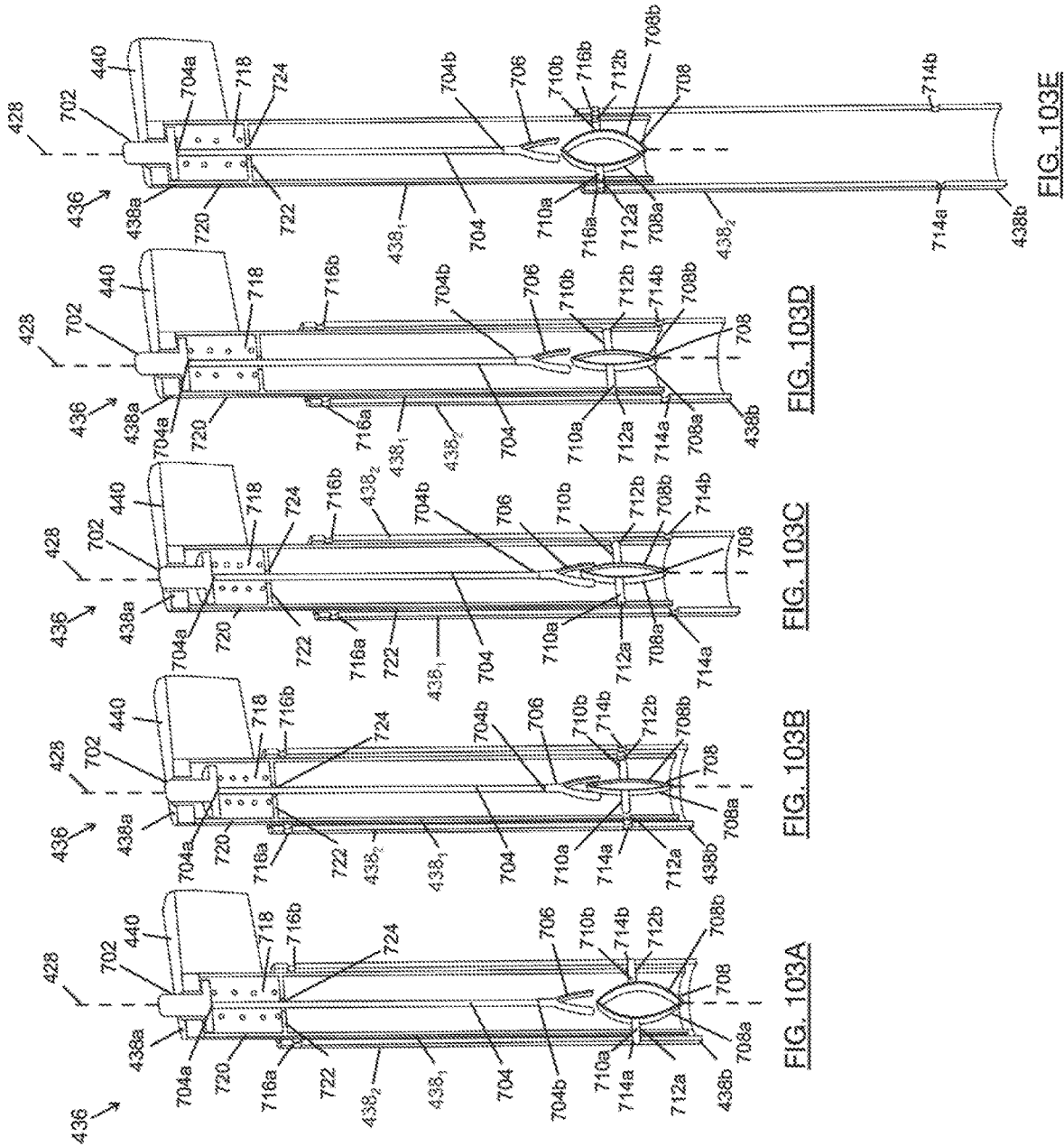

FIG. 101





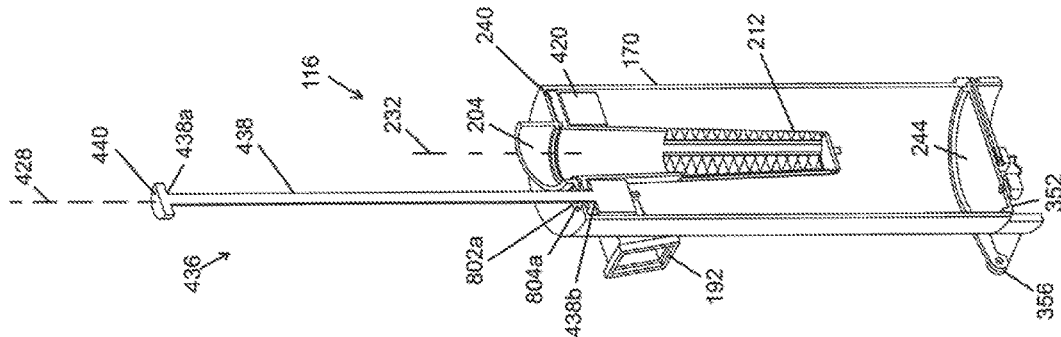

FIG. 105

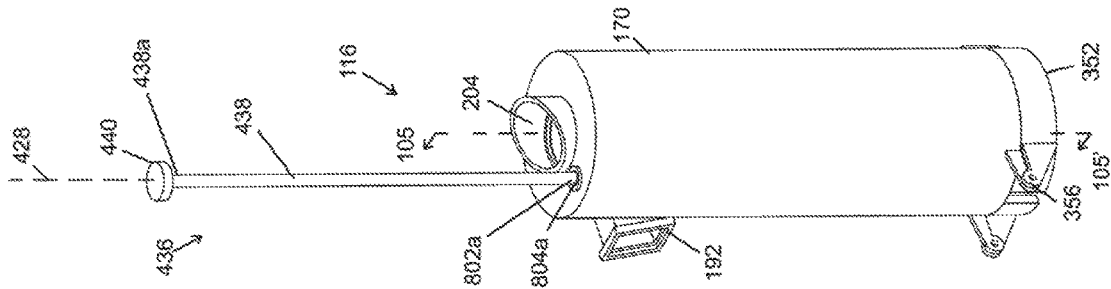

FIG. 104A

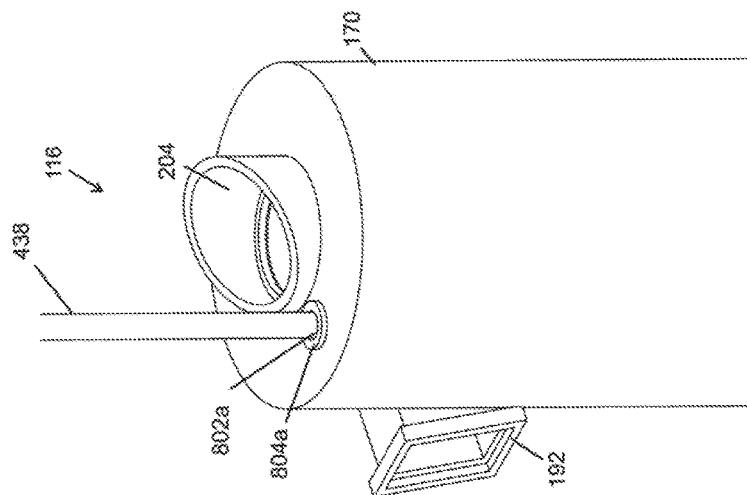

FIG. 104B

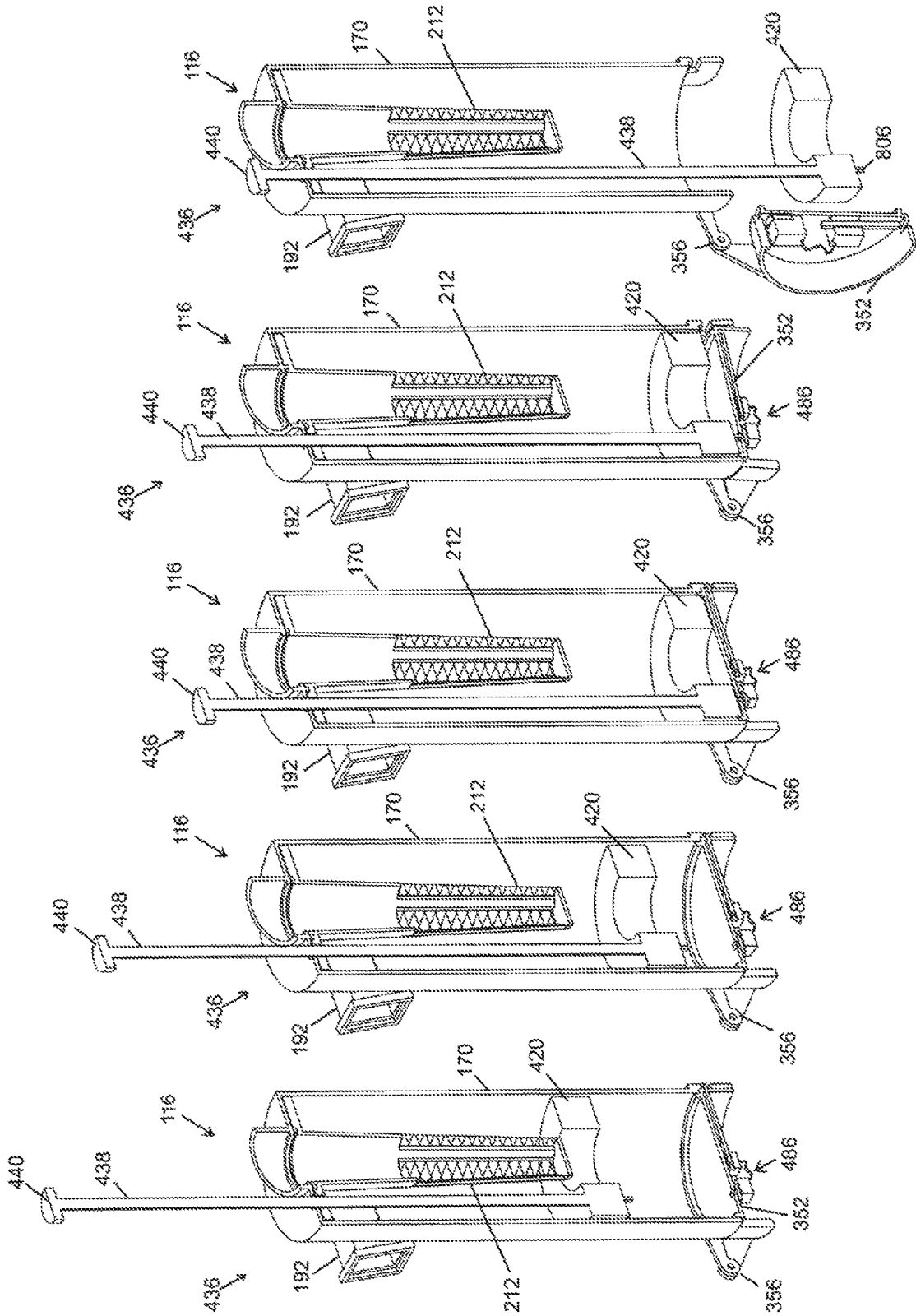

FIG. 106E

FIG. 106D

FIG. 106C

FIG. 106B

FIG. 106A

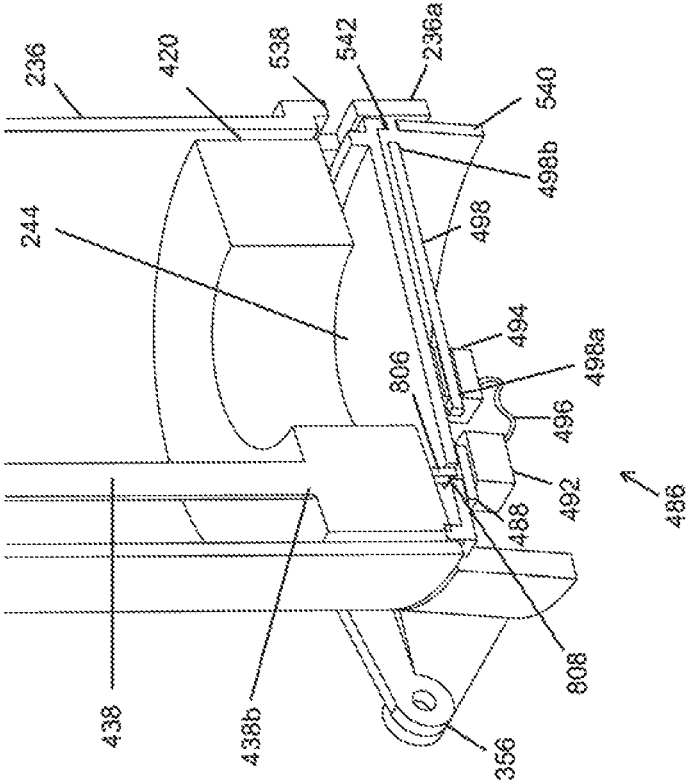

FIG. 107A

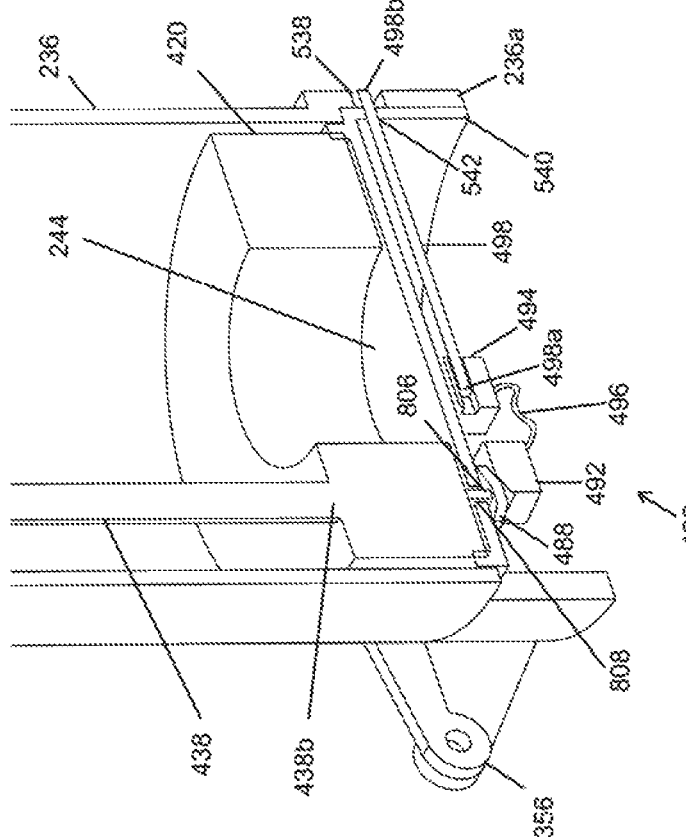

FIG. 107B

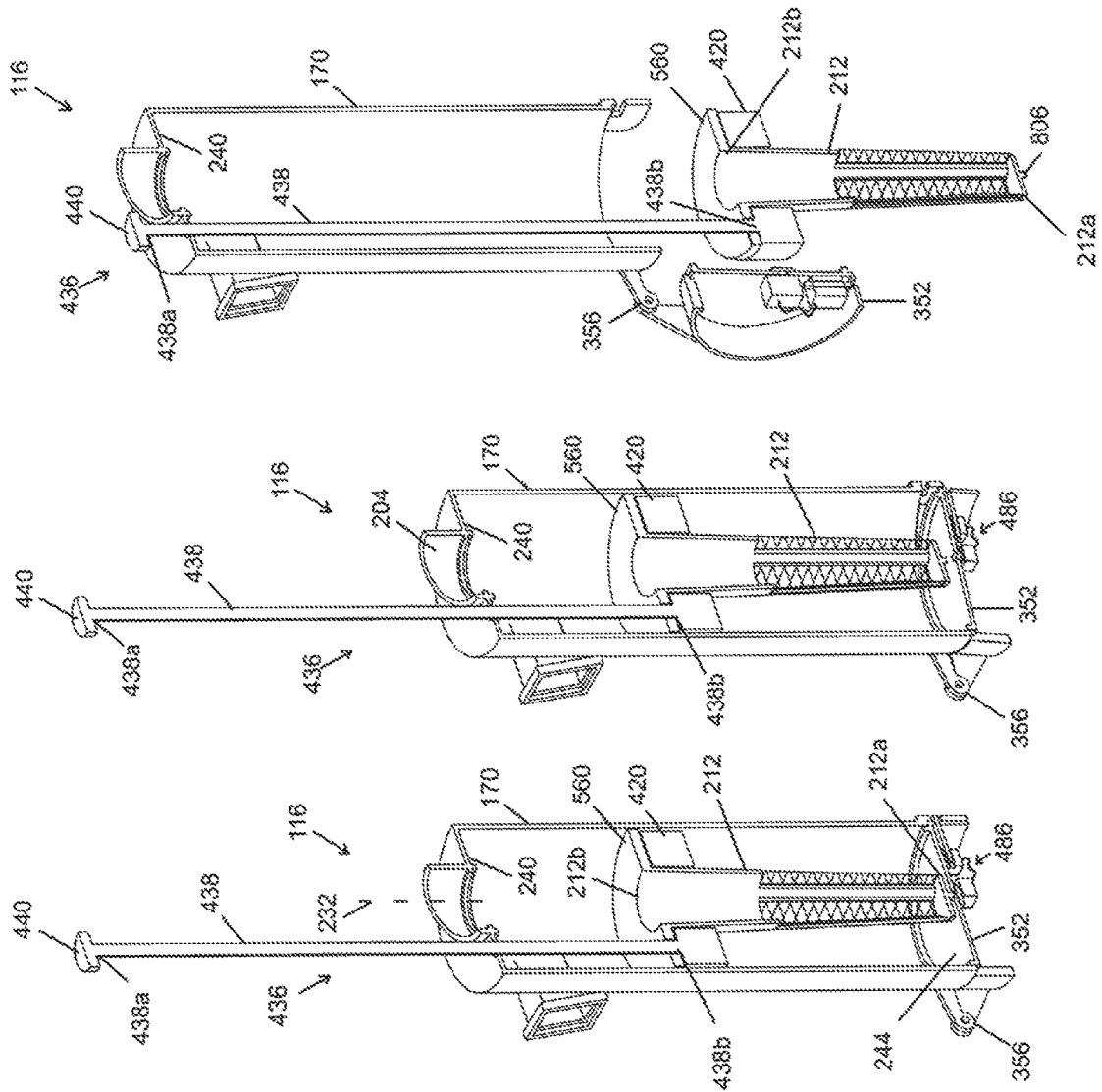

FIG. 108C

FIG. 108B

FIG. 108A

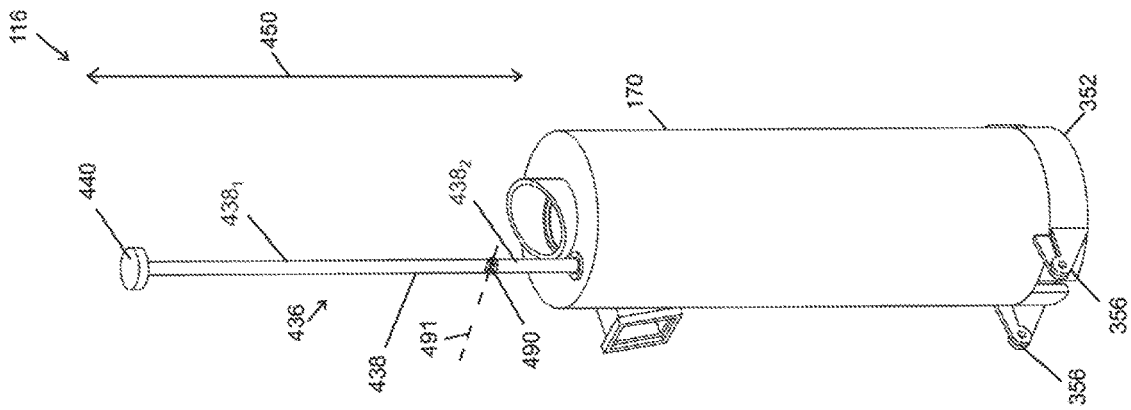

FIG. 109B

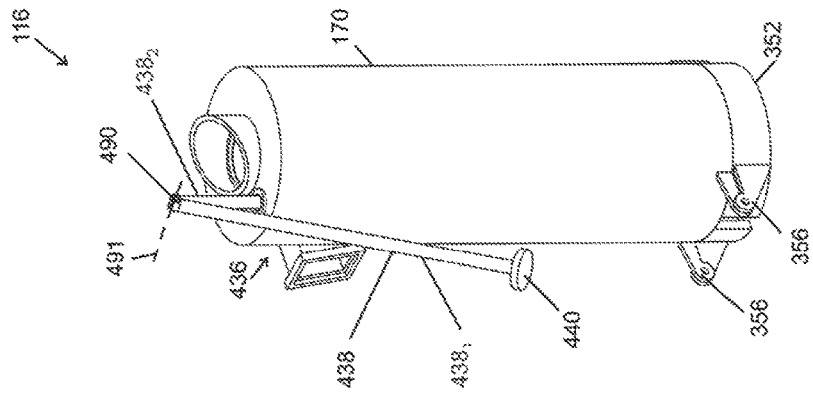

FIG. 109A

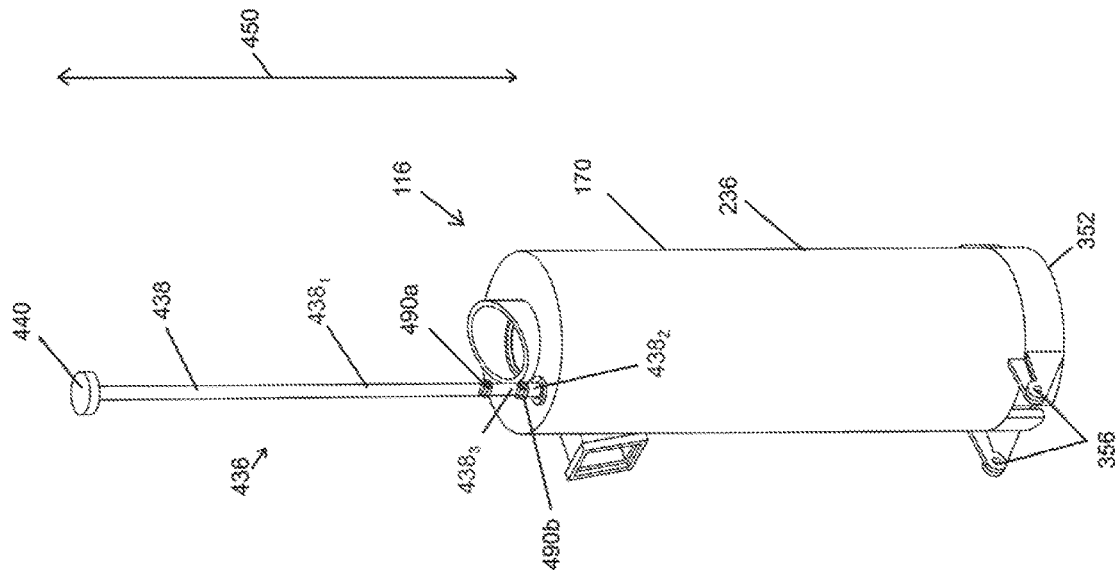

FIG. 110B

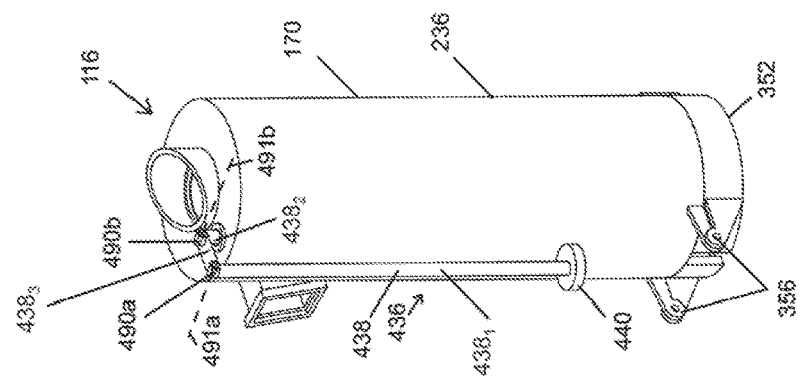

FIG. 110A

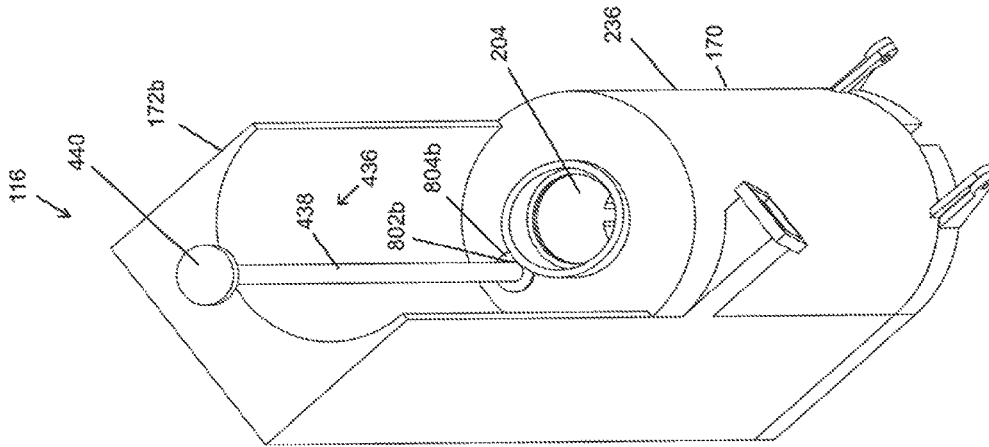

FIG. 111C

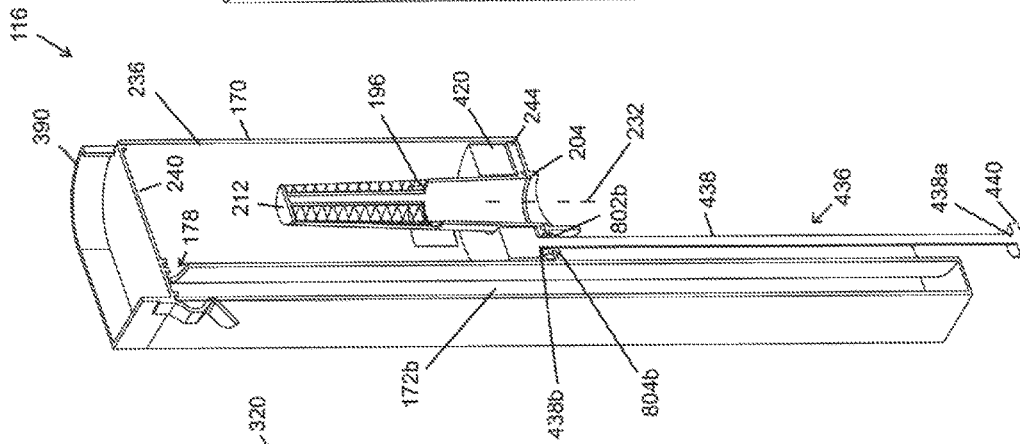

FIG. 111B

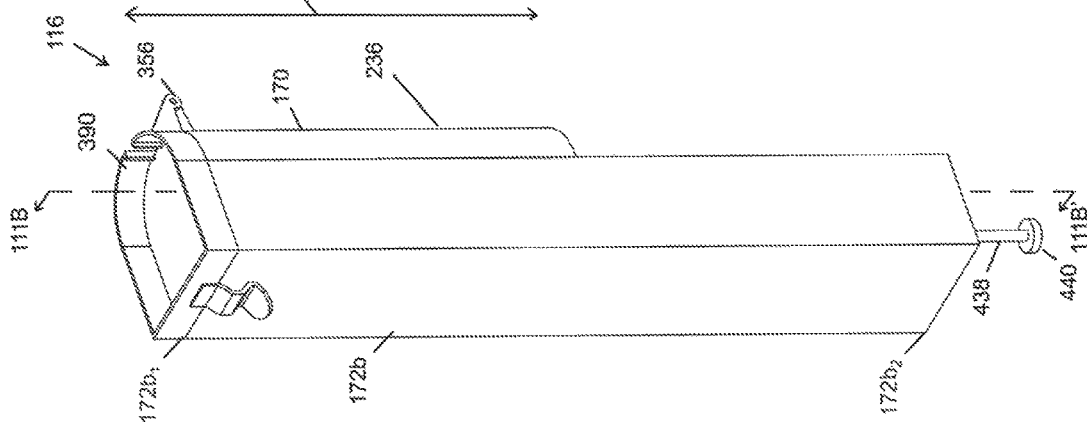

FIG. 111A

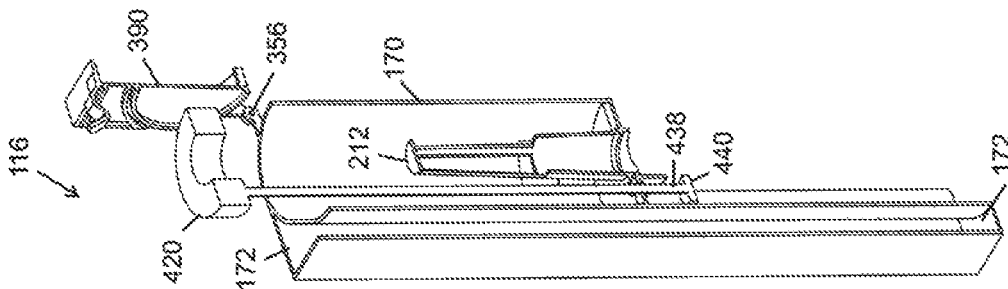

FIG. 112A

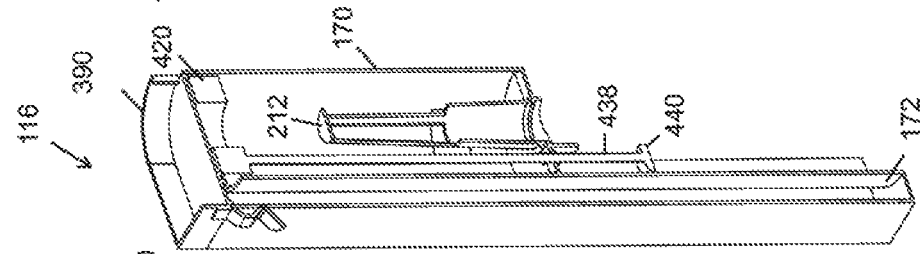

FIG. 112B

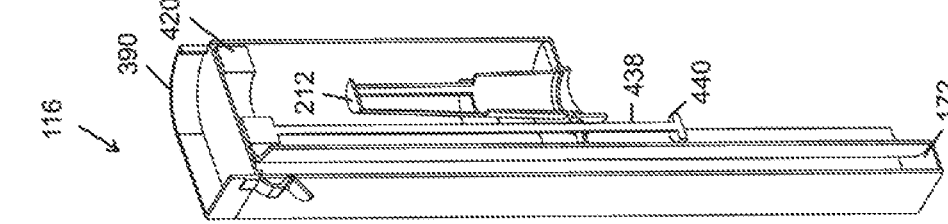

FIG. 112C

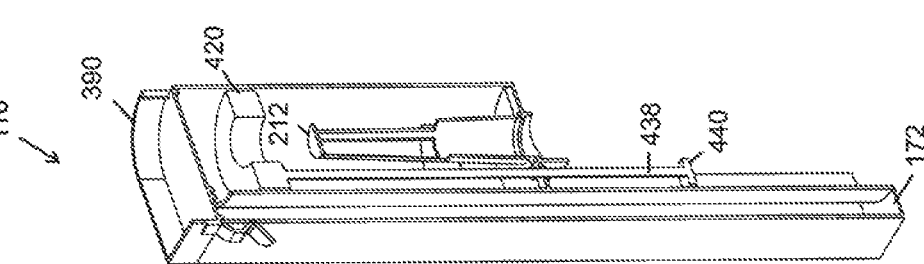

FIG. 112D

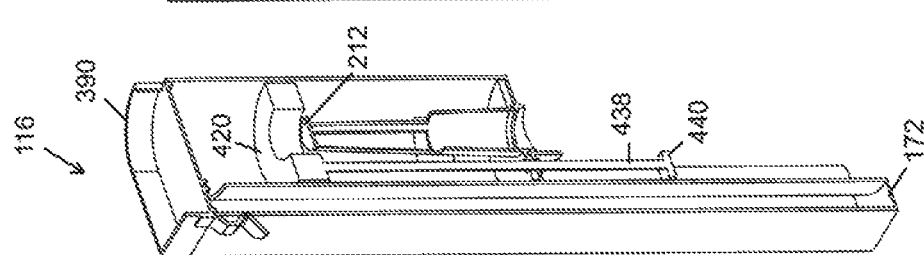

FIG. 112E

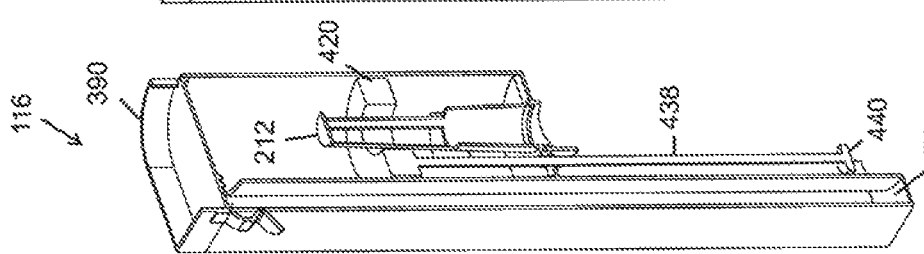

FIG. 112F

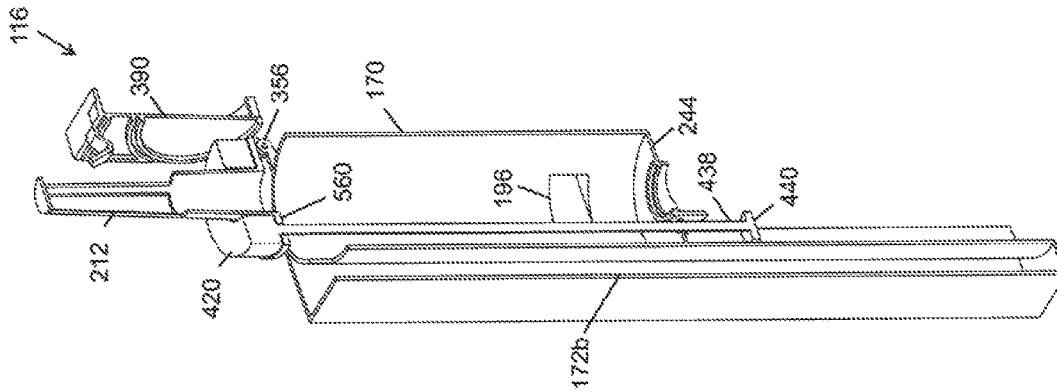

FIG. 113C

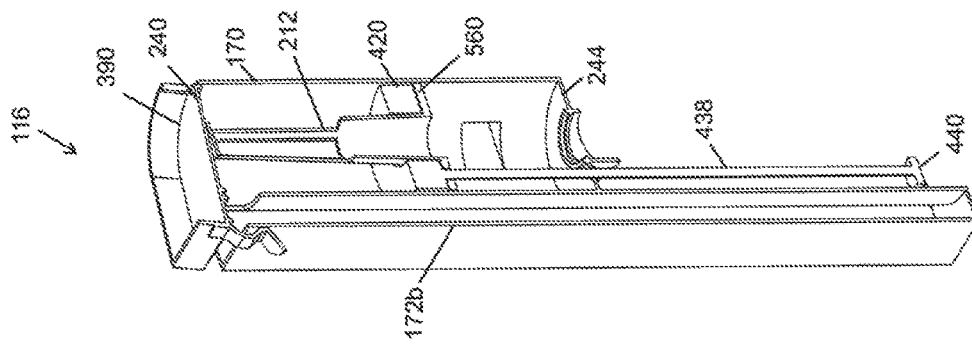

FIG. 113B

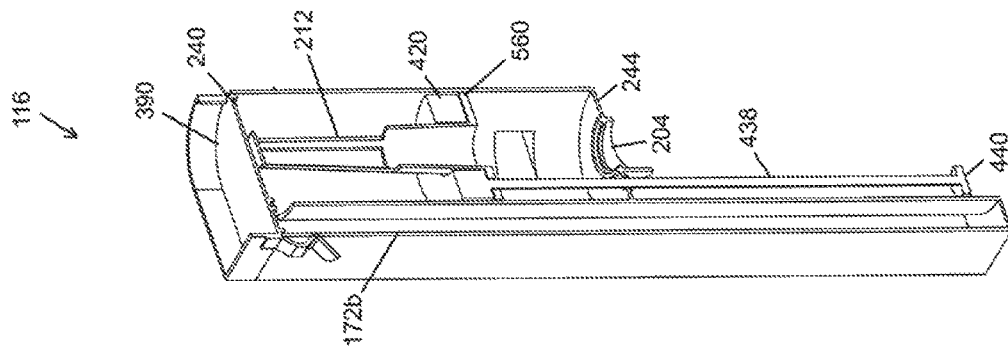
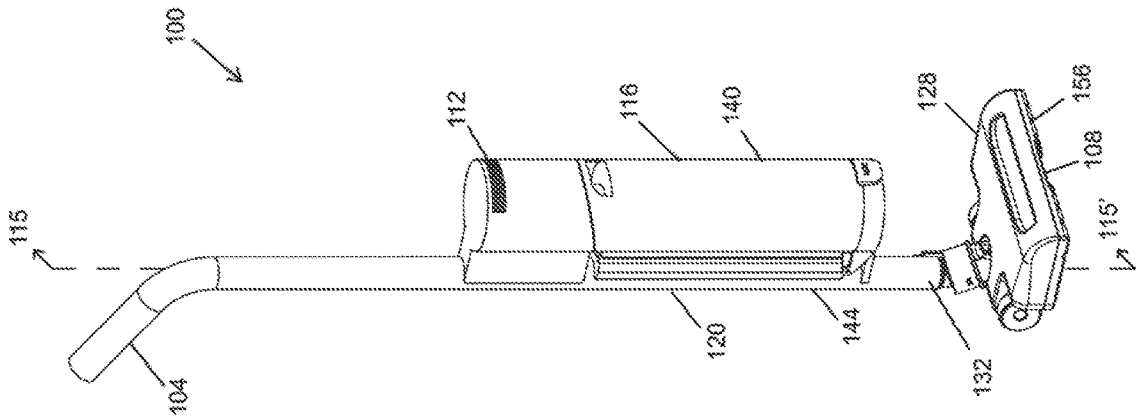
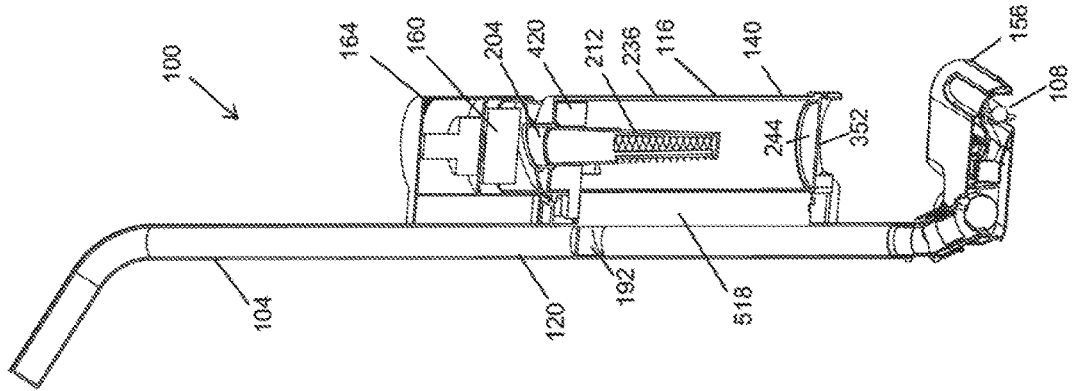

FIG. 113A



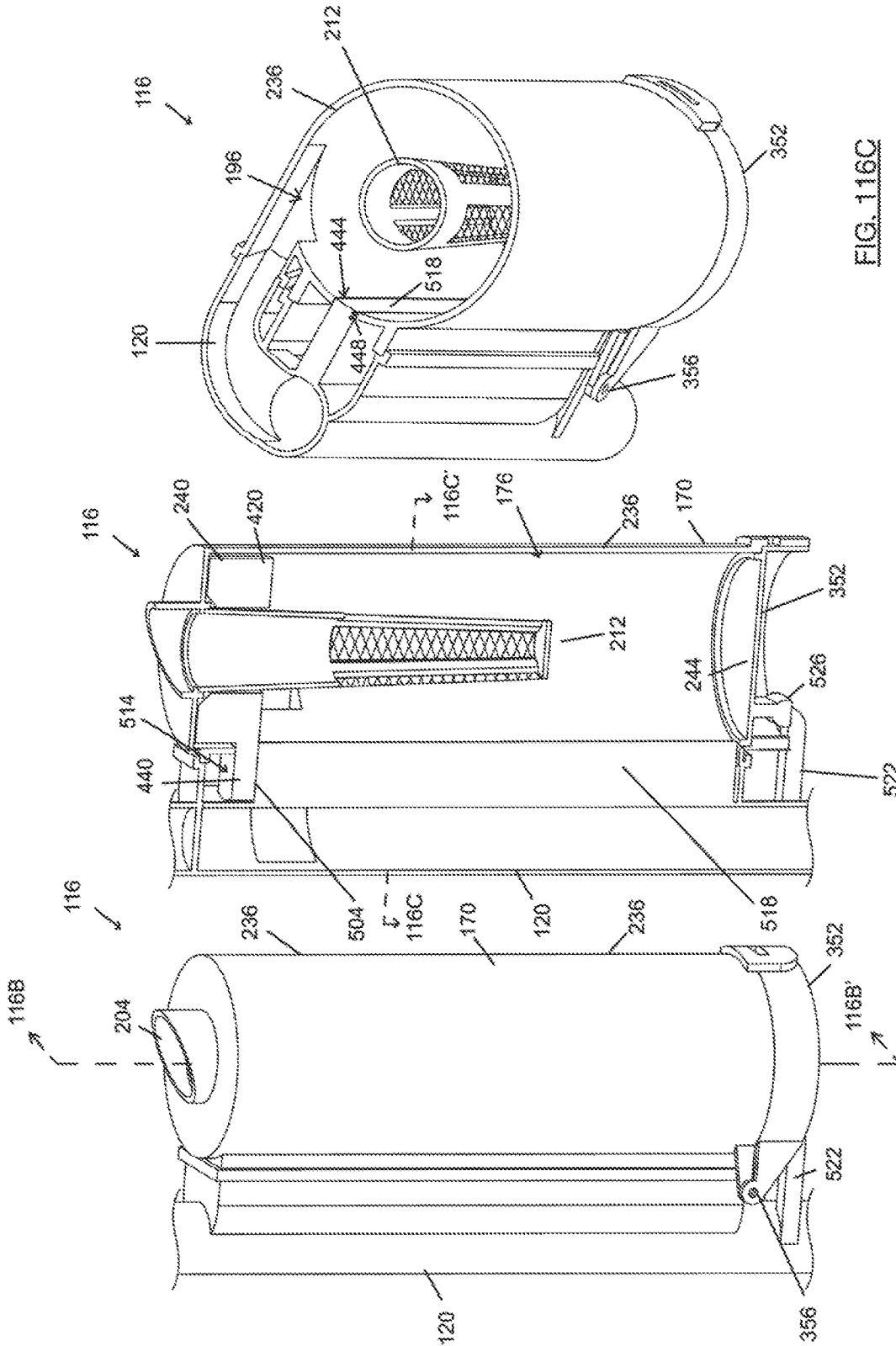

FIG. 116A

FIG. 116B

FIG. 116C

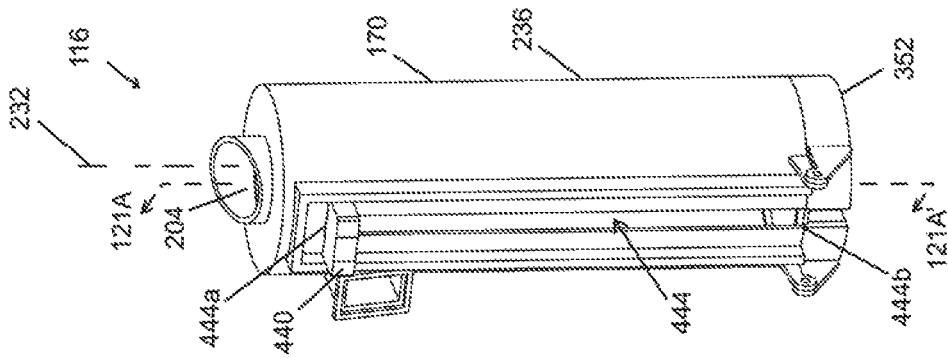

FIG. 117C

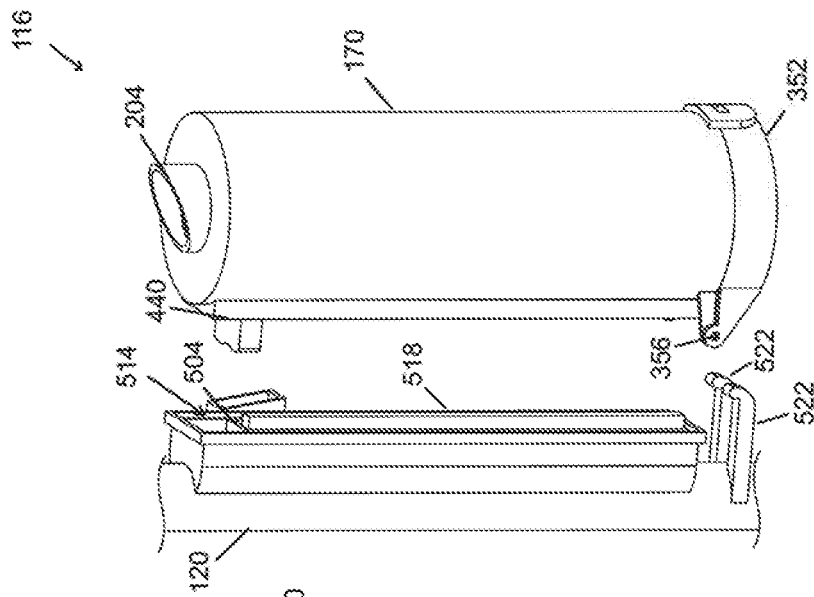

FIG. 117B

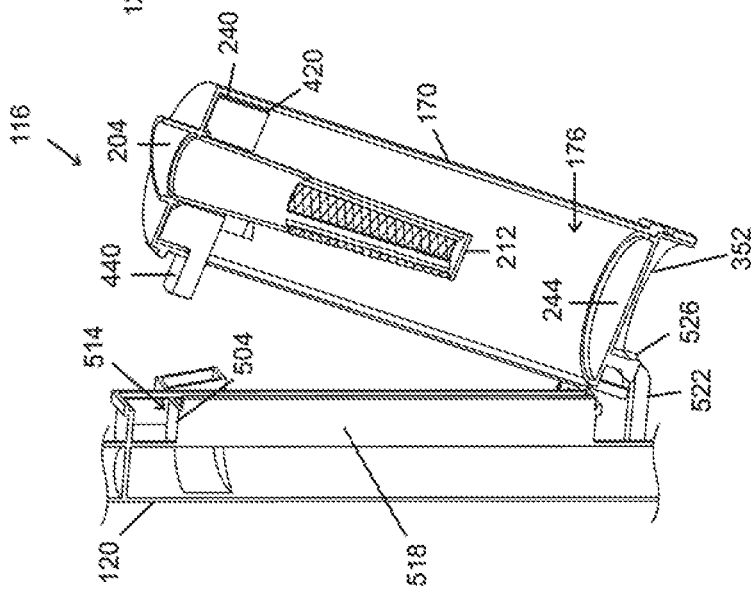

FIG. 117A

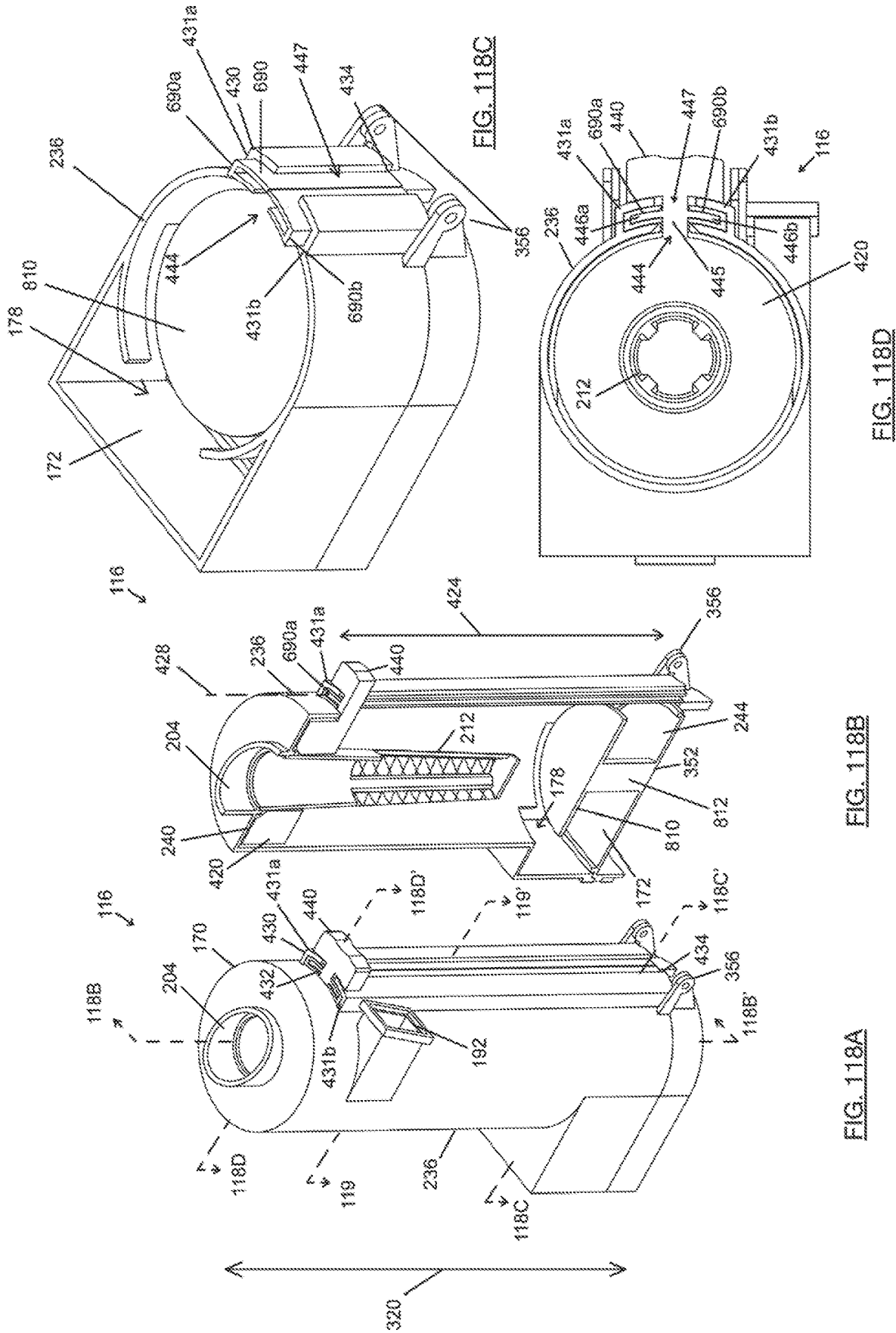

FIG. 118C

FIG. 118D

FIG. 118B

FIG. 118A

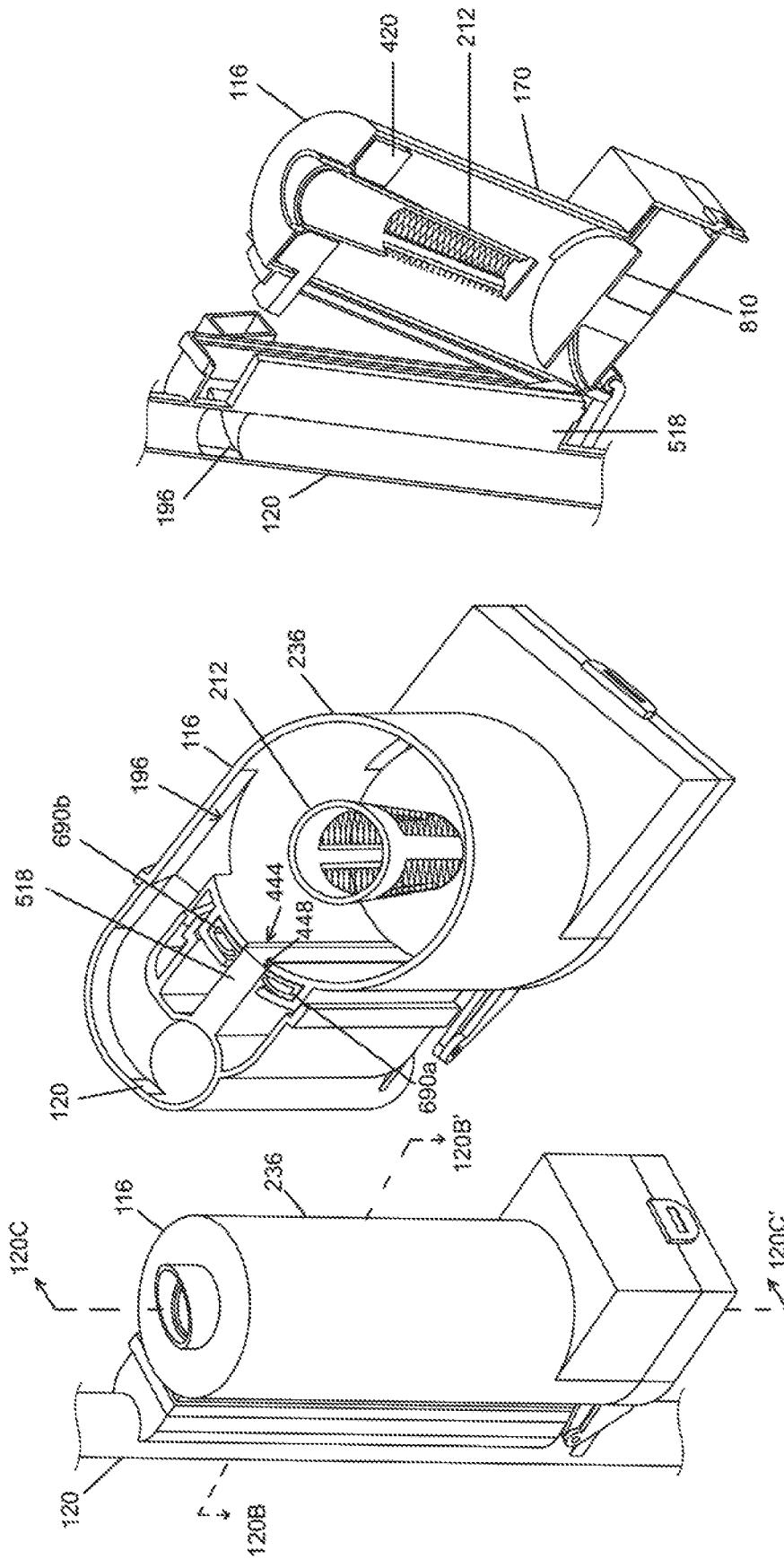

FIG. 120C

FIG. 120B

FIG. 120A

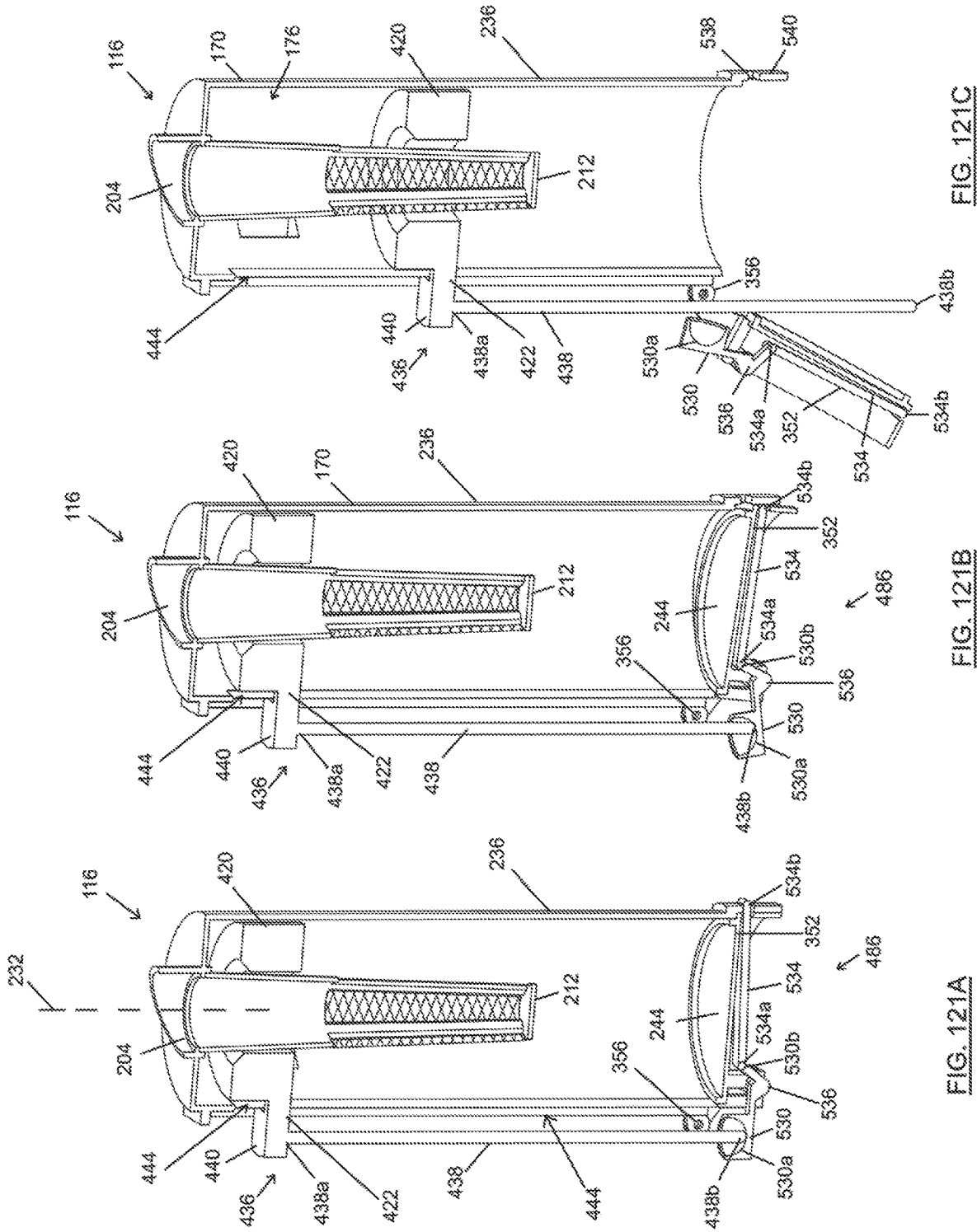

FIG. 121C

FIG. 121B

FIG. 121A

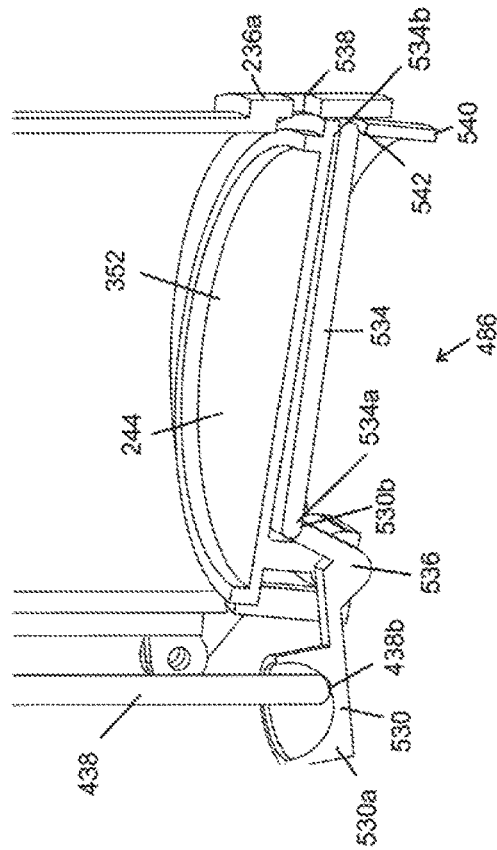

FIG. 122B

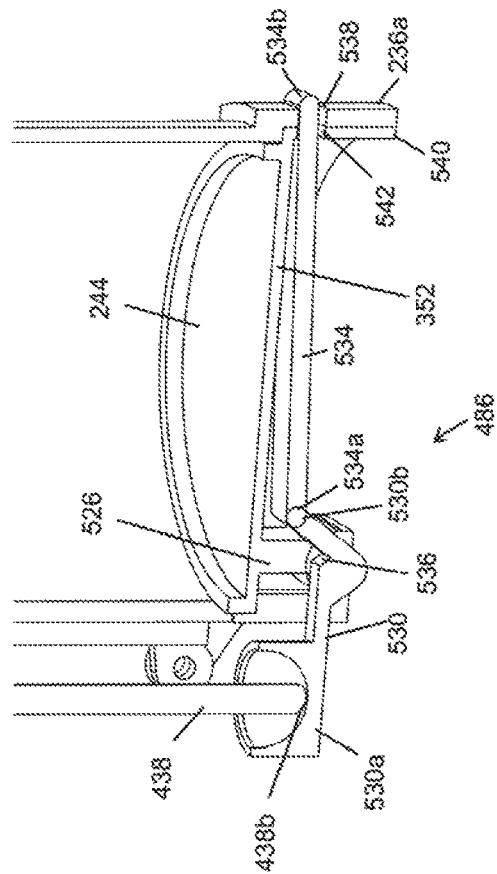

FIG. 122A

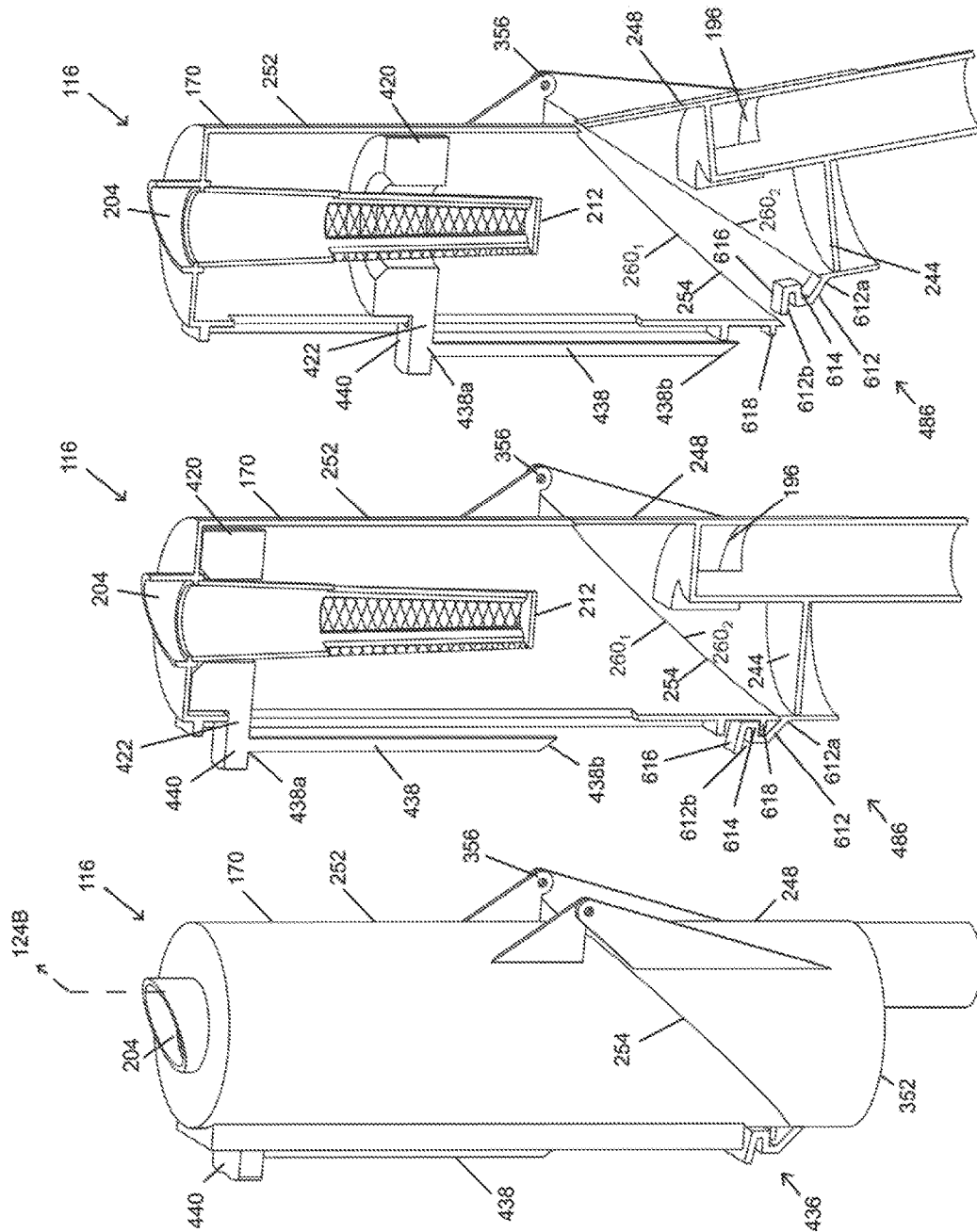

FIG. 124C

FIG. 124B

FIG. 124A

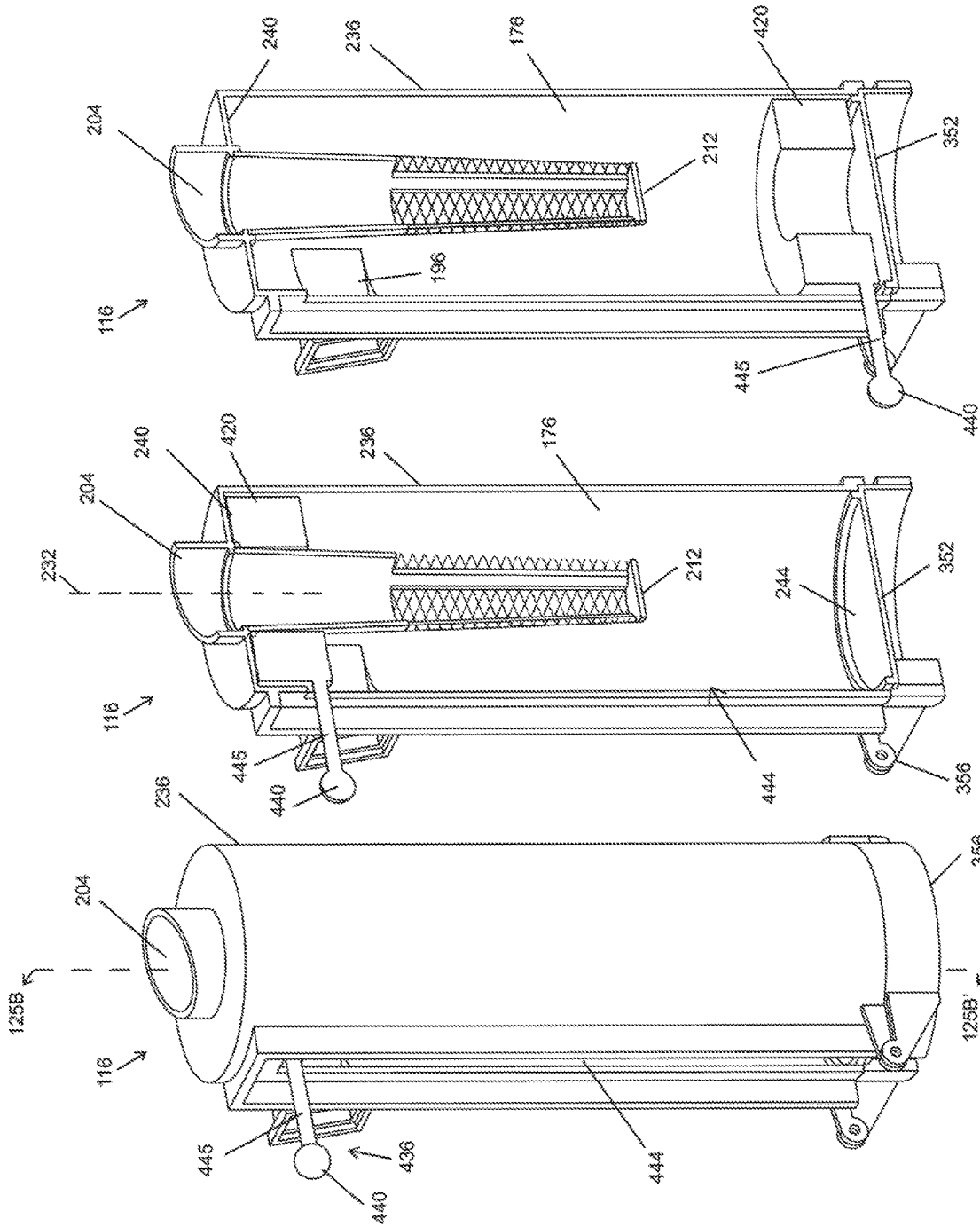

FIG. 125C

FIG. 125B

FIG. 125A

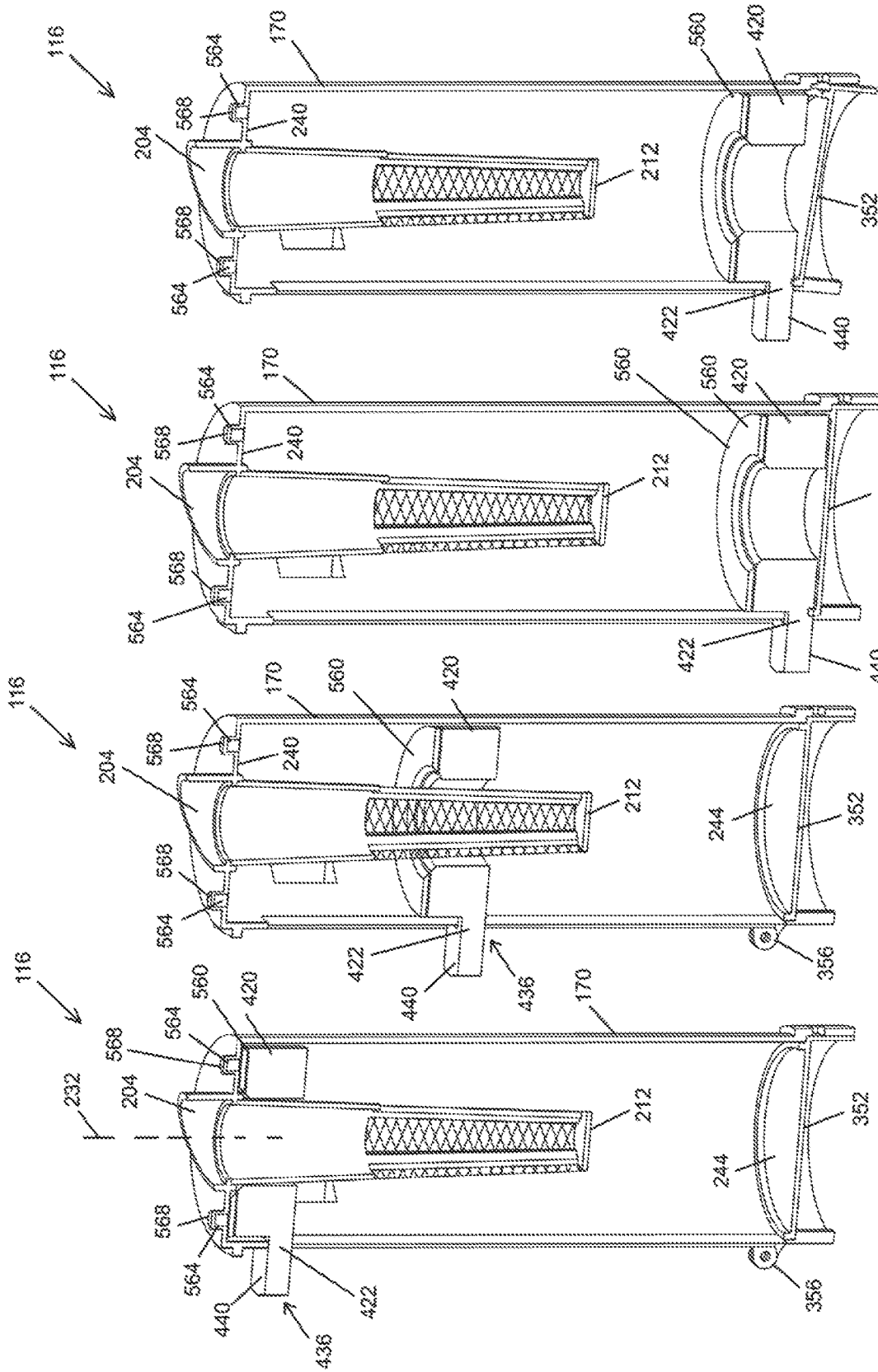

FIG. 126A

FIG. 126B

FIG. 126C

FIG. 126D

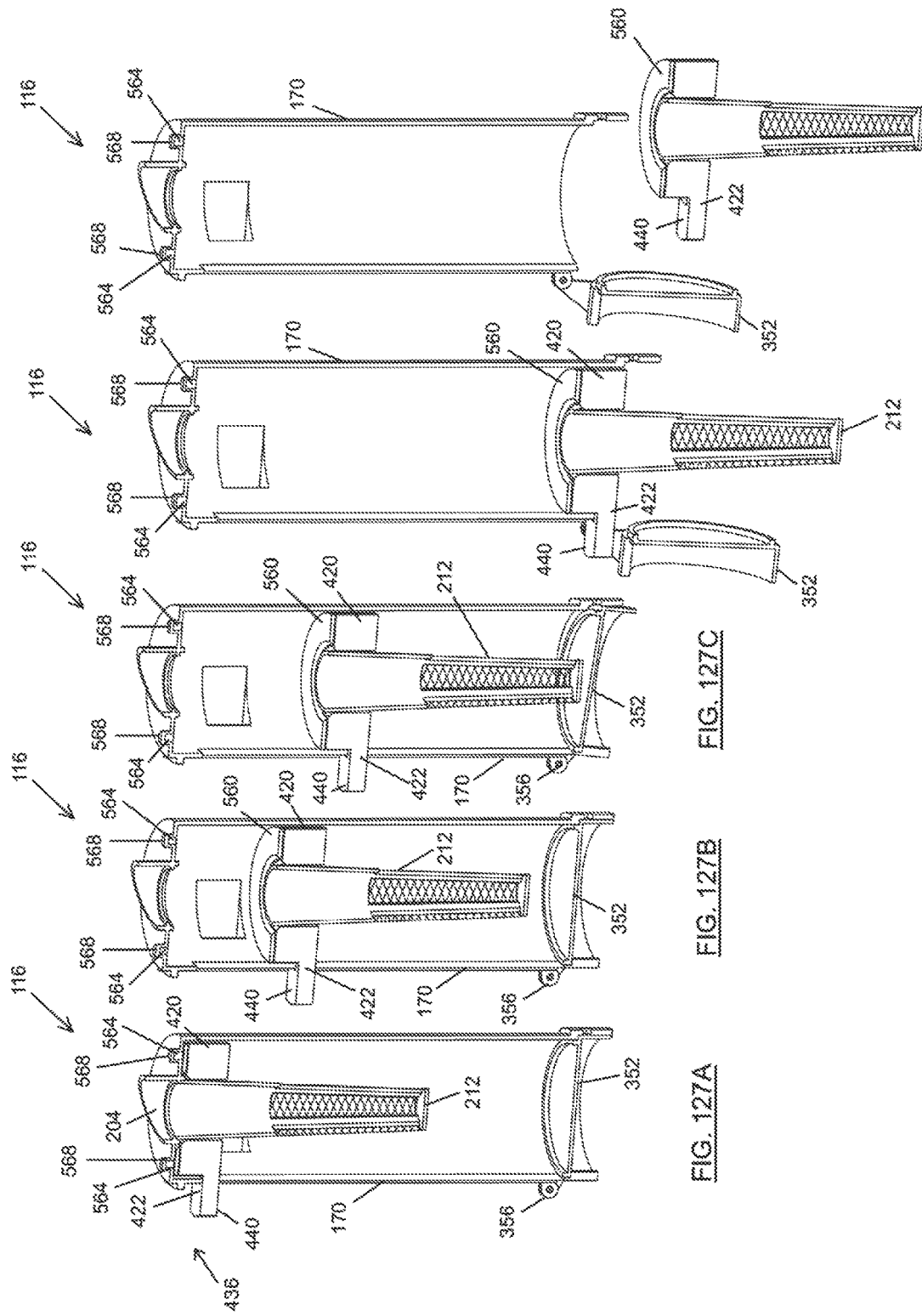

FIG. 127A

FIG. 127B

FIG. 127C

FIG. 127D

FIG. 127E

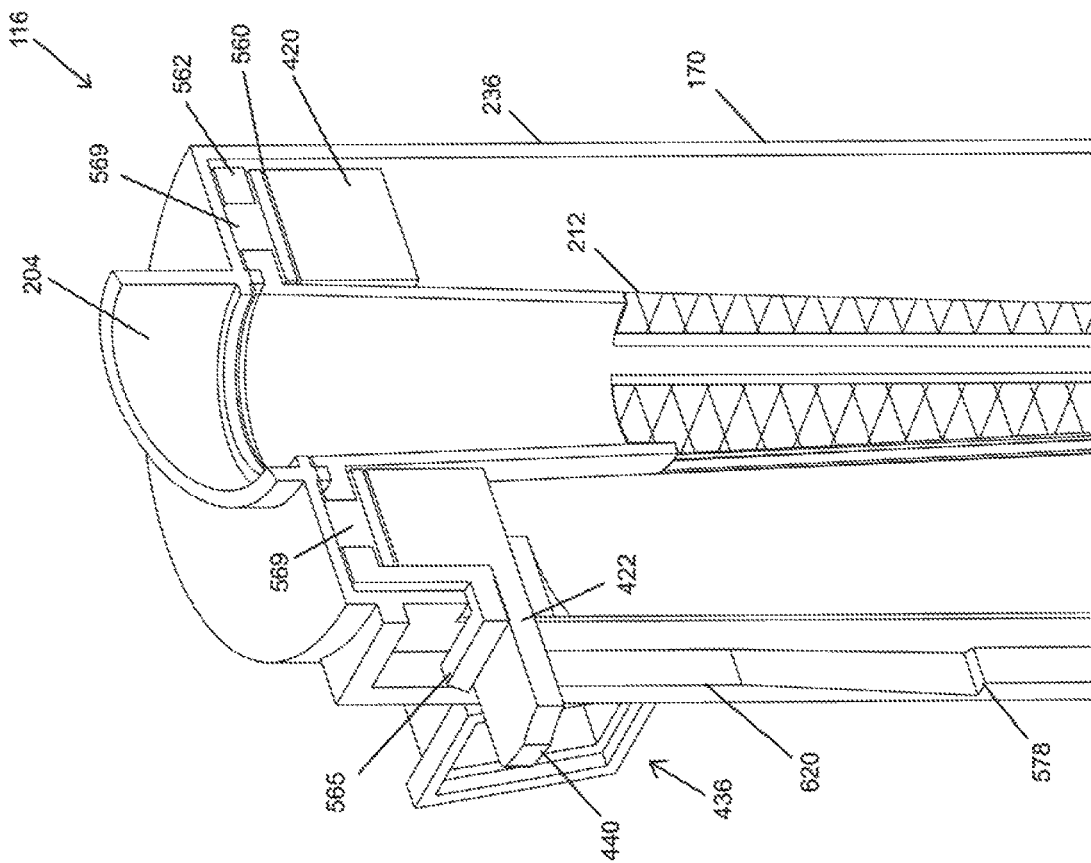

FIG. 128

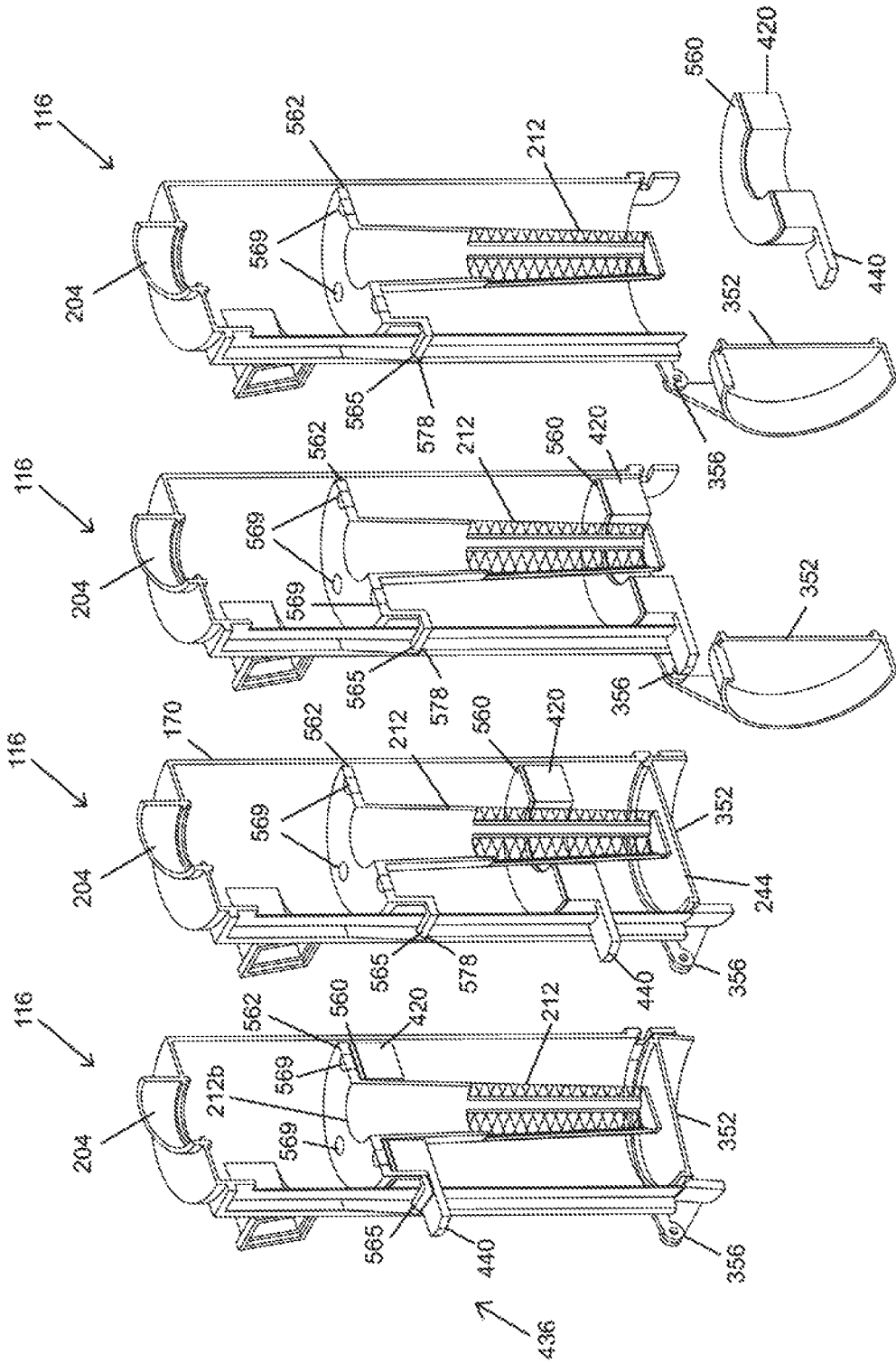

FIG. 129D

FIG. 129C

FIG. 129B

FIG. 129A

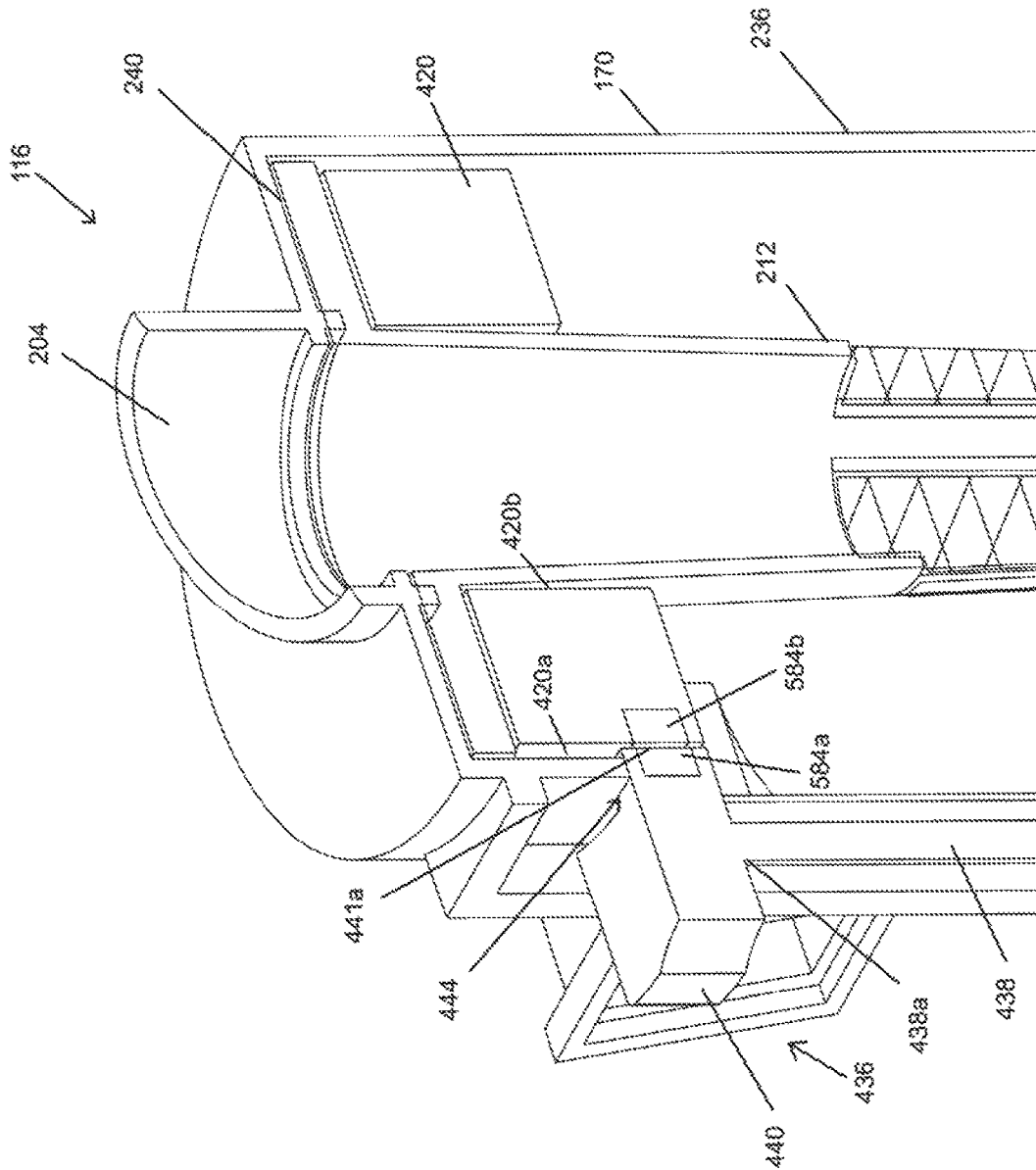

FIG. 130

FIG. 131D

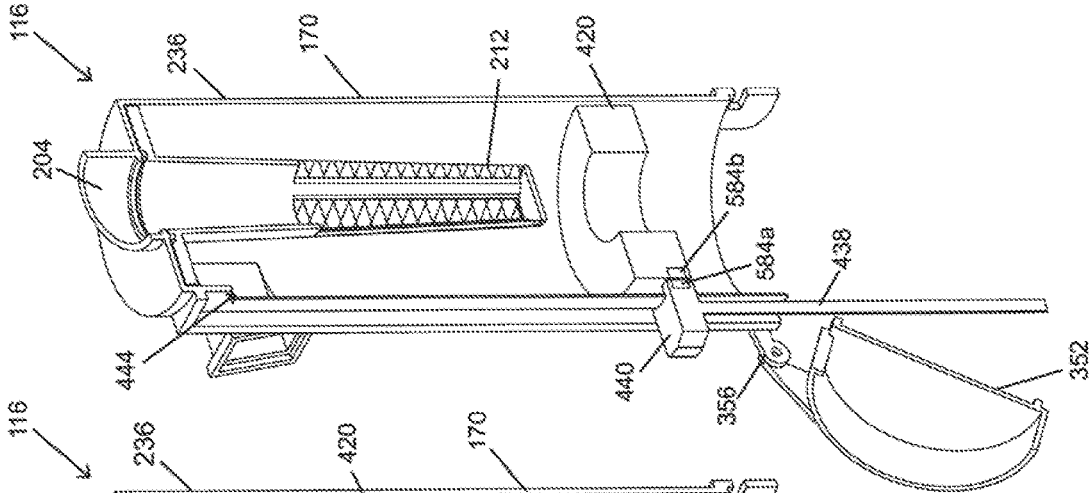

FIG. 131C

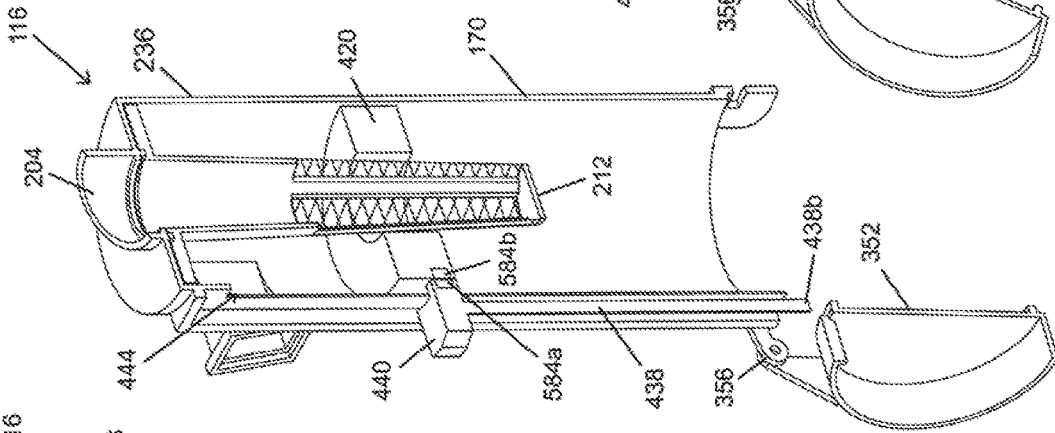

FIG. 131B

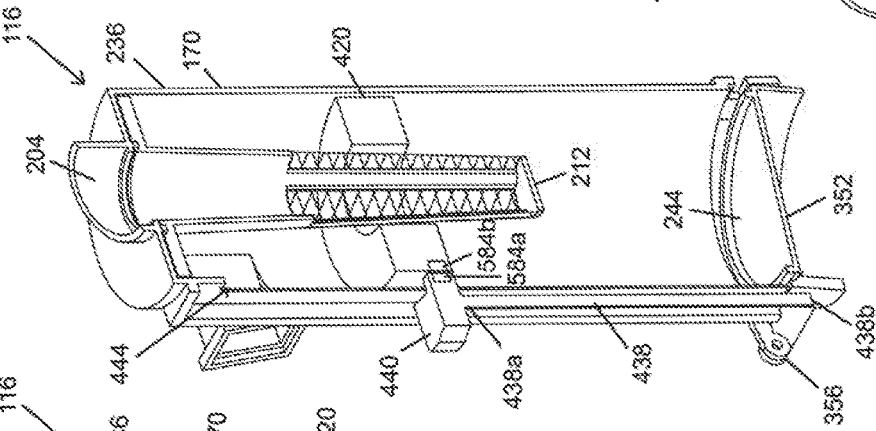
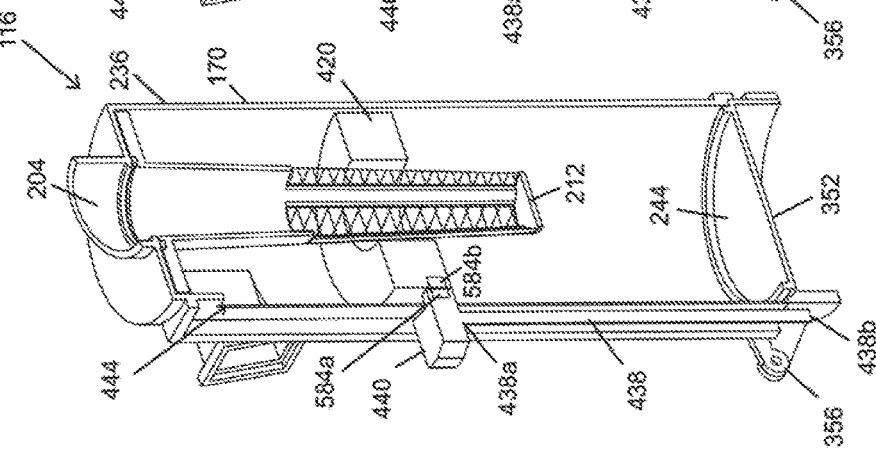

FIG. 131A



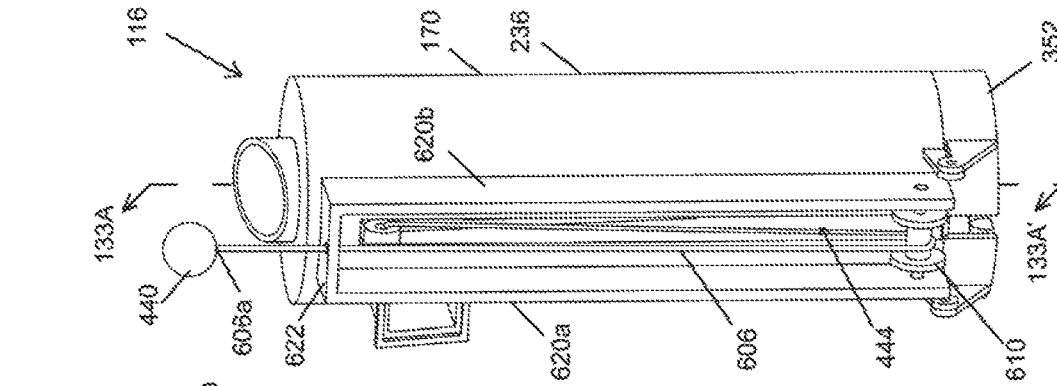

FIG. 132

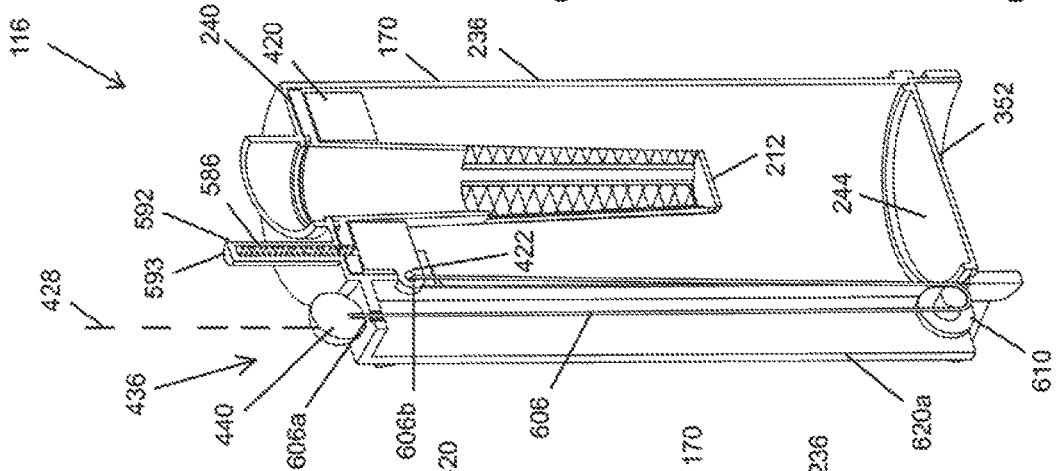

FIG. 133A

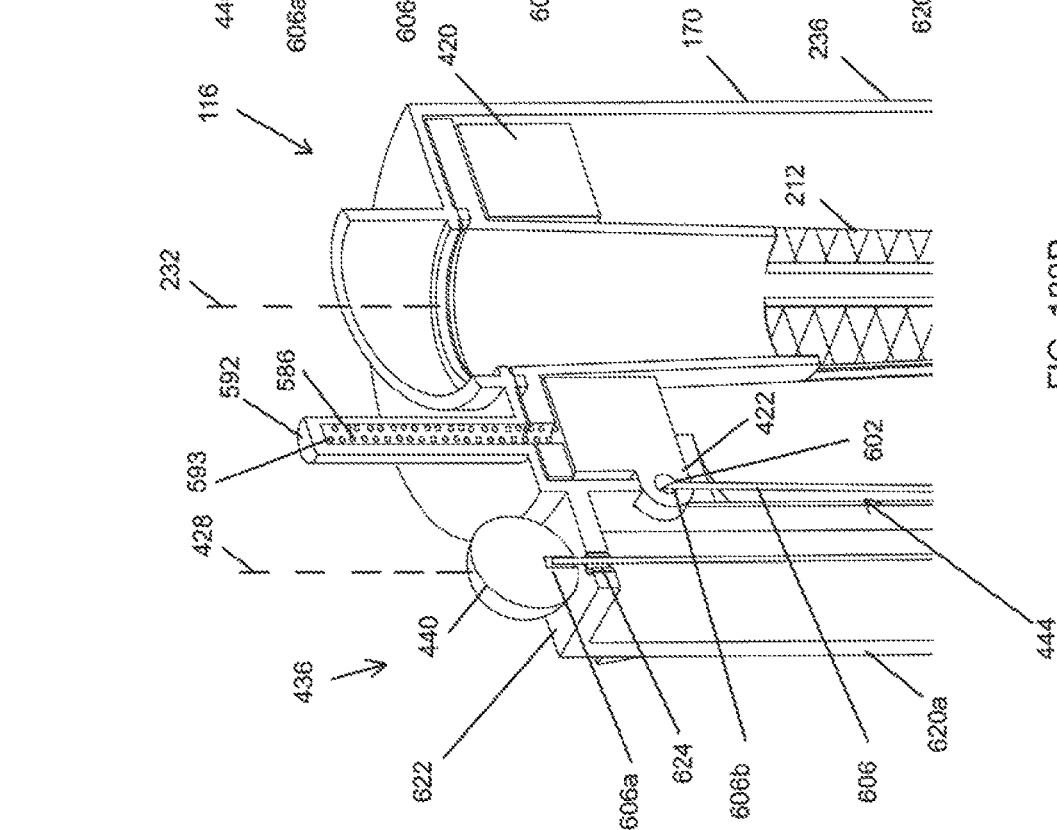

FIG. 133B

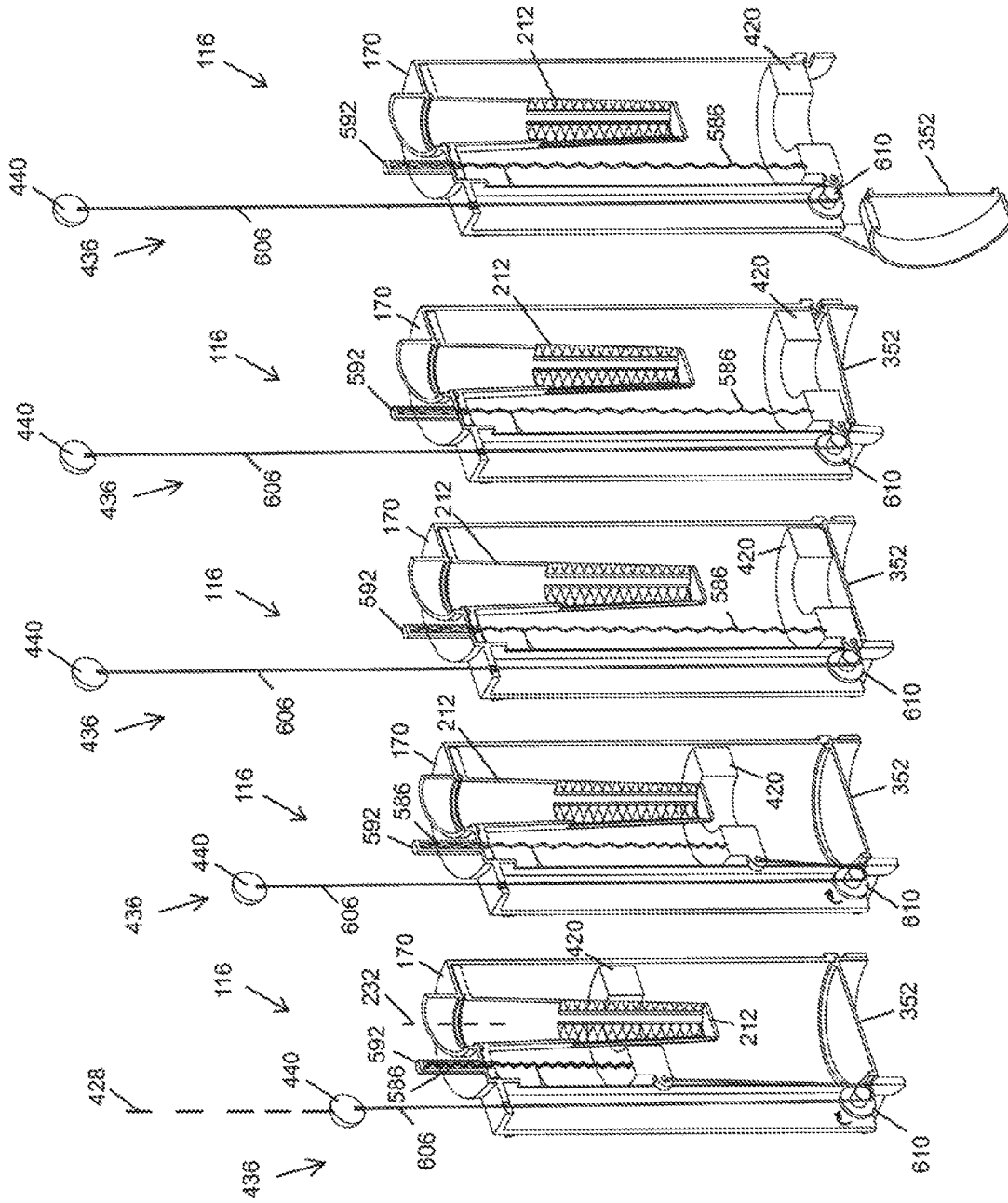

FIG. 134A

FIG. 134B

FIG. 134C

FIG. 134D

FIG. 134E

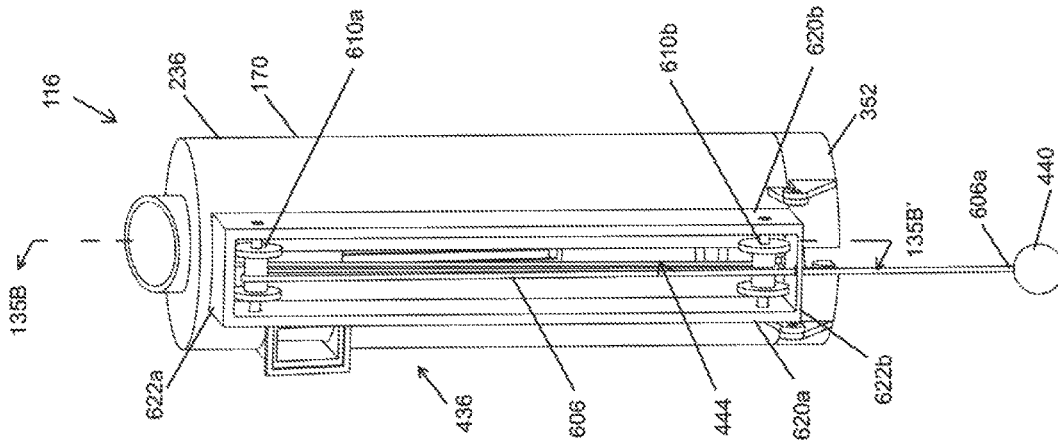

FIG. 135A

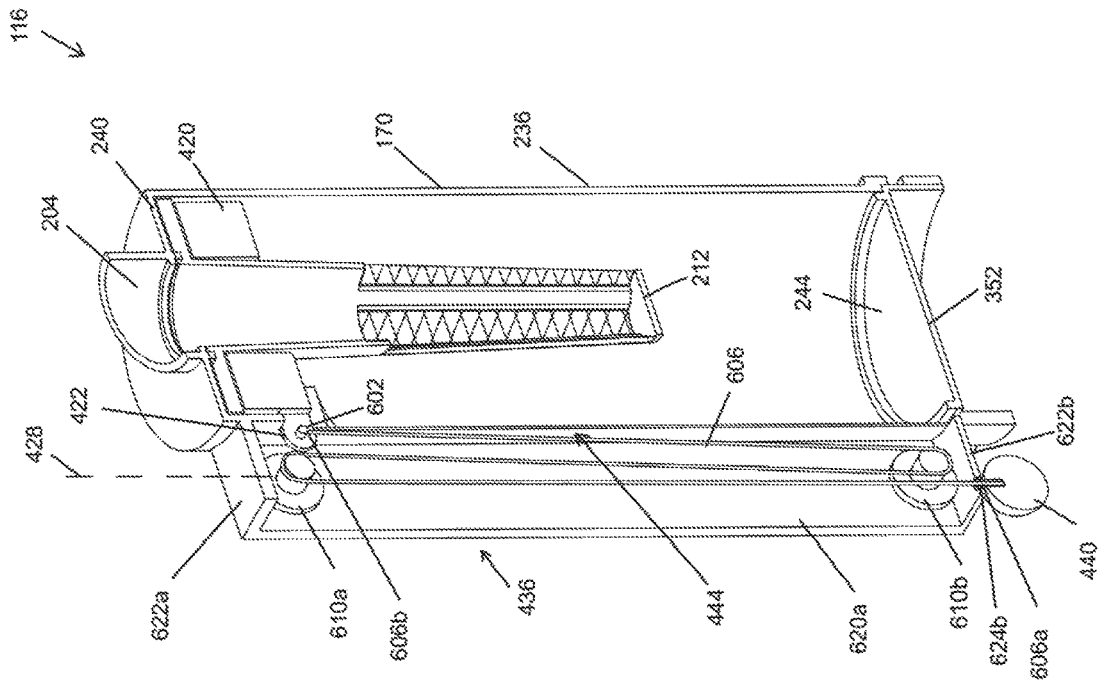
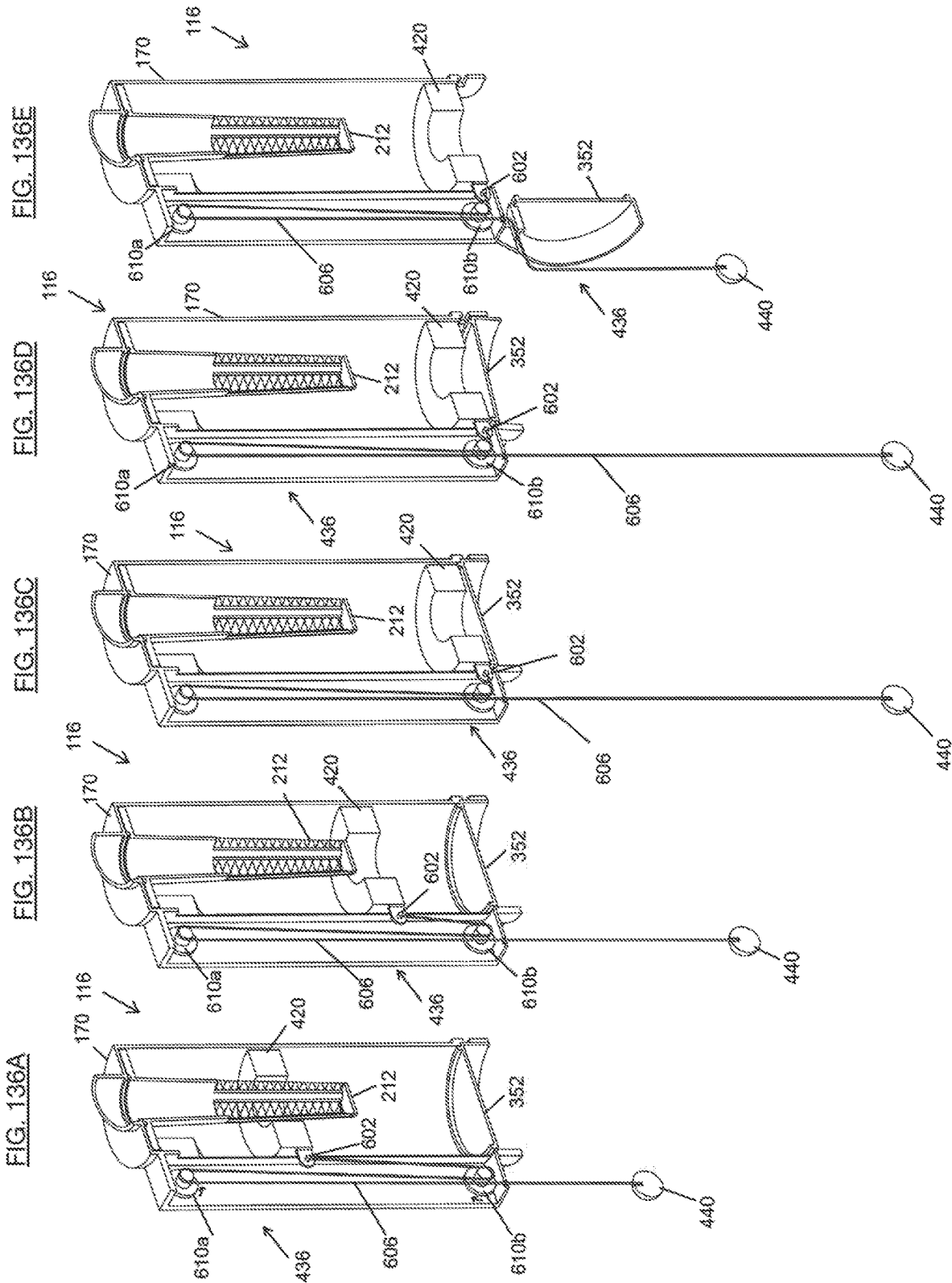

FIG. 135B



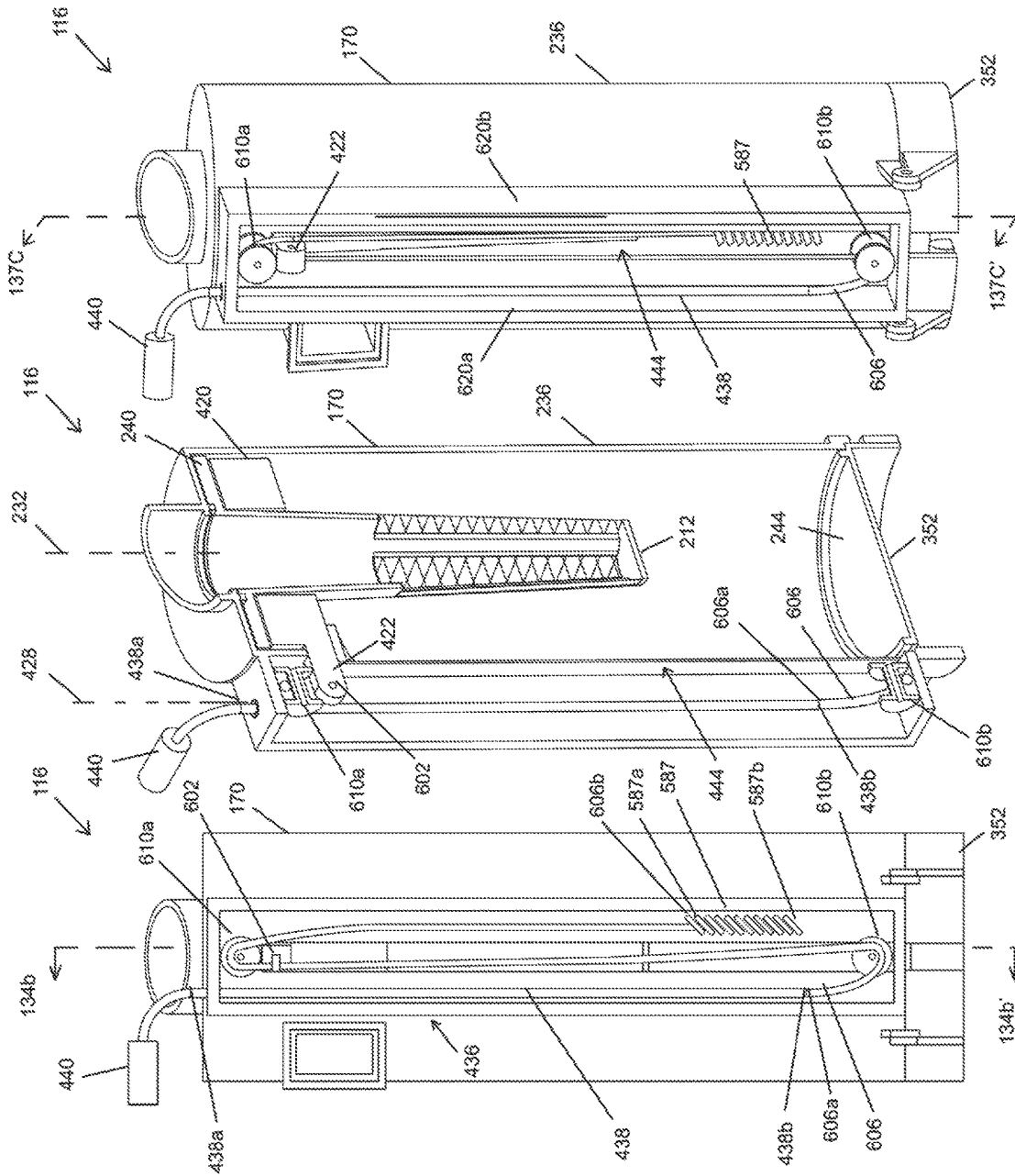

FIG. 137A

FIG. 137C

FIG. 137B

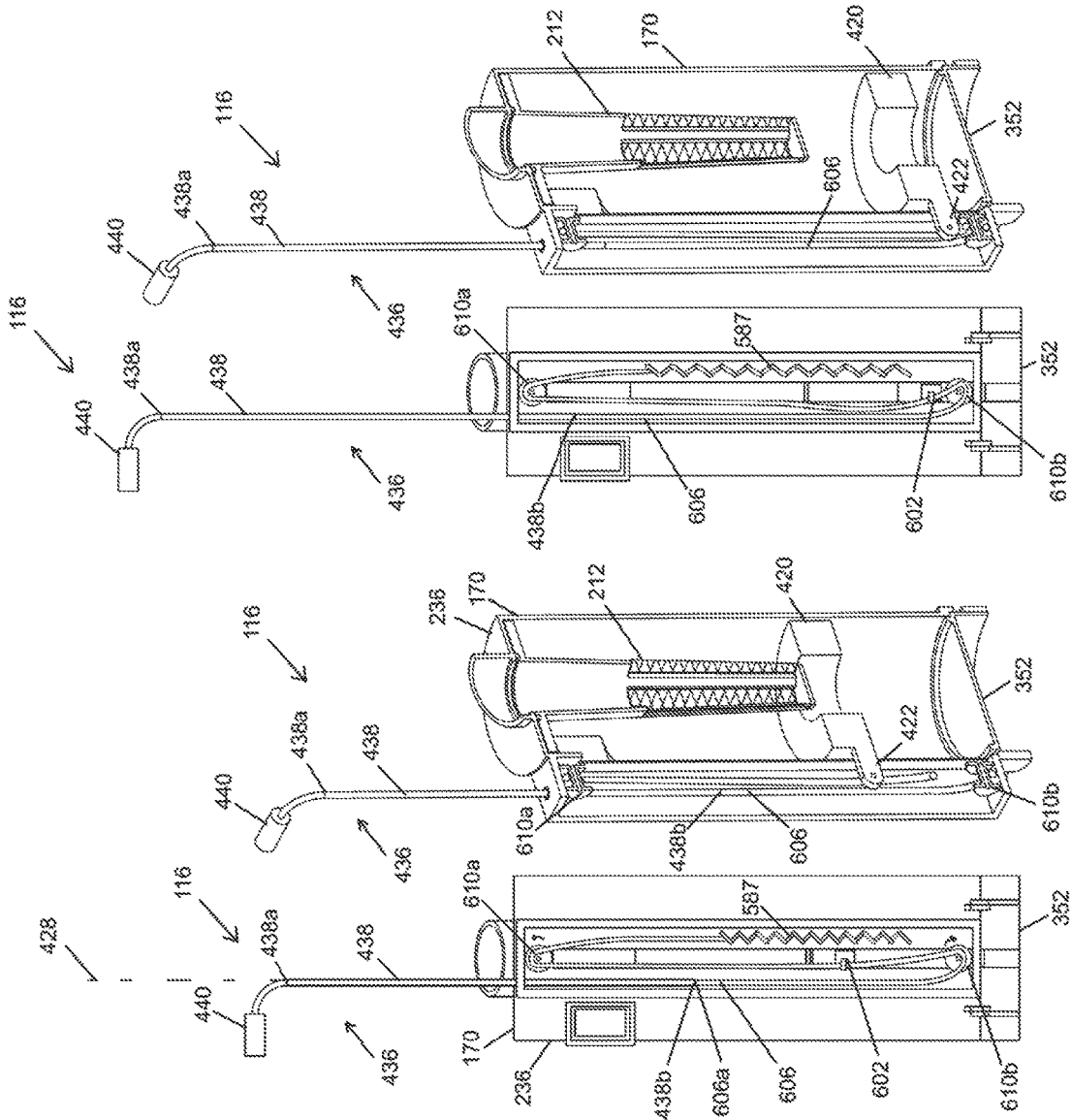
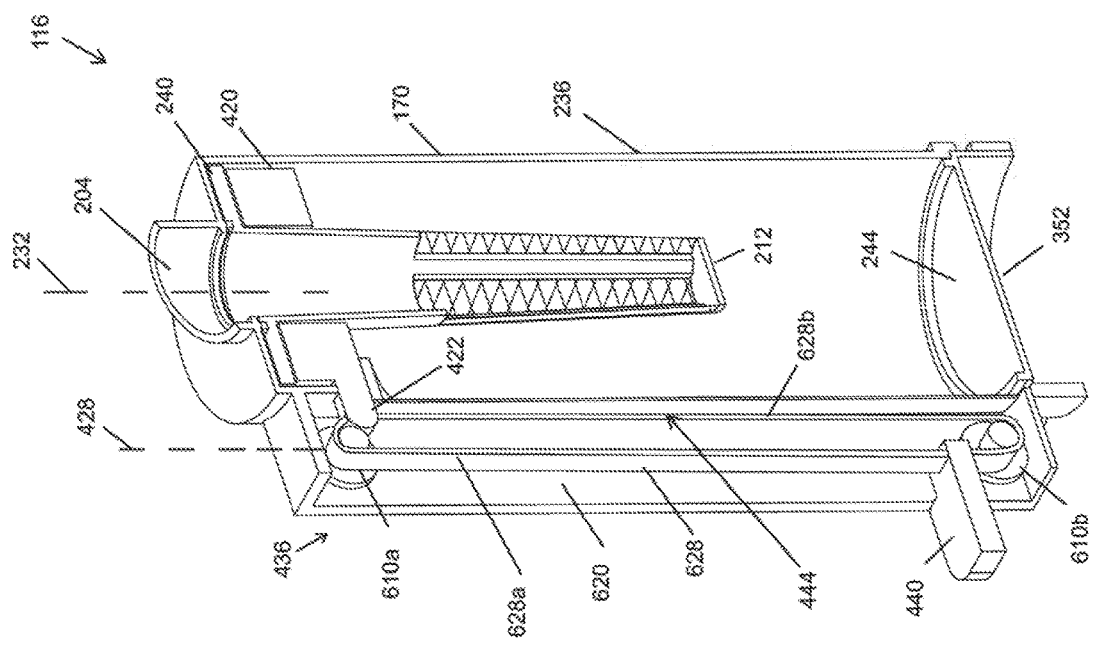
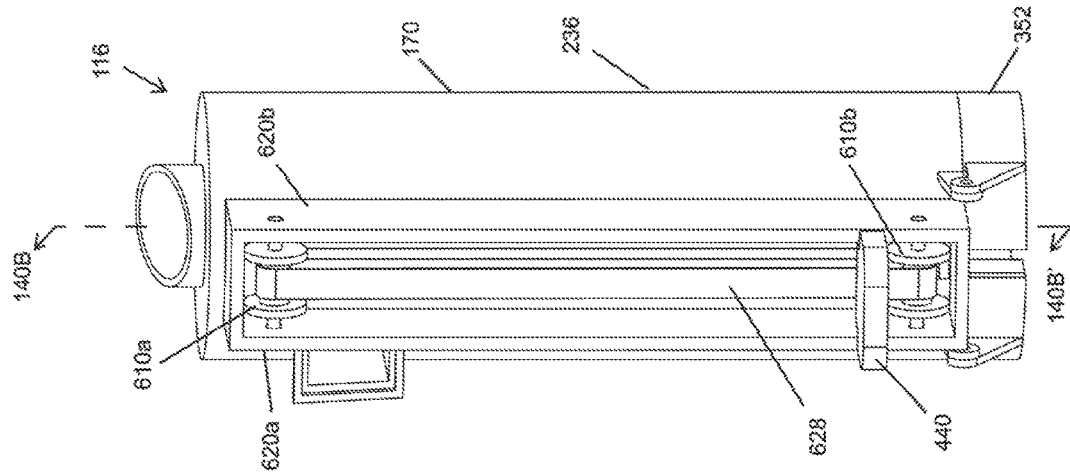

FIG. 139B

FIG. 139A

FIG. 138B

FIG. 138A



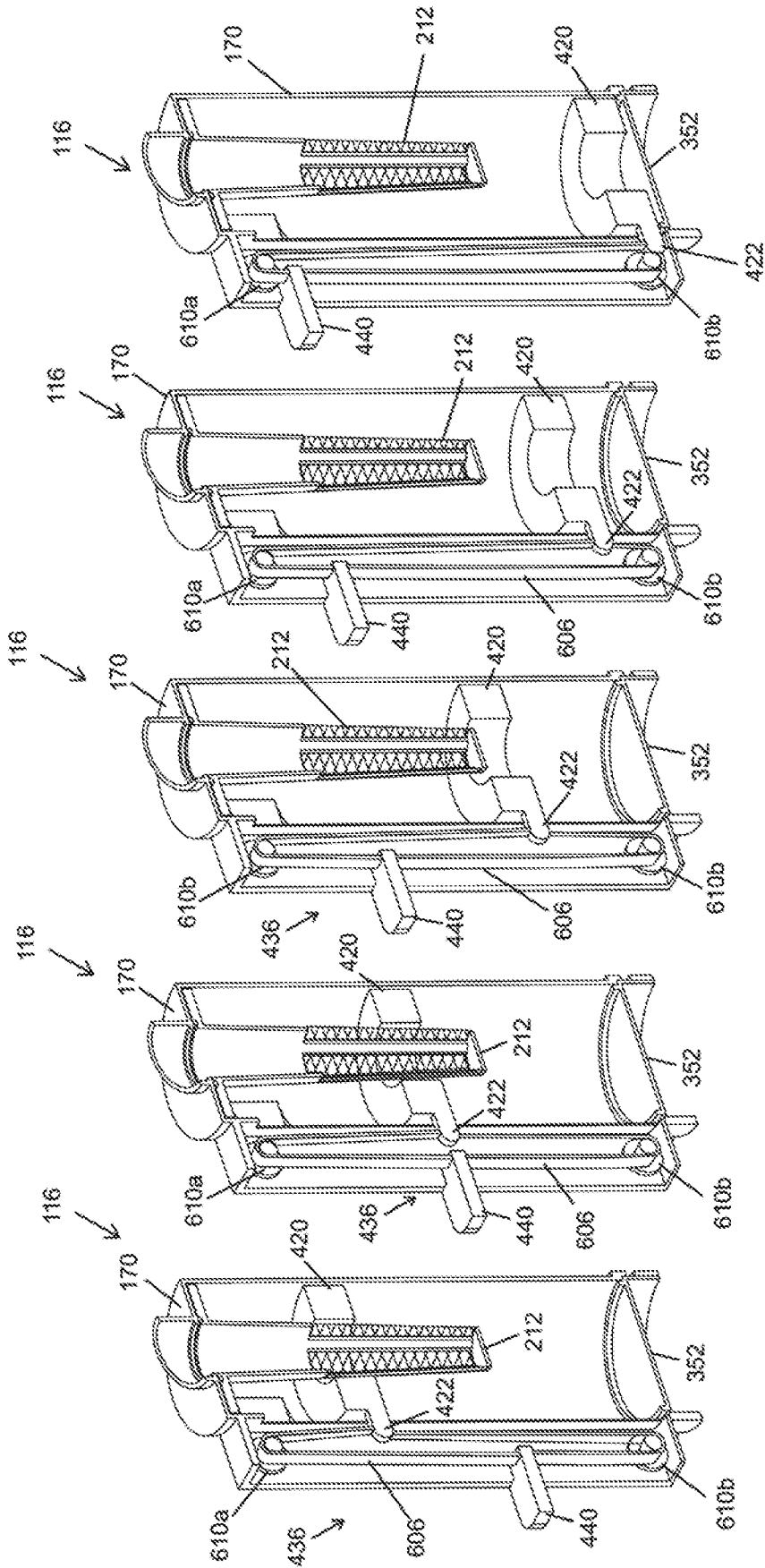

FIG. 141E

FIG. 141D

FIG. 141C

FIG. 141B

FIG. 141A

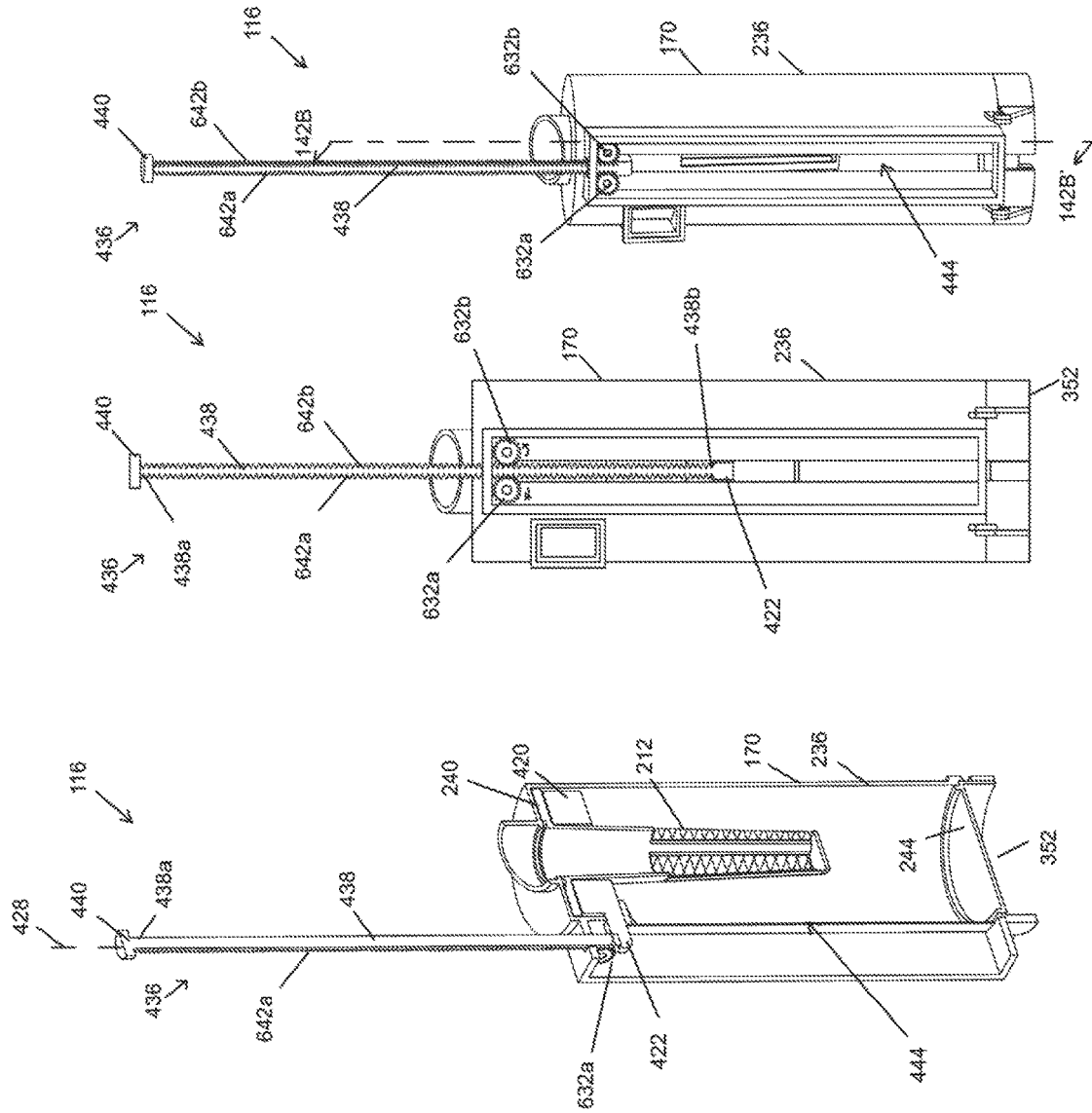

FIG. 142A

FIG. 142B

FIG. 142C

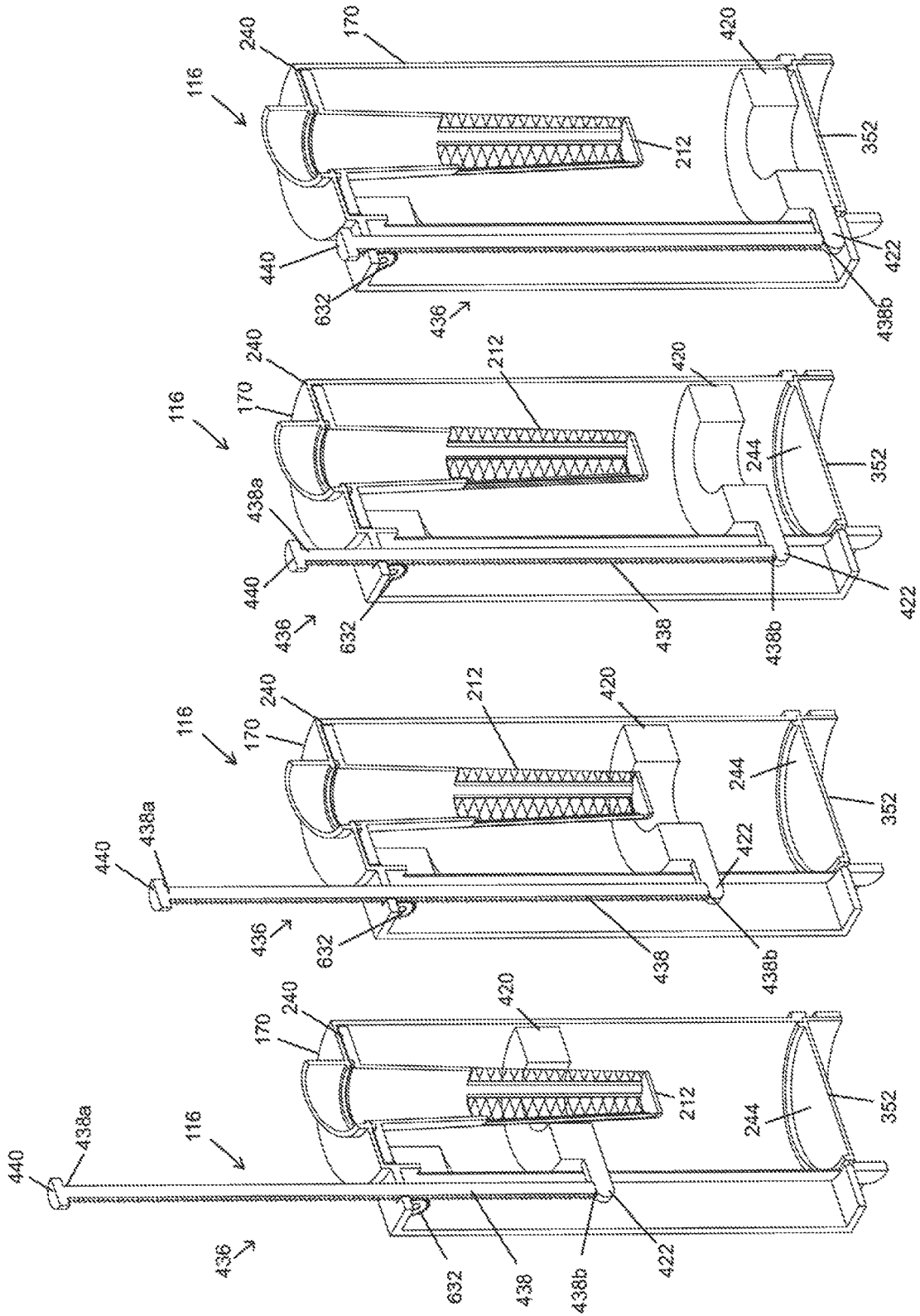

FIG. 143D

FIG. 143C

FIG. 143B

FIG. 143A

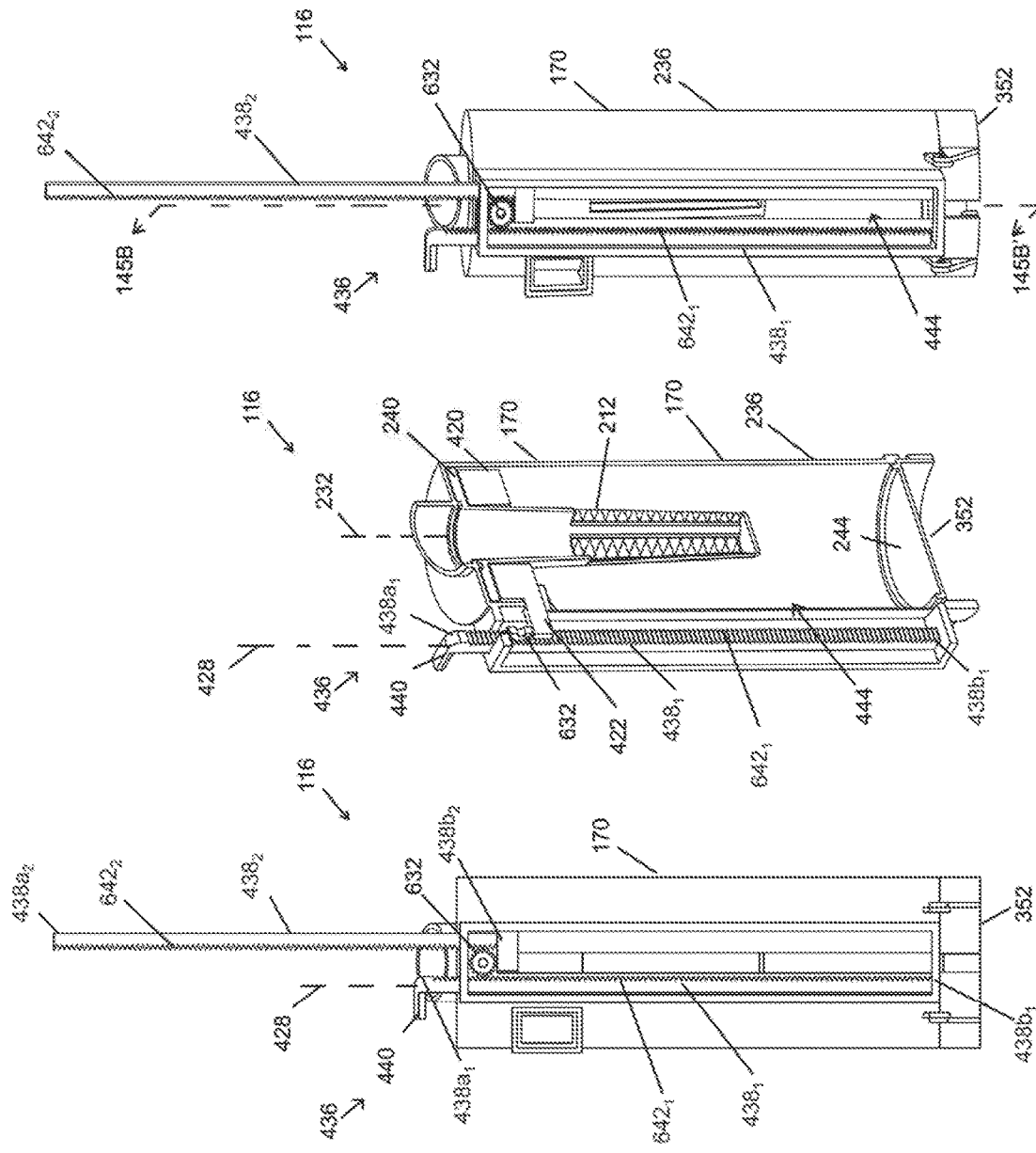
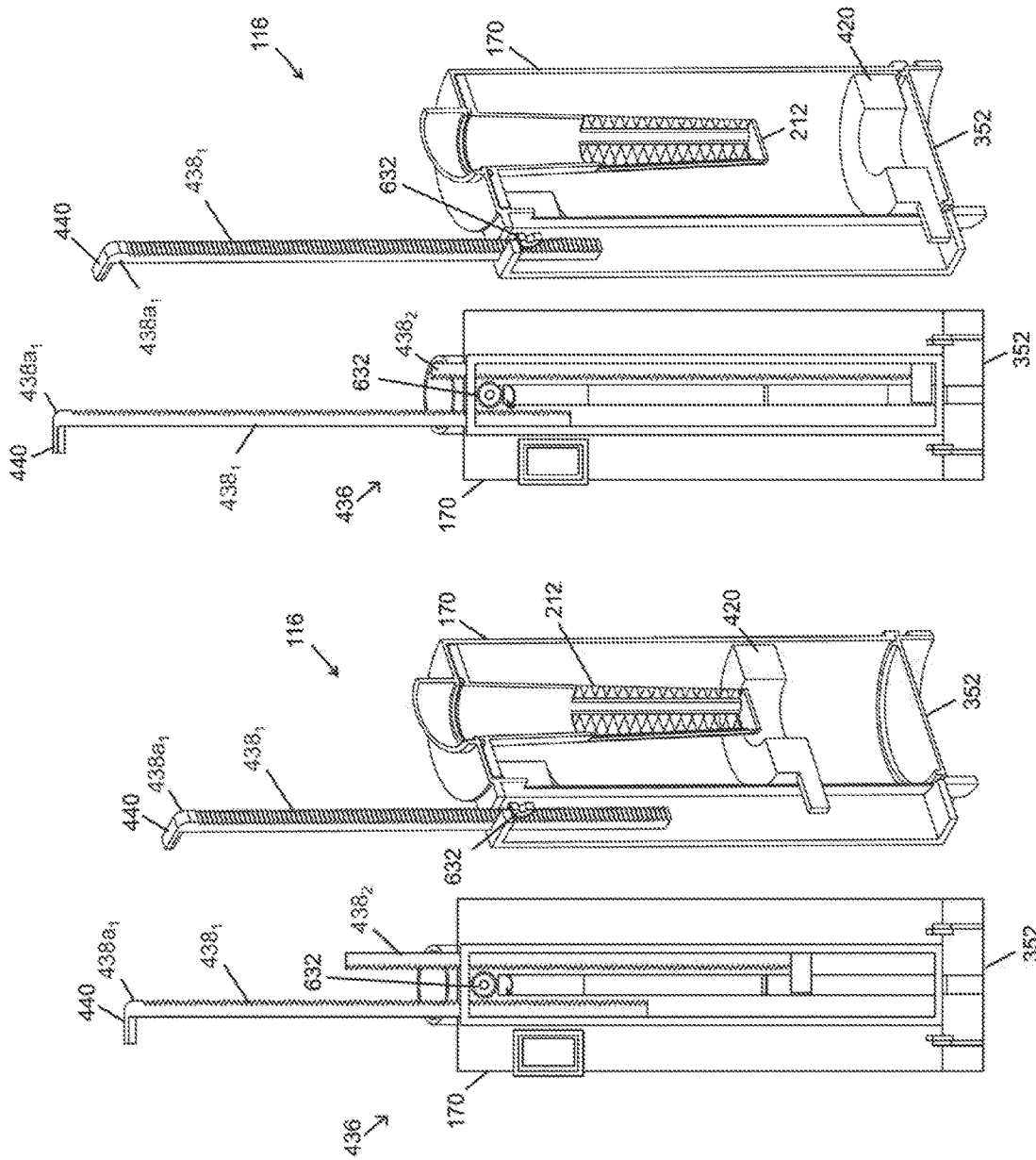

FIG. 144

FIG. 145B

FIG. 145A



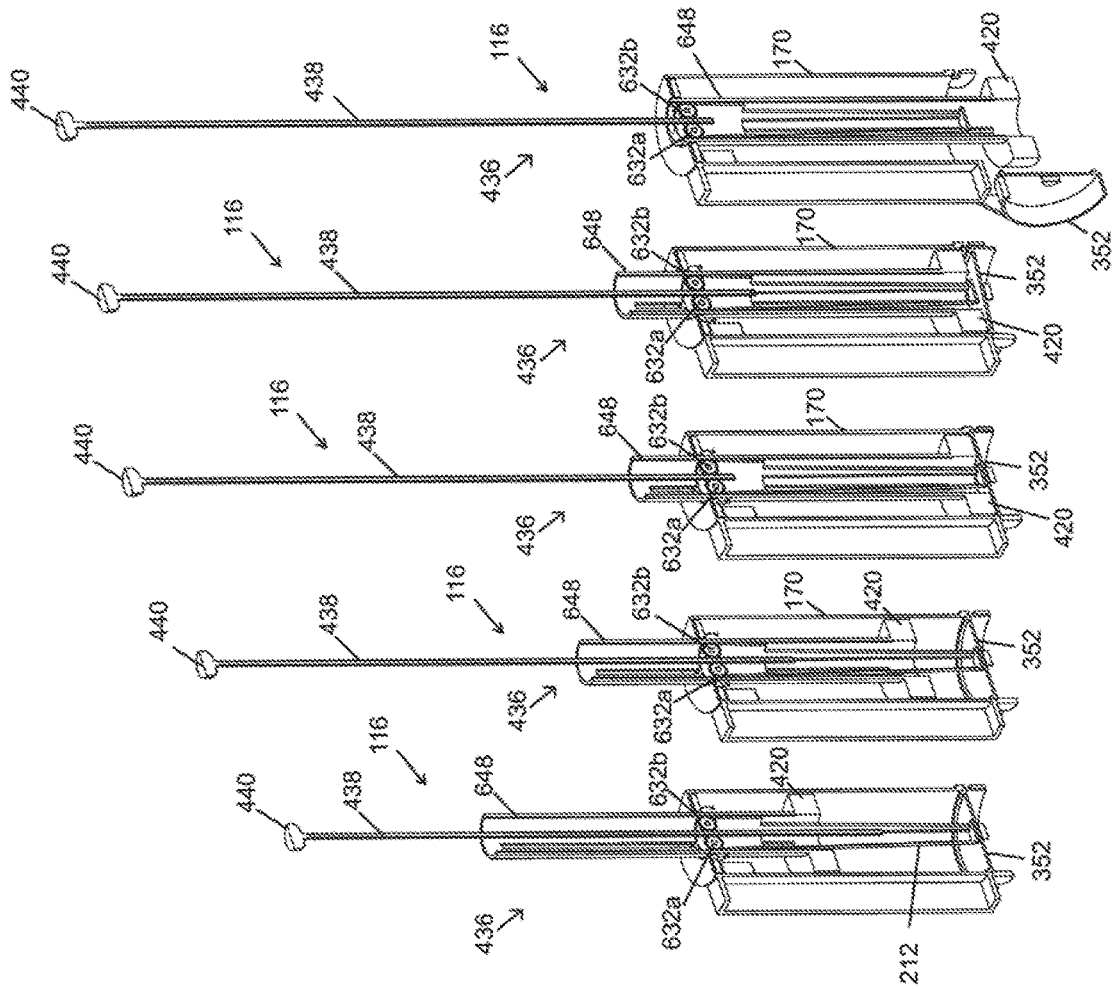

FIG. 149A FIG. 149B FIG. 149C FIG. 149D FIG. 149E

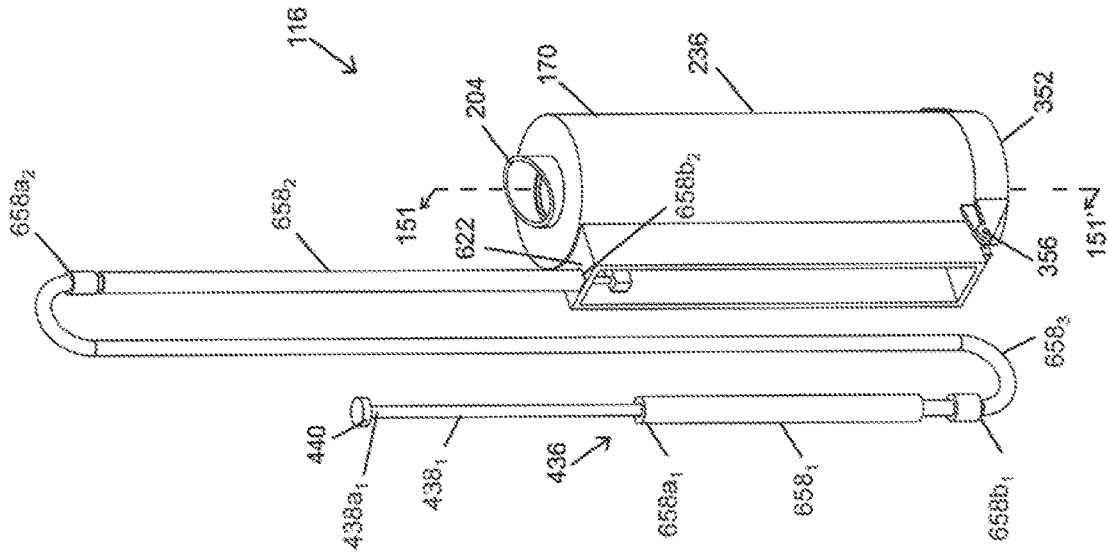

FIG. 150

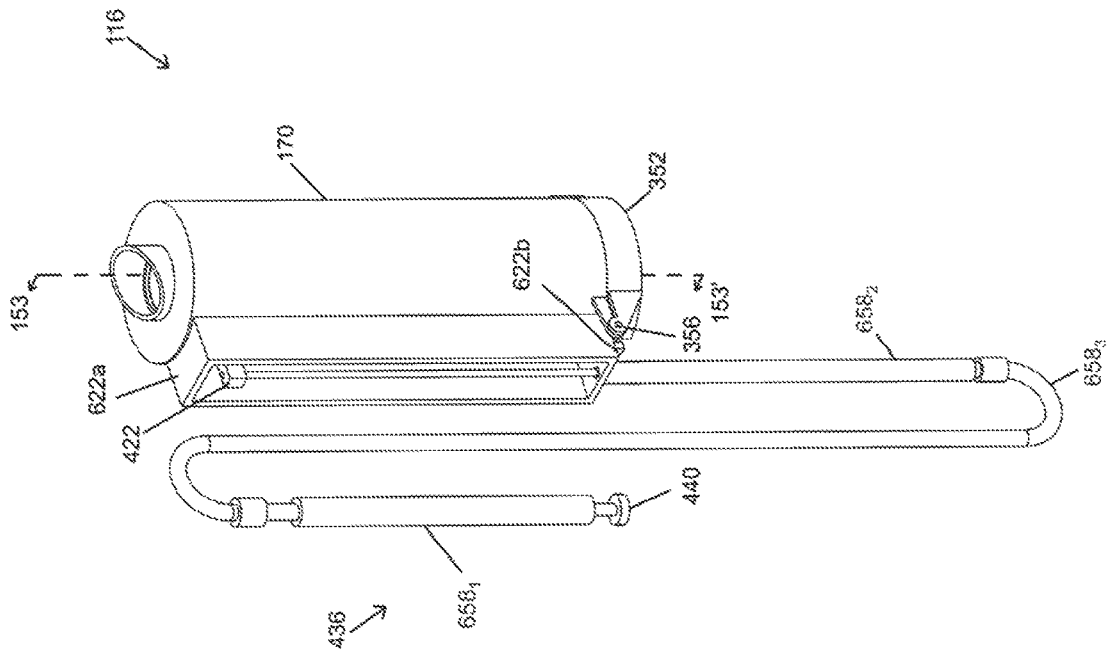

FIG. 152

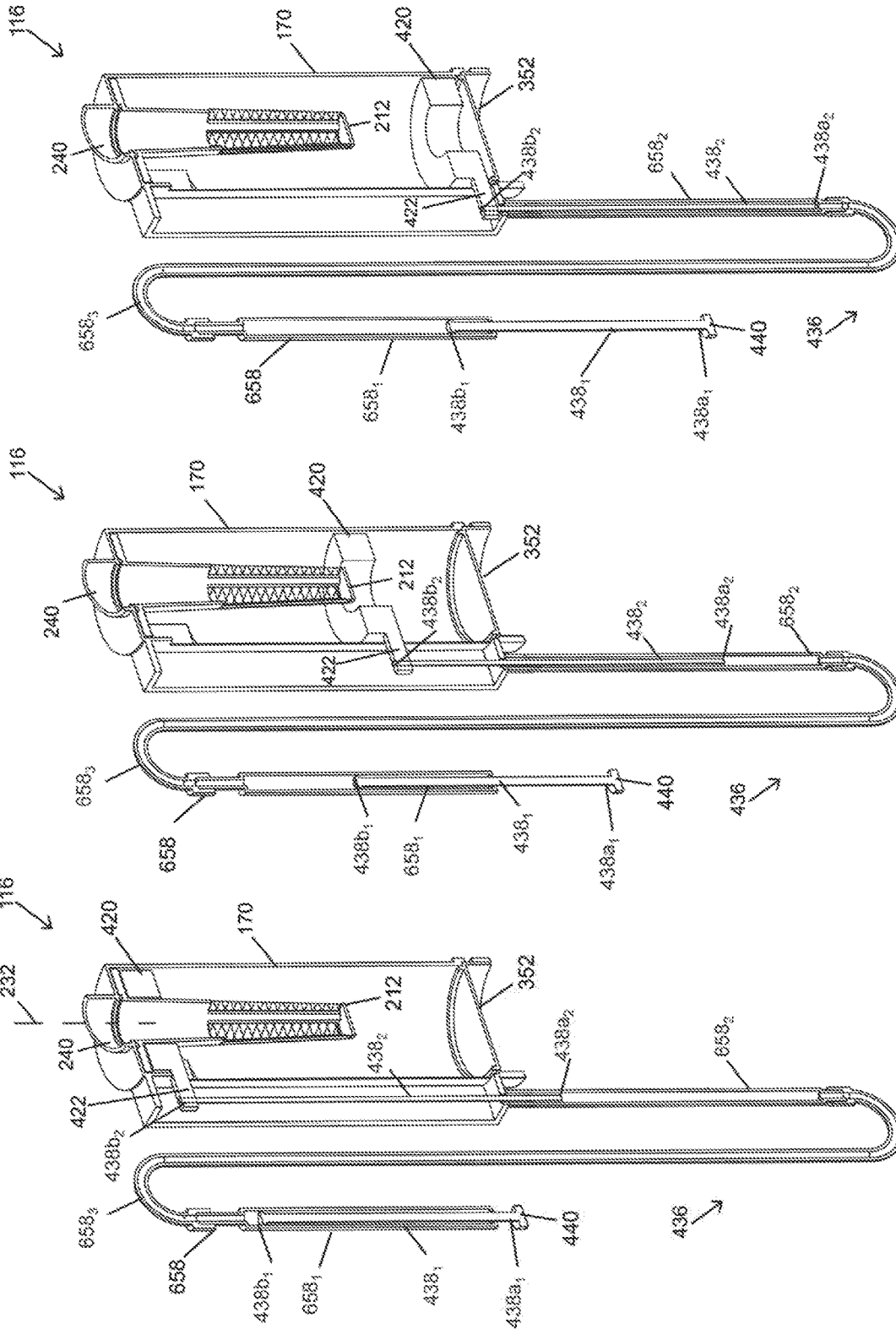

FIG. 153C

FIG. 153B

FIG. 153A

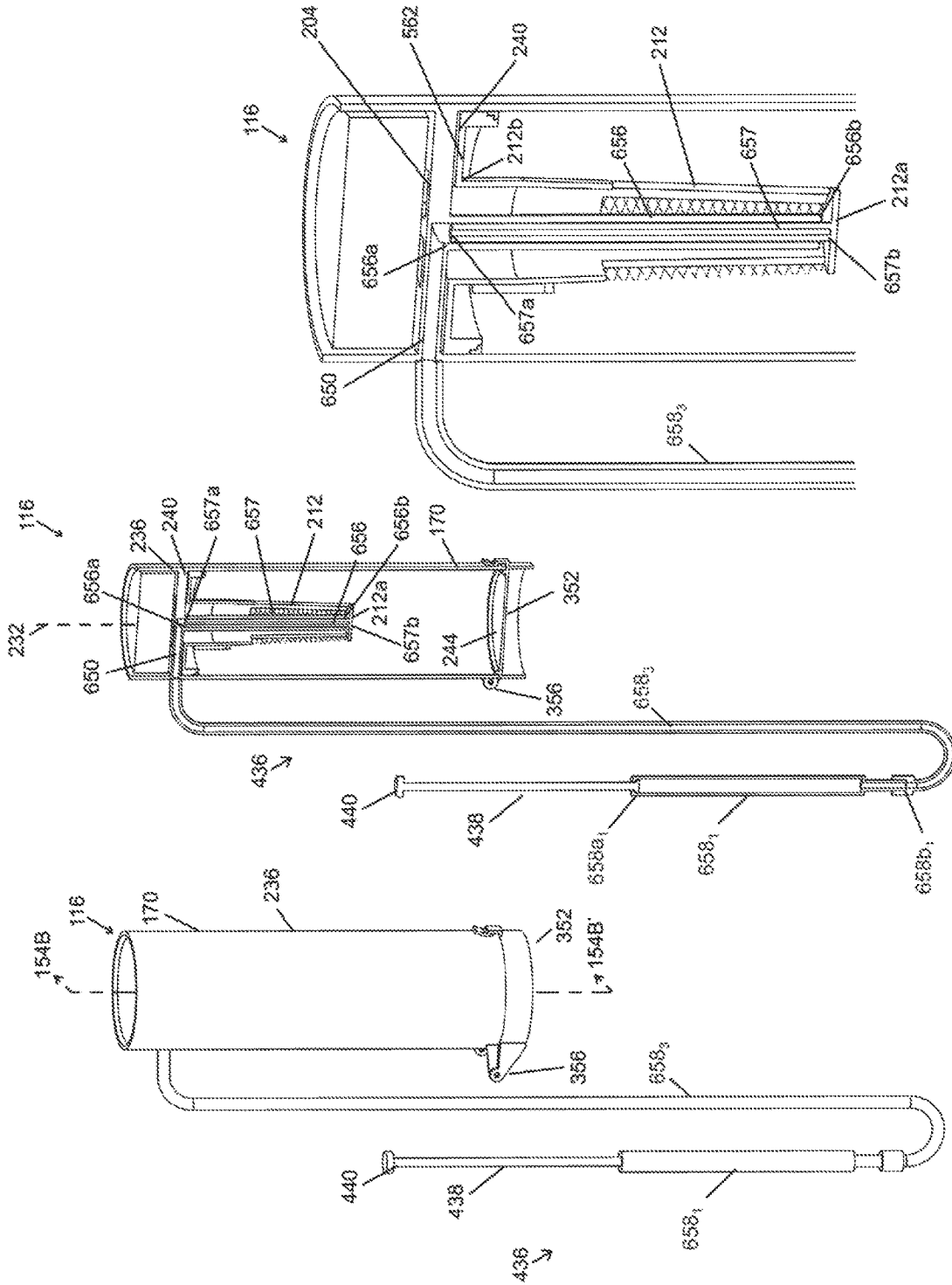

FIG. 154C

FIG. 154B

FIG. 154A

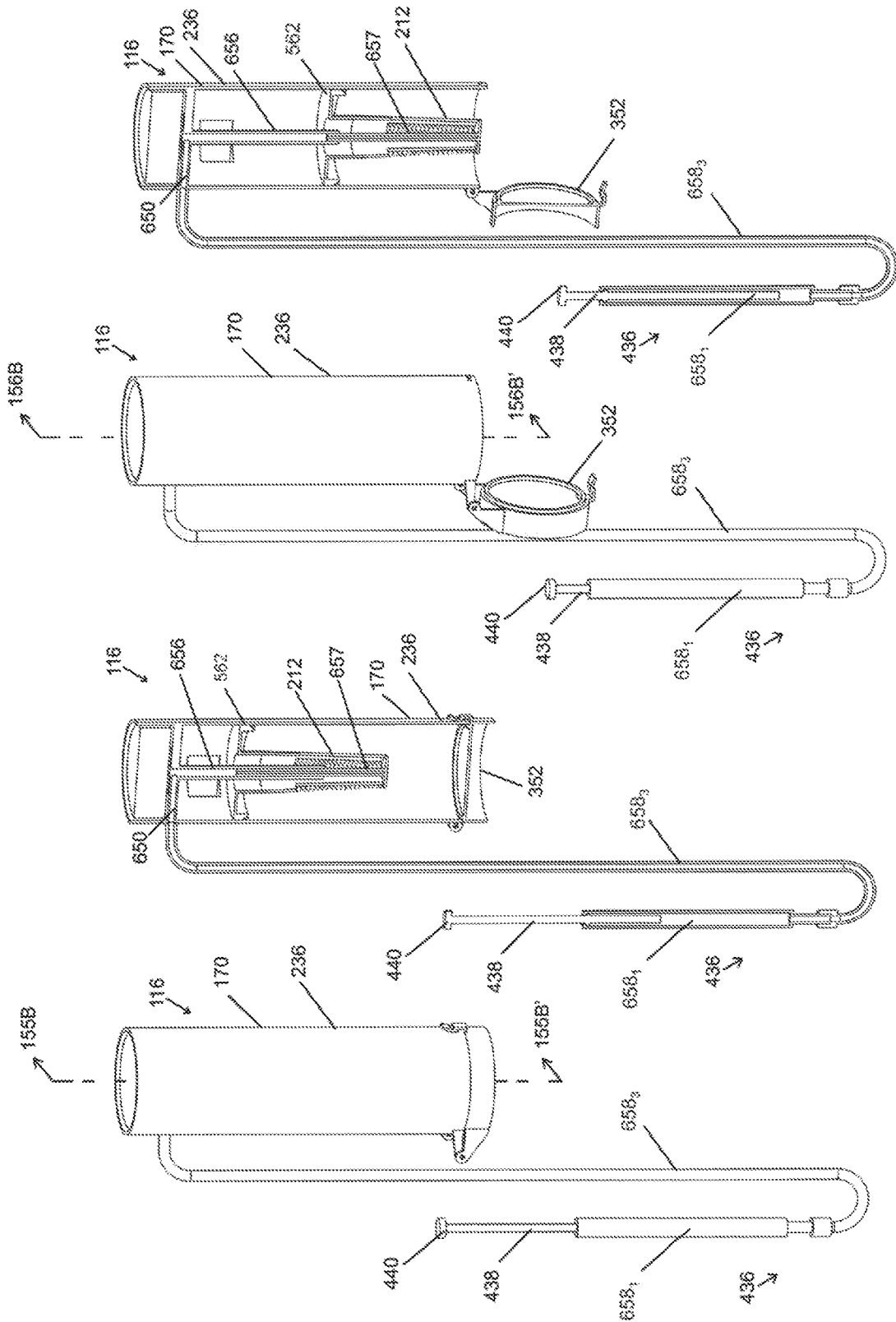

FIG. 155A

FIG. 155B

FIG. 156A

FIG. 156B

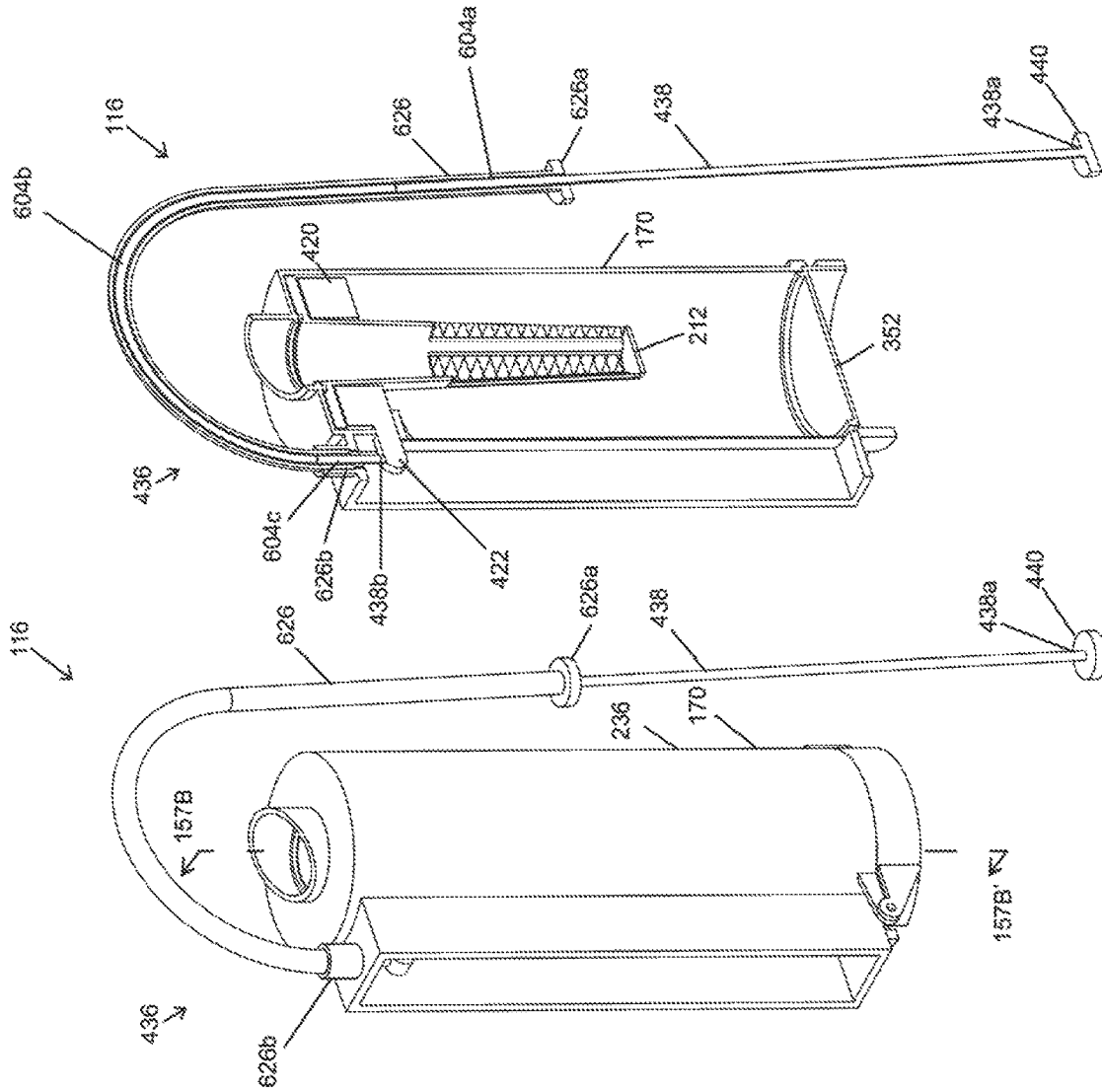

FIG. 157B

FIG. 157A

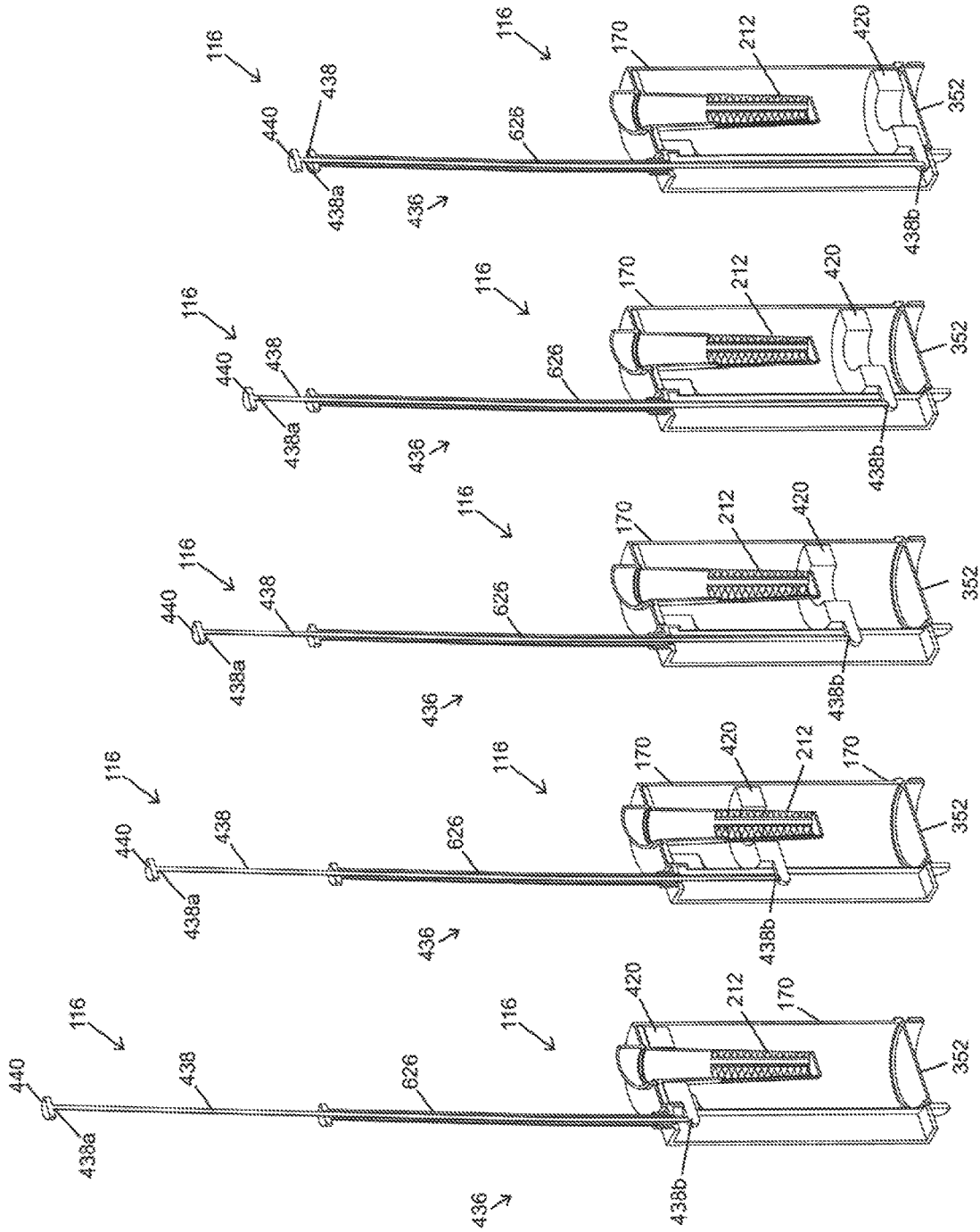

FIG. 158A

FIG. 158B

FIG. 158C

FIG. 158D

FIG. 158E

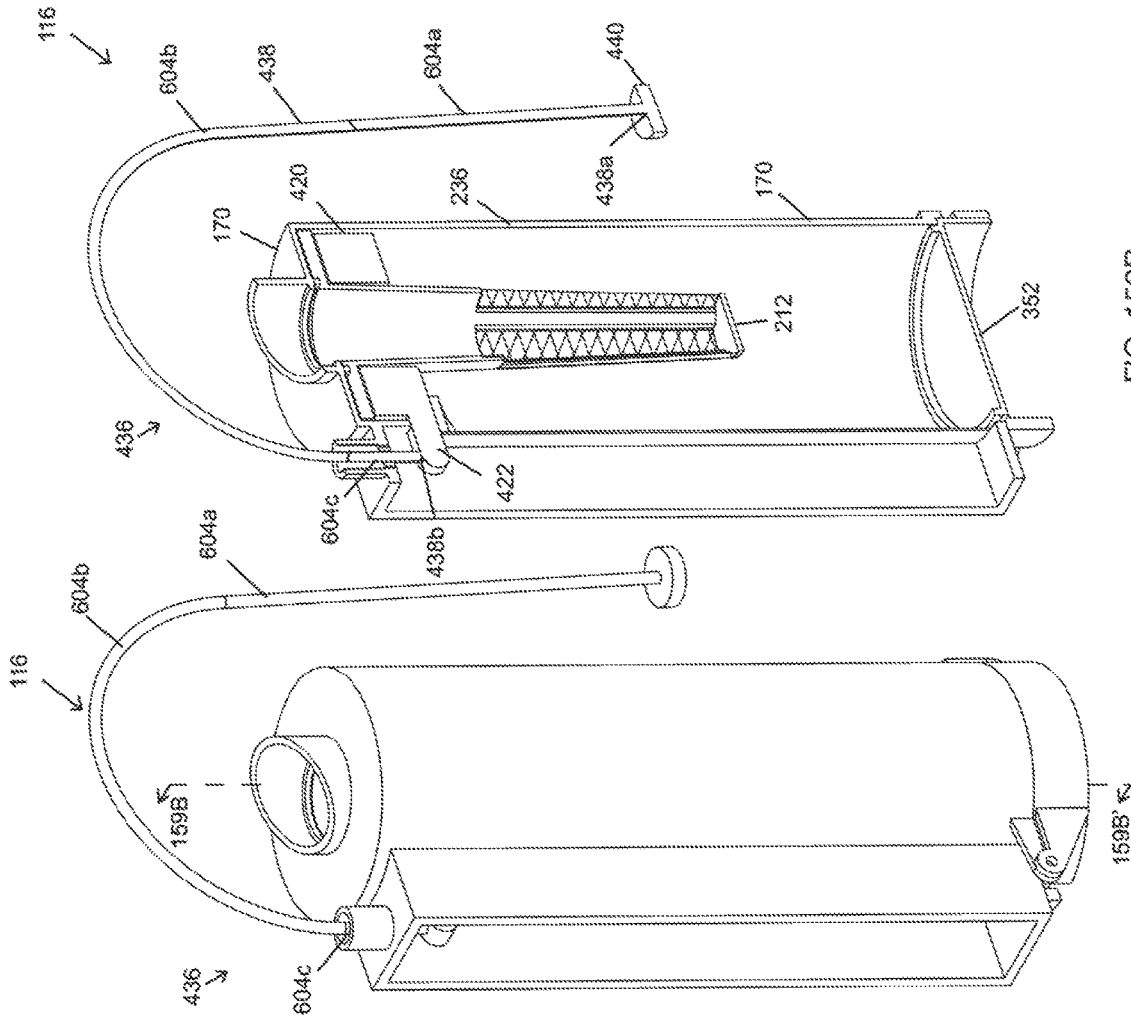

FIG. 159B

FIG. 159A

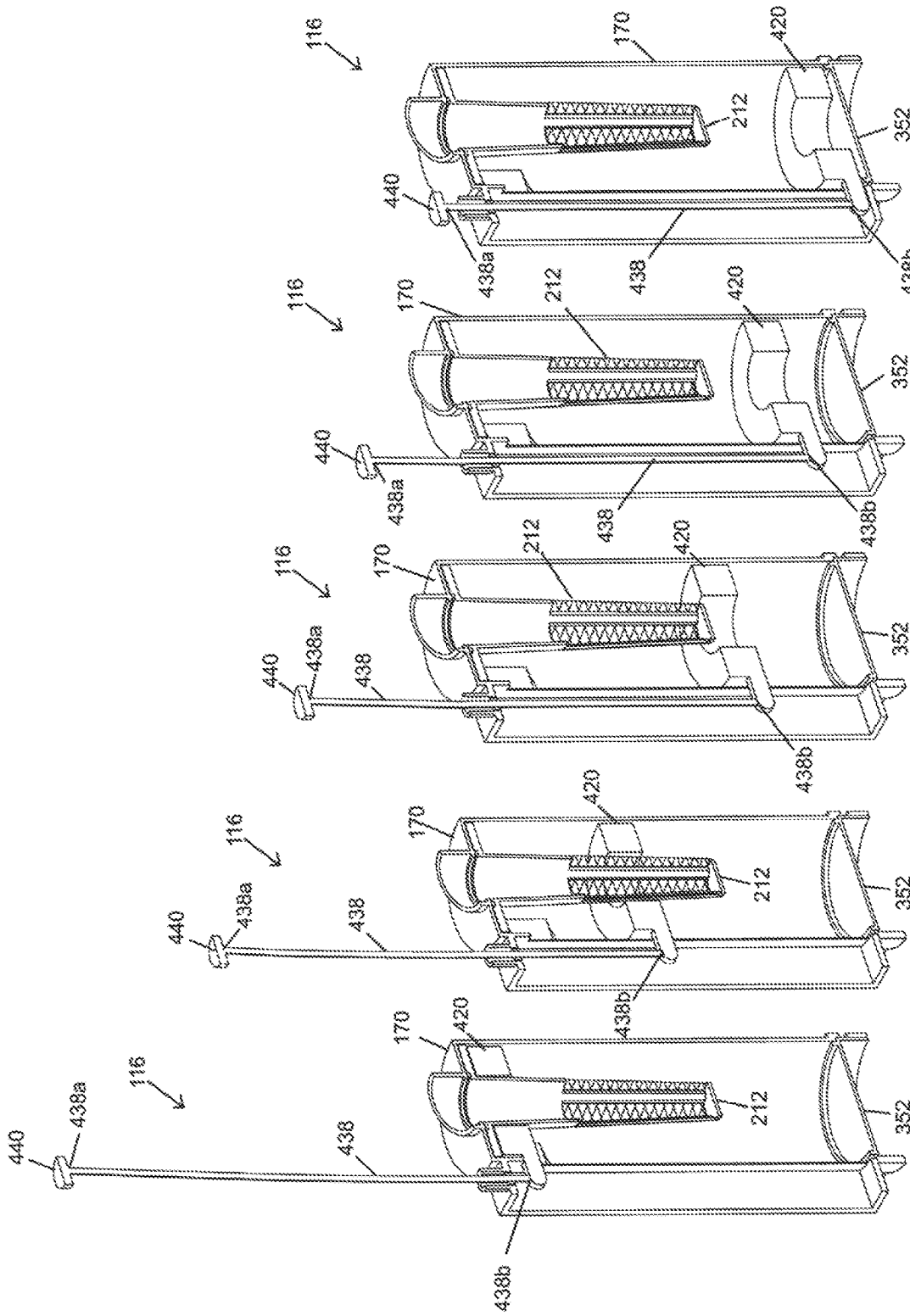

FIG. 160E

FIG. 160D

FIG. 160C

FIG. 160B

FIG. 160A

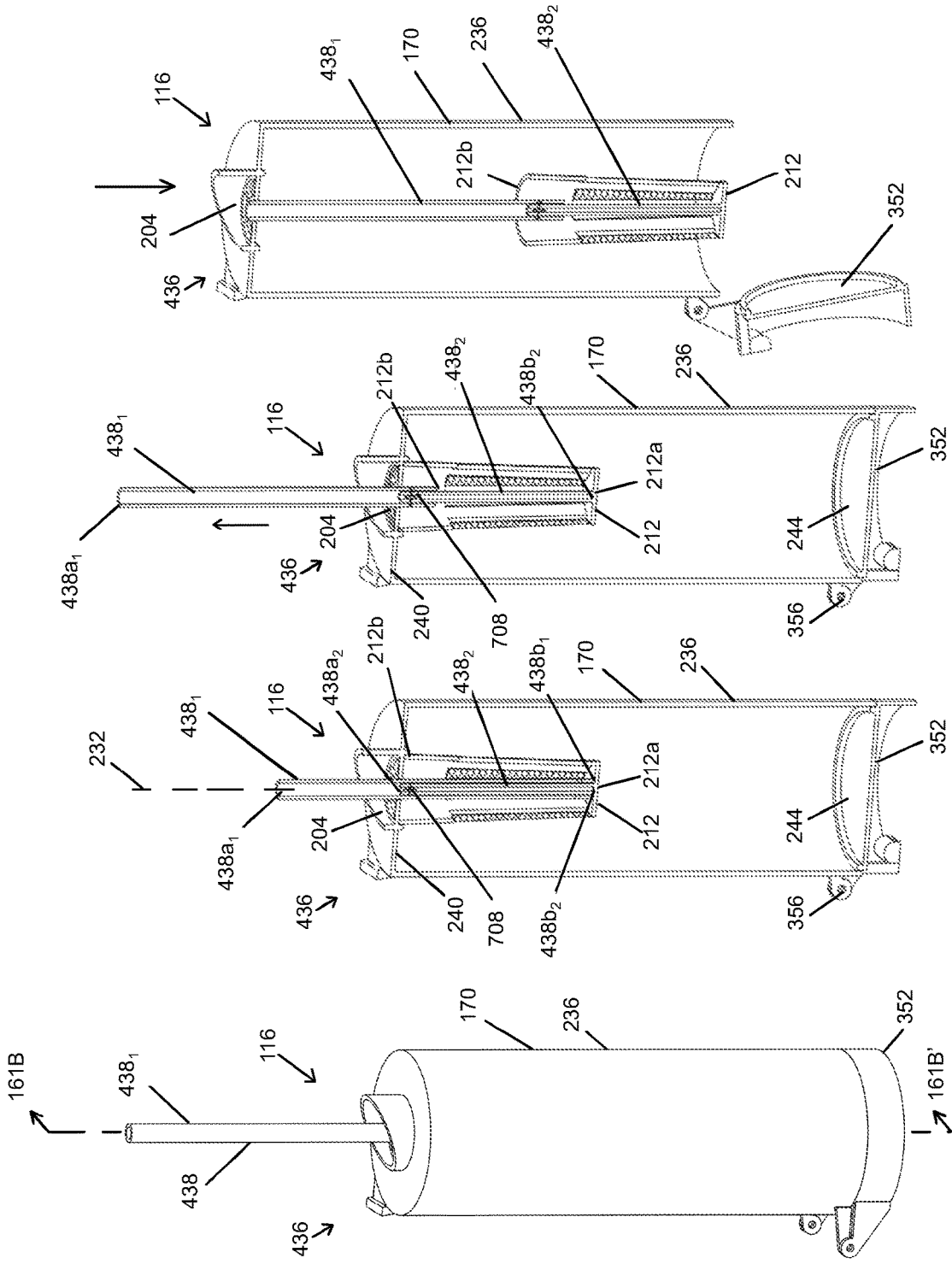

FIG. 161D

FIG. 161C

FIG. 161B

FIG. 161A

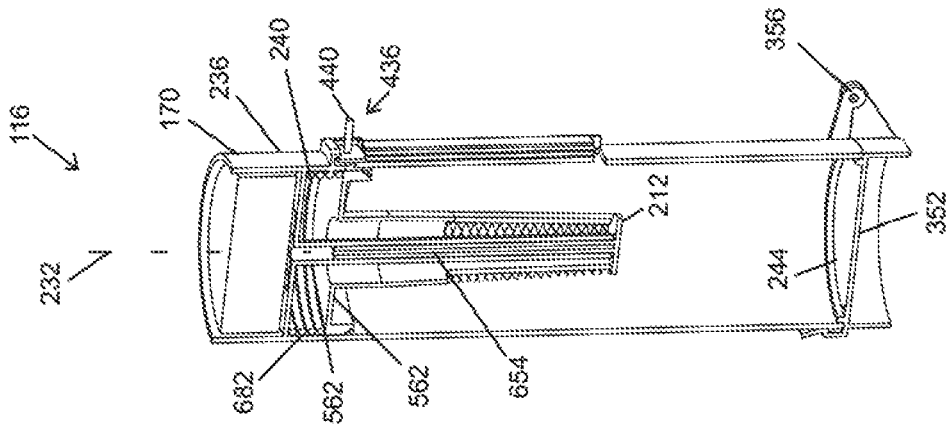

FIG. 162B

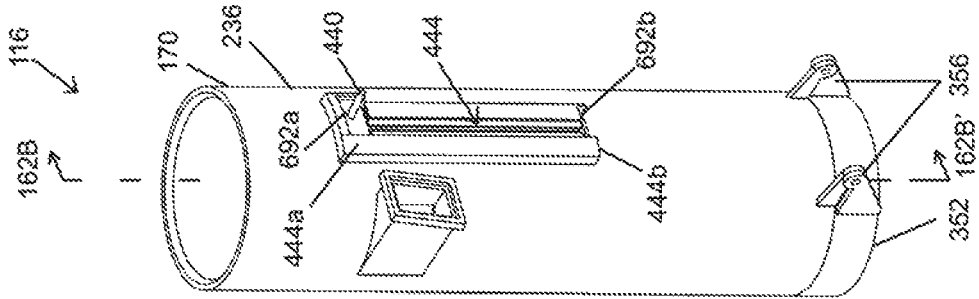

FIG. 162A

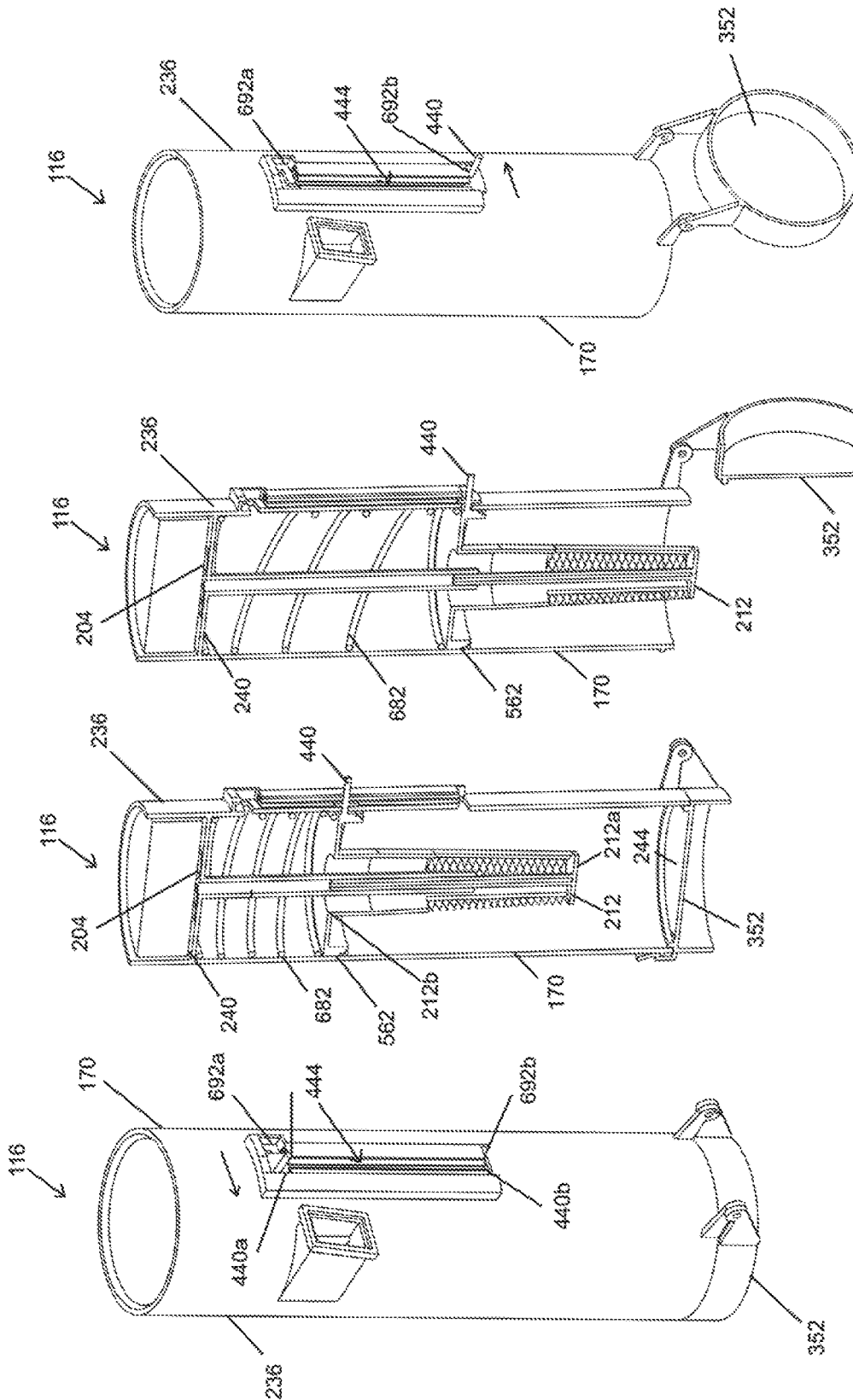

FIG. 163A

FIG. 163B

FIG. 163C

FIG. 163D

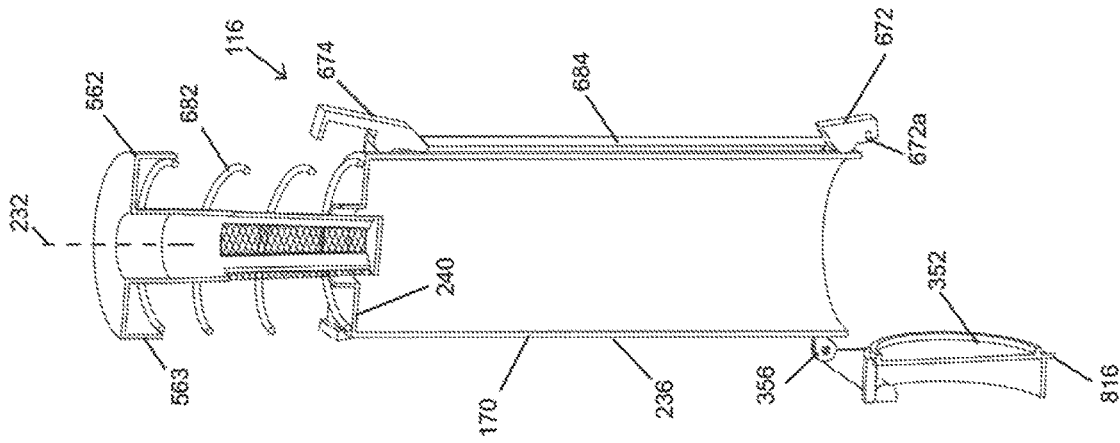

FIG. 164C

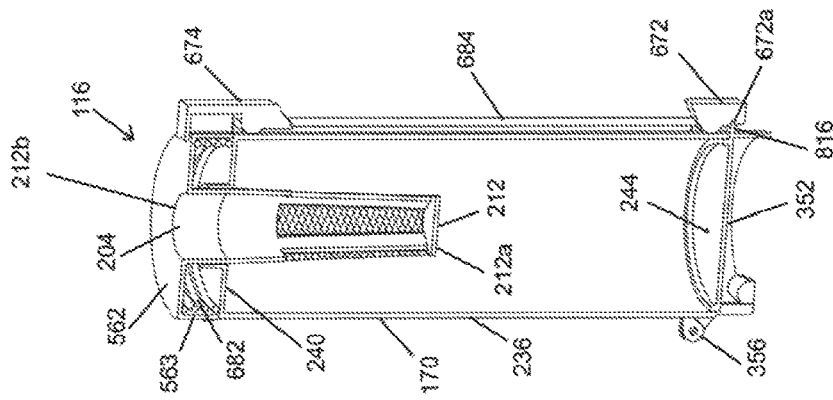

FIG. 164B

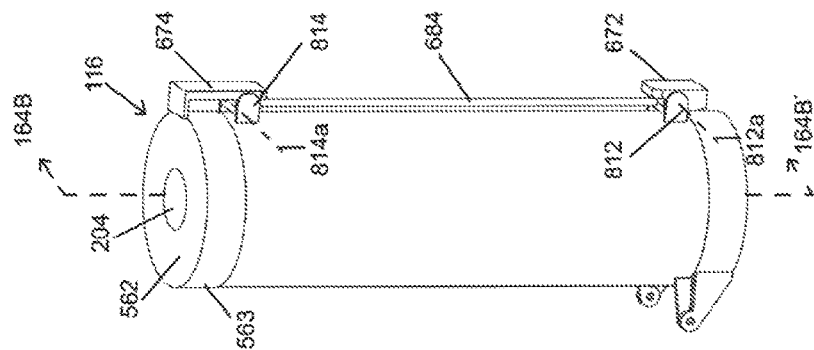

FIG. 164A

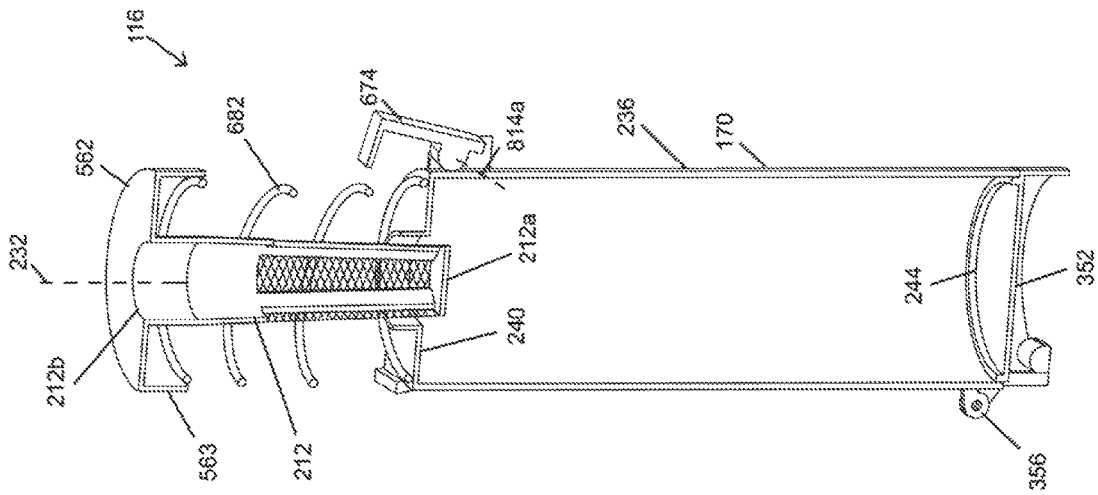

FIG. 165B

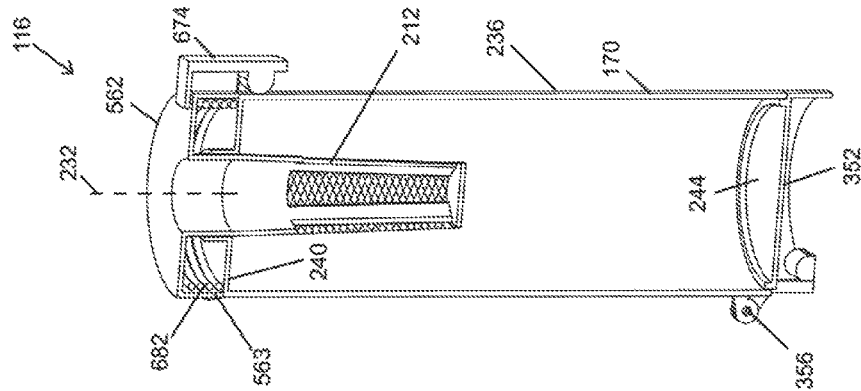

FIG. 165A

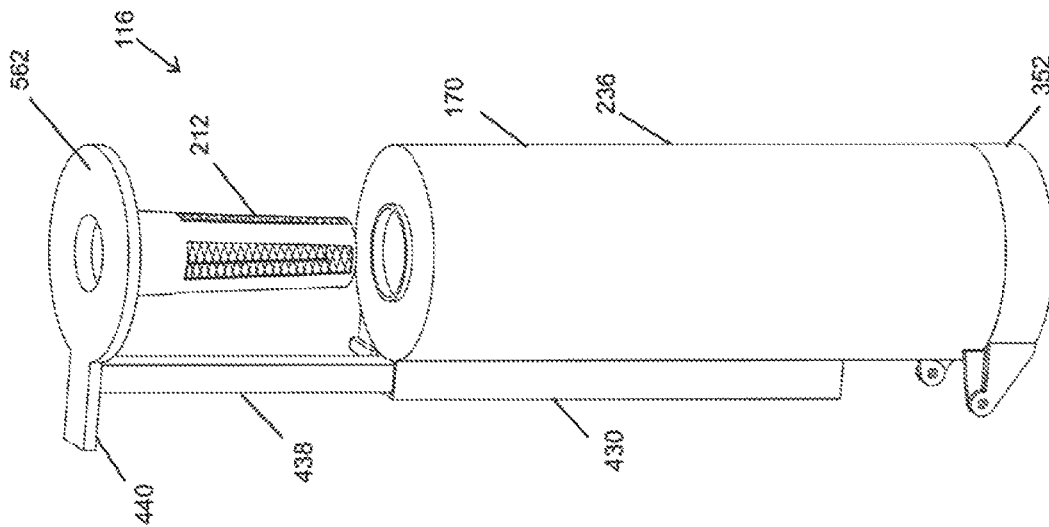

FIG. 166A

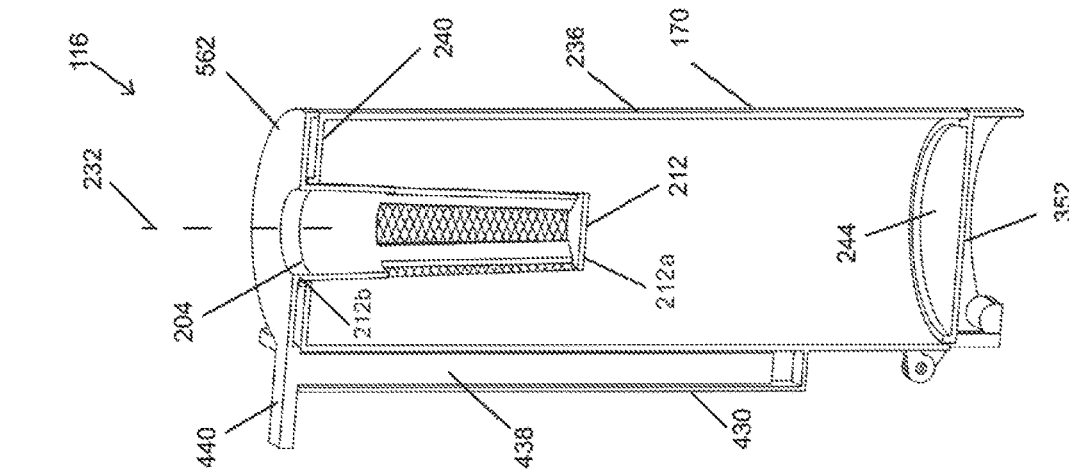

FIG. 166B

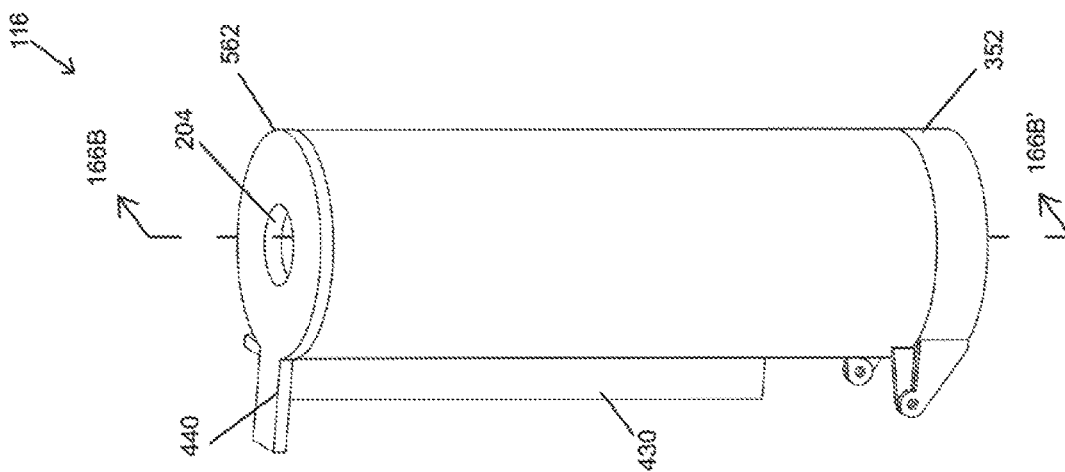

FIG. 166C

1

**SURFACE CLEANING APPARATUS,
CYCLONIC AIR TREATMENT MEMBER
AND SURFACE CLEANING APPARATUS
INCLUDING THE SAME**

CROSS-REFERENCE TO RELATED
APPLICATIONS

This application is a continuation-in-part of U.S. patent application Ser. No. 16/447,308, filed on Jun. 20, 2019, which itself is a continuation-in-part of U.S. patent application Ser. No. 16/254,918, filed on Jan. 23, 2019, the entirety of which is incorporated herein by reference.

FIELD

This application relates to the field of cyclonic air treatment members and surface cleaning apparatus including the same.

INTRODUCTION

The following is not an admission that anything discussed below is part of the prior art or part of the common general knowledge of a person skilled in the art.

Various types of surface cleaning apparatus are known, including upright surface cleaning apparatus, canister surface cleaning apparatus, stick surface cleaning apparatus, central vacuum systems, and hand carryable surface cleaning apparatus such as hand vacuums. Further, various designs for cyclonic hand vacuum cleaners, including battery operated cyclonic hand vacuum cleaners, are known in the art.

SUMMARY

This summary is intended to introduce the reader to the more detailed description that follows and not to limit or define any claimed or as yet unclaimed invention. One or more inventions may reside in any combination or sub-combination of the elements or process steps disclosed in any part of this document including its claims and figures.

In accordance with one broad aspect of this disclosure, which may be used by itself or any other aspect set out herein, a moveable member may be positioned in the air treatment chamber, such as a cyclone. The moveable member may comprise a porous member (such as a screen or shroud) and/or a cleaning member, wherein the cleaning member is positioned between a longitudinally extending outer sidewall of the air treatment chamber and a sidewall of the porous member. A handle may be drivingly connected to the moveable member by a driving linkage wherein part of the driving linkage extends through a longitudinally extending slot in the longitudinally extending outer sidewall. In this configuration, the moveable member is longitudinally translatable through at least a portion of the chamber by a handle that is positioned exterior to the air treatment chamber. Accordingly, a screen or other porous air outlet member may be cleaned without a user inserting their hand into the air treatment member.

In accordance with this broad aspect, there is provided a surface cleaning apparatus comprising:

- (a) an air flow path extending from a dirty air inlet to a clean air outlet;
- (b) an air treatment member having an air treatment chamber positioned in the air flow path, the air treatment chamber comprising an air treatment chamber air inlet, an air treatment chamber air outlet, an openable

2

first end, a longitudinally spaced apart second end having the air treatment chamber air outlet_ and a longitudinally extending sidewall, the sidewall having a longitudinally extending slot, wherein the air treatment chamber air outlet comprises a longitudinally extending porous member having a longitudinally extending porous sidewall;

(c) a suction motor positioned in the air flow path upstream of the clean air outlet;

(d) a moveable member positioned in the air treatment chamber, the moveable member comprising at least one of the porous member and a cleaning member positioned in the air treatment chamber between the sidewall of the air treatment chamber and the porous sidewall; and,

(e) a handle that is drivingly connected to the moveable member by a driving linkage and part of the driving linkage extends through the slot whereby the moveable member is longitudinally translatable through at least a portion of the chamber.

In some embodiments, the moveable member may be moveable from an operating position in which the moveable member is positioned towards the second end and a cleaned position in which the moveable member is translated longitudinally away from the second end.

In some embodiments, in the cleaned position, at least a portion of the moveable member is exterior of the air treatment chamber.

In some embodiments, the moveable member comprises the cleaning member and the cleaning member may be moveable from an operating position in which the cleaning member abuts the second end and a cleaned position in which the moveable member is translated longitudinally away from the second end.

In some embodiments, the cleaning member may comprise an annular member.

In some embodiments, the air treatment member may comprise a cyclone having a centrally positioned cyclone axis of rotation.

In some embodiments, the porous member may be tapered towards the openable first end.

In some embodiments, the surface cleaning apparatus may further comprise a dirt collection chamber external to the air treatment member chamber and the air treatment member chamber has a dirt outlet in communication with the dirt collection chamber, wherein air rotates in a direction of rotation in the air treatment chamber and the slot may be positioned in the sidewall in the direction of rotation downstream from the dirt outlet.

In some embodiments, the slot may be positioned in the sidewall in the direction of rotation up to 90° downstream from the dirt outlet.

In some embodiments, the first end may be openable in response to the moveable member being longitudinally translatable through the chamber.

In some embodiments, the surface cleaning apparatus may further comprise an openable lock operable between a locked position in which the first end is secured in a closed position and an open position in which the first end is moveable to an open position and the lock may be moveable from the locked position to the open position in response to the moveable member being longitudinally translatable through the chamber.

In some embodiments, the driving linkage may operably engage the lock to move the lock from the locked position to the open position as the moveable member is longitudinally translated through the chamber.

In some embodiments, the driving linkage may comprise a longitudinally extending drive rod.

In some embodiments, the driving linkage may operably engage the first end to open the first end as the moveable member is longitudinally translated through the chamber.

In some embodiments, the moveable member may operably engage the lock to move the lock from the locked position to the open position as the moveable member is longitudinally translated through the chamber.

In some embodiments, the slot may have a first longitudinally extending side and a second longitudinally extending side that is spaced from and faces the first longitudinally extending side, wherein the driving linkage may have a portion that travels longitudinally through the slot between the first and second longitudinally extending sides, wherein the first longitudinally extending side meets an inner surface of the sidewall of the air treatment chamber at a first juncture and the first juncture is angled or chamfered.

In some embodiments, the slot has a first longitudinally extending side and a second longitudinally extending side that is spaced from and faces the first longitudinally extending side, wherein the driving linkage has a portion that travels longitudinally through the slot between the first and second longitudinally extending sides, wherein a sealing member is positioned between the first and second longitudinally extending sides. Alternately, or in addition, the sealing member may be placed exterior to the air treatment chamber adjacent the slot (e.g., on an outer wall of the air treatment member adjacent the slot). The sealing member may comprise a deformable member that may be provided on at least one of the first and second longitudinally extending sides or on an outer wall of the air treatment member.

In some embodiments, the air treatment member may be removably mounted to the surface cleaning apparatus and the sealing member may be provided on the surface cleaning apparatus and is removably received in the slot when the air treatment member is mounted on the surface cleaning apparatus. For example, the sealing member comprises a spline.

In accordance with another broad aspect of this disclosure, which may be used by itself or any other aspect set out herein, a moveable member is positioned in an air treatment chamber, and a handle may be drivingly connected to the moveable member by a driving linkage wherein part of the driving linkage extends through an opening in an end wall of the air treatment member. In this configuration, the moveable member is longitudinally translatable axially through at least a portion of the air treatment chamber by using the handle to move the driving linkage axially through the end wall of the air treatment chamber. Accordingly, an end of the air treatment chamber opposed to the end wall may be openable and the axial movement of the handle may push dirt out the open end.

In accordance with this broad aspect, there is provided a surface cleaning apparatus comprising:

- (a) an air flow path extending from a dirty air inlet to a clean air outlet;
- (b) an air treatment member having an air treatment chamber positioned in the air flow path, the air treatment chamber comprising an air treatment chamber air inlet, an air treatment chamber air outlet, an openable first end, a longitudinally spaced apart second end having the air treatment chamber air outlet and a longitudinally extending sidewall, wherein the air treatment chamber air outlet comprises a longitudinally extending porous member having a longitudinally extending porous sidewall;

(c) a suction motor positioned in the air flow path upstream of the clean air outlet;

(d) a moveable member positioned in the air treatment chamber, the moveable member comprising at least one of the porous member and a cleaning member positioned in the air treatment chamber between the sidewall of the air treatment chamber and the porous sidewall; and,

(e) a handle that is drivingly connected to the moveable member by a driving linkage and part of the driving linkage extends through the opening in the second end whereby the moveable member is longitudinally translatable through at least a portion of the chamber.

In some embodiments, the moveable member may be moveable from an operating position in which the moveable member is positioned towards the second end and a cleaned position in which the moveable member is translated longitudinally away from the second end.

In some embodiments, in the cleaned position, at least a portion of the moveable member may be exterior of the air treatment chamber.

In some embodiments, the moveable member may comprise the cleaning member and the cleaning member may be moveable from an operating position in which the cleaning member abuts the second end and a cleaned position in which the moveable member is translated longitudinally away from the second end.

In some embodiments, the cleaning member may comprise an annular member.

In some embodiments, the air treatment member may comprise a cyclone having a centrally positioned cyclone axis of rotation.

In some embodiments, the porous member may be tapered towards the openable first end.

In some embodiments, the surface cleaning apparatus may further comprise a dirt collection chamber external to the air treatment member chamber and the air treatment member chamber may have a dirt outlet in communication with the dirt collection chamber.

In some embodiments, the first end may be openable in response to the moveable member being longitudinally translatable through the chamber.

In some embodiments, the surface cleaning apparatus may further comprise an openable lock operable between a locked position in which the first end is secured in a closed position and an open position in which the first end is moveable to an open position and the lock may be moveable from the locked position to the open position in response to the moveable member being longitudinally translatable through the chamber.

In some embodiments, the driving linkage may operably engage the lock to move the lock from the locked position to the open position as the moveable member is longitudinally translated through the chamber.

In some embodiments, the driving linkage may comprise a longitudinally extending drive rod.

In some embodiments, the driving linkage may operably engage the first end to open the first end as the moveable member is longitudinally translated through the chamber.

In some embodiments, the moveable member may operably engage the lock to move the lock from the locked position to the open position as the moveable member is longitudinally translated through the chamber.

In some embodiments, the driving linkage may have a portion that travels longitudinally through the opening, wherein a sealing member is associated with the opening.

The sealing member may comprise a deformable member provided in or adjacent the opening.

In accordance with another broad aspect of this disclosure, which may be used by itself or any other aspect set out herein, a moveable member (e.g., a cleaning member or a porous air outlet member) is positioned in an air treatment chamber, and a driving assembly, comprising a handle and a driving linkage, is drivingly connected to the moveable member. The driving assembly is reconfigurable between a stored position, and an operable position. In the operating position, the driving assembly is operable to longitudinally translate the moveable member through at least a portion of the air treatment member. When not in use, the driving assembly, e.g., the handle, may be moved to the stored position in which a portion of the driving assembly, e.g., the handle, is positioned to avoid being hit by a user or furniture during use of the surface cleaning apparatus. Therefore, this reduces the likelihood of the driving assembly being damaged when the surface cleaning apparatus is used to clean a surface.

In accordance with this broad aspect, there is provided a surface cleaning apparatus comprising:

- (a) an air flow path extending from a dirty air inlet to a clean air outlet;
- (b) an air treatment member having an air treatment chamber positioned in the air flow path, the air treatment chamber comprising an air treatment chamber air inlet, an air treatment chamber air outlet, an openable first end, a longitudinally spaced apart second end having the air treatment chamber air outlet and a longitudinally extending sidewall, wherein the air treatment chamber air outlet comprises a longitudinally extending porous member having a longitudinally extending porous sidewall;
- (c) a suction motor positioned in the air flow path upstream of the clean air outlet;
- (d) a moveable member positioned in the air treatment chamber, the moveable member comprising at least one of the porous member and a cleaning member positioned in the air treatment chamber between the sidewall of the air treatment chamber and the porous sidewall; and,
- (e) a driving assembly comprising a handle and a driving linkage wherein the driving assembly is reconfigurable between a stored position and an operable position in which the driving assembly is operable to longitudinally translate the moveable member through at least a portion of the chamber.

In some embodiments, the driving linkage may comprise an extendable member wherein, in the stored position, the extendable member is in a contracted configuration and, in the operable position, the extendable member is in an extended configuration in which the handle is operable to longitudinally translate the moveable member through at least a portion of the chamber.

In some embodiments, driving linkage may be drivingly connected to the moveable member when the extendable member is in the contracted configuration.

In some embodiments, the extendable member may comprise a telescoping drive rod.

In some embodiments, the extendable member may comprise a rotatably mounted drive rod, the rotatably mounted drive rod has a longitudinal axis and the rotatably mounted drive rod may be rotatably mounted about an axis that extends in a plane that is transverse to the longitudinal axis of the drive rod.

In some embodiments, the driving linkage may comprise a longitudinally translatable drive rod and the rotatably mounted drive rod may be rotatably mounted to the longitudinally translatable drive rod.

In some embodiments, a portion of the driving linkage may be exterior to the air treatment chamber and in the stored position, the portion of the driving linkage may be recessed against a portion of the surface cleaning apparatus.

In some embodiments, in the stored position, the portion of the driving linkage may be coextensive with a portion of the air treatment member.

In some embodiments, the extendable member may be exterior to the air treatment chamber and in the contracted configuration, the extendable member may be recessed against a portion of the surface cleaning apparatus.

In some embodiments, in the contracted configuration, the extendable member may be coextensive with a portion of the air treatment member.

In some embodiments, the extendable member may have the handle and, in the extended configuration, the handle may be longitudinally spaced from the first and second ends of the air treatment chamber.

In some embodiments, the handle may be rotatably mounted and in the stored position, the handle may be recessed against a portion of the surface cleaning apparatus and in the operable position the handle may be positioned away from the portion of the surface cleaning apparatus.

In some embodiments, in the stored position, the handle may abut the portion of the surface cleaning apparatus.

In some embodiments, the driving linkage may comprise a longitudinally extending drive rod having a drive rod axis and the handle may be rotatable about the drive rod axis.

In some embodiments, the surface cleaning apparatus may further comprise a stop member operably engageable with the driving assembly to inhibit the driving assembly moving to the operable position.

In some embodiments, the moveable member may be moveable from an operating position in which the moveable member is positioned towards the second end and a cleaned position in which the moveable member is translated longitudinally away from the second end.

In some embodiments, in the cleaned position, at least a portion of the moveable member may be exterior of the air treatment chamber.

In some embodiments, the moveable member may comprise the cleaning member and the cleaning member may be moveable from an operating position in which the cleaning member abuts the second end and a cleaned position in which the moveable member is translated longitudinally away from the second end.

In some embodiments, the cleaning member may comprise an annular member.

In some embodiments, the air treatment member may comprise a cyclone having a centrally positioned cyclone axis of rotation.

In accordance with another broad aspect of this disclosure, which may be used by itself or any other aspect set out herein, a moveable member (e.g., a cleaning member or a porous air outlet member) is positioned in an air treatment chamber, and a driving assembly comprising a handle and a driving linkage is connected to the moveable member. The driving assembly is operable between a stored position, in which the surface cleaning apparatus is operable to clean a surface, and a cleaned position, in which the moveable member has been translated through at least a portion of the chamber. In the stored position, a portion of the driving assembly comprising the handle is longitudinally spaced

from the first and second ends of the air treatment chamber and is located adjacent another portion of the surface cleaning apparatus, such as a dirt chamber or motor housing. This reduces the likelihood of the driving assembly being damaged when the surface cleaning apparatus is used to clean a surface.

In accordance with this broad aspect, there is provided a surface cleaning apparatus comprising:

- (a) an air flow path extending from a dirty air inlet to a clean air outlet;
- (b) a first air treatment member having an air treatment chamber positioned in the air flow path, the air treatment chamber comprising an air treatment chamber air inlet, an air treatment chamber air outlet, an openable first end, a longitudinally spaced apart second end having the air treatment chamber air outlet and a longitudinally extending sidewall, wherein the air treatment chamber air outlet comprises a longitudinally extending porous member having a longitudinally extending porous sidewall;
- (c) a suction motor positioned in the air flow path upstream of the clean air outlet;
- (d) a moveable member positioned in the air treatment chamber, the moveable member comprising at least one of the porous member and a cleaning member positioned in the air treatment chamber between the sidewall of the air treatment chamber and the porous sidewall; and,
- (e) a driving assembly comprising a handle and a driving linkage wherein the driving assembly is operable between a stored position in which the surface cleaning apparatus is operable to clean a surface and a cleaned position in which the moveable member has been translated through at least a portion of the chamber, wherein, in the stored position, a portion of the driving assembly comprising the handle is longitudinally spaced from the first and second ends of the air treatment chamber.

In some embodiments, the driving linkage may comprise a drive rod and, in the stored position, at least a portion of the drive rod may extend along another portion of the surface cleaning apparatus.

In some embodiments, the surface cleaning apparatus may further comprise a dirt collection chamber exterior to the air treatment chamber, the air treatment chamber may further comprise a dirt outlet in communication with the portion of the drive rod that is coextensive with a portion of the dirt collection chamber that is longitudinally spaced from the first and second ends of the air treatment chamber.

In some embodiments, the surface cleaning apparatus may further comprise a second stage air treatment member downstream from the first air treatment member and another portion of the surface cleaning apparatus may comprise the second stage air treatment member.

In some embodiments, the first air treatment member may be a first cyclonic stage and the surface cleaning apparatus may further comprise a second cyclonic stage downstream from the first cyclonic stage and the another portion of the surface cleaning apparatus may comprise the second cyclonic stage.

In some embodiments, the surface cleaning apparatus may further comprise a suction motor housing and another portion of the surface cleaning apparatus may comprise the suction motor housing.

In some embodiments, the driving linkage may have a fixed longitudinal length.

In some embodiments, the driving assembly may be reconfigurable between the stored position in which the handle is recessed against a portion of the surface cleaning apparatus and an operable position in which the handle has been rotated away from the portion of the surface cleaning apparatus and the driving assembly is operable to longitudinally translate the moveable member through at least a portion of the chamber.

In some embodiments, the stored position, the handle may abut the portion of the surface cleaning apparatus.

In some embodiments, the driving linkage may comprise a longitudinally extending drive rod having a drive rod axis and the handle is rotatable about the drive rod axis.

In some embodiments, the surface cleaning apparatus may further comprise a stop member operably engageable with the driving assembly to inhibit the handle rotating away from the stored position.

In some embodiments, the driving linkage may comprise an extendable member wherein, in the stored position, the extendable member is in a contracted configuration and, in the operable position, the extendable member is in an extended configuration in which the handle is operable to longitudinally translate the moveable member through at least a portion of the chamber.

In some embodiments, the driving linkage may be drivably connected to the moveable member when the extendable member is in the contracted configuration.

In some embodiments, the extendable member may comprise a telescoping drive rod.

In some embodiments, the moveable member may be moveable from an operating position in which the moveable member is positioned towards the second end and a cleaned position in which the moveable member is translated longitudinally away from the second end.

In some embodiments, in the cleaned position, at least a portion of the moveable member may be exterior of the air treatment chamber.

In some embodiments, the moveable member may comprise the cleaning member and the cleaning member may be moveable from an operating position in which the cleaning member abuts the second end and a cleaned position in which the moveable member is translated longitudinally away from the second end.

In some embodiments, the cleaning member may comprise an annular member.

In some embodiments, the air treatment member may comprise a cyclone having a centrally positioned cyclone axis of rotation.

In accordance with another broad aspect of this disclosure, which may be used by itself or any other aspect set out herein, a moveable member (e.g., a cleaning member or a porous air outlet member) is positioned in an air treatment chamber, and a handle is drivably connected to the moveable member. The moveable member is longitudinally translatable through at least a portion of the chamber and the first end of the air treatment member is openable in response to the moveable member being longitudinally translatable through at least the portion of the chamber. Accordingly, the air treatment member may be automatically opened when, e.g., a cleaning member, is used to clean an outlet screen of the air treatment chamber.

In accordance with this broad aspect, there is provided a surface cleaning apparatus comprising:

- (a) an air flow path extending from a dirty air inlet to a clean air outlet;
- (b) an air treatment member having an air treatment chamber positioned in the air flow path, the air treat-

ment chamber comprising an air treatment chamber air inlet, an air treatment chamber air outlet, an openable first end, a longitudinally spaced apart second end having the air treatment chamber air outlet and a longitudinally extending sidewall, wherein the air treatment chamber air outlet comprises a longitudinally extending porous member having a longitudinally extending porous sidewall;

- (c) a suction motor positioned in the air flow path upstream of the clean air outlet;
- (d) a moveable member positioned in the air treatment chamber, the moveable member comprising at least one of the porous member and a cleaning member positioned in the air treatment chamber between the sidewall of the air treatment chamber and the porous sidewall, wherein the moveable member is moveable from an operating position in which the moveable member is positioned towards the second end and a cleaned position in which the moveable member is translated longitudinally away from the second end; and,
- (e) a handle drivably connected to the moveable member whereby the moveable member is longitudinally translatable through at least a portion of the chamber, wherein the first end is openable in response to the moveable member being longitudinally translatable through at least the portion of the chamber.

In some embodiments, the surface cleaning apparatus may further comprise an openable lock operable between a locked position in which the first end is secured in a closed position and an open position in which the first end is moveable to an open position, and the lock may be moveable from the locked position to the open position in response to the moveable member being longitudinally translatable through at least the portion of the chamber.

In some embodiments, the driving linkage may operably engage the lock to move the lock from the locked position to the open position as the moveable member is longitudinally translated through at least the portion of the chamber.

In some embodiments, the driving linkage may comprise a longitudinally extending drive rod.

In some embodiments, the driving linkage may operably engage the first end to open the first end as the moveable member is longitudinally translated through the chamber.

In some embodiments, the driving linkage may operably engage the first end to open the first end as the moveable member is longitudinally translated through at least the portion of the chamber.

In some embodiments, the moveable member may comprise the cleaning member and the cleaning member may operably engage the first end to open the first end as the cleaning member is longitudinally translated through at least the portion of the chamber.

In some embodiments, the moveable member may comprise the porous member and the porous member may operably engage the first end to open the first end as the porous member is longitudinally translated through at least the portion of the chamber.

In some embodiments, the moveable member may comprise the cleaning member and the cleaning member may operably engage the lock to move the lock from the locked position to the open position as the cleaning member is longitudinally translated through at least the portion of the chamber.

In some embodiments, the cleaning member may operably engage the first end to open the first end as the cleaning member is longitudinally translated through at least the portion of the chamber.

In some embodiments, the moveable member may comprise the porous member and the porous member may operably engage the lock to move the lock from the locked position to the open position as the porous member is longitudinally translated through at least the portion of the chamber.

In some embodiments, the porous member may operably engage the first end to open the first end as the porous member is longitudinally translated through at least the portion of the chamber.

In some embodiments, in the cleaned position, at least a portion of the moveable member may be exterior of the air treatment chamber.

In some embodiments, the moveable member may comprise the cleaning member and the cleaning member may be moveable from an operating position in which the cleaning member abuts the second end and a cleaned position in which the moveable member is translated longitudinally away from the second end.

In some embodiments, the cleaning member may comprise an annular member. Optionally the annular member may have a plurality of finger members depending longitudinally therefrom. Optionally, the finger members may depend from a radially outward portion of the annular member.

In some embodiments, the air treatment member may comprise a cyclone having a centrally positioned cyclone axis of rotation.

In some embodiments, the porous member may be tapered towards the openable first end.

It will be appreciated by a person skilled in the art that an apparatus or method disclosed herein may embody any one or more of the features contained herein and that the features may be used in any particular combination or sub-combination.

These and other aspects and features of various embodiments will be described in greater detail below.

BRIEF DESCRIPTION OF THE DRAWINGS

For a better understanding of the described embodiments and to show more clearly how they may be carried into effect, reference will now be made, by way of example, to the accompanying drawings in which:

FIG. 1 is a perspective view of a surface cleaning apparatus in accordance with an embodiment;

FIG. 2 is a cross-sectional view taken along line 2-2 in FIG. 1;

FIG. 3 is a perspective view of a surface cleaning apparatus in accordance with an embodiment;

FIG. 4 is a cross-sectional view taken along line 4-4 in FIG. 3;

FIG. 5 is a perspective view of an air treatment member in an open position, in accordance with an embodiment;

FIG. 6 is a cross-sectional view taken along line 6-6 in FIG. 5;

FIG. 7 is a cross-sectional view taken along line 6-6 in FIG. 5, in accordance with another embodiment;

FIG. 8 is a cross-sectional view taken along line 6-6 in FIG. 5, in accordance with another embodiment;

FIG. 9 is a cross-sectional view taken along line 6-6 in FIG. 5, in accordance with another embodiment;

11

FIG. 10 is a cross-sectional view of an air treatment member, in a closed position, in accordance with another embodiment;

FIG. 11 is a cross-sectional view of the air treatment member of FIG. 10, in an open position;

FIG. 12 is a cross-sectional view of the air treatment member of FIG. 10, in an open position, with a cyclone outlet passage removed in accordance with an embodiment;

FIG. 13 is a cross-sectional view of the air treatment member of FIG. 10, in an open position, with the cyclone outlet passage translated in accordance with an embodiment;

FIG. 14 is a perspective view of an air treatment member in an open position, in accordance with an embodiment;

FIG. 15 is a perspective view of an air treatment member in an open position and with the cyclone outlet passage rotated out of a cyclone chamber, in accordance with an embodiment;

FIG. 16 is a perspective view of an air treatment member in an open position with the cyclone outlet passage rotated out of the cyclone chamber and an open end door in accordance with an embodiment;

FIG. 17 is a perspective view of the air treatment member of FIG. 16 with a closed sidewall and an open end door in accordance with an embodiment;

FIG. 18 is a perspective view of an air treatment member in an open position with an open end door in accordance with an embodiment;

FIG. 19 is a perspective view of an air treatment member with a sidewall portion opened slightly;

FIG. 20 is a perspective view of the air treatment member of FIG. 19 with the sidewall portion opened fully;

FIG. 21 is a perspective view of the air treatment member of FIG. 19 with the sidewall portion opened fully and an axially extending member rotated;

FIG. 22 is a perspective view of an air treatment member in an open position in accordance with an embodiment;

FIG. 23 is a perspective view of an air treatment member in an open position and with an open end door in accordance with an embodiment;

FIG. 24 is a perspective view of the air treatment member of FIG. 22 in the open position and with open end doors;

FIG. 25 is a perspective view of an air treatment member in an open position in accordance with an embodiment;

FIG. 26 is a perspective view of the air treatment member of FIG. 25 in the open position with the cyclone outlet passage rotated out of the cyclone chamber;

FIGS. 27-30 are perspective views of the air treatment member transitioning from a closed position in FIG. 27 to an open position in FIG. 30, in accordance with an embodiment;

FIG. 31 is a perspective view of an air treatment member with an axially translatable sidewall portion, in an open position, in accordance with an embodiment;

FIG. 32 is a perspective view of the air treatment member of FIG. 31 with the sidewall portion in a closed position and an open end wall;

FIG. 33 is a perspective view of the air treatment member of FIG. 31 in an open position with the cyclone outlet passage rotated out of the cyclone chamber in accordance with an embodiment;

FIG. 34 is a perspective view of an air treatment member in an open position in accordance with an embodiment;

FIG. 35 is a perspective view of an air treatment member in accordance with an embodiment;

FIG. 36 is a cross-sectional view of the air treatment member of FIG. 35 taken along the section line 36-36' in FIG. 35;

12

FIG. 37 is a cross-sectional view of the air treatment member of FIG. 35 taken along the section line 37-37' in FIG. 35, in accordance with some embodiments;

FIG. 38 is a cross-sectional view of the air treatment member of FIG. 35 along the section line 36-36', in accordance with another embodiment;

FIG. 39 is a perspective cross-sectional view of the air treatment member of FIG. 35 taken along section line 37-37' in FIG. 35, in accordance with the embodiment of FIG. 38;

FIG. 40 is a perspective view of the air treatment member of FIG. 38 with an open end wall, in accordance with some embodiments;

FIG. 41 is a perspective cross-sectional view of the air treatment member of FIG. 40 taken along the section line 41-41' in FIG. 40;

FIG. 42 is a cross-sectional view of the air treatment member of FIG. 39 taken along the section line 42-42', according to some embodiments;

FIG. 43 is a sectional perspective of view of the air treatment member of FIG. 35 taken along the section line 43-43' of FIG. 35;

FIGS. 44A-44H are cross-sectional views of the air treatment member of FIG. 39 taken along the section line 42-42' in FIG. 39, according to various different embodiments;

FIG. 45 is a cross-sectional view of the air treatment member of FIG. 35 taken along the section line 36-36' in FIG. 35, in accordance with another embodiment;

FIG. 46 is a cross-sectional view of the air treatment member of FIG. 35 taken along the section line 36-36' in FIG. 35, in accordance with another embodiment;

FIG. 47 is a cross-sectional view of the air treatment member of FIG. 35 taken along the section line 36-36' in FIG. 35, in accordance with another embodiment;

FIG. 48 is a perspective cross-sectional view of the air treatment member of FIG. 37 taken along the section line 36-36' in FIG. 35 showing an opened end wall;

FIG. 49 is a cross-sectional view of the air treatment member of FIG. 35 taken along the section line 37-37' in FIG. 35, in accordance with an embodiment;

FIG. 50 is a cross-sectional view of the air treatment member of FIG. 35 taken along the section line 37-37' in FIG. 35, in accordance with another embodiment;

FIG. 51 is a cross-sectional view of the air treatment member of FIG. 35 taken along the section line 36-36' in FIG. 35, in accordance with an embodiment;

FIGS. 52-57 are cross-sectional views of the air treatment member of FIG. 51 taken along the section line 52-52' in FIG. 51, in accordance with various different embodiments;

FIG. 58 is a perspective cross-sectional view of the air treatment member of FIG. 35 taken along the section line 36-36' in FIG. 35, in accordance with some embodiments;

FIG. 59 is a cross-sectional view of the air treatment member of FIG. 49 taken along the section line 59-59';

FIG. 60 is a perspective cross-sectional view of the air treatment member of FIG. 35 taken along the section line 37-37' in FIG. 35, according to some embodiments;

FIG. 61 is a perspective cross-sectional view of the air treatment member of FIG. 35 taken along the section line 37-37' in FIG. 35, according to some embodiments;

FIG. 62 is a cross-sectional view of the air treatment member of FIG. 35 taken along the section line 37-37' in FIG. 35, according to some embodiments;

FIG. 63 is a cross-sectional view of the air treatment member of FIG. 35 taken along the sectional line 36-36' in FIG. 35 showing an opened end wall, in accordance with some embodiments;

13

FIGS. 64-67 are perspective views of vertical screens, according to various different embodiments;

FIG. 68A is a perspective view of a vertical screen, according to another embodiment;

FIG. 68B is a top-down view of the vertical screen of FIG. 68A;

FIG. 68C is a side-view of the vertical screen of FIG. 68A;

FIG. 69A is a perspective view of a vertical screen, according to another embodiment;

FIG. 69B is a top-down view of the vertical screen of FIG. 69A;

FIG. 69C is a side-view of the vertical screen of FIG. 69A;

FIG. 70A is a perspective view of a vertical screen, according to another embodiment;

FIG. 70B is a top-down view of the vertical screen of FIG. 70A;

FIG. 70C is a side-view of the vertical screen of FIG. 70A;

FIG. 71A is a perspective view of a vertical screen, according to another embodiment;

FIG. 71B is a top-down view of the vertical screen of FIG. 71A;

FIG. 71C is a side-view of the vertical screen of FIG. 71A;

FIG. 72A is a perspective view of vertical screens, according to another embodiment;

FIG. 72B is a top-down view of the vertical screens of FIG. 72A;

FIG. 72C is a side-view of the vertical screens of FIG. 72A;

FIG. 73A is a perspective view of vertical screens, according to another embodiment;

FIG. 73B is a top-down view of the vertical screens of FIG. 73A;

FIG. 73C is a side-view of the vertical screens of FIG. 73A;

FIG. 74A is a perspective view of a vertical screen, according to another embodiment;

FIG. 74B is a top-down view of the vertical screen of FIG. 74A;

FIG. 74C is a side-view of the vertical screen of FIG. 74A;

FIG. 75A is a perspective view of vertical screens, according to another embodiment;

FIG. 75B is a top-down view of the vertical screens of FIG. 75A;

FIG. 75C is a side-view of the vertical screens of FIG. 75A;

FIG. 76A is a perspective view of a vertical screen, according to another embodiment;

FIG. 76B is a top-down view of the vertical screen of FIG. 76A;

FIG. 76C is a side-view of the vertical screen of FIG. 76A;

FIG. 77A is a perspective view of a vertical screen, according to another embodiment;

FIG. 77B is a top-down view of the vertical screen of FIG. 77A;

FIG. 77C is a side-view of the vertical screen of FIG. 77A;

FIG. 78A is a perspective view of a vertical screen, according to another embodiment;

FIG. 78B is a top-down view of the vertical screen of FIG. 78A;

14

FIG. 78C is a side-view of the vertical screen of FIG. 78A;

FIG. 79 is a cross-sectional view of the air treatment member of FIG. 35 taken along the section line 79-79' in FIG. 35, in accordance with some embodiments;

FIG. 80 is the cross-sectional view of the air treatment member of FIG. 79 with an opened end wall;

FIG. 81 is the cross-sectional view of the air treatment member of FIG. 79, in accordance with some other embodiments;

FIG. 82 is the cross-sectional view of the air treatment member of FIG. 81 with an opened end wall;

FIG. 83 is the cross-sectional view of the air treatment member of FIG. 79, in accordance with another embodiment;

FIG. 84 is a perspective view of a surface cleaning apparatus in accordance with an embodiment;

FIG. 85A is a perspective cross-sectional view of an air treatment member of the surface cleaning apparatus of FIG. 84 taken along sectional line 85-85' of FIG. 84 showing a cleaning member in a storage configuration;

FIG. 85B is a perspective cross-sectional view of the air treatment member of FIG. 85A showing the cleaning member in an in-use configuration;

FIG. 86 is a cross-sectional view of the air treatment member of FIG. 85A taken along the section line 86-86' in FIG. 85, according to some embodiments;

FIGS. 87A-87E are perspective cross-sectional views of the air treatment member of FIG. 84 taken along the section line 85-85' in FIG. 84, showing a cleaning member and handle assembly transitioning from a storage configuration to an in-use or emptying configuration, and then back to a storage configuration, in accordance with an embodiment;

FIG. 88 is a perspective cross-sectional view of the air treatment member of FIG. 84 taken along the section line 85-85' showing the cleaning member and handle assembly in an in-use configuration, in accordance with some embodiments;

FIGS. 89A-89C are perspective cross-sectional views of the air treatment member of FIG. 84 taken along the section line 85-85' in FIG. 84 in accordance with another embodiment, showing the cleaning member and handle assembly transitioning from a storage configuration to an emptying configuration;

FIG. 90A is a perspective cross-sectional view of the air treatment member of FIG. 84 taken along the section line 85-85' in FIG. 84 showing a multi-inlet cyclone, in accordance with some embodiments;

FIG. 90B is a side perspective view of a cleaning member, in accordance with some embodiments;

FIG. 90C is a bottom-side perspective view of the cleaning member of FIG. 90B;

FIG. 91 is a perspective cross-sectional view of the air treatment member of FIG. 90A showing the cleaning member in a cleaning configuration;

FIG. 92A is a perspective view of an air treatment member, in accordance with an embodiment;

FIG. 92B is a perspective view of the air treatment member of FIG. 92A showing a perspective cross-sectional view of a track for a handle assembly which is taken along section line 92B-92B' of FIG. 92A;

FIG. 92C is a perspective cross-sectional view of the air treatment member of FIG. 92A, taken along the section line 92C-92C' of FIG. 92B, showing the cleaning member and handle assembly in a storage configuration;

FIG. 93A is a perspective view of the air treatment member of FIG. 92A showing an opened end wall;

FIG. 93B is a perspective view of the air treatment member of FIG. 93 showing a perspective cross-sectional view of the track for the handle assembly taken along the section line 93B-93B' of FIG. 93A;

FIG. 93C is a perspective cross-sectional view of the air treatment member of FIG. 93A, taken along the section line 93C-93C' of FIG. 93B, showing an opened end wall;

FIG. 94A is the perspective cross-sectional view of the air treatment member of FIG. 92C, showing a handle of the handle assembly in a storage position;

FIG. 94B is an enlarged perspective view of a portion of the air treatment member of FIG. 94A, showing the handle in the storage position;

FIG. 95A is the perspective cross-sectional view of the air treatment member of FIG. 92C, showing a handle of the handle assembly in an in-use position;

FIG. 95B is an enlarged perspective view of a portion of the air treatment member of FIG. 95B, showing the handle in the in-use position;

FIG. 96 is a perspective view of an external dirt chamber of an air treatment member, according to some embodiments;

FIG. 97 is a perspective view of the external dirt chamber of the air treatment member of FIG. 96, showing a partially opened end wall;

FIG. 98 is a perspective view of the external dirt chamber of the air treatment member of FIG. 96, showing an opened end wall;

FIG. 99 is a perspective cross-sectional view of the external dirt chamber of the air treatment member of FIG. 96 taken along section line 99-99' of FIG. 96, in accordance with some other embodiments;

FIG. 100 is a perspective cross-sectional view of the external dirt chamber of FIG. 99, showing a partially opened end wall;

FIG. 101 is a perspective cross-sectional view of the external dirt chamber of FIG. 99, showing an opened end wall;

FIG. 102A is a perspective cross-sectional view of the air treatment member of FIG. 84, taken along the section line 85-85' of FIG. 84, showing the cleaning member in a storage position, in accordance with some embodiments;

FIG. 102B is a perspective cross-sectional view of the air treatment member of FIG. 84, taken along the section line 85-85' of FIG. 84, showing the cleaning member in a cleaned position, in accordance with some embodiments;

FIG. 102C is a cross-sectional view of the air treatment member of FIG. 102A, taken along the section line 102C-102C' of FIG. 102A;

FIGS. 103A-103E are enlarged cross-sectional views of a telescoping elongate rod, used in a driving assembly in an air treatment member, taken along section line 85-85' of FIG. 84, showing the elongate rod extended from a retracted storage position to an extended use position;

FIG. 104A is a perspective view of an air treatment member with a driving assembly extending through a first cyclone end;

FIG. 104B is an enlarged perspective view of a portion of the air treatment member of FIG. 104A;

FIG. 105 is a perspective cross-sectional view of the air treatment member of FIG. 104A, taken along the section line 105-105' of FIG. 104A;

FIGS. 106A-106E are perspective cross-sectional views of the air treatment member of FIG. 104A, taken along the section line 105-105' of FIG. 104A, showing the cleaning member translated from a storage position to various cleaned positions;

FIG. 107A is an enlarged perspective cross-sectional view of a portion of the air treatment member of FIG. 104A, taken along the section line 105-105' of FIG. 104A, showing a door locking mechanism in a locked configuration;

FIG. 107B is an enlarged perspective cross-sectional view of a portion of the air treatment member of FIG. 104A, taken along the section line 105-105' of FIG. 104A, showing the door locking mechanism in an unlocked configuration;

FIGS. 108A-108C are perspective cross-sectional views of the air treatment member of FIG. 104A, taken along the section line 105-105' of FIG. 104A, showing the cleaning member and shroud translated from a storage position to various cleaned positions;

FIG. 109A is a perspective view of an alternate embodiment of the air treatment member of FIG. 104A, wherein the driving assembly is in a retracted storage position;

FIG. 109B is a perspective view of the air treatment member of FIG. 109A, showing the driving assembly in an extended use position;

FIG. 110A is a perspective view of an alternate embodiment of the air treatment member of FIG. 104A, wherein the driving assembly is in a retracted storage position;

FIG. 110B is a perspective view of the air treatment member of FIG. 110A, showing the driving assembly in an extended use position;

FIG. 111A is a perspective view of an air treatment member having a driving assembly extending through a second cyclone end;

FIG. 111B is a perspective cross-sectional view of the air treatment member of FIG. 111A, taken along the section line 111B-111B' of FIG. 111A;

FIG. 111C is a bottom-up, inverted perspective view of the air treatment member of FIG. 111A;

FIGS. 112A-112F are perspective cross-sectional views of the air treatment member of FIG. 111A, taken along the section line 111B-111B' of FIG. 111A, showing the cleaning member translated to various cleaned positions;

FIGS. 113A-113C are perspective cross-sectional views of the air treatment member of FIG. 111A, taken along the section line 111B-111B' of FIG. 111A, showing the cleaning member and shroud translated to various cleaned positions;

FIG. 114 is a perspective view of an alternate embodiment of a surface cleaning apparatus;

FIG. 115 is a perspective cross-sectional view of the surface cleaning apparatus of FIG. 114, taken along the section line 115-115' of FIG. 114;

FIG. 116A is a partial perspective view of the surface cleaning apparatus of FIG. 114, showing an air treatment member mounted to an upright section of the surface cleaning apparatus;

FIG. 116B is a perspective cross-sectional view of FIG. 116A, taken along the section line 116B-116B' of FIG. 116A;

FIG. 116C is a perspective cross-sectional view of FIG. 116A, taken along the section line 116C-116C' of FIG. 116B;

FIG. 117A is a perspective cross-sectional view, taken along section line 116B-116B' of FIG. 116A, showing the air treatment member of FIG. 116A being dismounted from the surface cleaning apparatus;

FIG. 117B is a perspective view of the air treatment member of FIG. 116A, showing the air treatment member dismounted from the surface cleaning apparatus;

FIG. 117C is a perspective view of the air treatment member of FIG. 116A when dismounted from the surface cleaning apparatus;

FIG. 118A is a perspective view of an alternate air treatment member;

FIG. 118B is a perspective cross-sectional view of the air treatment member of FIG. 118A, taken along the section line 118B-118B' of FIG. 118A;

FIG. 118C a perspective cross-sectional view of the air treatment member of FIG. 118A, taken along the section line 118C-118C' of FIG. 118A;

FIG. 118D a cross-sectional view of the air treatment member of FIG. 118A, taken along the section line 118D-118D' of FIG. 118A;

FIGS. 119A-119F are cross-sectional views of various embodiments of the air treatment member of FIG. 118A, taken along the section line 119-119' of FIG. 118A;

FIG. 120A is a perspective view of the air treatment member of FIG. 118A, showing the air treatment member mounted to an upright section of the surface cleaning apparatus of FIG. 114;

FIG. 120B is a perspective cross-sectional view, taken along the section line 120B-120B' of FIG. 120A;

FIG. 120C is a perspective cross-sectional view taken along the section line 120C-120C' of FIG. 120A, showing the air treatment member being dismantled from the upright section of the surface cleaning apparatus of FIG. 114;

FIGS. 121A-121C are cross-sectional views of an embodiment of the air treatment member of FIG. 117C, taken along the section line 121A-121A' of FIG. 117C, showing the cleaning member translated to various cleaned positions;

FIG. 122A is an enlarged view of a portion of the cross-sectional view of FIG. 121A showing a door locking mechanism in a locked position;

FIG. 122B is an enlarged view of a portion of the cross-sectional view of FIG. 121B showing the door locking mechanism in an unlocked position;

FIG. 123A is a perspective view of an alternate embodiment of an air treatment member;

FIG. 123B is a perspective cross-sectional view of the air treatment member of FIG. 123A, taken along the section line 123B-123B' of FIG. 123A showing a door locking mechanism in a locked position;

FIG. 123C is a perspective cross-sectional view of the air treatment member of FIG. 123A, taken along the section line 123B-123B' of FIG. 123A showing the door locking mechanism in an unlocked position;

FIG. 124A is a perspective view of an alternate air treatment member;

FIG. 124B is a perspective cross-sectional view of the air treatment member of FIG. 124A, taken along the section line 124B-124B' of FIG. 124A showing a door locking mechanism in a locked position;

FIG. 124C is a perspective cross-sectional view of the air treatment member of FIG. 124A, taken along the section line 124B-124B' of FIG. 124A showing the door locking mechanism in an unlocked position;

FIG. 125A is a perspective view of an alternate air treatment member;

FIG. 125B is a perspective cross-sectional view of the air treatment member of FIG. 125A, taken along the section line 125B-125B' of FIG. 125A showing the cleaning member in a storage position;

FIG. 125C is a perspective cross-sectional view of the air treatment member of FIG. 125A, taken along the section line 125B-125B' of FIG. 125A showing the cleaning member in a cleaned position;

FIGS. 126A-126D are perspective cross-sectional views of an embodiment of the air treatment member of FIG. 117C, taken along the section line 121A-121A' of FIG. 117C,

showing the cleaning member translated from a storage position to various cleaned positions;

FIGS. 127A-127E are perspective cross-sectional views of an embodiment of the air treatment member of FIG. 117C, taken along the section line 121A-121A' of FIG. 117C, showing the cleaning member and shroud translated from a storage position to various cleaned positions;

FIG. 128 is an enlarged perspective cross-sectional view of a portion of the air treatment member of FIG. 117C, according to another embodiment, taken along the section line 121A-121A' of FIG. 117C, showing the cleaning member and shroud in a storage position;

FIGS. 129A-129D are perspective cross-sectional views of the air treatment member of FIG. 128, taken along the section line 121A-121A' of FIG. 117C, showing the cleaning member and shroud translated to various cleaned positions;

FIG. 130 is an enlarged perspective cross-sectional view of a portion of the air treatment member of FIG. 117C, according to still another embodiment, taken along the section line 121A-121A' of FIG. 117C, showing the cleaning member in a storage position;

FIGS. 131A-131D are perspective cross-sectional views of the air treatment member of FIG. 130, taken along the section line 121A-121A' of FIG. 117C, showing the cleaning member translated to various cleaned positions;

FIG. 132 is a perspective view of an alternate air treatment member;

FIG. 133A is a perspective cross-sectional view of the air treatment member of FIG. 132, taken along the section line 133A-133A' of FIG. 132, showing the cleaning member in a storage position;

FIG. 133B is an enlarged perspective cross-sectional view of a portion of the air treatment member of FIG. 132, taken along the section line 133A-133A' of FIG. 132;

FIGS. 134A-134E are perspective cross-sectional views of the air treatment member of FIG. 132, taken along the section line 133A-133A' of FIG. 132, showing the cleaning member translated to various cleaned positions;

FIG. 135A is a perspective view of an alternate air treatment member;

FIG. 135B is a perspective cross-sectional view of the air treatment member of FIG. 135A, taken along the section line 135B-135B' of FIG. 135A, showing the cleaning member in a storage position;

FIGS. 136A-136E are perspective cross-sectional views of the air treatment member of FIG. 135A, taken along the section line 135B-135B' of FIG. 135A, showing the cleaning member translated to various cleaned positions;

FIG. 137A is a perspective view of an alternate air treatment member;

FIG. 137B is a side elevation view of the air treatment member of FIG. 137A;

FIG. 137C is a perspective cross-sectional view of the air treatment member of FIG. 137A, taken along the section line 137C-137C' of FIG. 137A, showing the cleaning member in a storage position;

FIG. 138A is a side elevation view of the air treatment member of FIG. 137A, showing the cleaning member translated to a cleaned position;

FIG. 138B is a perspective cross-sectional view of the air treatment member of FIG. 138A, taken along the section line 137C-137C' of FIG. 137A;

FIG. 139A is a side elevation view of the air treatment member of FIG. 137A, showing the cleaning member translated further into a cleaned position;

FIG. 139B is a perspective cross-sectional view of the air treatment member of FIG. 138A, taken along the section line 137C-137C' of FIG. 137A;

FIG. 140A is a perspective view of an alternate air treatment member;

FIG. 140B is a perspective cross-sectional view of the air treatment member of FIG. 140A, taken along the section line 140B-140B' of FIG. 140A, showing the cleaning member in a storage position;

FIGS. 141A-141E are perspective cross-sectional views of the air treatment member of FIG. 140A, taken along the section line 140B-140B' of FIG. 140A, showing the cleaning member translated to various cleaned positions;

FIG. 142A is a perspective view of an alternate air treatment member;

FIG. 142B is a perspective cross-sectional view of the air treatment member of FIG. 142A, taken along the section line 142B-142B' of FIG. 142A, showing the cleaning member in a storage position;

FIG. 142C is a side elevation view of the air treatment member of FIG. 142A, showing the cleaning member translated into a cleaned position;

FIGS. 143A-143D show perspective cross-sectional views of the air treatment member of FIG. 142A, taken along the section line 142B-142B' of FIG. 142A, showing the cleaning member translated to various cleaned positions;

FIG. 144 is a perspective view of an alternate air treatment member;

FIG. 145A is a side elevation view of the air treatment member of FIG. 144;

FIG. 145B is a perspective cross-sectional view of the air treatment member of FIG. 144, taken along the section line 145B-145B' of FIG. 144, showing the cleaning member in a storage position;

FIG. 146A is a side elevation view of the air treatment member of FIG. 144, showing the cleaning member translated into a cleaned position;

FIG. 146B is a perspective cross-sectional view of the air treatment member of FIG. 146A, taken along the section line 145B-145B' of FIG. 144;

FIG. 147A is a side elevation view of the air treatment member of FIG. 144, showing the cleaning member translated further into a cleaned position;

FIG. 147B is a perspective cross-sectional view of the air treatment member of FIG. 147A, taken along the section line 145B-145B' of FIG. 144;

FIG. 148A is a perspective view of an alternate air treatment member;

FIG. 148B is a perspective cross-sectional view of the air treatment member of FIG. 148A, taken along the section line 148B-148B' of FIG. 148A, showing the cleaning member in a storage position;

FIG. 148C is an enlarged view of a portion of the perspective cross-sectional view of FIG. 148B;

FIGS. 149A-149E are perspective cross-sectional views of the air treatment member of FIG. 148A, taken along the section line 148B-148B' of FIG. 148A, showing the cleaning member translated to various cleaned positions;

FIG. 150 is a perspective view of an alternate air treatment member;

FIGS. 151A-151C are perspective cross-sectional views of the air treatment member of FIG. 150, taken along the section line 151-151' of FIG. 150, showing the cleaning member translated from a storage position to various cleaned positions;

FIG. 152 is a perspective view of an alternate air treatment member;

FIGS. 153A-153C are perspective cross-sectional views of the air treatment member of FIG. 152, taken along the section line 153-153' of FIG. 152, showing the cleaning member translated from a storage position to various cleaned positions;

FIG. 154A is a perspective view of an alternate air treatment member;

FIG. 154B is a perspective cross-sectional view of the air treatment member of FIG. 154A, taken along the section line 154B-154B' of FIG. 154A, showing the shroud in a storage position;

FIG. 154C is an enlarged view of a portion of the cross-sectional view of FIG. 154B;

FIG. 155A is a perspective view of the air treatment member of FIG. 154A, with the shroud translated into a cleaned position;

FIG. 155B is a perspective cross-sectional view of the air treatment member of FIG. 155A, taken along the section line 155B-155B' of FIG. 155A;

FIG. 156A is a perspective view of the air treatment member of FIG. 154A, with the shroud translated further into a cleaned position;

FIG. 156B is a perspective cross-sectional view of the air treatment member of FIG. 155A, taken along the section line 156B-156B' of FIG. 156A;

FIG. 157A is a perspective view of an alternate air treatment member;

FIG. 157B is a perspective cross-sectional view of the air treatment member of FIG. 157A, taken along the section line 157B-157B' of FIG. 157A;

FIGS. 158A-158E are perspective cross-sectional views of the air treatment member of FIG. 157A, taken along the section line 157B-157B' of FIG. 157A, showing the cleaning member translated from a storage position to various cleaned positions;

FIG. 159A is a perspective view of an alternate air treatment member;

FIG. 159B is a perspective cross-sectional view of the air treatment member of FIG. 159A, taken along the section line 159B-159B' of FIG. 159A;

FIGS. 160A-160E are perspective cross-sectional views of the air treatment member of FIG. 159A, taken along the section line 159B-159B' of FIG. 159A, showing the cleaning member translated from a storage position to various cleaned positions;

FIG. 161A is a perspective view of an alternate air treatment member;

FIG. 161B is a perspective cross-sectional view of the air treatment member of FIG. 161A, taken along section line 161B-161B' of FIG. 161A, showing the driving assembly in a retracted storage position;

FIG. 161C is a perspective cross-sectional view of the air treatment member of FIG. 161A, taken along section line 161B-161B' of FIG. 161A, showing the driving assembly in an expanded or telescoped use position;

FIG. 161D is a perspective cross-sectional view of the air treatment member of FIG. 161A, taken along section line 161B-161B' of FIG. 161A, showing the shroud translated into a cleaned position;

FIG. 162A is a perspective view of an air treatment member, according to an embodiment, showing the driving assembly in a storage position;

FIG. 162B is a perspective cross-sectional view of the air treatment member of FIG. 162A, taken along the section line 162B-162B' of FIG. 162A;

21

FIG. 163A is a perspective view of the air treatment member of FIG. 162A, showing the driving assembly rotated into a use position;

FIG. 163B is a perspective cross-sectional view of the air treatment member of FIG. 162A, taken along the section line 162B-162B' of FIG. 162A, showing the shroud translated into a cleaned position;

FIG. 163C is a perspective cross-sectional view of the air treatment member of FIG. 162A, taken along the section line 162B-162B' of FIG. 162A, showing the shroud translated further into a cleaned position;

FIG. 163D is a perspective view of the air treatment member of FIG. 163A, and showing the driving assembly rotated into a locked position;

FIG. 164A is a perspective view of an alternate air treatment member;

FIG. 164B is a perspective cross-sectional view of the air treatment member of FIG. 164A, taken along section line 164B-164B' of FIG. 164A, showing the shroud in a storage position;

FIG. 164C is a perspective cross-sectional view of the air treatment member of FIG. 164A, taken along section line 164B-164B' of FIG. 164A, showing the shroud in a cleaned position;

FIG. 165A is a perspective cross-sectional view of another embodiment of the air treatment member of FIG. 164A, taken along section line 164B-164B' of FIG. 164A, showing the shroud in a storage position;

FIG. 165B is a perspective cross-sectional view of the embodiment of the air treatment member shown in FIG. 165A, taken along section line 164B-164B' of FIG. 164A, showing the shroud in a cleaned position;

FIG. 166A is a perspective view of an alternate air treatment member;

FIG. 166B is a cross-sectional perspective view of the air treatment member of FIG. 166A, taken along the section line 166B-166B' of FIG. 166A, showing the shroud in a storage position; and,

FIG. 166C is a perspective view of the air treatment member of FIG. 166A, and showing the shroud in a cleaned position.

DESCRIPTION OF EXAMPLE EMBODIMENTS

Numerous embodiments are described in this application, and are presented for illustrative purposes only. The described embodiments are not intended to be limiting in any sense. The invention is widely applicable to numerous embodiments, as is readily apparent from the disclosure herein. Those skilled in the art will recognize that the present invention may be practiced with modification and alteration without departing from the teachings disclosed herein. Although particular features of the present invention may be described with reference to one or more particular embodiments or figures, it should be understood that such features are not limited to usage in the one or more particular embodiments or figures with reference to which they are described.

The terms “an embodiment,” “embodiment,” “embodiments,” “the embodiment,” “the embodiments,” “one or more embodiments,” “some embodiments,” and “one embodiment” mean “one or more (but not all) embodiments of the present invention(s),” unless expressly specified otherwise.

The terms “including,” “comprising” and variations thereof mean “including but not limited to,” unless expressly specified otherwise. A listing of items does not imply that

22

any or all of the items are mutually exclusive, unless expressly specified otherwise. The terms “a,” “an” and “the” mean “one or more,” unless expressly specified otherwise.

As used herein and in the claims, two or more parts are said to be “coupled,” “connected,” “attached,” “joined,” “affixed,” or “fastened” where the parts are joined or operate together either directly or indirectly (i.e., through one or more intermediate parts), so long as a link occurs. As used herein and in the claims, two or more parts are said to be “directly coupled,” “directly connected,” “directly attached,” “directly joined,” “directly affixed,” or “directly fastened” where the parts are connected in physical contact with each other. As used herein, two or more parts are said to be “rigidly coupled,” “rigidly connected,” “rigidly attached,” “rigidly joined,” “rigidly affixed,” or “rigidly fastened” where the parts are coupled so as to move as one while maintaining a constant orientation relative to each other. None of the terms “coupled,” “connected,” “attached,” “joined,” “affixed,” and “fastened” distinguish the manner in which two or more parts are joined together.

Further, although method steps may be described (in the disclosure and/or in the claims) in a sequential order, such methods may be configured to work in alternate orders. In other words, any sequence or order of steps that may be described does not necessarily indicate a requirement that the steps be performed in that order. The steps of methods described herein may be performed in any order that is practical. Further, some steps may be performed simultaneously.

As used herein and in the claims, two elements are said to be “parallel” where those elements are parallel and spaced apart, or where those elements are collinear.

Some elements herein may be identified by a part number, which is composed of a base number followed by an alphabetical or subscript-numerical suffix (e.g. 112_a, or 112₁). Multiple elements herein may be identified by part numbers that share a base number in common and that differ by their suffixes (e.g. 112₁, 112₂, and 112₃). All elements with a common base number may be referred to collectively or generically using the base number without a suffix (e.g. 112).

General Description of a Hand Vacuum Cleaner

Referring to FIGS. 1-4, the following is a general discussion of embodiments of an apparatus 100, which provides a basis for understanding several of the features that are discussed herein. As discussed subsequently, each of the features may be used individually or in any particular combination or sub-combination in these or in other embodiments disclosed herein.

Embodiments described herein include an improved cyclonic air treatment member 116, and a surface cleaning apparatus 100 including the same. Surface cleaning apparatus 100 may be any type of surface cleaning apparatus, including for example a hand vacuum cleaner as shown in FIG. 1-2, a stick vacuum cleaner, an upright vacuum cleaner as shown in FIG. 3-4, a canister vacuum cleaner, an extractor, or a wet/dry type vacuum cleaner.

In FIGS. 1-2, surface cleaning apparatus 100 is illustrated as a hand vacuum cleaner, which may also be referred to also as a “handvac” or “hand-held vacuum cleaner”. As used herein, a hand vacuum cleaner is a vacuum cleaner that can be operated to clean a surface generally one-handedly. That is, the entire weight of the vacuum may be held by the same one hand used to direct a dirty air inlet of the vacuum cleaner with respect to a surface to be cleaned. For example, handle 104 and dirty air inlet 108 may be rigidly coupled to each other (directly or indirectly), such as being integrally formed

or separately molded and then non-removably secured together (e.g. adhesive or welding), so as to move as one while maintaining a constant orientation relative to each other. This is to be contrasted with canister and upright vacuum cleaners, whose weight is typically supported by a surface (e.g. a floor) during use. When a canister vacuum cleaner is operated, or when an upright vacuum cleaner is operated in a 'lift-away' configuration, a second hand is typically required to direct the dirty air inlet at the end of a flexible hose.

In the example of FIGS. 3-4, upright vacuum cleaner 100 is shown including an upright section 120. Handle 104 is connected to an upper end 124 of upright section 120, and a surface cleaning head 128 (also referred to as a 'floor cleaning head') is movably (e.g. pivotally) connected to a lower end 132 of upright section 120. Upright section 120 may be movable (e.g. pivotable) relative to surface cleaning head 128 between a storage position (shown) and a rearwardly reclined floor cleaning position.

Referring to FIGS. 1-4, surface cleaning apparatus 100 includes an air treatment member 116 (which may be permanently affixed to the main body or may be removable in part or in whole therefrom for emptying), a dirty air inlet 108, a clean air outlet 112, and an air flow path 136 extending between the dirty air inlet 108 and the clean air outlet 112.

Surface cleaning apparatus 100 has a front end 140, a rear end 144, an upper end (also referred to as the top) 148, and a lower end (also referred to as the bottom) 152. In the embodiment of FIGS. 1-2, dirty air inlet 108 is at a lower portion of apparatus front end 140 and clean air outlet 112 is at a rearward portion of apparatus 100 proximate apparatus rear end 144.

It will be appreciated that dirty air inlet 108 and clean air outlet 112 may be positioned in different locations of apparatus 100. For example, FIGS. 3-4 show an example in which dirty air inlet 108 is located at a lower end 156 of surface cleaning head 128, and clean air outlet 112 is located on apparatus front end 140.

Referring again to FIGS. 1-4, a suction motor 160 is provided to generate vacuum suction through air flow path 136, and is positioned within a motor housing 164. Suction motor 160 may be a fan-motor assembly including an electric motor and impeller blade(s). In the illustrated embodiment, suction motor 160 is positioned in the air flow path 136 downstream of air treatment member 116. In this configuration, suction motor 160 may be referred to as a "clean air motor". Alternatively, suction motor 160 may be positioned upstream of air treatment member 116, and referred to as a "dirty air motor".

In the illustrated embodiments, apparatus 100 is shown having two cyclonic cleaning stages 168₁ and 168₂ arranged in series with each other. It will be appreciated that air treatment member 116 may include a single cleaning stage (e.g., first cyclonic cleaning stage 168₁ or second cyclonic cleaning stage 168₂) or two or more cyclonic cleaning stages (e.g., both first and second cleaning stages 168₁ and 168₂). Each cyclonic cleaning stage 168 may include one cyclone 170 as shown, or many cyclones arranged in parallel with each other, and may include one dirt collection chamber 172 or many dirt collection chambers 172, of any suitable configuration. For example, FIG. 2 exemplifies an embodiment wherein second cyclonic cleaning stage 168₂ includes a cyclone chamber 176 having a dirt outlet 178 to an external dirt collection chamber 172. Each cyclone 170 may have its own dirt collection chamber as shown. Alternatively or in addition, two or more cyclones 170 may share a common

dirt collection chamber. Alternately, as also exemplified in FIG. 2, a cyclone 168₁ may have a dirt collection region in a portion of the cyclone chamber (e.g., a lower end of a cyclone chamber or an end of the cyclone chamber distal to the air outlet end of the cyclone chamber).

Air treatment member 116 is configured to remove particles of dirt and other debris from the air flow. In the illustrated example, air treatment member 116 includes a cyclone assembly (also referred to as a "cyclone bin assembly") having at least a first cyclonic cleaning stage 168₁ with a cyclone 170 and a dirt collection chamber 172 (also referred to as a "dirt collection region", "dirt collection bin", "dirt bin", or "dirt chamber"). Cyclone 170 has a cyclone chamber 176. As exemplified, dirt collection chamber 172 may be external to the cyclone chamber 176 (i.e. dirt collection chamber 172 may have a discrete volume from that of cyclone chamber 176), or dirt collection chamber 172 may be a dirt collection region located partially or entirely within a volume of cyclone chamber 176.

FIG. 118B exemplifies an embodiment of a dirt collection chamber 172 located exterior to the volume of the cyclone chamber 176. In the exemplified embodiment, a deflector or arrestor plate 810 is positioned proximal one end of the cyclone chamber 176 (e.g., a second cyclone end 244, opposite the cyclone end having the cyclone air inlet 204), and is spaced from the cyclone end 244. The dirt chamber 172 defines the area between the cyclone end 244, and the arrestor plate 810. In the exemplified embodiment, the dirt chamber is in communication with the cyclone chamber via a dirt outlet 178 that is formed as a slot in the cyclone sidewall 236. Other dirt outlets known in the art may be used. Optionally, as exemplified, the arrestor plate 810 can be supported, e.g., by a support member 812, that is mounted to an openable door 352 (e.g., defined by the second cyclone end 244). As explained in further detail herein, door 352 can be opened to empty the majority of loose dirt and debris contained in cyclone chamber 176 as well as in the dirt chamber 172. As exemplified, by supporting the arrestor plate 810 on the door 352, this can allow the arrestor plate 810 to open concurrently with the openable door 352. Alternatively, in other embodiment, the arrestor plate 810 may be mounted to the sidewall 236 (or other portion of the surface cleaning apparatus 100). It will be appreciated that, in other embodiments, cyclone 170 and dirt collection chamber 172 may be of any other configuration suitable for separating dirt from an air stream and collecting the separated dirt respectively.

Referring to FIGS. 2 and 4, surface cleaning apparatus 100 may include a pre-motor filter 180 provided in the air flow path 136 downstream of air treatment member 116 and upstream of suction motor 160. Pre-motor filter 180 may be formed from any suitable physical, porous filter media. For example, pre-motor filter 180 may be one or more of a foam filter, felt filter, HEPA filter, or other physical filter media. In some embodiments, pre-motor filter 180 may include an electrostatic filter, or the like. As shown, pre-motor filter 180 may be located in a pre-motor filter housing 184 that is external to the air treatment member 116.

As shown in FIG. 2, dirty air inlet 108 may be the inlet end 188 of an air inlet conduit 192. Optionally, inlet end 188 of air inlet conduit 192 can be used as a nozzle to directly clean a surface. Alternatively, or in addition to functioning as a nozzle, air inlet conduit 192 may be connected (e.g. directly connected) to the downstream end of any suitable accessory tool such as a rigid air flow conduit (e.g., an above floor cleaning wand), a crevice tool, a mini brush, and the

like. As shown, dirty air inlet **108** may be positioned forward of air treatment member **116**, although this need not be the case.

In the embodiments of FIGS. **2** and **4**, the air treatment member **116** comprises one or more cyclonic cleaning stages **168**, the air treatment air inlet is a cyclone air inlet **196** (e.g. a tangential air inlet of first stage **168**₁), and the air treatment member air outlet is a cyclone air outlet **204** (e.g. of second stage **168**₂). The cyclone air inlet **196** may have a length (or height) **196a** in the direction of the cyclone axis **232** (see e.g., FIGS. **45-47**). In operation, after activating suction motor **160**, dirty air enters apparatus **100** through dirty air inlet **108** and is directed along air inlet conduit **192** to the cyclone air inlet **196** of first stage **168**₁. As shown, cyclone air inlet **196** may direct the dirty air flow to enter cyclone chamber **176** in a tangential direction so as to promote cyclonic action. Dirt particles and other debris may be disentrained (i.e. separated) from the dirty air flow as the dirty air flow travels through first cyclonic stage **168**₁—from the respective cyclone air inlet **196** to cyclone air outlet **204**. The disentrained dirt particles and debris may collect in dirt collection chamber or region **172** of first stage **168**₁, where the dirt particles and debris may be stored until the dirt collection region is emptied. From cyclone air outlet **204**, the air may flow downstream through second stage **168**₂—from the respective cyclone air inlet(s) **196** to cyclone air outlet **204**, whereby separated dirt particles may discharge through dirt outlet **178** into dirt collection chamber **172**.

Air exiting a cyclone chamber **176** may pass through an outlet passage **208** located upstream of the cyclone air outlet **204**. Cyclone chamber outlet passage **208** may also act as a vortex finder to promote cyclonic flow within cyclone chamber **176**. In some embodiments, cyclone outlet passage **208** may include a porous member, such as a screen or shroud **212** (e.g. a fine mesh screen) in the air flow path **136** to remove large dirt particles and debris, such as hair, remaining in the exiting air flow. The screen or shroud **212** may have any configurations known in the art. For example, the shroud **212** may be cylindrical (e.g., FIGS. **1-31**, **49-50**), conical or frusto-conical (see e.g., FIGS. **45-48**). The shroud **212** may also have any suitable axial length **502**. For example, the axial length **502** of the shroud **212** may be approximately $\frac{1}{5}^{th}$ of the cyclone height **320** (see e.g., FIG. **46**), $\frac{2}{5}^{th}$ of the cyclone height (e.g., FIG. **47**), $\frac{3}{5}^{th}$ of the cyclone height (e.g., FIG. **45**), or $\frac{4}{5}^{th}$ of the cyclone height. In other cases, the axial height **502** of the shroud **212** may be expressed as a proportion of the cyclone inlet height **196a**. For example, the axial height **502** of the shroud **212** may be in a range of 0.25-40, 0.50-20, 0.50-20, 1-5, or 1.5 to 3 times the cyclone inlet height **196a**.

From cyclone air outlet **204** of second stage **168**₂, the air flow may be directed into pre-motor filter housing **184** at an upstream side **216** of pre-motor filter **180**. The air flow may pass through pre-motor filter **180**, and then exit through pre-motor filter housing air outlet **220** into motor housing **164**. At motor housing **164**, the clean air flow may be drawn into suction motor **160** and then discharged from apparatus **100** through clean air outlet **112**. Prior to exiting the clean air outlet **112**, the treated air may pass through a post-motor filter **224**, which may include one or more layers of filter media.

Power may be supplied to suction motor **160** and other electrical components of apparatus **100** from an onboard energy storage member **228** (FIG. **2**) which may include, for example, one or more batteries or other energy storage device. The energy storage member **228** may be operable in either a low power mode or a high power mode. In the low

power mode, the energy storage member **228** may operate the suction motor **160** at a low power level. For example, the low power mode may be used to extend the run time of the energy storage member **228**. In contrast, in the high power mode, the energy storage member **228** may operate the suction motor **160** at a high power level. In various cases, the high power mode may be used to increase the cleaning performance of the apparatus **100**, which may result in a shorter run time. In the example of FIG. **2**, apparatus **100** includes a battery pack **228**. Battery pack **228** may be permanently connected to apparatus **100** and rechargeable in-situ, or removable from apparatus **100**. In the example shown, battery pack **228** is located below handle **104**. Alternatively or in addition to battery pack **228**, power may be supplied to apparatus **100** by an electrical cord (not shown) connected to apparatus **100** that can be electrically connected to mains power by at a standard wall electrical outlet.

Cyclone with an Openable Sidewall

The following is a discussion of a cyclone with an openable sidewall, which may be used by itself or with one or more of the moveable screen, the dual end walls, the medial cyclone air inlet, the exterior dirt collection chamber the axially extending member (vertically extending screen), and the dirt ejection mechanism.

A cyclone separates dirt and debris from an air stream that is moved through a cyclone chamber. Separated dirt and debris may be collected in a dirt collection chamber that is external to the cyclone chamber (e.g., via a cyclone chamber dirt outlet) or separated dirt and debris may be collected in a dirt collection region that is interior of the cyclone as exemplified by cyclone **168**₁ of FIG. **2**. A cyclone may be emptyable through an openable end door. However, some separated dirt and debris may collect on other interior surfaces of the cyclone, which may not be easily removed through the openable end door. For example, dirt and debris may accumulate or become entangled on the screen of a vortex finder of the cyclone. If not removed, this dirt and debris will occupy space inside the cyclone thereby reducing the volume available for cyclonic flow, which may reduce the dirt separation efficiency of the air treatment member. According to this aspect, a cyclone chamber is openable other than by merely opening the end of the cyclone chamber.

FIGS. **5-6** exemplify a cyclone, which may be referred to as a cyclonic air treatment member **116**, in accordance with an embodiment. As shown, cyclone bin assembly includes a cyclone **170** with a cyclone chamber **176**, a cyclone air inlet **196**, a cyclone air outlet **204**, and a cyclone axis of rotation **232** (also referred to as cyclone axis **232**). The cyclone chamber **176** has a cyclone chamber sidewall **236** that extends axially between the chamber first end **240** and the chamber second end **244**. In the exemplified embodiment, the cyclone **170** is configured as a generally vertical, upright cyclone, wherein the cyclone air outlet **204** is positioned at the first cyclone end **240**, and the first cyclone end **240** is positioned above the second cyclone end **244**. In other embodiments, the cyclone **170** can be configured as a generally vertical, inverted cyclone, wherein the cyclone air outlet **204** is positioned at the second cyclone end **244**, with the first cyclone end **240** is positioned above the second cyclone end **244** (see for example FIGS. **111-113**). Other cyclone designs known in the art may also be used.

As exemplified, in accordance with this aspect, cyclone chamber sidewall **236** comprises a first portion **248** and a second portion **252** which are moveably mounted with respect to each other so as to provide an area to access the

interior of the cyclone chamber that is larger than the cross sectional area of the end wall of the cyclone at second end 244. As exemplified, first portion 248 is moveable relative to sidewall second portion 252 between a closed position (FIG. 1) and an open position (FIGS. 5-6). In the closed position (FIG. 1), sidewall first portion 248 may meet (e.g. seal to) sidewall second portion 252 at first and second junctures 254₁ and 254₂. This closes cyclone chamber 176 so that cyclone 170 can function to separate dirt and debris from air flow moving through cyclone chamber 176. In the open position, sidewall first portion 248 is at least partially separated (e.g. spaced apart from) sidewall second portion 252 to define opening(s) 256 into cyclone chamber 176. Dirt and debris collected, accumulated, or tangled within cyclone chamber 176 can be easily removed through cyclone chamber opening(s) 256. As exemplified in FIGS. 124A-124C, in some embodiments, the cyclone air inlet 196 may be provided along the sidewall first portion 248 (e.g., an openable bottom wall or an openable bottom portion as exemplified), and accordingly, may be moveable with the sidewall portion 248 to the open position (see for example FIG. 124C).

Referring to FIGS. 1, 5, and 6, each juncture 254 may be defined where an edge of sidewall first portion 248 meets an edge of sidewall second portion 252 in the closed position. As shown, first portion 248 may include first edge 260₁, second portion 252 may include first edge 260₂, and edges 260 may abut each other in the closed position to define first juncture 254₁. Similarly, first portion 248 may include second edge 264₁, second portion 252 may include second edge 264₂, and edges 264 may abut each other in the closed position to define second juncture 254₂. In the open position (FIGS. 5-6), both edges 260, 264 may be moved apart to create an opening 256 into cyclone chamber 176 for emptying dirt and debris contained inside or, as exemplified in FIG. 14, one of the edges 260, 264 may be moved apart to create an opening 256 into cyclone chamber 176.

Edges 260, 264 may be the plastic edges of the cyclone chamber side wall that abut each other or, alternately, a gasket or the like may be provided to assist in providing a seal along the juncture. The edges may be planar or an alternate shape to assist in providing a seal, such as tongue and groove.

One or both of junctures 254 may extend at a (non-zero) angle 270 to a plane 268 that is transverse to cyclone axis 232. For example, as exemplified in FIG. 5, the juncture may extend axially (perpendicular to plane 268) or at an angle between 0° and 90° exclusive, as exemplified in FIGS. 10 and 117-120.

A sidewall first portion 248 that opens along junctures 254 angled in this way can provide an opening 256 into cyclone chamber 176, which has an axial dimension and which has a greater cross-sectional area than opening the end wall of a cyclone, thereby providing better access to dirt and debris contained inside cyclone chamber 176. In contrast, an cyclonic air treatment member having only an end wall door, may require the user to reach their hand and arm through the open end wall door into the cyclone chamber to clear dirt and debris (e.g. accumulated or tangled on a vortex finder), which may be unpleasant for the user.

Sidewall first portion 248 may be moveably mounted with respect to sidewall second portion 252, sidewall second portion 252 may be moveably mounted with respect to sidewall first portion 248 or both sidewall portions 248, 252 may be moveable with respect to each other.

In the illustrated example, junctures 254₁ and 254₂ extend axially parallel to cyclone axis 232. When sidewall first portion 248 is moved relative to sidewall second portion 252

to separate sidewall first portion 248 from sidewall second portion 252 along junctures 254, the resulting cyclone chamber opening 256 extends axially (i.e. along an axial length of cyclone chamber 176). An advantage of this design is that the axial dimension of cyclone chamber opening 256 provides a large opening 256 and thereby improves user-access to dirt and debris that may be located throughout cyclone chamber 176. For example, when sidewall first portion 248 is moved to the open position, cyclone chamber opening 256 may allow user access to debris at both cyclone chamber ends 240, 244 without having to unpleasantly reach a length of their arm into the dirty and dusty cyclone chamber 176.

Sidewall first portion 248 may be movably mounted with respect to sidewall second portion 252 in any manner that allows sidewall first portion 248 to move between a closed position (FIG. 1) and an open position (FIGS. 5-6). For example, sidewall first portion 248 may be rotatable (e.g., as exemplified in FIGS. 27-30), pivotable (as exemplified in FIGS. 5 and 14), translatable (as exemplified in FIG. 31), or any combination thereof, relative to sidewall second portion 252.

Referring to FIGS. 5-6, sidewall first portion 248 is pivotable relative to sidewall second portion 252. As exemplified, sidewall first portion 248 is connected to cyclone 170 by a hinge 272 that defines a rotation axis 276 (sometimes referred to as a 'pivot axis').

Rotation axis 276 may have any position suitable to allow sidewall first portion 248 to pivot relative to sidewall second portion 252 between the closed and open positions. For example, rotation axis 276 may be positioned external to cyclone chamber 176 as shown, or rotation axis 276 may extend through cyclone chamber 176. As shown, positioning rotation axis 276 external cyclone chamber 176 can allow hinge 272 to be located outside of cyclone chamber 176, such that hinge 272 does not interfere with air flow through cyclone chamber 176 and does not occupy space within cyclone chamber 176. Rotation axis 276 may also be located at any location along the axial length of the cyclone. For example, axis 276 may be located at one end of the cyclone chamber as exemplified in FIG. 5, or at an intermediate location along the length of the cyclone sidewall.

Rotation axis 276 may have any orientation suitable to allow sidewall first portion 248 to pivot relative to sidewall second portion 252 between the closed and open positions. For example, rotation axis 276 may be oriented transverse to cyclone axis 232 (see, e.g., FIG. 5), or rotation axis 276 may extend axially (e.g. parallel to cyclone axis 232, see e.g., FIG. 14). An advantage of the design of FIG. 5 is that the end of sidewall first portion 248 distal to axis 276 may rotate farther away from sidewall second portion 252 in the open position per degree of rotation. Accordingly, rotation axis 276 positioned and oriented as shown may provide greater user access to a lower end of the interior of cyclone chamber 176 to remove the contained dirt and debris.

Hinge 272 may be any device suitable to (directly or indirectly) connect sidewall first portion 248 to sidewall second portion 252 and allow sidewall first portion 248 to rotate relative to sidewall second portion 252 between the closed and open positions. For example, hinge 272 may have a multi-part design as shown, or hinge 272 may be a single-part living hinge. As compared to a single-part living hinge 272, a multi-part hinge 272 typically provides greater strength and working life (e.g. number of rotations before failure). A single-part living hinge 272 allows chamber first end 240 to be integrally formed with cyclone 170, which

reduces the number of components, which in turn can reduce manufacturing and assembly costs.

Referring to FIGS. 1, 5, and 6, a cyclone chamber opening 256 may have an area 280 that is larger than an opening provided by an openable door at cyclone end wall 244. For example, opening area 280 may be greater than a cross-sectional area 284 measured on a plane 268 that is perpendicular to cyclone axis 232. The comparatively larger opening area 280 provides greater user access to remove dirt and debris from an interior of cyclone chamber 176 as compared to an end wall door. In some embodiments, opening area 280 may be at least 120% (e.g. 120% to 500%) of chamber cross-sectional area 284. In the illustrated example, the opening area 280 of each cyclone chamber opening 256 is at least 200% of chamber cross-sectional area 284.

Referring to FIGS. 5-6, one or more parts of cyclone chamber 176 or dirt collection chamber 172 may be movable with sidewall first portion 248 to the open position. This can allow those part(s) to be reoriented in the open position in a way that provides greater user access to dirt and debris collected on those part(s), and/or that allows dirt and debris collected on those part(s) to fall out of chamber(s) 172, 176 by gravity (e.g. into a waste bin below). In general, the more dirt and debris that falls out of chamber(s) 172, 176 by gravity alone, results in less unpleasant user-contact with dirt and debris to clean out chamber(s) 172, 176.

In the illustrated example, cyclone chamber second end wall 244 is connected to sidewall first portion 248 so that cyclone chamber second end wall 244 rotates with sidewall first portion 248 to the open position. This tilts the surface of cyclone chamber second end wall 244 towards an axial (e.g. vertical) orientation, which can allow dirt and debris collected on cyclone chamber second end wall 244 to fall out of chambers 172, 176 by gravity. This also removes cyclone chamber second end wall 244 from sidewall second portion 252 so that dirt and debris associated with sidewall second portion 252 can fall out of chambers 172, 176 by gravity instead of forming a pile on cyclone chamber second end wall 244 at the bottom end.

In an alternative embodiment, cyclone chamber second end wall 244 may remain with sidewall second portion 252 when sidewall first portion 248 is moved to the open position.

In any embodiment, cyclone chamber second end wall 244 may be openable, e.g., it may be pivotally mounted to one of the sidewall portions 248, 252.

As mentioned previously, FIGS. 10-11 and 117-120 exemplify an embodiment wherein the juncture extends at an angle between 0° and 90° exclusive to transverse plane 268. The sidewall portions 248, 252 meet along a sidewall juncture 254 in the closed position (FIGS. 10, 117 and 119) and may be pivoted away from each other to the open position (FIGS. 11, 118 and 120). In the open position, edges 260 of sidewall portions 248, 252 are spaced apart, and each sidewall portion 248, 252 has a cyclone chamber opening 256.

In accordance with this embodiment, sidewall juncture 254 forms (non-zero) angles to both cyclone axis 232 and transverse plane 268. Accordingly, sidewall juncture 254 has an axial extent or dimension that creates comparatively large area chamber openings 256 in the open position, but that does not extend axially parallel to cyclone axis 232. As compared to a sidewall juncture that is parallel to cyclone axis 232, the illustrated sidewall juncture 254 has a shorter linear length, which may result in less cost, less complexity, and greater reliability in maintaining an air tight seal along sidewall juncture 254 in the closed position.

Sidewall juncture 254 may be located anywhere between cyclone chamber ends 240, 244. Preferably, sidewall juncture 254 is spaced apart from cyclone chamber end 240, 244. This positions sidewall juncture 254 more centrally between cyclone chamber ends 240, 244 whereby in the open position, the maximum distance from cyclone chamber openings 256 to an interior surface of cyclone chamber 176 is reduced. For example, sidewall juncture 254 may be spaced from cyclone chamber first end 240 by a distance 336, spaced from cyclone chamber second end 244 by a distance 340, and each of distances 336 and 340 may be at least 10%, 20%, 30%, 40% or 50% (e.g. 10% to 50%, 20% to 40%) of cyclone chamber height 320.

Still referring to FIGS. 10-11, sidewall juncture 254 has a first end 344 having a first axial position, a second end 348 having a second axial position, and some or all of screen 212 has an axial position located between the axial positions of the sidewall juncture ends 344, 348. As shown in FIG. 11, this can allow some or all of screen 212 to extend out of a cyclone chamber opening 256 when the cyclone is in the open position, which can provide easy user-access to surfaces of screen 212 for cleaning.

As with the embodiment of FIGS. 5 and 6, cyclone second end 244 may be a movable (e.g. pivotable, translatable, and/or removable) end wall 352. As exemplified, cyclone second end 244 includes an openable door 352. Door 352 can be opened to empty the majority of loose dirt and debris contained in cyclone chamber 176. This can mitigate loose dirt and debris spilling uncontrollably when moving sidewall first portion 248 to the open position. An openable door 352 may be provided at one or both ends of the cyclone and, e.g., may be pivotally connected to one or both of sidewall portions 248, 252. In the illustrated example, openable door 352 is pivotally connected by a hinge 356 to sidewall first portion 248, and a latch 360 is provided to removably secure openable door 352 closed.

As mentioned previously, FIG. 14 exemplifies an axially extending pivot axis 276. An advantage of this design is that in the open position, each sidewall portion is opened and the cyclone chamber openings 256 may extend the full axial length of cyclone chamber 176. This provides easy user-access to dirt and debris located anywhere inside of cyclone chamber 176. It will be appreciated that the hinge may extend along only part of the axial length of the sidewall.

Sidewall portions 248, 252 can have any circumferential angular extent. For example, sidewall first portion 248 may have a circumferential angular extent of between 25° and 335°. More preferably, the circumferential angular extent may be more balanced as between sidewall portions 248, 252 so that each sidewall portion 248, 252 has a conveniently large cyclone chamber opening 256 in the open position. For example, the circumferential angular extent of sidewall first portion 248 may be between 135° and 225°. In the illustrated example, both sidewall portions 248 have an angular extent of about 180°. This provides each sidewall portion 248, 252 with a similarly large cyclone chamber opening 256.

Sidewall first portion 248 may be pivotally mounted about an axial rotation axis 276. This allows cyclone 170 to have a relatively smaller footprint when in the open position so that all of cyclone 170 can be underlied by a standard sized waste bin that is collecting dirt and debris falling from cyclone 170. In the illustrated example, rotation axis 276 is parallel to cyclone axis 232. In some embodiments, sidewall hinge 272 is a piano hinge that is provided on an exterior of the sidewall and extends axially along sidewall portions 248, 252.

Hinge 272 may extend from one end of the cyclone chamber to the other end of the cyclone chamber as exemplified in FIG. 14, or it may extend along only part of the axial length. For example, it may extend from one end of the cyclone chamber towards the other end or it may extend along only part of an intermediate section of the sidewall between the first and second axially opposed cyclone ends. In such a case, the sidewall portion that opens may define a door having upper and lower ends that mate with the other sidewall portion along upper and lower edges that extend around a portion of the perimeter of the sidewall.

FIGS. 19-21 exemplify an alternate embodiment wherein the axis 276 extends in the direction of the cyclone axis of rotation 232 but wherein the axis 276 extends through the cyclone chamber. Optionally, as exemplified, rotation axis 276 is coaxial or collinear with cyclone axis 232. Sidewall first portion 248 is rotatable about axis 276 relative to sidewall second portion 252 from a closed position to an open position (FIG. 20) in which sidewall portions 248, 252 are partially or completely nested with one another. For example, sidewall first portion 248 may nest within sidewall second portion 252 as shown, or vice versa. An advantage of this design is that it may provide even greater exposure to interior surfaces of cyclone chamber 176. Further, this design may reduce the time and effort required to clean out cyclone chamber 176 because the act of nesting one sidewall portion into the other may empty the outer sidewall portion into the inner sidewall portion or out of cyclone chamber 176. Thus, the user may have only to attend to emptying dirt and debris associated with the inner sidewall portion. Also, an open position in which sidewall portions 248, 252 are nested may reduce the footprint of cyclone chamber 176, which may make it possible or easier to empty cyclone chamber 176 into a waste bin below without spilling.

Each sidewall portion 248, 252 is exemplified as an axial cylindrical segment. In the example shown, each sidewall portion 248, 252 has a circumferential angular extent of approximately 180°. This allows the sidewall portions 248, 252 to completely nest with each other in the open position (FIG. 20). In other embodiments, the circumferential angular extent of each sidewall portion 248, 252 may differ from 180°. For example, the inner sidewall portion 248 may have an angular extent of greater than or less than 180°.

It will be appreciated that cyclone chamber sidewall 236 may include any number of sidewall portions, which are mounted so that they can move relative to each other between a closed position and an open position. Accordingly, while FIGS. 20-21 show an embodiment in which cyclone chamber sidewall 236 includes two sidewall portion 248, 252 that are each an axial cylindrical segment, and which are nested in the open position (FIG. 21), a larger number of segments may be provided. This may permit cyclone chamber 176 to have an open position that provides even greater user-access to the interior volume, surfaces, and contents of cyclone chamber 176. In turn, this may make it easier for the user to clean cyclone chamber 176 of dirt and debris.

For example, FIGS. 27-30 show an example including three sidewall portions 248, 252, 388, each of which is an axial cylindrical segment, and which are nested in the open position (FIG. 30). Sidewall portions 248, 252, 388 may have the same circumferential angular extent as shown (e.g. approximately 120°), or one or more (or all) of sidewall portions 248, 252, 388 may have a different circumferential angular extent as compared to each other sidewall portion 248, 252, 388. As shown, the larger number of sidewall portions 248, 252, 388 may result in a larger portion of

cyclone outlet passage 208 being located outside of cyclone chamber 176 when in the open position, even where cyclone outlet passage 208 is not movably mounted (i.e. where cyclone outlet passage 208 is rigidly connected to cyclone 170). In the illustrated example, cyclone chamber 176 spans approximately 120° in the open position such that approximately 240° (i.e. about two thirds) of cyclone outlet passage 208 is positioned outside of cyclone chamber 176.

As mentioned previously, FIGS. 31-32 exemplify an embodiment in which sidewall first portion 248 is axially translatable to the open position as shown. Depending on the manner in which cyclonic air treatment member 116 is connected to the surface cleaning apparatus, this design may prevent cyclone chamber 176 from being opened while connected to the surface cleaning apparatus. As shown, sidewall portions 248, 252 may meet (e.g. be sealed) at first and second junctures 254. First juncture 254₁ may be parallel to second juncture 254₂ and angularly spaced around cyclone chamber 176 from second juncture 254₂. In the example shown, both junctures 254 extend axially (e.g. parallel to cyclone axis 232).

FIG. 34 exemplifies an embodiment in which sidewall first portion 248 is an axial cylindrical segment, which is pivotally mounted to cyclone 170 so that it can rotate about a rotation axis 276, which is transverse (e.g. perpendicular) to cyclone axis 232.

Moveable Screen

The following is a discussion of a moveable screen, which may be used by itself or with one or more of the cyclone with an openable sidewall, the dual end walls, the medial cyclone air inlet, the exterior dirt collection chamber the axially extending member (vertically extending screen), and the dirt ejection mechanism.

As exemplified in FIGS. 5-6, cyclone 170 may include a cyclone outlet passage (e.g. vortex finder) 208 including a porous member, which may be referred to as a screen or shroud 212, that may collect larger dirt particles and debris (e.g. hair) which remains entrained in the air flow exiting the cyclone 170. When sidewall first portion 248 is in an open position, a portion of screen 212 may remain in close proximity to one of sidewall portions 248, 252, and that proximity may make user access to clean that portion of screen 212 difficult (e.g. the clearance may be too small for a user's fingers). In some embodiments, cyclone outlet passage 208 may be movably mounted with respect to one or both of the sidewall portions 248, 252. This can allow the user better access to clean surfaces of screen 212.

In accordance with this aspect, the cyclone outlet passage (e.g. vortex finder) 208 is moveable so as to permit easier access to more of the perimeter of the outlet passage and, optionally, all of the perimeter of the outlet passage.

Cyclone outlet passage 208 may be movably mounted with respect to one or both sidewall portions 248, 252 in any manner suitable to improve user-access to some or all of the outer surface of screen 212. For example, cyclone outlet passage 208 may be removable from cyclone 170, or cyclone outlet passage 208 may be rotatable, translatable, or both while remaining connected to cyclone 170.

As exemplified in FIGS. 5-6 and 7-9, cyclone outlet passage 208 is movably mounted with respect to both sidewall portions 248, 252. As shown, when sidewall first portion 248 is moved to the open position, cyclone outlet passage 208 is movable away from sidewall portion 252, concurrently, or subsequently, outlet passage 208 may be moved away from sidewall portion 248. This increases the

clearances between screen **212** and both sidewall portions **248**, **252**, which can greatly improve user-access to clean surfaces of screen **212**.

In the illustrated example, cyclone outlet passage **208** is pivotable about a rotation axis **288** relative to sidewall portion **248**. As shown, this allows cyclone outlet passage **208** to rotate away from sidewall portion **248** when in the open position. Accordingly, when the sidewall portions are pivoted open and the screen is pivoted to the open position shown in FIG. 6, clearances **292**, **296** between screen **212** and sidewall portions **248**, **252** respectively increase to provide greater user-access to the outer surface of screen **212** for cleaning. See also FIG. 33.

In the example shown, cyclone outlet passage **208** is pivotally connected to sidewall first portion **248**. Alternatively, cyclone outlet passage **208** may be pivotally connected to sidewall second portion **252** or to another portion of cyclone **170**.

FIG. 12 exemplifies an alternate embodiment wherein cyclone outlet passage **208**, including screen **212**, is removable from cyclone **170** after sidewall first portion **248** is moved to the open position. This can allow cyclone outlet passage **208** to be most easily cleaned, and optionally replaced if it is a consumable item or damaged.

FIG. 13 exemplifies an embodiment in which cyclone outlet passage **208**, including screen **212**, is translatable relative to sidewall portions **248**, **252**. As shown, cyclone outlet passage **208** may be translatablely connected to one of the sidewall portions, e.g., sidewall portion **252**, whereby cyclone outlet passage **208** can move along track **364** through cyclone chamber opening **256**. This moves screen **212** out of cyclone chamber **176** so that it can be easily cleaned of dirt and debris by the user.

As exemplified in FIGS. 14-16, cyclone outlet passage **208** (including screen **212**) may be pivotable about an axial screen rotation axis **372**. As shown, this design allows cyclone outlet passage **208** to be rotated out of the cyclone chamber to provide easy user-access to surfaces of screen **212** for cleaning. In this example, screen rotation axis **372** is shown as parallel to cyclone axis **232**. In other embodiments, screen rotation axis **372** may be oriented at a (non-zero) angle to cyclone axis **232**. A similar design is useable in the embodiment of FIG. 26.

Dual End Walls

The following is a discussion of dual end walls, which may be used by itself or with one or more of the cyclone with an openable sidewall, the moveable screen, the medial cyclone air inlet, the exterior dirt collection chamber the axially extending member (vertically extending screen), and the dirt ejection mechanism.

An advantage of this design is that each openable sidewall portion may have part of the end wall **244**. This can facilitate sealing the cyclone chamber when the sidewall portions are in the closed position.

As exemplified in FIG. 14, half of the end wall **244** may be fixedly mounted to each sidewall portion **248**, **252**.

Alternately, as exemplified in FIGS. 16-17, each end wall portion may be openable. As exemplified therein, cyclone chamber **176** may include an openable end wall **352** at chamber second end **244**. As shown, openable end wall **352** may include a first wall portion **376** movably (e.g. pivotally) connected to sidewall first portion **248** and a second wall portion **380** movably (e.g. pivotally) connected to sidewall second portion **252** as shown. An advantage of this design is that upon opening end wall **352** to empty dirt and debris from cyclone chamber **176** into a waste bin below, the end wall portions **376**, **380** may tend to funnel the falling dirt and

debris into a waste bin below. This may mitigate the dirt and debris spilling laterally outside of the waste bin upon opening end wall **352**.

FIGS. 19-21 exemplify the use of two end wall segments in a rotational opening design. As shown, in the open position (FIG. 20), end wall portion **376** may overlie end wall portion **380**. As compared with an end wall **352** that remains whole (e.g. if the design of end wall **352** of FIG. 18 were used and end wall **352** was mounted in a fixed position to a sidewall portion), this design may reduce the effective surface area of end wall **352** in the open position so that dirt and debris can fall out of cyclone chamber **176** more easily. Furthermore, this design may make cleaning cyclone chamber **176** easier in that the act of moving wall second portion **380** under wall first portion **376** may automatically push dirt and debris collected on wall second portion **380** out of cyclone chamber **176**.

FIG. 24 exemplifies the use of two end wall segments in a rotational opening design wherein door portions **376**, **380** are separately openable.

Medial Cyclone Air Inlet

The following is a discussion of a cyclone with a medial cyclone air inlet, which may be used by itself or with one or more of the cyclone with an openable sidewall, the moveable screen, the dual end walls, the exterior dirt collection chamber the axially extending member (vertically extending screen), and the dirt ejection mechanism.

Optionally, the cyclone air inlet may be located in a medial position between the first cyclone end and the second cyclone end, and may be provided on the cyclone sidewall (e.g., the cyclone inlet may be a tangential air inlet terminating at a port in the sidewall). Accordingly, dirty air may enter the medial inlet, and may flow inside of the cyclone chamber in two directions: (a) axially toward the first cyclone end, and (b) axially toward the second cyclone end. An advantage of this configuration is that cyclonic action is promoted in both the upper and lower portions of the cyclone unit, which may tend to improve the dirt separation efficiency of the cyclone unit.

Optionally, a flange may extend at least part way around the inner surface of the cyclone sidewall to overlie or underlie the medial cyclone air inlet. In various cases, the flange may control (e.g., limit) the volume of air flowing axially (e.g., upwardly or downwardly) if the first cyclone end is positioned over the second cyclone end) inside of the cyclone chamber. The flange may be placed at an axial end of the cyclone inlet, or it may be spaced therefrom.

In the drawings, the cyclone is oriented with the first cyclone end positioned over the second cyclone end. Accordingly, the cyclone is oriented vertically and the portions of the cyclone may consequentially be referred to as upward or above or downward or below and the flow of the air may consequentially be referred to as upwardly or downwardly. It will be appreciated that the cyclone may be oriented, and used, in various orientations.

Referring now to FIG. 38, as exemplified, the first cyclone end **240** may be positioned over the second cyclone end **244**. In this configuration, the axial height **320** of the cyclone unit **170** may be divided into three portions: an upper portion **320a**, a lower portion **320b**, and a medial portion **320c** located between the upper and lower portions **320a**, **320b**.

The upper and lower portions **320a**, **320b** may comprise any relative proportions of the axial height **320** of the cyclone unit **170**. For example, each of the upper and lower portions may comprise 10%, 15%, 20%, or 25% of the total axial height **320** of the cyclone unit **170**. Accordingly, the

medial portion may comprise 80%, 70%, 60% or 50% of the remaining axial height **320** of the cyclone unit **170**, respectively.

As exemplified in FIGS. **36** to **41**, the cyclone air inlet **196** may be located laterally (e.g., it may be a tangential air inlet) on the side wall **236** of the medial portion **320c**. Accordingly as best exemplified by FIG. **38**, air entering the cyclone chamber **176** via the medial inlet **196** flows (e.g., travels) in two directions: (a) axially upwardly toward the first cyclone end **240**, and (b) axially downwardly toward the second cyclone end **244**. In this manner, rotational upflow cyclone action (or inverted cyclone action) is induced in the upper cyclone portion **320a**, and rotational down flow cyclone action is induced in the lower cyclone portion **320b**. In various cases, this may help to increase the dirt separation efficiency of the cyclone unit. For example, finer or less dense particles of dust and dirt may travel upwardly into the upper cyclone portion **320a** to be ejected into the external dirt chamber **172b**, while coarser or denser particles of dust and dirt may travel downwardly into the lower cyclone portion **320b** to aggregate inside of the lower end of the cyclone chamber, e.g., an internal dirt collection chamber **172a**.

The cyclone air inlet, which in this aspect may be referred to as a medial air inlet or medial inlet **196**, may be provided at any location within the medial portion **320c**. For instance, the medial inlet **196** may be provided in an axially upper portion of the medial portion **320c** (see e.g., FIG. **38**), a middle portion of the medial portion **320c** (e.g., FIG. **80**), or a lower portion of the medial portion **320c** (see e.g., FIG. **45**).

Optionally, the medial inlet **196** is located below a location at which air may exit the cyclone chamber. Accordingly, the upper end of the medial inlet **196** may be positioned below the cyclone outlet passage **208** and/or the shroud **212**, or at least adjacent an axially inward end **212a** of the shroud **212**. If the axial inward end **212a** is solid (e.g., i.e., no air flow passes therethrough), then the medial inlet **196** may be positioned adjacent or below the porous portion of the screen **212**.

It will be appreciated that while only a single medial inlet **196** has been illustrated in the exemplified embodiments, in other embodiments, more than one medial inlet **196** may be provided inside of the cyclone chamber **170**. For example, two or more medial inlets **196** may be vertically spaced along the cyclone sidewall **236**. Alternatively, or in addition, two or more medial inlets **196** may be spaced along the perimeter of the cyclone sidewall **236**.

Optionally, as best exemplified in FIGS. **39**, **42** and **44**, a flange **392** may extend around at least a portion of the inner surface of the cyclone sidewall **236**, and may extend inwardly, and optionally radially inwardly into the cyclone chamber **176**. The flange **392** may be formed of any suitable material, including resilient material. For example, the flange may be made of the same material as the cyclone sidewall and may be molded as part thereof.

In the exemplified embodiments, the flange **392** is positioned axially above the medial inlet **196**, and preferably, axially below the cyclone outlet **208** and/or the shroud **212**. Without being limited by theory, in this configuration, the flange **392** blocks or inhibits some of the upward air flow into the cyclone chamber **196** from the medial inlet **196**. In other words, the flange **392** may control the volume of air entering the upper cyclone portion **320a**. An advantage of this configuration is that, by limiting the upward air flow, the flange **392** may assist in a larger portion of the air travelling into the lower cyclone portion **320b** and/or block larger dirt

particles from being drawn upwardly into the upper portion **320a**. Accordingly, the flange **392** may increase the dirt separation efficiency of the cyclone unit **170**.

Alternatively, or in addition, a flange may be located axially below the medial inlet **196** (not shown). In this configuration, the flange may inhibit (e.g., block) the downward flow of air into the lower cyclone portion **320b**.

As exemplified, the flange **392** may extend by any suitable distance around the inner perimeter of the cyclone side wall **236**. For example, the flange **392** may extend entirely around the inner surface of the cyclone sidewall **236** to define a central opening (e.g., FIGS. **44C**, **44D**, **44G**, **44H**). In other cases, the flange **392** may extend around only a portion of the inner surface of the cyclone side wall **236** (e.g., FIGS. **44A**, **44B**, **44E**, **44F**). For instance, the flange **392** may extend around only a third or a half of the way around the inner perimeter of the cyclone sidewall.

The flange **392** may also extend radially inwardly into the cyclone chamber **176** by any variable distance. For example, the flange **392** may have a maximum radial width **394** of 3 mm (see e.g., FIGS. **44C** and **44D**) or 6 mm (see e.g., FIGS. **44G** and **44H**). An advantage of a flange **392** having a greater radial width **394** is that the flange **394** may block a greater volume of air from entering the upper cyclone portion **320a**. In contrast, an advantage of a flange **392** having a smaller radial width **394** is that a smaller volume of air is blocked from flowing into the upper cyclone portion **320a**. In particular, as more air is permitted to flow upwardly into the upper cyclone portion **320a**, a lower volume of air reciprocally flows downwardly, into the lower cyclone portion **320b**.

As exemplified, the flange **392** may have a constant (e.g., uniform) radial width **394** (e.g., FIGS. **44C**, **44D**, **44G**, **44H**), or may have a variable radial width **394** along different portions of the flange **392** (see e.g., FIGS. **44A**, **44B**, **44E**, **44F**).

The radial width **394** of the flange **392** may also be fixed or adjustable. For instance, the radial width of the flange may be adjustable to be greater or smaller. For instance, the flange **392** may function similar to a rotatable iris diaphragm, such that the flange **392** may be rotated inwardly to increase the radial width **394**, and rotated outwardly to decrease the radial width **394**. Alternatively, or in addition, the flange **392** may be translated inwardly and outwardly of the cyclone chamber **176** to increase and decrease the radial width **394**, respectively. An advantage of an adjustable flange configuration is that the radial width may be changed to vary the air flow rate into the upper and lower cyclone portions, respectively. In some cases, an adjusting mechanism can be provided outside of the cyclone chamber **176** to facilitate adjusting of the radial width of the flange **392**.

In various embodiments, the flange **392** may also be configured to be planar or flat.

Alternately, or in addition, the flange may extend into the cyclone chamber in a plane that is transverse to the cyclone axis. In other embodiments, the flange may extend into the cyclone chamber at an angle to a plane that is transverse to the cyclone axis.

In other embodiments, the flange **392** may be in the form of a spiral of the like extending around part or all of the circumference of the cyclone sidewall. In embodiments where the flange **392** twists or rotates, the flange may spiral in the direction of cyclonic air flow, or counter the direction of cyclonic air flow.

Exterior Dirt Collection Chamber

The following is a discussion of an exterior dirt collection chamber, which may be used by itself or with one or

more of the cyclone with an openable sidewall, the moveable screen, the dual end walls, the medial cyclone air inlet, the axially extending member (vertically extending screen), and the dirt ejection mechanism.

Optionally, a dirt collection chamber may be provided external to the cyclone unit chamber. Dust and dirt particles ejected into the external dirt chamber may be separated from the cyclonic air flow in the cyclone chamber and, accordingly, may be prevented from being re-entrained into the flow of air. This, in turn, may increase the dirt separation efficiency of the cyclone unit. In various cases, the external dirt chamber may collect finer particles of dust and dirt, while an internal cyclone dirt chamber may collect coarser particles of dust and dirt.

Referring now to FIGS. 35-41, 48, 51, and 79-83, as exemplified, the air treatment member 116 may include a dirt collection chamber 172b located external to the cyclone chamber 176. The external dirt chamber 172b may collect finer particles of dust and dirt, which would not otherwise aggregate inside of the cyclone's internal dirt chamber 172a.

As exemplified, the external dirt chamber 172b may be in fluid communication with the cyclone chamber 176 via one or more dirt outlets 178. For instance, the dirt chamber 172b may communicate with the cyclone chamber 176 via one dirt outlet 178 (e.g., FIGS. 36-41), or two dirt outlets 178a, 178b spaced apart (e.g., FIGS. 79-83).

The dirt outlets 178 may be located in any position along the cyclone unit 170. For instance, the dirt outlets 178 may be laterally positioned along the cyclone side wall 236—e.g., between the first and second cyclone ends 240, 244—to communicate with a laterally positioned dirt collection chamber 172b. In this configuration, the dirt outlets 178 comprise slots which have any suitable axial height and which extend around at least a portion of the perimeter of the cyclone side wall 236. In the exemplified embodiments, the dirt outlets 178 are positioned toward the first cyclone end 240, and axially above the medial inlet 196. An advantage of this configuration is that the dirt outlets 178 are positioned to receive finer particles of dust and dirt carried upwardly by the upflow of air from the medial inlet 196. In other cases, the dirt outlet 178 can also be positioned at any other location along the axial height 320 of the cyclone unit 170, including at the mid-point of the cyclone unit.

As exemplified, the external dirt chamber 172b may be laterally positioned relative to the cyclone sidewall 236. In this configuration, when the first cyclone end 240 is positioned over the second cyclone end 244, the dirt chamber 172b can be sized so as to not increase the axial height of the cyclone unit 170. Alternately, some of the dirt chamber 172b may be provided above or below the cyclone unit 170.

The dirt chamber 172b may partially or fully surround the lateral side of the cyclone chamber 176. For example, the dirt chamber may be located on the side of the cyclone chamber, which is provided with the dirt outlet. If more than one cyclone dirt outlet is provided, then the dirt outlets may be in communication with a common external dirt chamber or they may each be in communication with a single external dirt chamber.

As exemplified, the external dirt chamber 172b may extend between a first end 172b₁ and an axially spaced apart second end 172b₂. The axial distance between the first and second ends may define the axial height (e.g., depth) 402 of the dirt chamber 172b. Preferably, the dirt chamber 172b extends axially along an axis, which is substantially parallel to the cyclone axis 232. In other cases, however, the dirt chamber 172b may extend along any other suitable axis.

The height or depth 402 of the dirt chamber 172 may be variably configured. For example, the dirt chamber 172b may have an axial height 402 which is approximately 1/3rd of the cyclone height 320 (e.g., FIG. 37), 1/2 of the cyclone height (e.g., FIG. 83), 2/3rd the cyclone height (e.g., FIG. 35), or substantially equal to the cyclone axial height (e.g., FIGS. 79-81). As stated previously, an advantage of a dirt chamber 172b having an axial height which is less than or equal to the cyclone height 320 is to limit the extent to which the depth (e.g., height) of the cyclone unit is increased. In other cases, however, the dirt chamber 172b may have an axial height which is greater than the cyclone unit height. For instance, FIGS. 111-113 exemplify an embodiment where the axial height of the external dirt chamber 172b is greater than the cyclone unit 170. As exemplified, when first cyclone end 240 is positioned above the second cyclone end 244, the dirt chamber 172b extends to a position below the cyclone chamber. In still yet other cases, different portions of the external dirt chamber 172b may have different axial heights.

As exemplified, the dirt chamber ends 172b₁ and 172b₂ may be positioned in any location relative to the cyclone chambers ends 240, 244. For instance, in some cases, the first dirt chamber end 172b₁ may be substantially flush with the first cyclone end 240 (e.g., FIGS. 36, and 111A). An advantage of this configuration is that the first cyclone end 240 may be concurrently openable with the first dirt chamber end 172b₁, as explained in further detail herein. For example, the first cyclone end 240 and the first dirt chamber end 172b₁ may be a common member (e.g., a single openable end wall). In other embodiments, the first dirt chamber end 172b₁ may be axially offset from the first cyclone end 240. In either case, preferably, the first dirt chamber end 172b₁ is positioned at, or proximal to, the dirt outlet 178. In this manner, dirt is ejected into the top of the dirt chamber 172b, and can fall downwardly to the second dirt chamber end 172b₂ (assuming the first chamber end 172b₁ is positioned above the second chamber end 172b₂).

Similarly, the second chamber end 172b₂ can be substantially flush with the second cyclone end 244 (e.g., FIG. 79), slightly axially offset from the second cyclone end (e.g., FIG. 81), or substantially axially offset from the second cyclone end (e.g., FIG. 37, and FIG. 111A). In cases where the second dirt chamber end 172b₂ is substantially flush with the second cyclone end 244, or slight axially offset, the second cyclone end 244 may be concurrently openable with the first dirt chamber end 172b₂. For example, the second cyclone end 244 and the first dirt chamber end 172b₂ may be a common member (e.g., a single openable end wall).

As discussed previously, optionally, one or both of the dirt chamber ends 172b₁, 172b₂ is openable to allow cleaning and emptying of the dirt collection chamber 172b. Optionally, the dirt chamber ends 172b₁, 172b₂ are concurrently openable with a respective first or second cyclone end 240, 244 to allow concurrent cleaning and emptying of the cyclone chamber and the dirt collection chamber.

For instance, as exemplified in FIG. 48, the first chamber end 172b₁ may be flush with the first cyclone end 240, and the two chambers may be concurrently openable via a single openable top lid 390. Similarly, the second dirt chamber end 172b₂ may be concurrently openable with the second cyclone end 244. For instance, as exemplified in FIGS. 79-82, the second chamber end 172b₁ may be located in the same plane as the second cyclone end 244 (e.g., FIGS. 79 and 80), or slightly axially offset (e.g., FIGS. 81 and 82), and may share a common door 352. Opening a single door (e.g., door 352) may allow concurrent cleaning and emptying of both the external dirt chamber 172b and the internal cyclone

dirt chamber **172a**. In other cases, as exemplified in FIGS. **37-40**, the dirt collection chamber **172** may have a separate door **352b** for independently emptying and cleaning the dirt chamber **172b**. For example, this configuration may be more suitable where the second dirt chamber end **172b₂** is substantially axially offset from the second cyclone end **244** (e.g., FIGS. **37-40**).

While only a single dirt chamber **172b** has been exemplified in the illustrated embodiments, it will be appreciated that the air treatment member **116** may also include more than one external dirt chamber **172b**. For example, two or more dirt chambers **172b** may be in communication with the cyclone chamber **176**. The two or more dirt chambers may be positioned, for example, on different lateral sides of the cyclone unit **170**, or on the same lateral side of the cyclone unit **170** (e.g., vertically stacked). The two or more dirt chambers may communicate with the cyclone chamber **176** via separate dirt outlets **178**, or via a single common dirt outlet. Where the cyclone unit **170** includes more than one cyclone stage (e.g., **168₁** and **168₂** in FIG. **89**), each cyclone stage may also communicate with a separate external dirt chamber, or the cyclone stages may communicate with a single external dirt chamber (e.g., via separate dirt outlets). Axially Extending Member (or Axially Extending Screen)

The following is a discussion of an axially extending member (which may be an axially extending screen), which may be used by itself or with one or more of the cyclone with an openable sidewall, the moveable screen, the dual end walls, the medial cyclone air inlet, the exterior dirt collection chamber, and the dirt ejection mechanism.

In accordance with this aspect, the cyclone chamber and/or the external dirt chamber may be provided with an axially extending member **304** which may be planar and which may be porous. The axially extending member **304** may be provided inside the cyclone chamber **176** (e.g. the dirt collection region **172a** of the cyclone chamber **176**) (see e.g., FIGS. **1-95B**), and/or can be provided inside of the external dirt collection chamber **172b** (see e.g., FIGS. **96-100**). The axially extending member may also be referred to herein as a "vertically extending member" (or a "vertical screen" if the vertically extending member is porous) when the first cyclone end **240** is positioned over the second cyclone end **244**, or when the first external dirt chamber end **172b₁** is positioned over the second external dirt chamber end **172b₂**.

Axially extending member **304** may help to dis-entrain dirt and debris from the air flow. Alternatively or in addition, axially extending member **304** may help to prevent dirt and debris being re-entrained into the air flow inside the cyclone chamber **176** (e.g. inside the dirt collection region **172a** of the cyclone chamber **176**), and/or the external dirt chamber **172b**.

Axially extending member **304** can have any configuration suitable for providing one or both of these functions. For example, axially extending member **304** may include a thin panel (e.g., a plate) which may be solid, or at least partially provided with a plurality of small apertures. The axially extending member **304** may also comprise a coarse or fine screen, or any other suitable high air permeability physical filter media that can allow the air flow to continue circulating while providing some obstruction to dirt and debris and/or providing collecting surfaces for dirt and debris.

In the exemplified embodiments, the axially extending member **304** comprises a thin panel (e.g., plate) with a plurality of small apertures **306**. The axially extending member **304** may have any suitable number of apertures. For

example, the axially extending member **304** may include at least 50 apertures, such as for example 50 to 5,000 apertures. The apertures **306** may have any suitable shape or configuration. For instance, the apertures may be circular or round (e.g., FIG. **64**), oval (e.g., FIG. **65**), rectangular (e.g., FIG. **66**), triangular, square, and/or any combination of the aforementioned shapes (e.g., FIG. **67**). In embodiments where the apertures are circular, the circular apertures may have a diameter of between 0.01"-0.5", 0.04"-0.25", or 0.06-0.125".

The axially extending member **304** may have any variably configured axial height **308**, transverse width **312**, and thickness **316**. For example, in the exemplified embodiments, each of the axial height **308** and transverse width **312**, is far greater than its thickness **316**. An advantage of this design is that it provides axially extending member **304** with a large surface area (defined by height **308** and width **312**) for obstructing and/or collecting dirt and debris, and a small volume so as to occupy only a small portion of cyclone chamber **176**. For example, each of height **308** and width **312** may be at least 500% (e.g. 500% to 100,000%) of the thickness **316**. As shown, height **308** may be 25% or more of cyclone chamber height **320** or the dirt chamber height **402** (e.g. 25% to 75% of cyclone chamber height **320**), and width **312** may be 25% or more of cyclone chamber width **324** or the dirt chamber width (FIG. **1**, e.g. 25% to 100% of cyclone chamber width **312**).

The axially extending member **304** may be connected to one or more sidewall or end wall portions of the cyclone chamber **176** and/or the external dirt chamber **172b**. For example, FIGS. **20-24**, **32-34**, **36-41** exemplify an embodiment where a vertical screen **304a** is connected to the second cyclone end wall **352a** (also referred to herein as a "vertical 'end' screen" **304a**, if the axially extending member that is attached to an end wall is porous). Similarly, FIGS. **96-100** exemplify an embodiment where the vertical end screen **304a** is connected to the second dirt chamber end wall **352b**. FIGS. **37-39** and **48-51** exemplify an embodiment wherein the axially extending member **304** is connected to a sidewall. Accordingly, axially extending member **304** may be also referred to herein as a "vertical 'side' screen" **304b**, if the axially extending member that is attached to a sidewall is porous.

If the axially extending member is connected to the second cyclone end wall **352a** and/or the second dirt chamber end wall **352b**, then the vertical end screen **304a** may be removable from the cyclone chamber/dirt chamber when the second cyclone end wall **352a** and/or the second dirt chamber end wall **352b** is opened (see e.g., FIGS. **32**, **40** and **41**, **97-98**, and **100-101**). Alternately, if the vertical screen is attached to the inner surface of the cyclone sidewall **236** or dirt chamber sidewall rather than end wall **352a** and/or **352b**, the vertical side screen **304b** remains in position even when the second cyclone end **352** is openable.

As exemplified, any number of vertical side screens **304b** may be provided inside of the cyclone chamber **176** and/or the dirt chamber. For example, there may be one vertical side screen (e.g., FIG. **52**), two vertical side screens (e.g., FIGS. **37**, **39**, **41**, **48**, **53**), three vertical side screens (e.g., FIGS. **54** and **55**), four vertical side screens (e.g., FIG. **55**), or five vertical side screens (e.g., FIG. **56**).

Similarly, any number of vertical end screens **304a** may be provided inside of the cyclone chamber **176** and/or the dirt chamber **172b**. For example, there may be one vertical end screen (e.g., FIGS. **64-71**), two vertical end screens (e.g., FIG. **72**), three vertical end screens (e.g., FIG. **75**), or four vertical end screens (e.g., FIG. **73**). In cases where more than one vertical end screen **304a** is located inside of the

cyclone unit **170** or external dirt chamber **172b**, the vertical end screens **340a** may be spaced from each other (e.g., FIG. **72**), or otherwise, connected or integrally molded to each other (e.g., FIGS. **73** and **75**). Further, they may be the same or different.

Where more than one vertical side screen **304b** is provided, the vertical side screens may be spaced in any manner inside of the cyclone chamber **176**. For instance, the vertical side screens **304b** may be evenly spaced around the entire inner circumference of the cyclone side wall **236** (e.g., FIGS. **52**, **54** and **55**). In other cases, the vertical side screens **304b** may be evenly spaced around only a portion of the inner circumference of the side wall **236** (e.g., FIGS. **56** and **57**). In still other cases, the vertical side screens **304b** may be unevenly spaced around the inner circumference of the sidewall. In still yet other cases, rather than being spaced around the inner circumference of the sidewall, the vertical screens may be vertically (e.g., axially) stacked, and may be along a common plane.

Similarly, as exemplified, the vertical end screens **304a** may be positioned at any location along the cyclone end wall **352a** and/or the dirt chamber end wall **352b**. For example, the vertical end screens **304a** may be positioned radially inwardly from the cyclone side wall **236** (e.g., FIG. **73-75**) or dirt chamber side wall, or otherwise, proximal the cyclone side wall **236** (see e.g., FIGS. **69-71**) or dirt chamber side wall. Similarly, they may be evenly spaced apart along the end wall of they may be provided on only a sector of the end wall.

The vertical side screens **304b** may have any suitable shape or design. For example, the vertical side screen **304b** may comprise an axially extending rectangular member (e.g., FIGS. **49** and **51**), a trapezoidal member (e.g., FIG. **50**), or a “shark fin” shaped member (e.g., FIG. **8**). In some cases, the vertical screen **304b** may have at least a portion which is slanted (e.g., angularly offset) (see e.g., FIG. **60**). The slanted portion may be slanted, for example, in the direction of cyclonic air flow, or in a direction counter the direction of cyclonic air flow. In still other embodiments, at least a portion of the vertical screen **304b** may be arcuate or twisted or spiraled (e.g., FIG. **61**). The twisted portion may have an angular twist in a range of 1°-720°, 10°-360°, or 30°-270°. The twisted portion may also twist in the direction of cyclonic air flow, or counter the direction of cyclonic air flow.

The vertical side screens **304b** may be positioned at various axial elevations within the cyclone chamber **176**. For example, as exemplified in FIGS. **49** and **51**, the vertical side screen **304b** may be offset from the second cyclone end **244** by an axial offset distance **482a**. The offset distance **482** may be, for example, 0-35 times, 0.25-25 times, 1-15 times, or 2-5 times the axial height **196a** of the cyclone inlet **196**. The axial elevation of the vertical screen **304b** may also be expressed relative to the position of the shroud **212** (see e.g., FIGS. **49** and **51**). For instance, the vertical side screen **304b** may be axially offset from the axially inner end **212a** of the shroud **212** by a distance **482b** of 0-40 times, 0.5-25 times, 1-5 times, or 1-3 times the cyclone inlet height **196a**. In embodiments where more than one vertical screen **304b** is located inside of the chamber **176**, the vertical side screens **304b** may be positioned at the same axial elevation (see e.g., FIG. **51**), or at different axial elevations. Preferably, in either case, the vertical side screens **304b** are positioned at an axial elevation located below the cyclone air inlet **196**.

The side vertical screens **304b** may radially extend into the cyclone chamber **176** by any variable distance. For instance, as exemplified in FIGS. **44** and **49**, the vertical side

screen **304b** may have a radial extension **312b** which spans substantially across the entire cyclone chamber **176**. In other cases, as exemplified in FIGS. **52-57**, each vertical screen **304b** may only partially extend into the cyclone chamber **176**. In cases where more than one vertical side screen **304b** is provided, each vertical side screens **304b** may have the same radial extension **312b**, or different radial extensions.

The vertical end screen **304a** may have any suitable shape or design. Optionally, if the axially extending member is connected to the second cyclone end wall **352a** and/or the second dirt chamber end wall **352b**, then the vertical end screen **304a** may be configured such that when the second cyclone end wall **352a**, **376**, **380** is opened, or when the second external dirt chamber end wall **352b** is opened, the vertical end screen **304a** may be concurrently movable with the openable end wall **352a**, **352b**, **376**, **380** to an open position (see e.g., FIGS. **32**, **40** and **41**, **97-98**, and **100-101**). In this manner, the vertical end screen **304a** may be accessible for cleaning, and dirt and debris may be removed from the vertical end screen. In other cases, the vertical end screen **304a** may not be concurrently moveable with an openable second cyclone or dirt chamber end wall, and may remain in-position when part or all of end wall **352**, **376**, **380** is opened (see e.g., FIGS. **23-24**).

For example, as exemplified, if the end wall is pivotally mounted to the cyclone unit, then a portion of the vertical end screen may contact a part of the cyclone chamber sidewall and/or dirt chamber sidewall when the end wall is pivoted open. Accordingly, the side of the vertical end screen that is spaced furthest from the pivot axis of an openable end wall may be recessed sufficiently radially inwardly towards the side with the pivot axis such that the vertical end screen may be removed from the chamber without contacting the sidewall of the chamber. For example, the vertical end screen may be thin (see, e.g., FIGS. **71a-71c**) and/or positioned offset radially inwardly towards the side of the end wall with the pivot axis (see, e.g., FIGS. **69a-69c**, **70a-70c**, **71a-71c**, **72a-72c**) and/or the side of the vertical end screen furthest from the side of the chamber with the pivot axis may be shaped to avoid contact with the chamber sidewall as the end wall is opened and the vertical end screen is withdrawn from the chamber (see, e.g., FIGS. **63-67**, **68a-68c**, **69a-69c**, **70a-70c**).

FIGS. **32-34** and **63-67** exemplify an embodiment wherein the side of the vertical end screen furthest from the side of the chamber with the pivot axis is shaped to avoid contact with the chamber sidewall as the end wall is opened and the vertical end screen is withdrawn from the chamber. In these embodiments, the vertical end screen **304a** comprises a “shark fin” design. As best exemplified in FIG. **63**, the screen **304a** curves downwardly between a first side **310a** (e.g., proximal the hinge **356**), and a distally opposed second side **310b**. The downward curvature of the screen **304a** prevents the screen **304a** from colliding (e.g., interfering) with the cyclone sidewall **236** (or dirt chamber side wall) when the door **352a** is being opened (see e.g., FIGS. **32** and **63**).

FIGS. **64-67** exemplify an embodiment of a shark fin design wherein the bottom edge **310c** of the screen **304a** is flush with the second cyclone end wall **352** (e.g., it may be secured to the end wall). FIGS. **68a-68c** and **69a-69c** exemplify another embodiment of a shark fin design wherein a portion of the bottom edge **310c**—proximal the second vertical screen side **310b**—is axially offset from the end wall **352** by an offset distance **314** (e.g., the shark fin design comprises a generally right-angular design). FIGS. **70a-70c** exemplify another embodiment of a shark fin design wherein

the bottom edge **310c**—proximal the first vertical screen side **310a**—is axially offset from the second cyclone end wall **352** by offset distance **314**. By spacing the vertical end screen a distance **314** from the end wall by a vertical support member and to the side of the end wall closest to the hinge **356**, the degree of curvature of the vertical end screen may be reduced.

It will be appreciated that in other embodiments, the vertical end screen **304a** may not necessarily curve downwardly between the first side **310a** and second side **310b**, but may otherwise have a first side **310a** which is axially elevated relative to the second side **310a**. For example, the vertical screen **304a** may slant downwardly at an angle to the vertical from an axially elevated first side **310a** to an axially depressed second side **310b** (e.g., it may be generally triangular in shape). This configuration may also ensure that that the vertical end screen **304a** does not collide (e.g., interfere) with the cyclone sidewall **236** or dirt chamber side wall when the cyclone or dirt chamber end wall **352a**, **352b** is openable.

In still other embodiments, the vertical end screen **304a** may have other suitable shapes, including a rectangular shape (e.g., FIGS. **71** to **75**), a slanted trapezoidal shape (e.g., FIG. **76**), a generally triangular shape (e.g., FIG. **77**), or an arcuate or a curved shape (e.g., FIG. **78**).

It will be appreciated that while the vertical end screen may be rigid (e.g., made of a rigid plastic and may be made of the same material as the sidewall or the end wall), the vertical end member, and optionally the vertical side screen, may be made of a resilient material. This may assist opening the end wall if the vertical end screen is secured to the end wall as the vertical screen member may deflect or bend if it contacts the chamber sidewall as the end wall is opened and the vertical screen member is withdrawn from the chamber.

In some embodiments, a single vertical end screen **340a** may comprise two or more separable parts. For instance, as exemplified in FIG. **16**, the vertical end screen **304a** may comprise two separable parts **368₁** and **368₂**, connected to the first end wall portion **380** and second end wall portion **376**, respectively, of the second cyclone end **352**. Accordingly, the separable vertical screen parts **368₁**, **368₂** may be moveable with their respective openable end wall portions (see e.g., FIG. **16**).

The vertical end screen **304a** may be either fixably mounted to the cyclone or dirt chamber end walls **352** (see e.g., FIGS. **18**, **32**, **40** and **41**), or otherwise, moveably mounted to the cyclone or dirt chamber end walls **352**. For example, FIGS. **20** and **21** exemplify an embodiment where the vertical end screen **304** is moveably mounted to the second end wall portion **376**. In this embodiment, the vertical end screen **304** may be rotated out of the cyclone chamber when the first sidewall portion **248** is removed (e.g., opened). This may facilitate cleaning of the vertical end screen **304a**.

The vertical end screen **304a** may also be permanently or removably mounted to the second cyclone chamber end wall **352a** or dirt chamber end wall **352b**. An advantage of a removably mounted screen is that the vertical end screen **304a** may be removed for cleaning or replacement when the second end wall **352** of the cyclone chamber or dirt chamber (or first cyclone sidewall portion **238**) is opened.

The vertical side screen **304b** may be fixedly or moveably mounted to the inner cyclone side wall **236**. For example, in various cases, the vertical side screen **304b** may be moveable (e.g. pivotally, translatably, and/or removably) connected to one or more sidewall portions. This can allow surfaces of axially extending member **304** to move away from sidewall

portion(s) **248**, **252** where there is greater clearance and therefore better access for the user to clean those surfaces. For instance, as exemplified in FIG. **8** axially extending member **304** is pivotally connected to a sidewall portion **248**, **252**. In FIG. **8**, axially extending member **304** is pivotally connected to the sidewall portion that remains in position. The pivoting connection may be formed by a hinge **328** that defines a rotation axis **332**. As shown, rotation axis **332** may extend through cyclone chamber **176**. In the example shown, rotation axis **332** is transverse to (e.g. perpendicular to) cyclone axis **232**.

As exemplified in FIGS. **5-6**, in embodiments where the cyclone unit **170** has an openable sidewall portion **248**, the vertical side screen **304b** may remain connected to the sidewall portion that does not have the end wall **244** attached thereto. Therefore, as exemplified, axially extending member **304** remains connected to sidewall second portion **252** when sidewall first portion **248** is moved to the open position. This allows dirt and debris that falls by gravity from axially extending member **304** (naturally or by the user brushing axially extending member **304**) to fall out of cyclone chamber **176** without interference by cyclone second end wall **244**, which in this example remains connected to sidewall first portion **248**.

In still other embodiments, as exemplified in FIG. **7**, rather than being exclusively connected to either the cyclone end wall or sidewall, the vertical screen **304** may be connected to both the inner surface of the cyclone sidewall **236** and the second cyclone end **244** (see e.g., FIG. **7**). In these embodiments, as exemplified in FIG. **7**, the axially extending member **304** may remain connected to a sidewall first portion **248** (the sidewall portion with end wall **244** attached thereto) when the sidewall first portion **248** is openable. Dirt Ejection Mechanism

The following is a discussion of a dirt ejection mechanism, which may be used by itself or with one or more of the cyclone with an openable sidewall, the moveable screen, the dual end walls, the medial cyclone air inlet, the exterior dirt collection chamber, and the axially extending member (vertically extending screen).

Optionally, a dirt ejection mechanism may be provided inside of the cyclone chamber. The dirt ejection mechanism may comprise a cleaning member that is configurable to translate axially inside of the cyclone chamber. Preferably, the cleaning member may axially translate inside of the cyclone chamber using a handle assembly which is driving connected to the cleaning member, and which is located external to the cyclone chamber. The cleaning member may be used to remove dirt which aggregates on the shroud **212** (e.g., hair which may be wrapped around shroud **212**).

Referring now to FIGS. **84-95**, as exemplified, the cyclone unit **170** may include a cleaning member **420** located inside of the cyclone chamber **176**. The cleaning member may be of various shapes. For example, cleaning member **420** may be an annular member that extends around the circumference of the shroud **212**. In the exemplified embodiments, the cleaning member **420** comprises an annular member having a radial outer surface **420a** and a radial inner surface **420b** defining a central opening (e.g., FIGS. **86**, **85b** and **90c**). Alternately, cleaning member **420** may extend only part way around the shroud **212**. For example, the cleaning member **420** may comprise a semi-annular member which only partially surrounds and engages the shroud **212** when at an axial elevation of the shroud **212**.

The radial inner surface, e.g., surface **420a**, may at least partially engage (i.e., contact) the outer surface of the shroud **212** when the annular member is at an axial elevation of the

shroud 212 (see e.g., FIGS. 88 and 89A). Optionally, all of the radial inner surface may engage the shroud 212.

While the cleaning member 420 is exemplified as an annular (or semi-annular) member, it will be appreciated that the annular shape of the cleaning member is only a function of the cylindrical shape and design of the cyclone chamber 176. Accordingly, in other cases, the cleaning member 420 may have any other suitable shape or design which is suited for the shape or design of the cyclone chamber and the shroud. For instance, the cleaning member 420 may have a square-shape, and may have a square-shaped central opening to surround a rectangular shaped shroud.

It will be appreciated that, if the shroud 212 is cylindrical, then the radial inner surface 420a may contact the shroud 212 along the entire length of the shroud 212 as the cleaning member 420 is translated axially along the length of the shroud 212. Accordingly, the cleaning member may have a radial inner surface 420a that has a constant diameter. For example, the cleaning member 420 may be made of a rigid material, such as plastic. Optionally, a resilient member, e.g., a resilient gasket may be provided to abut the shroud 212 as the cleaning member is translated axially along the shroud 212.

Alternately, if the shroud is conical, then the radial inner surface 420a may contact the shroud 212 along only a portion of the length of the shroud 212 (e.g., the upper portion if the cyclone is oriented vertically as exemplified) as the cleaning member 420 is translated axially along the length of the shroud 212.

In some embodiments, the cleaning member 420 may also have an adjustable central opening (not shown). The adjustable opening may accommodate shrouds which have changing diameters along their axial length (e.g., a tapered or frusto-conical shroud, as exemplified in FIG. 61). For example, the cleaning member 420 may be reconfigurable to maintain contact with the shroud 212 as the cleaning member 420 is translated long at least a portion of, and optionally all of, the axial length of the shroud 212.

For example, the cleaning member may be made of an elastomeric member or the cleaning member 420 may include an elastomeric member (or membrane) attached to the radial inner surface 420b that extends radially inward as the diameter of the shroud 212 against which it abuts is reduced. As the cleaning member 420 is returned to its storage position at the top of the cyclone chamber, the radial inner surface 420a may be deformed radially outwardly by the outer wall of the shroud 212. Accordingly, the elastomeric member may increase and decrease in size so as to accommodate the changing diameter of the shroud, and to otherwise clean the shroud at all points along the shroud's axial length. In other cases, the cleaning member 420 may include an adjustable mechanical aperture which dilates and contracts to accommodate the changing diameter of a tapered shroud.

As exemplified, the cleaning member 420 may be either detached (e.g., separated) or attached (e.g., connected) to the shroud 212.

FIGS. 85-88 exemplify an embodiment where the cleaning member 420 is detached from the shroud 212. In this embodiment, the shroud 212 is fixed inside of the cyclone chamber 176, and the cleaning member 420 is axially translatable, along cyclone axis 232, inside of the cyclone chamber 176. For example, the cleaning member 420 may translate between an initial storage or operating position, wherein the cleaning member 420 is located proximal (e.g., abuts) the first cyclone end 240 (e.g., FIG. 86a), to a "cleaned position" wherein the cleaning member 420 has

been translated by any suitable distance towards or to the second cyclone end 244. The storage or operating position may define the position of the cleaning member 420 during storage of the air treatment member 116 and/or operational use of the air treatment member 116. In some cases, the cleaning member 420 may travel toward the second cyclone end by only the extent of the axial length of the shroud 212 (e.g., downwardly as exemplified in FIGS. 87 and 88). In other cases, the cleaning member 420 may translate beyond the axial length of the shroud 212 (see e.g., FIG. 91). In still other cases, the second cyclone end 244 may be openable, and the cleaning member 420 may axially translate to outside of the cyclone chamber 176. Similarly, as exemplified in FIGS. 111-112, in an inverted cyclone configuration, the cleaning member 420 may be translated from an initial storage or operating position, in which the cleaning member 420 is positioned proximal (e.g., abuts) the second cyclone end 244 (FIG. 111B), to one or more "cleaned positions" in which the cleaning member 420 has been upwardly translated towards the first cyclone end 240 (FIGS. 112A-112E), and optionally, beyond an openable first cyclone end 240 to partially or fully extended out of the cyclone chamber 176 (FIG. 112F).

An advantage of the detached annular member configuration is that the cleaning member 420 may be used for scraping dust and dirt from the exterior of the shroud 212. For example, the radial inner surface 420b of the annular member may engage and wipe dirt or draw hair wrapped around the shroud 212 from the exterior of the shroud 212 as the annular member is axially translated from the first cyclone end towards the second cyclone end. The wiped dust and dirt may then collapse and aggregate inside of the cyclone's internal dirt chamber 172a. In some cases, the second cyclone end wall 352 may be opened, and the cleaning member 420 may also axially translate beyond the outside of the cyclone chamber 176. This may allow the member to be used to push debris (e.g., hair balls) entirely outside of the cyclone chamber 176. Accordingly, it will be appreciated that the cleaning member 420 can facilitate cleaning of the shroud 212 from dirt and debris without otherwise requiring the shroud 212 to be removed from inside of the cyclone chamber 176.

To enhance wiping and cleaning of dirt from the shroud 212, the radial inner surface 420b of the cleaning member 420 may be variable configured. For example, the radial inner surface 420b may be textured (e.g., roughly textured) to facilitate wiping of dirt from the shroud. The radial inner surface 420b may also include one or more scrapers (e.g., prongs) to scrape dirt from the exterior of the shroud 212 (e.g., similar to prongs 462 exemplified in FIG. 90B).

FIGS. 89A-89C exemplify another embodiment of the cleaning member 420. In this embodiment, the radial inner surface 420b of the cleaning member 420 is attached to the shroud 212. For example, the radial inner surface 420b may be permanently connected (e.g., integrally molded), or otherwise detachably connected to a non-permeable portion of the shroud 212. FIGS. 108 and 113 exemplify a configuration in which an annular plate 560 is attached (e.g., integrally molded, or detachably connected) around an axial outer end 212b of shroud 212. In this configuration, as exemplified, the cleaning member 420 is attached, at one surface, to the plate 560, to connect to the shroud 212.

In this configuration, the cleaning member 420 and the shroud 212 are concurrently moveably along all or a portion of the axial length of the cyclone chamber 176. Accordingly, as exemplified in FIGS. 89B and 89C and FIG. 108, the cleaning member 420 and the shroud 212 may be translated

from the first cyclone end **240** (i.e., the storage or operating position) towards, to or past an opened second cyclone end **244** (i.e., a cleaned position), and optionally partially or fully extended outside of the cyclone chamber **176**. Alternatively, as exemplified in FIGS. **113A-113C**, using an inverted cyclone configuration, the cleaning member **420** and the shroud **212** may be translated from the second cyclone end **244** (i.e., the storage or operating position) towards, to or past the first cyclone end **240** (i.e., a cleaned position), and optionally, partially or fully extended outside of the cyclone chamber **176**. An advantage of this configuration is that a user may access the shroud **212** from the opened first cyclone end **240** or second cyclone end **244**, as the case may be, to clean the shroud **212** from dirt and debris. Where the shroud **212** is detachably connected to cleaning member **420**, the user may further detach the shroud from the cleaning member **420** to more easily clean the shroud, or otherwise, to entirely replace the shroud **212**. In other cases, rather than translating the annular member and shroud outside of the cyclone chamber, the user may axially vibrate the annular member and shroud inside of the cyclone chamber to debride the shroud from dirt and debris.

In still other embodiments, a cleaning member **420** may not be provided, and the shroud **212** may be moveable between an initial storage or operating position, to one or more positions in which the shroud may be cleaned by a user. For example, as exemplified in FIGS. **162-163**, in an upright cyclone configuration, the shroud **212** may be moveable from the first cyclone end **240** (i.e., an initial storage or storage position) (FIG. **162B**), towards, to or past an opened second cyclone end **244** (FIGS. **163B** and **163C**). In which positions, it will be easier for a user to access the screen and clean the screen. Accordingly such positions may be referred to as cleaning positions (i.e., the user may clean the screen) or cleaned positions (i.e., the user has cleaned the screen). It will be appreciated that a screen moveable without a cleaning member may also be used in an inverted cyclone configuration.

Optionally, in embodiments in which a cleaning member **420** is provided, and irrespective of whether the cleaning member **420** is detached or attached to the shroud **212**, the radial outer surface **420a** of the cleaning member **420** may also at least partially engage the inner cyclone sidewall **236**. Accordingly, axial movement of the cleaning member **420** may also wipe (e.g., scrape) dirt from the inner surface of cyclone sidewall **236**. The radial outer surface **420a** may have any configuration to facilitate wiping of dirt from the inner cyclone sidewall **236**. For example, the radial outer surface **420a** may be flat or textured. Alternatively, or in addition, as exemplified in FIG. **90**, the radial outer surface **420a** may include one or more axially extending prongs (e.g., ribs) **462** which facilitate scraping of dirt from the cyclone side wall.

It will be appreciated that the radial inner or outer surface which contacts the shroud or sidewall may be made of a material that causes less friction as the cleaning member is moved (e.g., nylon). Alternately or in addition, the radial inner and/or outer surface may be dimensioned so as to be positioned proximate but not to contact the shroud or sidewall.

Optionally the cleaning member may be actuatable from a position exterior to the cyclone chamber. For example, if the cleaning unit includes a drive motor, then an actuation member may be provided exterior to the cyclone unit, e.g., on an outer wall of the cyclone chamber. Alternately, a handle assembly may be provided, at least partially, outside the cyclone chamber (also referred to herein as a driving

assembly, or a driving linkage). The handle assembly may be operable between a storage position (in which the assembly is retracted when the surface cleaning apparatus is in use), an extended position in which the assembly is drivingly connected to the cleaning member and/or shroud and the cleaning member and/or shroud are in the storage position (for when the surface cleaning apparatus is used for cleaning) and a cleaned position in which the cleaning member and/or shroud have been translated inside the cyclone chamber to clean the shroud **212**.

Driving Assembly

FIGS. **85-95** and **102-166** exemplify various configurations for a driving assembly which drivingly engage the cleaning member **420** and/or shroud **212**. The driving assembly can be used to translate the cleaning member and/or shroud between an initial storage or operating position, and one or more cleaned positions. In the exemplified embodiments, the drivingly assembly **436** may either extend (e.g., penetrate) through a wall of the cyclone (e.g., an end wall of sidewall **236**) to physically connect with the cleaning member and/or shroud (see for example FIGS. **85-95**, **102-113**, **116-163**), or alternately, can apply an external driving force without extending through a wall of the cyclone (see for example FIGS. **130-131**).

A. Driving Assembly Extending Through Cyclone Sidewall

FIGS. **85-95**, **102-113** and **116-163** exemplify driving assemblies which extend, at least partially, through a wall of the cyclone to drivingly engage the cleaning member **420** and/or shroud **212**. In particular, as exemplified, the driving assembly **436** may extend through: (a) the first cyclone end **240** (see for example FIGS. **104-110** and FIG. **161**), (b) the second cyclone end **244** (see for example FIGS. **111-113**); or (c) an axial gap **444** provided along the cyclone sidewall **236** (see for example FIGS. **85-95**, **102**, **116-160** and **162-163**).

(a) Driving Assembly Extending Through First or Second Cyclone End

FIGS. **104-113** and **161** exemplify an embodiment of the driving assembly **436** which extends, at least partially, into the cyclone chamber **176**, through either the first cyclone end **240** (FIGS. **104-110** and **161**) or the second cyclone end (FIGS. **111-113**), to drivingly engage the cleaning member **420** and/or shroud **212**. Optionally, as exemplified, the driving assembly **436** extends through the cyclone end wall which has the cyclone air outlet. This enables a cleaning member to be positioned in the cyclone chamber such that, when it is desired to clean the screen, the cleaning member is positioned ready to travel axially through the cyclone chamber along the screen towards, e.g., an openable end of the cyclone chamber. Accordingly, the first cyclone end **240** when the cyclone **170** is configured as an upright cyclone, and extends through the second cyclone end **244** when cyclone **170** is configured as an inverted cyclone.

In the exemplified embodiments, and as best exemplified in FIGS. **105** and **111**, the driving assembly **436** comprises an elongate member **438** (also referred to herein as a longitudinally extending driving rod, a driving rod or an elongate rod). The elongate rod **438** extends, along axis **428**, between a first end **438a** and an axially spaced apart second end **438b** (FIGS. **105** and **111B**). As exemplified, axis **428** may be generally parallel to cyclone axis **232**.

In the exemplified embodiments, the elongate rod **438** can extend through the first cyclone end **240** (FIG. **105**), or the second cyclone end (FIG. **111**). In embodiments in which the elongate rod **438** extends through the first cyclone end **240** (FIG. **105**), rod **438** can extend through an opening **802a** provided at the first end **240**. Alternatively, in embodiments

in which the elongate rod **438** extends through the second cyclone end **244** (FIG. **111C**), rod **438** can extend through an opening **802b** provided at the second end **244**. As exemplified in FIG. **161B**, in other embodiments, elongate rod **438** can also extend directly through the cyclone air outlet **204**.

Optionally, as exemplified in FIGS. **104A** and **111C**, if rod **438** extends through an opening **802** located on the cyclone end wall, a seal (e.g., a sealing gasket or the like) may be associated with an opening **802** to seal the openings **802**. For example, a seal **804a** may be provided on an inner surface of an end wall adjacent an opening **802a**, on an outer surface of the end wall adjacent an opening **802a** inside the opening **802a** (i.e., the portion of the wall defining the opening extending through the end wall between the inner and outer surface of the end wall), at the first cyclone end **240** (FIG. **104A**). Similarly, a seal **804b** may be associated with the opening **802b**, at the second cyclone end **244** (FIG. **111C**). An advantage of this configuration is that the seal members **804** can seal the openings **802** during operation of the air treatment member **116**, and otherwise prevent air flow leakage through openings **802**. Seals **804** may be formed from any suitable material to facilitate sealing of openings **802**, as well as to facilitate smooth axial movement of elongate rod **802** through the openings **802**. For example, seals **804** can be formed from one or more of felt, microfiber, polytetrafluoroethylene (PTFE), ultra-high-molecular-weight polyethylene (UHMWPE, UHMW), high-density polyethylene (HDPE), or other low friction and/or deformable materials.

As exemplified, irrespective of whether the rod **438** extends through the first or second cyclone end, the second end **438b** of the elongate member **438** may be attached to the cleaning member **420**. For instance, as exemplified in FIG. **105**, the second end **438b** may be attached to a surface (e.g., face) of the cleaning member **420** that faces towards the first cyclone end **240**. Alternatively, as exemplified in FIG. **111B**, the second end **438b** of rod **438** may be attached to a surface (e.g., face) of the cleaning member **420**, that faces towards the second cyclone end **244**.

The second end **438b**, of rod **438**, can attach to the cleaning member **420** in any manner known in the art. For example, the second end **438b** may be integrally formed with the cleaning member **420**. Alternatively, the second end **438b** may be removably attached (e.g., detachably connected) to the cleaning member **420**.

As exemplified in FIGS. **106A-106E** and **112A-112E**, the elongate rod **438** may translate axially inwardly, into the cyclone chamber **176** (e.g., along axis **428**), to translate the cleaning member **420** between an initial storage or operational position (FIG. **105** or **111B**), and one or more cleaned positions (FIGS. **106A-106E** or FIGS. **112A-112E**). Accordingly, the elongate member **438** drives movement of the cleaning member **420**, inside the cyclone chamber **176**, in a manner analogous to a plunger.

In some embodiments, as exemplified in FIGS. **108A-108C** and **113A-113E**, rather than drivingly engaging only the cleaning member **420**, the rod **438** can also drive movement of the cleaning member **420** and shroud **212**, concurrently. For example, as exemplified, the shroud **212** may be attached to the cleaning member **420**, and the shroud **212** can translate concurrently with the cleaning member **420**.

In still other embodiments, as exemplified in FIGS. **161A-161D** a cleaning member **420** may not be provided inside the cyclone **170**, and accordingly, the elongate rod **438** may be provided to drivingly engage a moveable shroud **212**. For instance, as exemplified, the elongate rod **438** may be

attached to an axially inward end **212a** of shroud **212**, so it may translate the shroud **212** between a storage position (FIG. **161B**) and a cleaned position (FIG. **161D**). In other cases, the elongate member **438** may be attached to the moveable shroud **212** at any other suitable location.

Optionally, as exemplified in FIGS. **104A** and **111C**, the elongate rod **438** can include a handle **440** (e.g., a grip). The handle or grip **440** may be provided, for example, at the first end **438a** of the elongate rod **438**, and can be used to facilitate axial movement of the rod **438** by a user.

(b) Driving Assembly Extending Through an Axial Side-wall Gap

FIGS. **85-95**, **102-103**, **114-160** and **162-163** exemplify an alternate configuration for drivingly engaging a driving assembly **436** to a cleaning member **420** and/or shroud **212** via a gap or opening provided in a sidewall of an air treatment member, such as a cyclone.

As exemplified, an axial gap **444** is provided along the cyclone sidewall **236** (FIG. **117C**) to allow at least a portion of the driving assembly **436** to extend into the cyclone chamber **176**, and to drivingly engage the cleaning member **420** and/or shroud **212**. In this manner, the driving assembly **436** can be used to translate the cleaning member **420** and/or shroud **212** between a storage or operating position, and one or more cleaned positions.

As best exemplified by FIG. **117C**, the axial gap **444** may extend, e.g., axially between a first gap end **444a**, and an axially spaced apart second gap end **444b**. Optionally, the axial gap **444** extends along an axis parallel to the cyclone axis **232**. Optionally, the first gap end **444a** is positioned proximate the first cyclone end **240**, and the second gap end **444b** is positioned proximate the second cyclone end **244**. The axial gap **444** may extend by any distance between the first gap end **444a**, and the second gap end **444b**. For example, as exemplified in FIG. **117C**, the axial gap **444** can extend substantially between the first and second cyclone ends **240**, **244**. As explained herein, an advantage of this configuration is that the axial gap **444** may allow the driving assembly **436** to engage, and translate the cleaning member **420** and/or shroud **212** completely between the first cyclone end and the second cyclone end. In other embodiments, the axial gap **444** may extend only partially between the first and second cyclone ends (FIG. **162**).

In the exemplified embodiment of FIG. **117C**, the second gap end **444b** is an open end, and is otherwise flush with the second cyclone end **244**. This configuration, as exemplified herein, may allow the cleaning member **420** and/or shroud **212** to be removed, e.g., the driving assembly **436** may be able to continue to slide axially and be removed from the cyclone chamber **176** along with the cleaning member and/or shroud.

The axial gap **444** may be positioned at any location around the cyclone sidewall **236** from the dirt outlet **178**. For instance, as exemplified in FIG. **118C**, the axial gap **444** may be provided downstream from the dirt outlet **178**, in the direction of air rotation. In the exemplified embodiment, the axial gap **444** is provided 180° around the cyclone sidewall downstream from the dirt outlet **178**. In other embodiments, the axial gap **444** can be provided, for example, 10°, 20°, 30°, 45°, 90° or 135° degrees downstream from the dirt outlet **178**.

The axial gap **444** may be sealed in any manner known in the art to prevent air leakage, through the axial gap **444**, when the air treatment member **116** is in operational use.

FIGS. **114-117** and **120** exemplify a first configuration for sealing the axial gap **444** wherein a sealing rib (or spline) is used to seal the axial gap **444**. In particular, as best exem-

plified in FIGS. 116 and 120, when it is desired to operate the air treatment member 116 the air treatment member 116 is mounted to an upright section 120 of the surface cleaning apparatus 100 (FIGS. 114 and 115). As exemplified, the air treatment member 116 is oriented vertically upright, and mounted to the apparatus 100 with the axial gap 444 facing the upright section 120 (FIG. 116C). As best exemplified in FIGS. 116A-116B, 117A-117B and 120B, in the mounted position, the axial gap 444 is sealed by a spline (or rib) 518, which axially extends, along a portion of the upright section 120, and is receivable inside the axial gap 444 to seal the axial gap 444 during operation of the air treatment member 116 (FIGS. 116C and 120B). As exemplified, rib 518 can extend across the entire depth 448 of the axial gap 444 (FIG. 116C), or across only a portion of the depth 448 of axial gap 444 (FIG. 120B). Rib 518 may have a depth such that the outer extent of rib 518 seats flush with the inner surface of the cyclone sidewall.

Preferably, the spline 518 is configured to have an axial length, and lateral width, which are substantially equal to the axial length and lateral width of axial gap 444. In this manner, spline 518 can completely seal the axial gap 444, and otherwise prevent air flow leakage through gap 444. In embodiments where a driving assembly 436 is provided, and extends through gap 444 (FIG. 116B), the spline 518 can have an axial length which is slightly less than the axial length of gap 444 so as to accommodate the driving assembly 436 extending through the gap 444. For instance, as exemplified in FIG. 116B, spline 518 can extend to a position, e.g., below or slightly below the handle 440, so as to not contact the handle 440 when the air treatment member 116 is mounted to the upright section 120. Optionally, a cavity 514 is provided, above spline 518, to receive a handle 440 when the cleaning member 420 is in the storage position. As exemplified, a lateral surface 504 may also be provided, inside the cavity 514, to rest the handle 440. A gasket or other sealing member may optionally be provided between spline 518 and the wall defining the gap 444.

The air treatment member 116 can be mounted in any suitable manner to the cleaning apparatus 100, so as to secure the air treatment member 116 to the cleaning apparatus 100. For instance, in the configuration exemplified in FIGS. 116B, 117B and 120C, a mounting structure is provided to mount the air treatment member 116 to upright section 120. As exemplified, the mounting structure can comprise one or more retention members 522, extending laterally from the upright section 120, below spline 518. Each retention member 522 can comprise a distal hook-shaped end. The hook-shaped ends engage legs 526, which depend from a bottom openable door 352 (or second cyclone end 244) of the air treatment member 116. Optionally, each leg 526 is hollowed to receive the hook-shaped ends. As exemplified, the retention members 522 support the air treatment member 116, to the upright section 120, and in engagement with spline 518. Any locking member known in the vacuum cleaner arts may be used to secure the air treatment member 116 in position.

As best exemplified in FIGS. 119A-119F, the axial gap 444 is formed between a first sidewall edge 516a and a second spaced apart sidewall edge 516b of the cyclone sidewall 236. Each sidewall edge 516 extends laterally between an outer surface 463a of the cyclone sidewall 236 and an inner surface 463b of the cyclone sidewall 236 (e.g., inside the cyclone chamber 176), to define the axial gap depth 448.

The sidewall edges 516a, 516b can be configured with any suitable design. For instance, as exemplified, in some

embodiments, each sidewall edge 516a, 516b can be configured to be substantially straight or linear (FIG. 119A), i.e., orthogonal to the inner and outer surface of the cyclone sidewall. In other cases, at least one of the sidewall edges 516 may be chamfered, or beveled (e.g., angled). For example, one of the sidewall edges 516 can be chamfered or beveled (FIGS. 119B and 119E), or both sidewall edges can be chamfered or beveled (FIGS. 119C-119D and 119F). In cases where both sidewall edges are chamfered, the sidewall edges can be chamfered at the same angle (FIG. 119C), or at different angles (FIGS. 119D and 119E). In the exemplified embodiments, the edges 516 are chamfered such that the axial gap 444 is wider inside the cyclone chamber 176 than outside the cyclone chamber 176. An advantage of using a chamfered sidewall edge is that it can minimize air flow turbulence, around the axial gap 444, during operation of the cyclone 170.

While the exemplified embodiments illustrate the entire sidewall edge 516 as being chamfered or beveled, it will be appreciated that, in other embodiments, only a portion of the sidewall edge can be chamfered or beveled. For example, only a radial inner portion of the sidewall edge (e.g., proximal the cyclone chamber 176) may be chamfered, while a radial outer portion may not be chamfered (e.g., it may be straight or linear), or vice-versa. In some cases, the portion of the sidewall edge that is chamfered may comprise 20%, 30%, 40%, 50%, 60%, or 70% of the total radially extending area of sidewall edge 516.

In embodiments in which an axial sidewall gap 444 is provided, a driving assembly 436 can extend, at least partially, through the axial gap 444, to drivingly engage the cleaning member 420 and/or shroud 212. In this manner, the driving assembly 436 is operable to translate the cleaning member 420 and/or shroud 212 axially while the driving assembly travels axially along axial gap 444 between an initial storage or operating position, and one or more cleaned positions.

FIGS. 85-95, 102, 121-129, 132-160 and 162-163 exemplify various configurations for driving assemblies which drivingly engage the cleaning member 420 and/or shroud 212 through axial gap 444. In particular, in the exemplified embodiments, the driving assembly 436 can comprise: (i) an external handle (FIGS. 121-124, 126-129 and 162-163), (ii) an elongate rod (FIGS. 85-95, 102 and 125); or (iii) a handle and/or elongate rod in conjunction with an intermediate driving mechanism (FIGS. 132-160).

(i) External Driving Handle:

FIGS. 117-125, 126-129 and 162-163 exemplify a first embodiment of a driving assembly 436, which is drivingly engaged to the cleaning member 420 and/or shroud 212 through the axial gap 444 wherein the driving assembly 436 uses a driving handle 440 whose radial inner end extends through the gap to directly contact the cleaning member 420 and/or shroud 212.

As exemplified, the handle 440 comprises a linearly extending member that extends through the gap 444 and engages the cleaning member 420 and/or shroud 212. The radial outer end of handle 440 (the portion outside the cyclone which may be gripped by a user) may be of any configuration. As exemplified, handle 440 is a linearly extending member which may be relatively short (e.g., FIG. 117A) such that the radial outer end is positioned proximate the sidewall or relatively longer (e.g., FIG. 125) such that the radial outer end is positioned spaced from the sidewall.

The handle 440 can drivingly engage the cleaning member and/or shroud in any suitable manner. For example, FIGS. 117C and 121 exemplify an embodiment where the

handle 440 is integrally formed with the cleaning member 420. In particular, as exemplified, the handle 440 comprises a lateral portion 422, of the cleaning member 420, which extends laterally or radially through axial gap 444. In this configuration, the handle 440 is in driving engagement with the cleaning member 420 (FIG. 121), or the cleaning member 420 and shroud 212 (FIG. 127) (e.g., wherein the shroud 212 is attached to the cleaning member 420). In other embodiments, in which no cleaning member 420 is provided, handle 440 may be integrally formed (or otherwise, drivingly engaged) to a moveable shroud 212 (FIG. 162). For instance, handle 440 may be integrally formed with a plate 562 that may be attached to and surround an axial outward end 212b of shroud 212. In other embodiments, handle 440 may not be integrally formed with the cleaning member 420 and/or shroud 212, but may comprise a separate member portion. The separate member portion may drivingly engage the cleaning member 420 and/or shroud 212 using any suitable attachment mechanism (e.g., a bolt or a rivet or an adhesive or the like).

As exemplified in FIGS. 121A-121C, 123A-123C, 124A-124C and 126A-126D, in embodiments where the handle 440 is drivingly engaged to the cleaning member 420, the handle 440 can translate along axial gap 444 to translate the cleaning member 420 from an initial storage or operating position (FIGS. 121A, 124B and 126A), to one more cleaned positions (FIGS. 121B-121C, 123B-123C, 124C and 126B-126D). In other cases, where the shroud 212 is attached to the cleaning member 420 (e.g., integrally formed or detachably attached), as exemplified in FIGS. 127A-127E, handle 440 can translate the cleaning member 420 and shroud 212 concurrently from a storage or operating position (FIG. 127A) to one or more cleaned positions (FIGS. 127B-127E). As exemplified in FIGS. 162-163, handle 440 can also translate only a moveable shroud 212 from a storage or operating position (FIG. 162B) to one or more cleaned positions (FIGS. 163B and 163C).

Optionally, as exemplified in FIG. 118, an external track 430 may be provided to guide axial movement of the handle 440 along axial gap 444. For instance, as best exemplified in FIGS. 118C and 118D, the hollow track 430 can be provided externally and adjacent to the cyclone sidewall 236 (e.g., on the radial outer side of the cyclone sidewall 236) and may surround or overlie the axial gap 444. As exemplified, track 430 can extend axially along axis 428 between a first end 432 and an axially spaced apart second end 434 (FIG. 118A).

The track 430 may have any suitable axial length (e.g., height) 424, which may be the same as the height of gap 444. For instance, as exemplified in FIG. 118B, the track 430 may have an axial height 424 that is substantially equal to the axial height 320 of cyclone 170. Accordingly, the first end 432 of track 430 can be located proximal the first cyclone end 240, and the second track end 434 can be located proximal the second cyclone end 244. An advantage of this configuration is that the track 430 can guide axial motion of the driving assembly 436 (e.g., handle 440) along substantially the entire axial length of cyclone 170. In other embodiments, track 430 may extend along only a portion of the axial length of cyclone 170, or may extend beyond the axial length of the cyclone 170. Optionally, the second track end 434 may be open ended to allow handle 444 to remove the cleaning member 420 and/or shroud 212 from an opened second cyclone end 240 (e.g., FIG. 127E). In various cases, this may allow a user to access the cleaning member 420 and/or shroud 212 for cleaning or replacement.

As best exemplified in FIGS. 118C-118D, track 430 comprises a first track segmented 431a, formed on one

lateral side of axial gap 444, and a second track segment 431b, formed on an opposed lateral side of axial gap 444 (radially spaced around the cyclone sidewall). In some cases, the track segments 431 may be integrally formed with the cyclone sidewall 236. Each segment forms a cavity defining a lateral portion of the track. An axial gap 447 is formed between the two track segments 431, opposite axial gap 444, to accommodate the handle 440 (FIG. 118D). As exemplified in FIG. 118D, handle 440 can include a linearly extending portion 445, which extends through the axial gap 447, track 430 and axial gap 444. Preferably, as exemplified in FIG. 118D, portion 445, itself, comprises two lateral extending portions or wings 446a, 446b, which are receivable into cavities formed inside track segments 431a and 432b, respectively. Accordingly, track 430 guides axial movement of handle 440 by guiding the lateral portions 446.

Optionally, as exemplified in FIGS. 118C and 118D, at least a portion of the track 430 can be lined with a sealing member. In particular, as exemplified in FIG. 118C, a first sealing member 690a may line the inside of first track segment 431a, and a second sealing member 690b may line the inside of the second track segment 431b. Optionally, as exemplified in FIG. 118C, the longitudinal edges of the sealing members 690a, 690b can abut each other around the axial gap 447, to seal the gap 447.

An advantage of the sealing members 690 is that they may at least partially seal the axial gap 444 during operation of the air treatment member 116. For instance, as exemplified in FIG. 120B, when rib 518 is inserted into axial gap 444 (i.e., when the air treatment member 116 is mounted to the surface cleaning apparatus 100), seal 690 can provide an additional layer of sealing protection, around the rib 518, to further prevent air flow leakage. Another advantage of the sealing member 690 is that can reduce friction between the handle 440 and track 430 (e.g., handle portions 446 and track segments 431) during movement of the handle 440 across the track 430.

The sealing member 690 may be formed from any suitable material to facilitate sealing of axial gap 444, as well as to facilitate axial movement of handle 440. Sealing member 690 is optionally flexible and may be made of any material used to form a gasket. For example, the sealing member 690 can be formed from one or more of felt, microfiber, Poly-tetrafluoroethylene (PTFE), Ultra-high-molecular-weight polyethylene (UHMWPE, UHMW), High-density polyethylene (HDPE), or other low friction and/or deformable seals.

(ii) Elongate Driving Rod:

FIGS. 85-95 and 102 exemplify an alternative configuration for a driving assembly 436, which drivingly engages the cleaning member 420 and/or shroud 212 through axial gap 444 wherein the driving assembly 436 comprises an elongate axially extending driving rod 438. Driving rod 438 may be connected to the cleaning member 420 and/or shroud 212 in a similar manner as discussed with respect to handle 440.

In the exemplified embodiment, and as best exemplified in FIG. 85, the elongate rod 438 is disposed external to the cyclone chamber 176, and extends along an axis 428, between a first end 438a and a second end 438b. Axis 428 extends generally parallel to cyclone axis 232.

As exemplified, a portion of the elongate member 438 may drivingly engage the cleaning member 420 through axial gap 444. For instance, as exemplified in FIG. 86, elongate rod 438 can drivingly engage the cleaning member 420 using one or more connecting members 460 (e.g., bolts or rivets) which extends through axial gap 444. FIGS. 87 and 158 exemplify another configuration, where the cleaning

member **420** includes a lateral portion **422**, which may be integrally formed as part of rod **438**, which extends through axial gap **444** to attach to the elongate rod **438**.

Any portion of the elongate rod **438** can drivingly engage the cleaning member **420** and/or shroud **212**. For example, FIGS. **87** and **158** exemplify an embodiment where the second end **438b**, of the elongate member **438**, drivingly engages the cleaning member **420**. Alternatively, in other cases, a mid-portion of the elongate member **438** can drivingly engage the cleaning member **420** (FIGS. **89-90**, and **102**). As discussed with respect to handle **440**, as exemplified in FIG. **87-89**, the elongate member **438** can be used to translate the cleaning member **420** between an initial storage or operating position (FIG. **87A**) and one or more cleaned position (FIGS. **87C** and **88**). In cases where the shroud **212** is attached to the cleaning member (FIGS. **89A-89C**), the elongate member **438** can also translate both the cleaning member **420** and shroud **212**, concurrently. In still other cases, where no cleaning member **420** is provided, the elongate rod **438** may drivingly engage and translate a moveable shroud **212**.

Optionally, as discussed with respect to handle **440** and as best exemplified in FIG. **102**, an external hollow track **430** may be provided adjacent to the cyclone sidewall **236**, outside of the cyclone chamber **176**.

in embodiments wherein the air treatment member **116** comprises two or more cyclonic cleaning stages **168₁** and **168₂**, arranged in series (e.g., FIG. **89**), the track **430** may have an axial length **424** that is the substantially equal to the combined axial height of both cyclonic stages. In still other embodiments, track **430** may extend along only a portion of the axial height of the cyclone **170**, or may have a height **424** that is greater than the axial height **320** of the cyclone chamber. It will be appreciated that an advantage of providing track **430** is that it may guide axial motion of the elongate member **438**. Accordingly, a longer track may guide axial movement of the elongate member **438** over a greater distance.

Optionally, the elongate member **438** can include a handle **440** (e.g., a hand grip portion) to facilitate axial movement of the elongate member **438** by a user. As exemplified in FIG. **102**, the handle **440** may be provided at the first end **438a** of the elongate member **438**. The handle **440** may be, for example, integrally formed with the elongate member **438**, or may be a separate member portion attached to the elongate member **438** (e.g., via bolt or rivet **440a**, as exemplified in FIG. **94B**).

While the exemplified embodiments have illustrated the driving rod **438** being used to engage and translate a cleaning member **420**, or a cleaning member **420** and/or shroud **212**, in other cases, the same configuration can be used to translate a moveable shroud **212** into one or more cleaned positions.

(iii) Handle and/or Driving Rod in Conjunction with an Intermediate Driving Mechanism

FIGS. **132-160** exemplify embodiments for a driving assembly **436** drivingly engaged to the cleaning member **420** and/or shroud **212** through axial gap **444** wherein the driving assembly **436** comprises a handle **440** and/or a driving rod **438**, which is drivingly engaged to the cleaning member **420** and/or shroud **212** through axial gap **444** using an intermediary driving mechanism. As exemplified, any suitable intermediary mechanism may be used to drivingly engage a handle or driving rod to the cleaning member **420** and/or shroud **212**. In the exemplified embodiments, the intermediary mechanism comprises one or more of a pulley mechanism (FIGS. **132-141**), a gear mechanism (FIGS. **142-149**),

a hydraulic or pneumatic mechanism (FIGS. **150-156**) or a Bowden cable mechanism (FIGS. **157-160**).

Intermediary Pulley Mechanism

FIGS. **132-141** exemplify different configurations for a pulley mechanism, which can function as an intermediary driving mechanism to drivingly engage a handle **440** and/or elongate rod **438**, to a cleaning member **420** and/or shroud **212**, through axial sidewall gap **444**.

FIGS. **132-134** exemplify a first configuration for the pulley mechanism. In the exemplified configuration, the pulley mechanism comprises a cord (e.g., a string) **606**, which drivingly connects handle **440** to cleaning member **420**. In particular, and as exemplified, the first end **606a** of cord **606** optionally is attached to handle **440**, and the second end **606b** of cord **606** is attached to cleaning member **420**. As exemplified in FIG. **133B**, the second end **606b** of cord **606** may extend through axial gap **444** to attach to cleaning member **420** (e.g., a lateral portion **422** of cleaning member **420**). Optionally, an opening **602** (e.g., aperture) is provided at the lateral portion **422** to attach cord **606** to cleaning member **420**.

As exemplified in FIGS. **132** and **133A**, a rotating pulley **610** is provided outside the cyclone **170**. In the exemplified embodiment, pulley **610** is rotatably secured to one or more longitudinal walls **620a** and **620b**, which depend laterally from cyclone sidewall **236**. Alternatively, pulley **610** can be secured outside of the cyclone **170** in any other suitable manner. Preferably, pulley **610** is positioned proximal the second cyclone end **244**. As exemplified, cord **606** winds around the pulley **610** to connect handle **440** to cleaning member **420**.

As exemplified in FIGS. **134A-134E**, to translate the cleaning member **420** to a cleaned position, handle **440** is "pulled" to allow cord **606** to rotate pulley **610** in a clockwise direction. Preferably, cord **606** is kept taut to allow cord **606** to rotate the pulley **610**. For example, a friction grip, between a taut cord **606** and the pulley **610**, may cause cord **606** to rotate pulley **610** as cord **606** is pulled. While cord **606** can be pulled in any direction, in the exemplified embodiment, cord **606** is pulled axially upwardly, along translation axis **428**. As exemplified in FIGS. **134A-134E**, as the cord **606** is pulled, the second end of cord **606b** applies an axial downward force to cleaning member **420** (e.g., provided the cyclone **170** is in an upright position wherein the first cyclone end **240** is positioned over the second cyclone end **244**). This, in turn, translates the cleaning member **420** from a storage or operating position (FIG. **133A**) to one or more cleaned positions (FIGS. **134A-134E**).

In some cases, as exemplified in FIG. **133B**, a lateral surface **622** may depend from the cyclone sidewall **236**, and can be used as a resting surface for the handle **440**. Preferably, the lateral resting surface **622** is located proximal the first cyclone end **240**, and is used to rest handle **440** when cleaning member **420** is in the storage position. As exemplified, lateral surface **622** may include an opening **624** to receive the cord **606**.

FIGS. **135-136** exemplify an alternative configuration for an intermediary pulley mechanism wherein the pulley mechanism comprises two rotating pulleys **610a** and **610b**, positioned outside the cyclone **170**. The rotating pulleys **610a**, **610b** may be rotatably secured to one or more depending walls **620a**, **620b**. Preferably, as exemplified, the first pulley **610a** is positioned proximal the first cyclone end **240**, while the second pulley **610b** is positioned proximal the second cyclone end **244**. Optionally, pulleys **610a**, **610b** are aligned along a common axis (e.g., translation axis **428**) when cyclone **170** is in the upright position (FIG. **135B**). As

best exemplified in FIG. 135B, cord 606 winds around the first pulley 610a, before winding around the second pulley 610b. In the exemplified configuration, handle 440 is positioned proximal the second cyclone end 244.

As exemplified in FIG. 136, with the first cyclone end 240 positioned over the second cyclone end 244, handle 440 is pulled axially downwardly, along translation axis 428, to pull cord 606. As cord 606 is pulled, cord 606 rotates pulleys 610a, 610b in opposing directions. For example, cord 606 rotates pulley 610a in a counter-clockwise direction, while rotating pulley 610b in a clockwise direction. As the cord 606 is pulled, the cord 606 applies an axial downward force to the cleaning member 420 and translates the cleaning member 420 from an initial storage or operating position (FIG. 135B), to one or more cleaned position (FIGS. 136A-136E).

FIGS. 137-139 exemplify still another configuration for an intermediary pulley mechanism using a plurality of pulleys. Similar to the configuration exemplified in FIGS. 135-136, the configuration in FIGS. 137-139 also includes two pulleys 610a, 610b, spaced apart along axis 428. In the exemplified configuration, however, cord 606 first winds around pulley 610b, which is positioned proximal the second cyclone end 244, before winding around pulley 610a, which is positioned proximal the first cyclone end 240. As exemplified, pulleys 610 may be rotatably mounted, at one end, to the cyclone sidewall 236 (FIGS. 137A and 137C).

As best exemplified in FIG. 137B, a portion of cord 606, disposed between pulleys 610a and 610b, can be attached, e.g., to the cleaning member 420 (e.g., lateral portion 422 of cleaning member 420, via aperture 602).

Optionally, as exemplified, an elongate member rod is provided, which extends along axis 428, between a first end 438a and second end 438b. Cord 606 may attach, at a first end 606a, to the second end 438b of elongate rod 438. Optionally, the first end 438a of elongate rod 438 includes a handle 440. In various cases, the elongate rod 438 can reduce the length of cord 606 required to drive the pulley mechanism.

As exemplified in FIGS. 138-139, with the first cyclone end 240 positioned over the second cyclone end 244, the cleaning member 420 is translated by pulling handle 440 and/or elongate rod 438, axially upwardly, along translation axis 428 (or in any other suitable direction). This, in turn, causes pulleys 610 to rotate. For example, pulley 610a may rotate in a counter-clockwise direction, while pulley 610b may rotate in a clockwise direction. As the cord 606 is pulled, an axial force is applied to cleaning member 420 to translate the cleaning member 420 between a storage or operating position (FIG. 137C) and one or more cleaned positions (FIGS. 138B and 139B).

As exemplified in FIG. 138, a biasing mechanism may be provided to return the cleaning member 420 to the storage position after cleaning. In the exemplified embodiment, the biasing mechanism comprises a biased spring 587. The biasing spring 587, is attached at a first end 587a to the second end 606b of cord 606. A second end 587b of the biasing spring 587 may be secured, for example, to the cyclone sidewall 236. As exemplified in FIG. 137B, the biased spring 137b is biased to a compressed position when the cleaning member 420 is in the storage position. As the cleaning member 420 is translated to a cleaned position (FIGS. 138A and 139A), spring 587 is extended. Once handle 440 and/or elongate member 438 is released, the spring 587 can retract to return the cleaning member 420 back into the storage position.

It will be appreciated that, while an elongate rod 438 has only been provided in the configuration exemplified in FIG. 138-139, the elongate member 438 can also be provided with any of the configurations previously exemplified in FIGS. 132-136. For example, in the previously exemplified configurations, rather than attaching a handle 440 to the first end of cord 606, the first end of cord 606 may attach to an elongate rod 438 as exemplified in FIGS. 137-139.

FIGS. 140-141 exemplify still yet another configuration for an intermediary pulley mechanism which uses a continuous loop belt system. As exemplified, handle 440 is attached to a flexible belt 628. Flexible belt 628 loops (e.g., winds) around, e.g., a first pulley 610a and a second pulley 610b. Preferably, as exemplified, the first pulley 610a is located proximal the first cyclone end 240 and the second pulley 610b is located proximal the second cyclone end 244. Optionally, the pulleys 610a, 610b are aligned along a common axis (e.g., translation axis 428). As exemplified, the pulleys 610 may be supported to one or more depending longitudinal walls 620a, 620b.

In the exemplified embodiment, a portion of belt 628 is attached to a portion of cleaning member 420 (e.g., lateral portion 422), through axial gap 444 (FIG. 140B). In some embodiments, belt 628 may be a single "continuous" member, which extends "through" each of the handle 440 and the cleaning member 420. In other embodiments, belt 628 can comprise one or more "discontinuous" members. For instance, as exemplified, belt 628 may comprise a first belt segment 628a, connecting the cleaning member 420 to handle 440, and a second belt segment 628b, connecting the handle 440 to the cleaning member 420 (FIG. 140B).

As best exemplified in FIG. 140B, when the cleaning member 420 is in the storage or operating position, handle 440 is disposed proximal the second pulley 610b (e.g., proximal the second cyclone end 244). As exemplified in FIGS. 141A-141E, when the cyclone is in the upright position (e.g., the first cyclone end 240 is positioned over the second cyclone end 244), handle 440 is translated axially upwardly, along translation axis 428. This, in turn, causes belt 628 to engage and rotate pulleys 610a, 610b. In the exemplified configuration, pulleys 610 are rotated in the same direction (e.g., clockwise) by belt 628. As the belt 628 is rotated, the belt 628 translates the cleaning member 420 from a storage or operating position (FIG. 140B), to one or more cleaned positions (FIGS. 141A-141E). To return the cleaning members 420 back to the storage position, handle 440 is translated in the reverse direction, and axially downwardly.

While the exemplified embodiments illustrate the pulley mechanisms as drivingly engaging only the cleaning member 420, it will be appreciated that the same pulley mechanisms can also drivingly engage the cleaning member 420 and shroud 212, concurrently (i.e., in cases where the shroud 212 is attached to the cleaning member 420), or alternatively, only a moveable shroud 212.

Further, while the exemplified embodiments illustrate the pulley mechanism as having either a single pulley (FIGS. 132-134), or two pulleys (FIGS. 135-141), in other embodiments, any number of pulleys may be provided. For example, cord 606 or belt 628 may wind around three, four or five pulleys.

Still further, while the exemplified embodiments illustrate a "pulley" in conjunction with a "cord" or "belt", in other embodiments, any suitable pulley-type mechanism can be used to drivingly engage the cleaning member 420 and/or shroud 212. For example, a chain and sprocket mechanism can be used in place of the cord or belt and pulley system.

In particular, an advantage of the chain and sprocket mechanism is that there is reduced “slip” between the chain and the sprocket, thereby allowing the chain 606 to more fully engage and rotate the sprocket 610.

In still yet other embodiments, members 610 may not comprise rotating pulley members (e.g., rotating pulleys or sprockets), but may comprise stationary members. For example, members 610 can comprise stationary knobs, and cord 606 or belt 628 can loop around the knobs 610. In this configuration, the cord or belt simply “slides” over the surface of the knob 610 and, in turn, translates the cleaning member 420 and/or shroud 212 from the storage position to one or more cleaned position. Optionally, in this configuration, the cord or belt, and knob 610 are formed from low-friction material to facilitate “slipping” of the surfaces over each other.

Intermediary Gear Mechanism

FIGS. 142-149 exemplify still further embodiments for an intermediary mechanism which can drivingly engage a handle 440 and/or elongate rod 438 to a cleaning member 420 and/or shroud 212, through an axial sidewall gap 444 wherein the intermediary mechanism comprises an intermediary gear mechanism.

FIGS. 142-143 exemplify a first configuration for the intermediary gear mechanism. As exemplified, an elongate rod 438 is provided, and extends between a first end 438a and an axially opposed second end 438b, along axis 428. The second end 438b attaches to the cleaning member 420 (e.g., a lateral portion 422 of the cleaning member 420, which extends through axial gap 444). In other cases, any other portion of the elongate member 438 may attach to the cleaning member 420. Optionally, a handle 440 is provided at the first end 438a of the elongate member 438. Optionally, elongate rod may concurrently move the shroud and the cleaning member or only the shroud.

As exemplified in FIGS. 142A and 142C, elongate member 438 includes laterally opposed faces 642a, 642b, which are, at least partially, axially lined with “teeth”. The axial teeth are configured to mate (i.e., in threaded engagement) with teeth disposed on rotating gears 632a, 632b. As exemplified, gears 632 are provided outside cyclone 170, and on either side of rod 438. In the exemplified embodiment, gears 632a, 632b, are provided proximal the first cyclone end 240. In other cases, gears 632 may be provided at any other location along, or beyond, the axial length of cyclone 170. As exemplified, gears 632 may be rotationally supported on cyclone sidewall 236. Preferably, in the upright cyclone position (e.g., the first cyclone end 240 is positioned over the second cyclone end 244), gears 632 are aligned along the same horizontal axis.

As exemplified in FIGS. 143A-143E, the elongate rod 438 is translated, along axis 428, toward the second cyclone end 244, to translate the cleaning member 420 into a cleaned position. As the elongate rod 438 is translated, teeth disposed along lateral faces 642 of the elongate rod 438 engage gears 632. This, in turn, causes gears 632 to rotate in opposing directions. In the exemplified embodiment, gear 632a rotates in a clock-wise direction, while gear 632b rotates in a counter-clockwise direction (FIG. 142C).

As the elongate member 438 is translated toward the second cyclone end 244, the elongate member 438 axially translates the cleaning member 420 from the storage or operating position (FIG. 142B), to one or more cleaned positions (FIGS. 143A-143D). To return the cleaning member 420 to the storage or operating position, the elongate rod 438 is translated, in reverse, axially away from the second cyclone end 244.

It will be appreciated that an advantage of the exemplified gear configuration is that the friction fit between teeth disposed on rod 438 and gears 632 allows the cleaning member 420 to be secured at various intermediate cleaned positions. In other words, the friction fit between teeth on rod 438 and gears 632 may prevent the cleaning member 420 from collapsing, under the influence of gravity, inside of the cyclone chamber 176, at different cleaned positions.

While two gears 632 have been exemplified in FIGS. 142-143, it will be appreciated that any number of gears may be provided to engage teeth along the elongate rod 438 (e.g., one, two, three, or four gears). The gears 632 may be positioned at any location along, or beyond, the axial length of the cyclone 170.

FIGS. 144-147 exemplify another configuration for an intermediary gear mechanism. In the exemplified configuration, two elongate members 438₁, 438₂ are provided, each extending axially between a respective first end 438a₁, 438a₂ and a respective second end 438b₁, 438b₂, along axis 428. The second end 438b₂, of the second elongate member 438₂, is attached to a lateral portion 422 of cleaning member 420, extending through axial gap 444 (FIGS. 144 and 145A). Alternatively, any other portion of the second elongate member 438₂ may attach to the cleaning member 420. Optionally, the first end 438a₁, of elongate member 438, include a grip handle 440.

As exemplified, each elongate member 438 includes a respective lateral face 642₁ and 642₂, which is axially lined with teeth. A rotating gear 632 is disposed between the elongate members 438, and includes teeth which are in threaded engagement with teeth disposed on each elongate member 438. As exemplified, gear 632 may be supported to cyclone sidewall 236, and may be positioned proximal the first cyclone end 240. While only a single gear is exemplified, in other cases, any number of gears may be provided and positioned between the first and second elongate members 438. The gears may also be positioned at any point along, or beyond, the axial length of cyclone 170.

As exemplified, in the storage or operating position (FIG. 145B), the first end 438a₁, of the first elongate member 438₁, is located more proximal to the first cyclone end 240, than the first end 438a₂ of the second elongate member 438₂.

As exemplified in FIGS. 146-147, to translate the cleaning member 420 to a cleaned position (e.g., with the cyclone in the upright position), the first elongate member 438₁ is pulled axially upwardly. This, in turn, causes teeth disposed on the lateral face 642₁ of the first elongate member 438₁ to engage and rotate gear 632 (i.e., translating the linear axial movement of the elongate member, into rotational gear movement). As the gear 632 rotates, threaded engagement between gear 632 and teeth on the second elongate member 438₂ causes the second elongate member 438₂ to translate axially downwardly (i.e., translating rotational gear movement back into linear axial movement of the elongate member). Accordingly, the second elongate member 438₂ is translated downwardly, and translates the cleaning member 420 from the storage or operating position (FIG. 145B) to one or more cleaned position (FIGS. 146B and 147B).

As exemplified in FIG. 147A, in the cleaned position, the first end 438a₁ of the elongate member is located more distally from the first cyclone end 240 than the first end 438a₂ of the second elongate member.

To return the cleaning member 420 back into the storage position, the first elongate member 438₁ may be translated, in reverse, axially downwardly.

While the exemplified configurations illustrate the gear mechanism as driving the cleaning member 420 through an

axial sidewall gap **444**, in other embodiments, the gear mechanism can also drivingly engage the cleaning member **420** through an opening in the first or second cyclone ends, such as in a similar as previously discussed with respect to the driving assembly extending through first or second cyclone end. FIGS. **148-149** exemplify a configuration for an intermediate gear mechanism which drivingly engages the cleaning member **420** through the first cyclone end.

As best exemplified in FIG. **148**, in this configuration, the elongate rod **438** extends into the cyclone chamber **176**, through the cyclone air outlet **204**. Optionally, as exemplified, shroud **212** can extend along the axial length of cyclone **170**. As exemplified, when cleaning member **420** is in the storage position (FIG. **148B**), the second end **438b** of rod **438** engages (e.g., abuts) an axially inward end **212a** of shroud **212**. In other cases, rod **438** can be shorter than shroud **212**, and may not abut the inward end **212a** of shroud **212**. In still other cases, shroud **212** may have a shorter length and may not extend along the axial length of cyclone **170** (e.g., it may engage the shroud proximate end **212b** of shroud **212**).

As exemplified, elongate rod **438** includes lateral faces **642a**, **642b**. Each lateral face **642** is at least partially axially lined with teeth. Teeth on lateral faces **642** are in threaded engagement with teeth on rotating gears **632a**, **632b**. In the exemplified embodiment, gears **632** are rotationally mounted inside cyclone **170**. For example, gears **632** are rotationally mounted inside shroud **212** (e.g., a non-permeable portion of shroud **212**). In the upright cyclone position (e.g., the first cyclone end **240** is positioned over the second cyclone end **244**), gears **632** are preferably aligned along a common horizontal axis. In other cases, gears **632** may be laterally offset, i.e., along different horizontal axis, or may be positioned at any other location along the axial length of cyclone **170**. It will be appreciate that, in other embodiments, the gears may be located elsewhere.

As exemplified, a hollowed stem **648** is attached, at one end, to the cleaning member **420**. Hollowed stem **648** extends axially upwardly from the first cyclone end **240**, along cyclone axis **232**. In the exemplified embodiment, hollowed stem **648** at least partially surrounds the elongate rod **438**. As exemplified in FIG. **148C**, the inner surface of hollowed stem **648**, is axially lined with teeth **652a**, **652b**. Teeth **652** engage an outer edge of gears **632a**, **632b**, opposite the edge engaging lateral faces **642** of elongate rod **438**. Accordingly, each gear **632** is positioned between the elongate rod **438**, and an inner surface of the hollowed stem **648** lined with teeth. It will be appreciate that, in other embodiments, a hollowed stem **648** may not be provided. In such a case, the elongate rod may be connected to the cleaning member via an axial gap in the shroud.

As exemplified in FIGS. **149A-149E**, in the upright cyclone position, the cleaning member **420** is translated into a cleaned position by pulling the elongate rod **438**, axially upwardly. This, in turn, causes teeth, disposed on the elongate rod **438** (i.e., lateral faces **642**), to engage gears **632**, and to cause rotation of gears **632**. For example, gear **632a** is rotated in a counter-clockwise direction, while gear **632b** is rotated in a clockwise direction. Gears **632**, in turn, engage teeth **652**, lining the inner surface of hollow stem **648**. As gears **632** rotate, and engage teeth **652** along hollow stem **648**, the gears' rotational motion is translated into linear motion of the hollow stem **648**. In particular, the hollow stem **648** is translated axially downwardly, into the cyclone chamber **176**, such as to move the cleaning member **420** from a storage or operating position (FIG. **148B**), to one or more cleaned positions (FIGS. **149A-149E**).

To return the cleaning member **420** back into the storage position, the elongate rod **438** can be translated, in reverse, axially downwardly. This, in turn, reverses rotation of gears **632**, and accordingly, translates the hollow stem **648** and cleaning member **420** back into the storage position.

It will be appreciated that while the configuration exemplified in FIGS. **148-149** has been exemplified with an upright cyclone, the same configuration can be applied to an inverted cyclone, where the air outlet **204** is provided at the second cyclone end **244**.

Further, while the illustrated embodiments exemplify the gear system as translating only the cleaning member **420**, in other cases, the gear system can translate the cleaning member **420** and shroud **212**, concurrently. For example, this can occur where the shroud **212** is attached to the cleaning member **420**. In other cases, where a cleaning member **420** is not provided, the gear system can drivingly engage only a moveable shroud **212**.

Further, in other embodiments, the elongate rod **438** may extend through an opening in the end wall of the cyclone chamber.

Intermediary Pneumatic or Hydraulic Mechanism

FIGS. **150-156** exemplify still another embodiment for an intermediary mechanism which drivingly engages a handle **440** and/or elongate rod **438** to a cleaning member **420** and/or shroud **212** wherein the intermediary mechanism comprises a pneumatic or hydraulic mechanism.

FIGS. **150-151** exemplify a first configuration for an upright hydraulic or pneumatic mechanism in which the hydraulic or pneumatic system includes a first elongate member **438₁** and a second elongate member **438₂**. The first elongate member **438₁** is slidably received inside of a first cylinder **658₁**. The second elongate member **438₂** is slidably received inside of a second cylinder **658₂**. In the exemplified embodiment, the elongate members **438** and cylinders **658** are configured with a circular cross-section. Preferably, the 'cross-sectional diameter' of the elongate members **438** is substantially equal to the 'cross-sectional diameter' of cylinders **658**, to provide for a "sealed" sliding engagement between the two components. In other embodiments, the elongate members **438** and cylinders **658** may have any other suitable cross-sectional design (e.g., a rectangular cross-section, or a triangular cross-section, etc.)

As exemplified in FIG. **150**, each cylinder **658** axially extends between a respective first end **658a₁**, **658a₂**, and an axially spaced apart second end **658b₁**, **658b₂**. The first elongate member **438₁** is slidably received through an opening at the first end **658a₁**, of the first cylinder **658₁**. Similarly, the second elongate member **438₂** is slidably received through an opening at the second end **658b₂** of the second cylinder **658₂**. As exemplified, the second end **438b₂**, of the second elongate member **438₂**, is drivingly engaged to the cleaning member **420** (e.g., portion **422**, which may laterally extend from cleaning member **420** through axial sidewall gap **444**) (FIG. **151A**).

As exemplified in FIG. **151**, the first cylinder **658₁** is in fluid communication with the second cylinder **658₂** through an intermediate tube **658₃**. Tube **658₃** connects an opening, provided at the second end **658b₁** of the first cylinder **658₁**, to an opening provided at the first end **658a₂** of the second cylinder **658₂**. The internal volume of cylinders **658₁**, **658₂** and tube **658₃** is filled with a compressible fluid (e.g., a hydraulic system) or a pressurized gas medium (e.g., a pneumatic system).

Optionally, the second end $658b_2$ of the second cylinder 658_2 is secured to a lateral portion 622 , which depends from the cyclone sidewall 236 (FIG. 150), proximal the first cyclone end 240 .

In the storage position (FIG. 151A), the first elongate member 438_1 at least partially extends out of the first cylinder 658_1 , while the second elongate member 438_2 is at least partially received inside of the second cylinder 658_2 .

As exemplified in FIGS. 151B-151C, in the upright cyclone position, the cleaning member 420 is translated into the cleaned position by compressing (e.g., sliding axially inwardly) the first elongate member 438_1 into the first cylinder 658_1 . This, in turn, applies a positive compressive pressure to the fluid or gas medium inside the connected system (i.e., cylinders and tube system 658). The positive compressive pressure, in turn, forces (i.e., pushes) the second elongate member 438_2 , axially outwardly of the second cylinder 658_2 (FIGS. 151B and 151C). In this manner, the second elongate member 438_2 axially translates the cleaning member 420 from the initial storage or operating position (FIG. 151A), to one or more cleaned positions (FIGS. 151C and 151C).

When it is desired to return the cleaning member 420 back to the storage position, the first elongate member 438_1 is reversed, and extended (i.e., pulled) out of the first cylinder 438_1 . This, in turn, results in a build-up of negative pressure inside of the connected system, and drives the second elongate member 438_2 to retract into the second cylinder 658_2 (e.g., to translate the cleaning member 420 back into the storage position).

FIGS. 152-153 exemplify an alternative configuration for an intermediary pneumatic or hydraulic mechanism which operates inversely to the configuration exemplified in FIGS. 150-151. In particular, in the storage position (FIG. 153A), the first elongate member 438_1 is substantially received inside of the first cylinder 658_1 . Further, the second elongate member 438_2 is substantially extended out of the second cylinder 658_2 . In the exemplified embodiment, the second cylinder 658_2 is secured, at one end, to a depending lateral wall $622b$, located proximal the second cyclone end 244 (FIG. 152).

As exemplified in FIGS. 153B-153C, in the upright cyclone position, the cleaning member 420 is translated by extending (i.e., pulling) the first elongate member 438_1 out of the first cylinder 658_1 . This, in turn, generates a build-up of negative pressure inside the connected system (i.e., cylinders and tube 658). The build-up of negative pressure draws the second elongate rod 438_2 into the second cylinder 658_2 . As the second elongate rod 438_2 is drawn into cylinder 658_2 , the second elongate rod 438_2 translates the cleaning member 420 from the storage or operating position (FIG. 153A) to one or more cleaned positions (FIGS. 153B and 153C).

To return the cleaning member 420 back into the storage position, the first elongate member 438_1 is inserted (i.e., slidably translated) into the first cylinder 658_1 . This generates a build-up of positive pressure which drives the second elongate member 438_2 to slide out of the second cylinder 658_2 , and to translate the cleaning member 420 back into the storage position.

While the exemplified configurations (FIG. 150-153) illustrate a pneumatic or hydraulic system drivingly engaging a cleaning member 420 , it will be appreciated that, in other embodiments, the pneumatic or hydraulic system can also drivingly engage both the cleaning member 420 and shroud 212 (e.g., in cases where shroud 212 is attached to cleaning member 420). Alternatively, where no cleaning

member 420 is provided, the pneumatic or hydraulic system can drivingly engage only a moveable shroud 212 .

FIGS. 154-156 exemplify a configuration for an intermediary pneumatic or hydraulic mechanism which drivingly engages only a moveable shroud 212 . In the exemplified configuration, a single cylinder 658_1 is connected, at one end $658b_1$, to a connecting tube 658_3 (FIGS. 154A and 154B). Connecting tube 658_3 is connected, at an opposite end, to cyclone 170 , and is in fluid communication with a passage 650 , located inside the cyclone 170 . As exemplified, passage 650 may be located along the first cyclone end 240 , above the shroud 212 .

As exemplified in FIG. 154C, passage 650 feeds into a first pipe member 656 which extends, at least part way, inside of shroud 212 , when shroud 212 is in the storage position. In the storage position, a second pipe member 657 is nested inside the first pipe member 656 . Each of the first and second pipe members 656 , 657 extend, along axis 232 , between a respective first end $656a$, $657a$ and a respective second end $656b$, $657b$. The first end $656a$, of pipe member 656 , is in fluid communication with passage 650 . The second end $657b$, of second pipe member 657 , is attached to an axial inner end $212a$ of shroud 212 .

As exemplified in FIGS. 154B and 154C, in the storage position, the second pipe member 657 is nested, at least partially, within the first pipe member 656 . Further, the elongate member 438 is substantially removed from the cylinder 658_1 .

As exemplified in FIGS. 155-156, when the cyclone 170 is in the upright position, the moveable shroud 212 is translated into a cleaned position by compressing (e.g., sliding) the elongate member 438 , into cylinder 658_1 , to generate positive pressure inside the connected system. The positive pressure causes pressurized gas or liquid to flow from tube 658_3 into cyclone passage 650 . From the cyclone passage 650 , the pressurized medium flows into the second pipe member 657 , and forces the second pipe member 657 to telescope out of the first pipe member 656 . In this manner, the shroud 212 is axially translated from the storage position (FIG. 154B), to one or more cleaned positions (FIGS. 155-156). In some cases, a friction fit engagement between the outer surface of the second pipe member 657 , and the inside surface of the first pipe member 656 , prevents the second pipe member 657 from collapsing (e.g., sliding) out of the first pipe member 656 . In other cases, any other retention structure or mechanism can be used to secure the second pipe member 657 inside the first pipe member 656 in a telescoping arrangement, as, for example, explained in further detail herein with reference to FIG. 103.

It will be appreciated that while the exemplified pneumatic or hydraulic designs are shown as drivingly engaged to the cleaning member 420 and/or shroud 212 through an axial sidewall gap 444 , in other cases, the exemplified pneumatic or hydraulic systems can also be used where the elongate member 438 extends, for example, through the first cyclone end 240 or second cyclone end 244 , as previously exemplified. For example, the second elongate member 438_2 , exemplified in FIGS. 150-153, can extend through an opening 802 in the first cyclone end (e.g., FIGS. 150-151), or the second cyclone end (e.g., FIGS. 152-153), to drivingly engage the cleaning member 420 and/or shroud 212 .

Intermediary Bowden Cable Mechanism

FIGS. 157-160 exemplify another embodiments for an intermediary mechanism, which drivingly engaging a handle 440 and/or elongate member 438 to a cleaning member 420 and/or shroud 212 wherein the intermediary mechanism comprises a Bowden cable system.

FIGS. 157-158 exemplify a first configuration for the Bowden cable system. As exemplified, the system includes a flexible elongate member (or flexible cable) 438, which extends between a first end 438a and a second end 438b. The second end 438b of may attach to the cleaning member 420 (e.g., to a lateral portion 422 of cleaning member 420, which may extend through axial gap 444). In other cases, any other portion of the flexible member 438 may attach to the cleaning member 420.

As exemplified, the flexible member 438 travels, at least partially, through a hollow flexible sleeve 626. The sleeve 626 may have a first open end 626a, to receive the flexible member 438, and a second open end 626b, through which the flexible member 438 exits the sleeve 626. In the exemplified embodiment, the second end 626b is secured to a depending lateral portion 622a of cyclone sidewall 236.

In the exemplified configuration, and as best exemplified in FIGS. 158A-158E, mechanical force, or energy, is translated to the cleaning member 420 by movement of the flexible member 438 relative to the outer sleeve 626. In particular, this allows translation of the cleaning member from a storage or operating position (FIG. 158A) to one or more cleaned positions (FIGS. 158B-158E).

Optionally, a portion of the flexible member 438 may comprise a spring member. For example, as exemplified in FIG. 157B, the flexible member 438 may comprise at least two solid portions 604a and 604c, located proximal the first and second ends 438a, 438b, respectively. Further, a middle portion 604b, disposed between portions 604a and 604c, may comprise a spring member.

Optionally, a spring may be provided between handle 440 and sleeve end 262a to bias the handle 440 to the operating position shown in FIG. 157B.

FIGS. 159-160 exemplify another configuration of the Bowden cable design which does not include an outer sleeve 626, and only includes the flexible member 438.

While the exemplified embodiments illustrate the Bowden cable design as drivingly engaging only the cleaning member 420, the Bowden cable design can also be used to translate the cleaning member 420 and shroud 212, concurrently, or otherwise to translate only a moveable shroud 212.

Further, it will be appreciated that while the exemplified Bowden cable design is exemplified as being drivingly engaged to the cleaning member 420 and/or shroud 212 through an axial sidewall gap 444, the Bowden cable design can also be used where the elongate member 438 extends through the first cyclone end 240 or second cyclone end 244, as previously exemplified. For example, the elongate member 438 can extend through an opening 802 in the first or second cyclone end to drivingly engage the cleaning member 420 and/or shroud 212.

B. Driving Assembly Engaging Cleaning Member and/or Shroud without Extending Through Cyclone Sidewall

As exemplified in FIGS. 130-131, a driving assembly 436 may drivingly engage the cleaning member 420 and/or shroud 212 without extending (e.g., penetrating) through the cyclone sidewall 236.

In the exemplified configuration, the driving assembly 436 comprises an external handle 440 (e.g., disposed outside cyclone 170), which drivingly engages the cleaning member 420 through magnetic coupling. As exemplified, a magnet pair is provided which includes a first magnet 584a, disposed, e.g., on an inner surface 441a of handle 440, facing the cleaning member 420. A second magnet 584b is disposed, e.g., on a radial outer surface 420a of the cleaning member 420 and directed towards the handle 440. The

magnets 584a, 584b are configured with opposite polarities to induce a magnetic attractive coupling force. When the cyclone is in the upright position (e.g., the first cyclone end 240 is positioned over the second cyclone end 244), magnets 584a and 584b are aligned along a common vertical and horizontal axis. As exemplified in FIGS. 131A-131D, the magnetic coupling between magnets 584 allows the external handle 440 to axially translate cleaning member 420 between an initial storage or operating position (FIG. 130) and one or more cleaned positions (FIGS. 131A-131D).

While the exemplified embodiment illustrates a portion of handle 440 extending through sidewall gap 444, it will be appreciated that the exemplified magnetic coupling design can operate without any gap or opening in the cyclone sidewall 236. This is because coupling between magnets 584 can operate through the cyclone sidewall. An advantage of this configuration is that it avoids the need to seal an opening or gap in the cyclone sidewall 236, during operation of the air treatment member 116.

Additionally, while the exemplified embodiments illustrate a single magnet pair coupling handle 440 to cleaning member 420, in other embodiments, any number of magnets (or magnet pairs) can be provided on handle 440 or cleaning member 420, to generate a magnet coupling force.

Still further, it will be appreciated that magnetic coupling may be achieved without disposing a magnet on each of the handle 440 and cleaning member 420. For example, magnetic coupling can still be achieved by disposing one magnet on handle 440 or cleaning member 420, and disposing a magnetically attractable material (e.g., a ferromagnetic material) on the opposing surface. For example, the cleaning member could be made of such a material.

While the exemplified embodiment illustrate the handle 440 as drivingly engaging only the cleaning member 420, in other cases, the handle 440 may drivingly engage both the cleaning member 420 and shroud 212 (e.g., where the shroud 212 is attached to the cleaning member 420). Alternative, where no cleaning member 420 is provided, the handle 440 may drivingly engage only the shroud 212.

The magnetic coupling configuration, exemplified in FIGS. 130-131 can be applied to any of the previously exemplified configurations which comprise a driving assembly 436. In particular, magnetic coupling can allow coupling of the driving assembly 436 to the cleaning member 420 and/or shroud 212 without an axial gap 444 in the cyclone sidewall 236.

Stop for Limiting Axial Translation of Cleaning Member and/or Shroud

Optionally, irrespective of the driving assembly used to translate the cleaning member 420 and/or shroud 212 from a storage (or operating) position, to one or more cleaned positions, a stopping mechanism may be provided to limit axial movement of the shroud 212 and/or cleaning member 420.

FIGS. 128-129 exemplify a configuration for limiting axial movement of the shroud 212 wherein each of the shroud and the cleaning member may be moved concurrently and, optionally, wherein the cleaning member may be moved separately from the shroud. In order to enable the shroud and the cleaning member to move concurrently and, subsequently, for the cleaning member to move independent of the shroud, the cleaning member is removably attachable to the shroud or a member attached to the shroud (e.g., a plate 562). Cleaning member may be removably attachable to the shroud or a member attached to the shroud by magnets or mechanical inter-engagement members that are releasably connected together.

67

In the exemplified configuration, the driving assembly 436 comprises a handle 440 in driving engagement with the cleaning member 420, through axial gap 444. As best exemplified in FIG. 129, a plate 562 surrounds and is attached to an axial outer end 212b of shroud 212. As exemplified, a stop structure 565 depends laterally from the plate 562 (e.g., from a radial outer edge of plate 562), and extends across axial sidewall gap 444.

In the storage or operating position (FIG. 128), the plate 562 is positioned axially above the cleaning member 420 (e.g., assuming the cyclone 170 is in an upright position), and the stop structure 565 overlies the handle 440.

From the initial storage or operating position, the shroud 212 and cleaning member 420 (which as exemplified is attached to the plate by magnetic coupling between plate 562 and the cleaning member 420) are concurrently translated, part or all the way along the axial length of the cyclone chamber 176, into a cleaned position (FIG. 129A) by handle 440.

As exemplified in FIG. 129A, the plate 562 may include one or more magnets 569. Magnets 569 on plate 562 are attracted to plate 560, disposed on an axial upper surface of the cleaning member 420. Plate 560, may be at least partially, comprised of magnetically attractable material (e.g., a magnet of an opposite polarity to magnets 569, or otherwise, a ferromagnetic material). Alternatively, rather than providing a plate 560, the cleaning member 420 may be formed of a magnetically attractable material (or at least a portion of the cleaning member 420 directed to plate 562). In still other cases, plate 560 or cleaning member 420 may be formed of a magnetic material, and elements 569 may comprise a ferromagnetic material. The cleaning member 420 and shroud 212 may also be detachably connected to each other in any other suitable manner known in the art.

As exemplified, magnetic coupling between plates 560 and 562 allows the shroud 212 to concurrently translate with the cleaning member 420, as handle 440 is axially translated.

As exemplified in FIG. 128, a grooved (e.g., indented portion) 578 can be formed along a depending wall 620, which laterally depends from cyclone sidewall 236. As exemplified in FIG. 129B, when the shroud 212 is translated downwardly to the axial height of grooved portion 578, the stopping structure 565 engages (e.g. abuts) the grooved portion 578, and the grooved portion 578 delimits further downward axial movement of the shroud 212.

Handle 440 of cleaning member has a narrower portion that extends through the gap 444 than stopping structure 565. Accordingly, as further exemplified FIG. 129B, upon engagement of the stopping structure 565 with the grooved portion 578, cleaning member 420 magnetically de-couples from magnets 569 on plate 562. The cleaning member 420 may be accordingly further translated into a cleaned position (FIGS. 129C and 129D) via handle 440, while the shroud 212 is retained in an intermediate cleaned position.

An advantage of this configuration is that the shroud 212 can be translated part-way into the cleaned position, so as to allow access to shroud 212 when door 352 is opened. Further, while the shroud 212 is retained in the intermediate cleaned position, the cleaning member 420 can continue de-bridging the exterior of the shroud 212 from dirt and debris, by translating axially along the shroud surface (FIGS. 129C-129D).

In other embodiments, rather than limiting axial movement of only the shroud 212, the stopping mechanism can delimit axial movement of both the cleaning member 420 and shroud 212. For example, in embodiments where the cleaning member 420 and shroud 212 are not detachably

68

connected, the shroud 212 and cleaning member 420 can translate concurrently. Stopping structure 565 can then engage grooved portion 578 to limit axial movement of the cleaning member 420 and shroud 212. Alternately, the portion of handle 440 that extends through the gap 444 may engage stopping structure 565. Alternately, a second stopping structure may be provided axially spaced from stopping structure 565 to limit the axial movement of cleaning member 420 after cleaning member has detached from shroud 212.

While the exemplified embodiments illustrate the stopping mechanism being used in conjunction with a handle 440, which extends through axial sidewall gap 444, it will be appreciated that, in other cases, the stopping mechanism can be applied to any of the previously exemplified driving assemblies. For example, where the handle assembly 436 does not extend through axial gap 444, the stopping structure 565 can be located inside the cyclone chamber 176, and can engage a grooved portion formed on the inner surface of the cyclone sidewall 236. For example, the driving assembly 436 can comprise a rod 438, which extends through the first or second cyclone ends. The rod can drivingly engage the cleaning member 420. In particular, the rod 438 can pass through shroud plate 562 (e.g., an opening in the shroud plate 562) to drivingly engage the cleaning member 420. In this configuration, the rod 438 can translate the shroud 212 and cleaning member 420, part way along the chamber's axial length. Once stopping structure 565 engages a grooved portion of sidewall 236, rod 438 can continue translating only the cleaning member 420.

Biassing Mechanism for Securing Cleaning Member and/or Shroud in Cyclone "Use" or Storage Position:

Optionally, irrespective of the driving assembly 436 used to translate the cleaning member 420 and/or shroud 212 from a storage position to one or more cleaned positions, a biasing mechanism can be provided to bias one or more of the cleaning member 420 and shroud 212 in a storage or cyclone "in-use" position. An advantage of the biasing mechanism is to prevent the cleaning member 420 and/or shroud 212 from collapsing inside the cyclone chamber 176, e.g., under gravitational force, during storage or cyclone use.

FIGS. 126-127 exemplify a first configuration for the biasing mechanism which uses magnets. In the exemplified configuration, one or more magnets 564 are disposed at the first cyclone end 240. As exemplified, magnets 564 may be secured inside retention members 568 (retention members 568 secure magnets 564 in position). As further exemplified, a plate 560 may be disposed over at least a portion of the cleaning member 420 which is directed to the first cyclone end 240. In the exemplified embodiment, plate 560 is formed, at least partially, from a magnetically attractable material (e.g., another magnet or a ferromagnetic material), which is attractable to magnets 564. In other embodiments, rather than providing a plate 560, all or a portion of the cleaning member 420, which is directed to the first cyclone end 240, and aligned with magnets 564, may be formed of magnetically attractable material.

As exemplified in FIG. 126A, the magnetic attraction between magnets 564 and plate 560 retains the cleaning member 420 in the storage or cyclone use position. When it is desired to translate the cleaning member 420 to one or more cleaned positions, an axial force is applied (e.g., by driving assembly 436) to de-couple magnets 564 from plate 560, and to allow translation of the cleaning member 420 to one or more cleaned positions (FIGS. 126B-126D). FIGS. 127A-127D exemplify a similar configuration where the shroud 212 is concurrently moveable with the cleaning

member **420**. In other cases, magnet biasing can also be used to bias only a moveable shroud **212**, in the storage or cyclone use position.

It will be appreciated that, in other embodiments, rather than using magnets **564**, a ferromagnetic material can be disposed at the first cyclone end **240**, and plate **560** (or a portion of the cleaning member **420**) may comprise a magnetic material. For example, magnets **564** may be provided on the cleaning member **420** or a plate **560** and the end wall of the cyclone chamber may be made of or provided with a magnetically attractable material.

FIGS. **133-134** exemplify another configuration for a biasing mechanism which comprise a spring. In the exemplified configuration, the biasing mechanism comprises a biasing spring **586**, which is biased to a compressed position (FIG. **133B**). As exemplified, spring **586** can be received within a hollow interior of a spring retention member **592**, provided at the first cyclone end **240**. In this configuration, spring **586** may be secured in position such as by being attached at a first end to a closed end **593** of retention member **592**, and may be attached at a second end to the cleaning member **420**. As exemplified in FIGS. **134A-134E**, as the cleaning member **420** is translated to a cleaned position, the spring **586** expands. Once handle **440** is released, the biased spring **586** retracts so as to automatically translate the cleaning member **420** back into the storage position. An advantage of this configuration is that the user is not required to manually return the cleaning member **420**, back to the storage position, after cleaning.

It will be appreciated that, in other embodiments, the configuration exemplified in FIGS. **133-134** can also be used to bias a moveable cleaning member **420** and shroud **212**, or a moveable shroud **212**, into the storage or cyclone use position.

FIGS. **162-163** exemplify still another configuration for a biasing spring. In the exemplified configuration, a spring **682**, which is biased in the compressed position (FIG. **162B**), is provided inside the cyclone chamber **176** and extends between the first cyclone end **240** and a plate **562**, attached around an axial outer end **212b** of shroud **212**. As exemplified in FIGS. **163B-163C**, as the shroud **212** is translated to a cleaned position, the spring **682** expands. Once handle **440** is released, the biased spring **682** may retract so as to automatically translate the shroud **212** back into the storage position.

It will be appreciated that, in other embodiments, the exemplified configuration in FIGS. **162-163** can also be used to bias a moveable cleaning member **420**, or the combination of a cleaning member **420** and shroud **212**, into the storage or cyclone use position.

Driving Assembly Re-Configurable Between Storage Position and Use Position:

Optionally, the driving assembly **436** can be re-configurable between a storage position, and a use or operating position, wherein in the use position, the driving assembly is drivingly connected to the cleaning member and/or shroud, and the cleaning member and/or shroud are in the storage position (for when the surface cleaning apparatus is used for cleaning). The driving assembly or handle may be pivotally moveable, telescopically moveable, translatably moveable or rotatably moveable between the use and storage positions. Alternately, or in addition, the driving assembly may be flexible so as to enable the assembly to be moved into a storage position.

FIGS. **109-110** exemplify a first embodiment for a re-configurable driving assembly **436** wherein the driving assembly comprises two pivotally connected portions. In the

exemplified configuration of FIG. **109**, the driving assembly **436** comprises an elongate member **438** which includes a first member portion **438₁** that is pivotally connected to a second member portion **438₂**, by hinge **490**. As exemplified, when the cleaning member **420** and/or shroud **212** are in the storage position (e.g., FIG. **105**), the first portion **438₁** can pivot relative to the second portion **438₂**, about pivot axis **491**, between a storage position (FIG. **109A**) and an extended use position (FIG. **109B**). As exemplified, in the storage position, the first portion **438₁** is recessed towards the cyclone sidewall **236**. In various cases, this allows the air treatment member **116** to be stowed away for storage in small or tight compartments, e.g., when the surface cleaning apparatus is in use or in placed in a closet for storage.

FIG. **110** exemplifies an alternative configuration in which the first member portion **438₁** is pivotally connected to the second member portion **438₂** by two hinges **490a**, **490b**. As exemplified, the hinges **490** may be interposed by a third member portion **438₃**. An advantage of this configuration is that, in the storage position (FIG. **110A**), the first member portion **438₁** is co-extensive with, may be located along side or spaced from and adjacent) the cyclone sidewall **236**. Accordingly, and in contrast to the configuration of FIG. **109A**, in which where the first member portion **438₁** is angled away from the cyclone sidewall **236**, the configuration of FIG. **110A** allows the air treatment member **116** to occupy less storage area when stowed away in small or tight compartments. This configuration also inhibits damage to the elongate member **438** when stowed away for storage by preventing the first member portion **438₁** from colliding with surrounding objects (e.g., because the member is not angled away from the cyclone chamber).

FIGS. **87-88** and **103** exemplify still another embodiment for a re-configurable driving assembly **436** which uses a telescoping member. Any telescoping structure may be used. Accordingly, the driving assembly may be reconfigured (telescoped) from a position in which a handle of the driving assembly is located at or proximate a surface of the surface cleaning apparatus (a storage position) to a position in which that driving assembly is operable to move the cleaning member and/or shroud (the operating position). An advantage of this design is that the driving member is less likely to be damaged when the surface cleaning apparatus is in use as the driving assembly (e.g., the handle) is retracted. This design may be used with any axially extending driving assembly disclosed herein.

In the exemplified embodiment (FIGS. **87** and **88**), the driving assembly **436** comprises an elongate member **438** which has a telescoping configuration to allow rod **438** to expand from a storage position to an extended use position.

In particular, as exemplified, the rod **438** can comprise a first portion **438₁** which telescopes over a second portion **438₂** (FIG. **87**), or a first portion **438₁** which telescopes inside a second portion **438₂** (FIG. **103**). The first portion **438₁** may collapse over or into the second portion **438₂**, to reduce the axial height **450** of the elongate member (e.g., FIGS. **87A** and **87E**) when the surface cleaning apparatus is in use. This may allow the air treatment member **116** to be stowed away for storage in small or tight compartments. The first portion **438₁** may also expand from the second portion **438₂**, to increase the axial height **450** of the elongate member (e.g., FIGS. **87B-87D** and **88**). This may allow the elongate member **438** to move the cleaning member **420** inside of the cyclone chamber over greater axial distances.

As exemplified, when the cleaning member **420** and/or shroud **212** are in the storage position (FIG. **87A**), the elongate member **438** may start from an initial retracted

storage position. The elongate member **438** may then be expanded to an in-use position (FIG. **87B**), and used to translate the cleaning member **420** and/or shroud **212** to one or more cleaned position (FIGS. **87C** and **88**). When it is desired to return the elongate member **438** back into the retracted storage position, the cleaning member **420** is first returned to the storage position (FIG. **87D**), and the elongate member **438** is then retracted back into the retracted storage position (FIG. **87E**).

In some cases, an activation mechanism (e.g., a button) can be provided to expand or retract the member **438**. The activation mechanism can be provided, for example, on the first end **438a** of the elongate member **438**.

As exemplified in FIG. **103**, the activation mechanism may comprise a rod **704**, which extends inside the hollowed interior of the first elongate member **438₁**. The rod **704** can include a depressible button **702**, at a first end **704a**, and a catch member **706**, at a second **704b**, wherein the catch member **706** is configured as an 'inverted fork'.

To expand the elongate member **438**, button **702** is depressed downwardly, along translation axis **428** (FIG. **103B**). This allows catch fork **706** to engage an oblong lock structure **708**. The oblong lock structure **708** comprises two rib members **708a**, **708b**, joined at their distal ends. The oblong structure **708** is compressible, and is biased into an expanded position (FIG. **103A**).

As exemplified in FIG. **103A**, pegs **710a**, **710b** extend outwardly from each rib **708**. In the storage position (FIG. **103A**), pegs **710** are inserted into openings, located along the first elongate member **438₁**, and second elongate member **438₂**. More specifically, a pair of openings **712a**, **712b** are formed along the first member **438₁** to receive pegs **710**. A second pair of openings **714a**, **714b** are formed along the second member **438₂**, to also receive pegs **710**. In the storage position, openings **712** and **714** are aligned along a common axis. In particular, this allows pegs **710a**, **710b** to insert into both openings **712a**, **714a** and **712b**, **714b**, respectively, and to lock relative movement of the first elongate member **438₁** to the second elongate member **438₂**.

As exemplified in FIG. **103B**, once the oblong lock **708** is compressed by fork **706**, pegs **710** are displaced, at least, from openings **714** (e.g., formed on the second elongate member **438₂**). This permits relative movement of first member **438₁** to the second member **438₂**. The first member **438₁** may then extend until openings **712** and **714** are misaligned (FIG. **103C**). Once openings **712**, **714** are misaligned, button **702** may be released (FIG. **103D**), to disengage fork **706** from lock structure **708**, and to allow the oblong structure **708** to re-expand.

As exemplified in FIG. **103E**, the first member **438₁** is extended until openings **712**, of the first member **438₁**, re-align with a secondary set of openings **716**, provided on the second member **438₂**. Once openings **712** and **716** align, the oblong structure **708** automatically re-expands to force pegs **710** through secondary openings **716**. Accordingly, this generates a locking engagement between members **438₁**, **438₂** in the expanded use position (FIG. **87B**).

If it is desired to re-retract the handle assembly **436** (FIG. **87E**), the button **702** is again depressed to engage fork **706** with oblong structure **708**, and re-compress the oblong structure **708**. This, in turn, displaces pegs **710** from openings **716**, and allows for relative movement of member **438₁** to member **438₂**. The elongate member **438** can then be retracted into the storage position.

It will be appreciated that while two pegs **710** have been exemplified, the oblong member **708** may include any

number of pegs, and the elongate members **438** may include any number of corresponding openings (**712**, **714** and **716**) to receive pegs **710**.

Optionally, a biasing mechanism is provided to bias the activation mechanism **702** (e.g., button **702**) in the undepressed state (e.g., FIGS. **103A**, **103D-103E**). As exemplified, the biasing mechanism can comprise a biasing spring **718**. The spring **718** is provided inside of a chamber **720**, located within the first member **438₁** (e.g., proximal the first end **438a** of the elongate member **438**). An interior wall **722**, of chamber **720**, includes an opening **724** to accommodate rod **704**. As exemplified, spring **718** is biased in the expanded position (FIG. **103A**). In this configuration, an axial force is required to depress the button **702**, and compress the spring **718**. Once the button **702** is depressed and then released, the spring **718** automatically expands to push the button **702** axially upwardly into the initial undepressed position. In this manner, a user is not required to manually extract the button after the button has been depressed inwardly.

It will be appreciated that other telescoping locking systems may be used which do not require the use of a button **702**. Any telescoping locking system known in the art may be used.

FIGS. **161A-161D** exemplify for the use of a telescoping driving assembly **436** for moving a shroud. In the exemplified embodiment, the driving assembly **436** comprises a telescoping elongate member **438**. The elongate member **438** is re-configurable between a retracted storage position (FIG. **161B**) and an expanded use position (FIG. **161C**). In particular, as exemplified, in the storage position, a second elongate member **438₂** is nested within a first elongate member **438₁**. A portion of the first elongate member **438₁** extends outside the cyclone chamber **176**. The second end **438b₂**, of the second elongate member **438₂**, is attached to shroud **212**. As exemplified in FIG. **161C**, the first member **438₁** may telescope, axially outwardly (e.g., along translation axis **232**) into a use position. Optionally, a lock structure **708** is provided to limit the axial extension of the first member **438₁**, relative to the second member **438₂**. The lock structure **708** may operate similar to the oblong structure **708** exemplified in FIG. **103**. As exemplified in FIG. **161D**, in the expanded position, the elongate member **438** can be used to translate shroud **212** into a cleaned position.

As exemplified in FIGS. **157-160** a re-configurable handle assembly **436** which uses a flexible Bowden cable. As previously discussed, the driving assembly **436** comprises a flexible (or partially flexible material) elongate member **438**. As exemplified, the handle assembly **436** may bend between a storage position (FIGS. **157** and **159**), where the elongate member **438** is positioned adjacent the cyclone sidewall **236**, and an expanded use position (FIGS. **158** and **160**). In the storage position, the air treatment member **116** can be stowed away in small or tight compartments. In some cases, the member can be biased to the extended use position.

FIGS. **162-163** exemplify a further embodiment for a re-configurable handle assembly **436** wherein the handle **440** is translatable. In the exemplified embodiment, the driving assembly **436** comprises a handle **440**, drivingly engaged to a moveable shroud **212**, through an axial gap **444**. The axial gap **444** comprises a first lateral portion **692a**, proximal the first gap end **444a**, and a second laterally extending portion **692b**, proximal the second gap end **444b**. The first and second lateral portions **692** are separate, for example, by a portion of the cyclone sidewall **236**.

In the storage position, the handle **440** is disposed inside the first lateral gap **692a** (FIG. **162A**). The handle **440** is

translated into a “use” position by laterally or radially translating the handle **440**, out of the lateral gap **692a**, and into the axial gap **444** (FIG. **163A**). In various cases, this can also cause the shroud **212** to rotate inside the chamber **176** (i.e., as the handle **440** is translated laterally). Optionally, as exemplified in FIG. **163D**, once the shroud **212** is in the cleaned position, the handle **440** can again be translated into the second lateral gap **692b**, to retain the shroud **212** in the cleaned position. It will be appreciated that only one lateral gap **692a**, lateral gap **692b**, may be provided.

In other embodiments, rather than being drivingly engaged to shroud **212**, the handle **440** can be drivingly engaged to a cleaning member **420**, or the combination of a cleaning member **420** and an attached shroud **212**.

In a further optional embodiment, the handle **440** may be rotatable to a storage position. For example, as discussed in more detail subsequently, rod **438** shown in FIGS. **87A-87E** may be rotatable about its longitudinal axis so as to enable handle **440** to be rotated between an in use and a storage position (see for example FIG. **94B**). In the storage position, the handle **440** may be positioned adjacent a portion, e.g., of the cyclone assembly and, optionally may be prevented from moving axially by seating on resting member **504**. The handle may be rotated away from the storage position to an in use position (see FIG. **95B**) in which the handle is no longer seated on resting member **504** and is axially moveable.

Handle Assembly Extending Along a Portion of Air Treatment Member

Optionally, the driving assembly **436** can extend along (adjacent) a portion of the air treatment member **116**. An advantage of this configuration is that the driving assembly **436** does not need to be re-configured from an in-use position to a storage position in-order to stow away the air treatment member **116** for storage. Further, this configuration can also prevent damage to the handle assembly **436** during storage or use, as the driving assembly **436** is protected by a portion of the treatment member **116**.

FIGS. **89A-89B** exemplify a first configuration for a driving assembly **436** which extends along a portion of the air treatment member **116**. As exemplified, the air treatment member **116** comprises a first cyclonic stage **168**, positioned over a second cyclonic stage **168**₂. The driving assembly **436** comprises an elongate member **438** drivingly engaged to a cleaning member **420** and/or shroud **212** inside the second cyclonic stage **168**₂. As exemplified, the elongate member **438** extends parallel to each of the first and second cyclonic stage **168** (e.g., the rod **438** is co-extensive with the cyclonic stages). Accordingly, in this configuration, the elongate member **438** can translate the cleaning member **420** and/or shroud **212** between the storage position (FIG. **89A**) and one or more cleaned positions (FIG. **89B**), without deployment (e.g., re-configuring the elongate member **438** from a storage position to an extended use position).

FIG. **111** exemplifies another configuration for a handle assembly **436** which extends along a portion of the air treatment member **116**. In the exemplified configuration, the driving assembly **436** comprises an elongate member **438**, and the elongate member **438** extends parallel to, and is co-extensive with, the external dirt chamber **172**. In the exemplified embodiment, the external dirt chamber **172** has an axial length which is greater than the cyclone chamber **176**. Optionally, as exemplified, the external chamber **172** has an axial length which is substantially equal to the axial length of the elongate rod **438**, when the rod **438** is configured in the storage position.

In various cases, as exemplified in FIG. **94**, where the driving assembly **436** extends along a portion of the air treatment member **116**, a handle **440** of the driving assembly **436** may be configurable to move (e.g., rotate) between a storage position (e.g., FIG. **94**) and an in-use position (e.g., FIG. **95**), about translation axis **428**. In the storage position, the handle **440** is recessed toward the cyclone unit **170**. Optionally, a resting member **504** is located on a track **430** to receive (e.g., rest) the handle **440** in the storage position. Preferably, the resting member **504** is positioned such that when the handle **440** is rested thereon, the cleaning member **420** is also positioned in the storage position (e.g., proximal the first cyclone end). The resting member may protect the handle from being accidentally actuated while the surface cleaning apparatus is in use. The handle may accordingly be moved outwardly into an in-use position (e.g., FIG. **95**), whereby the handle **440** is usable to axially move the handle assembly. In various cases, where the handle assembly **436** comprises an elongate member **438** which travels through a track **430**, an axial gap may extend axially along the track **430** to accommodate axial movement of the handle **430** (e.g., axial gap **447** in FIG. **118D**).

While the exemplified embodiments have illustrated the driving assembly **436** is extending along one or more cyclonic stages, or an external dirt chamber, it will be appreciated that, in other embodiments, the driving assembly **436** may extend along, and be co-extensive with, any other portion of the air treatment member **116** or a surface cleaning apparatus. For example, in other cases, the driving assembly **436** may be co-extensive with the suction motor housing **164**.

Alternative Cleaning Mechanisms

FIGS. **164-166** exemplify other embodiments for cleaning, at least, the shroud **212**. In these embodiments, the shroud is removed via the outlet end of the cyclone chamber to enable the shroud to be cleaned.

As exemplified, shroud **212** is attached (e.g., integrally or detachably) to a lid **562**. As exemplified, lid **562** can surround the axial outer end **212b** of the shroud **212**. The lid **562** is located axially above the first cyclone end **240** (e.g., assuming the cyclone **170** is in an upright position), which is the air outlet end of the cyclone chamber. As exemplified, in this configuration, the lid **560** can be used to pull the shroud **212** from a storage or use position (FIGS. **164B**, **165A** and **166B**), in which the shroud **212** is located inside the cyclone chamber, to a cleaned position (FIGS. **164C**, **165B** and **166C**), in which the shroud **212** is disposed outside the cyclone chamber **176**.

Optionally, as exemplified in FIG. **166**, a handle **440** can be attached (e.g., integrally molded or detachably connected) to lid **562**, to facilitate pulling the shroud **212** out of the cyclone chamber. Optionally, an elongate member **438** may depend from the handle **440**, and can be receivable inside an external track **430**, located adjacent the cyclone **170**. In various cases, insertion of the elongate member **438** inside the track **430** can help secure the shroud **212** inside the cyclone **170** in the storage or use position.

Optionally, as exemplified in FIGS. **164-165**, a biasing mechanism can be provided to bias the shroud **212** into the cleaned position. In the exemplified embodiment, the biasing mechanism comprises a spring **682**, which is biased in an expanded state (e.g., a compression spring). As exemplified, the lid **562** may be spaced from the first cyclone end **240**, and a sidewall **563** may depend axially from the lid **562**, and extend to the first cyclone end **240** when the lid **562** is in the closed position. The biasing spring **682** may be provided between the lid **562** and the first cyclone end **240**.

As exemplified, a latch **674** can secure the lid **562** in the closed position (FIGS. **164B** and **165A**), and hold the spring **682** in the compressed position. Latch **674** may be rotatably secured to the cyclone sidewall **236** by a hinge **814**. When the latch **674** is rotated away (e.g., about pivot axis **814a**), the spring **682** may automatically expand to push the shroud **212** into the cleaned position (FIGS. **164C** and **165B**).

Door Lock Mechanism

Optionally, in any of the embodiments discussed herein, a door locking mechanism may be provided to lock or unlock a bottom openable door **352** of the cyclone **170**. The door lock may secure the door **352** in the closed position during storage or use of the air treatment member **116**. The door lock may also be unlocked to enable a door (e.g., an end wall of the cyclone) to open to thereby permit the dirt collection chamber **172** and/or cyclone chamber **176** to be emptied, as well as to provide access to the cleaning member **420** and/or shroud **212**. The door locking mechanism may be actuated (e.g., moved to the unlocked position) by movement of the handle **440** or the driving assembly to a cleaned position.

FIGS. **121-122** exemplify an embodiment of a door locking mechanism **486** which is positioned axially spaced from and aligned with a driving rod **438** that forms part of the driving assembly so as to be engageable by the driving rod **438**. As exemplified, the driving rod **438** may depend axially from the handle **440**.

As exemplified, the locking mechanism **486** comprises a first lock member **530** and a second lock member **534**. As best exemplified in FIG. **122A**, each lock member includes a respective first end **530a**, **534b** and a respective opposed second end **530b**, **534b**.

Optionally, the first end **530a**, of the first lock member **530**, can comprise a concave surface (e.g., a cup shaped surface). The concave surface engages the second end **438b** of the elongate member **438** when the elongate member **438** is translated axially downwardly toward the second cyclone end **244** (e.g., assuming the cyclone is in an upright position).

As exemplified, the second end **530b**, of the first lock member **530**, is pivotally joined to the second lock member **534** (e.g., the first end **534a** of the second lock member **534**). In the exemplified embodiment, the first lock member **530** is configured as a "V" shaped member, which pivots about pivot point **536**.

The second end **534b**, of the second lock member **534**, is slidably received inside of slot **542**, disposed on a first depending portion **540** of door **352**. Second end **534b** is also slidably received inside slot **538**, disposed on a second depending portion **236a** of cyclone sidewall **236**.

In the locked position (FIG. **122A**), slots **538**, **542** are substantially axially aligned, and the second lock member **534** extends through each slot **538**, **542**. In this configuration, the second lock member **534** prevents opening of door **352**.

When it is desired to open door **352**, the second end **438b**, of the elongate member **438**, engages (i.e., applies an axial downward force) to the cup-shaped end **530a**, of the first lock member **530**. This, in turn, pivots the first lock member **530** about pivot point **536**. As the first lock member **530** pivots, it urges the second lock member **534** upwardly (e.g., through a pivotal connection). In particular, as the second lock member **534** is urged axially upwardly, second lock member **534** is slidably removed (e.g., radially inwardly) from slot **538** (on cyclone sidewall **236a**), and unlocks door **352**. In this manner, the door **352** is able to rotate into the open position (FIG. **122B**).

FIGS. **123-124** exemplify another embodiment for a door locking mechanism **486** which is also engageable by a driving rod **438** that forms part of the driving assembly.

In the exemplified embodiment, the cyclone **170** comprises an openable first sidewall portion **248**. As exemplified, the unlocking mechanism **486** comprises a flexible member **612**, which depends from the first sidewall portion **248**. The flexible member **612** comprises a first end **612a** and a second end **612b**, wherein the second end **612b** is disposed axially above the first end **612a** (e.g., assuming the air treatment member **116** is in the upright position). In the exemplified embodiment, the first end **612a** is attached (e.g., integrally molded) to the first sidewall portion **248**. The second end **612b** comprises a hook-shaped formation, formed from a first lateral surface **614**, and a second slanted lateral surface **616**, wherein the second lateral surface **616** is located axially above the first surface **614**.

In the locked position (FIGS. **123B** and **124B**), the first lateral surface **614** rests on a flange **618** (e.g., rib or peg), which extends outwardly from the second cyclone sidewall portion **252**. Accordingly, sidewall portion **248** is held in the closed position by engagement of the lateral surface **614** on the flange **618**.

To unlock the lock mechanism **486**, the second end **438b**, of the elongate member **438**, is translated toward the second cyclone end **244**, and applies an axial downward force to the slanted surface **616**. This, in turn, compresses (i.e., forces downwardly) the slanted surface **616**, and causes the lateral surface **614** to displace from the flange **618**. Accordingly, this allows the first sidewall portion **248** to rotate with respect to the second sidewall portion **252**. The elongate rod **438** may unlock the locking mechanism **486**, and further push the sidewall portion **248** into the open position by continuing to applying an axial force to the slanted surface **616**.

While the lock mechanism **486** in FIGS. **123-124** has been exemplified with respect to a sidewall **236** having an openable sidewall portion, it will be appreciated that the same lock configuration can be applied to secure, e.g., a bottom openable door **352** in the closed position. For example, the first end **612a** of the flexible member **612** may be attached (e.g., integrally molded) to a portion of door **352**, and the flange **618** may extend from the cyclone sidewall **236**.

In other embodiments, the driving rod **328** may not actuate a door locking mechanism **486**, but rather, may simply push the bottom door **352** into the open position. For instance, as exemplified in FIGS. **93A-93C**, the door **352** may extend to at least partially underlie the driving rod **438** (or track **430**). In this configuration, the driving rod **438** is translated toward the second cyclone end **244**, and the second end **438b**, of the elongate rod **438**, engages the door **352**, and pushes the door **352** into the open position. Such a design may be used, e.g., with a manually openable door.

FIGS. **106-108** exemplify still another configuration for a door locking mechanism **486** in which the cleaning member **420** and/or the screen **212** may be used for unlocking the openable door **352**.

In the exemplified embodiment, and as best exemplified in FIG. **107**, the openable door **352** is retained in the closed position by a lock member **498**. The lock member **498** includes a first end **498a** and an axially opposed second end **498b**. The second end **498b** holds the door in the locked position by extending through opening **542** on depending portion **540**, and opening **538**, on depending sidewall portion **236a**.

As exemplified, a peg **806** is disposed on a lower surface (e.g., face), of the cleaning member **420**, which faces the

second cyclone end **244**. As exemplified in FIG. **107A**, upon translating cleaning member **240** toward the second cyclone end **244**, peg **806** is receivable inside of a small opening **808**, formed through the second cyclone end **244**, and engages an optional flexible seal member **488**. Upon engagement, the peg **806** deforms the seal member **488**, and causes the seal member **488** to engage an activation mechanism **492**. In the exemplified embodiment, the activation mechanism **492** comprises an electronic sensor (e.g., a pressure sensor), which is activated when engaged by the flexible seal **488**. Once activated, the electrical sensor **492** transmits an electrical signal, via wire **496**, to a motor unit **494**. The activated motor unit **494** pulls (e.g., draws) the locking member **498** out of the opening **538**, to unlock the door **352**. When it is desired to re-lock the door **352**, the locking member **498** may be, for example, manually re-inserted into openings **538**, **542** while the door **352** is in the closed position. It will be appreciated that peg **806** may alternately mechanically engage and actuate the locking mechanism.

FIG. **108** exemplifies a similar configuration where door **352** is unlocked by screen **212**. In the exemplified configuration, the cleaning member **420** and screen **212** are translated concurrently through the cyclone chamber **176**. As exemplified, the screen **212** includes a peg **806**, disposed on an axial inward surface **212a** of the screen **212**. When the screen **212** is translated to the second cyclone end **244**, peg **806** extends through the opening **808**, and activates the activation mechanism **492** to unlock door **352**. In other cases, peg **806** may be provided at different locations along the screen **212**. For example, peg **806** may be located (or formed) on cleaning prongs **462**, which axially depend from screen **212** (FIG. **90C**). In these cases, the prongs **462** can have a greater axial length than shroud **212** to engage the locking mechanism before shroud **212** engages the second cyclone end **244**.

It will be appreciated that the configuration exemplified in FIG. **108** can also be used where a cleaning member **420** is not provided, and the cyclone comprises only a moveable shroud **212**. It will also be appreciated that, in other embodiments, the driving rod **438** can extend beyond the cleaning member **420** and/or shroud **212**, and the peg **806** can be disposed at an axially inward end **438b** of the driving rod **438**. For example, the cleaning member **420** and/or shroud **212** may attach to a mid-portion of the driving rod, rather than to the second end **438b** (as exemplified), such that the driving rod **438** can extend beyond the cleaning member **420** and/or shroud **212**. In particular, in this configuration, the driving rod **438** can be used to unlock the lock mechanism **436** from inside the cyclone chamber **176**.

FIG. **164** exemplifies another embodiment for a door locking mechanism wherein the actuator is not part of the handle **440** or the driving mechanism.

As exemplified in FIG. **164**, a first latch **672** is provided to secure the door **352** in the closed position. In the exemplified embodiment, latch **672** is rotatably secured to the cyclone sidewall **236**, proximal the second cyclone end **244**, by hinge **812**. As exemplified in FIG. **164B**, latch **672** includes a slot **672a**, which receives a flange **816** extending from door **352**. A second latch **674** is also provided, proximal the first cyclone end **240**, and is used to secure the lid **562**. The first and second latches **672**, **674** are connected to each other by a retraction rod **684**.

As exemplified in FIG. **164C**, when the second latch **674** is rotated away from the cyclone **170** to release lid **562**, the retraction rod **684** causes the first latch **672** to also rotate away, along rotation axis **812a**. In this manner, the door **352** is opened concurrently with release of the top lid **562**.

It will be appreciated that while the exemplified locking mechanisms have been illustrated with respect to an openable door **352**, provided at the second cyclone end **244**, similar locking mechanisms can be used to lock a top openable door **390**, provided at the first cyclone end **240** (e.g., in cases where the cyclone **170** is an inverted cyclone).

It will also be appreciated that any locking mechanism known in the vacuum cleaner arts may be used and that the locking mechanism may be directly engagable and actuable by the handle **440** itself, the driving mechanism, the cleaning member and/or the shroud.

While the above description provides examples of the embodiments, it will be appreciated that some features and/or functions of the described embodiments are susceptible to modification without departing from the spirit and principles of operation of the described embodiments. Accordingly, what has been described above has been intended to be illustrative of the invention and non-limiting and it will be understood by persons skilled in the art that other variants and modifications may be made without departing from the scope of the invention as defined in the claims appended hereto. The scope of the claims should not be limited by the preferred embodiments and examples, but should be given the broadest interpretation consistent with the description as a whole.

The invention claimed is:

1. A vacuum cleaner or extractor comprising:

- (a) an air flow path extending from a dirty air inlet to a clean air outlet;
- (b) an air treatment member having an air treatment chamber positioned in the air flow path, the air treatment chamber comprising an air treatment chamber air inlet, an air treatment chamber air outlet, an openable first end, a longitudinally spaced apart second end having the air treatment chamber air outlet and a longitudinally extending sidewall, wherein the air treatment chamber air outlet comprises a longitudinally extending porous member having a longitudinally extending porous sidewall;
- (c) a suction motor positioned in the air flow path upstream of the clean air outlet;
- (d) a moveable member positioned in the air treatment chamber, the moveable member comprising at least one of the porous member and a cleaning member positioned in the air treatment chamber between the sidewall of the air treatment chamber and the porous sidewall; and,
- (e) a driving assembly comprising a handle and a driving linkage wherein the driving assembly is reconfigurable between a stored position in which the moveable member is in a storage position and an operable position in which the moveable member is translatable through at least a portion of the chamber, wherein when the driving assembly is in the operable position, the driving linkage consisting of a single longitudinally extending driving member which is connected to the moveable member, whereby, when the driving assembly is in the operable position, the driving assembly is operable to longitudinally translate the moveable member through at least a portion of the chamber.

2. The vacuum cleaner or extractor of claim 1 wherein the extendable member comprises a rotatably mounted drive rod, the rotatably mounted drive rod has a longitudinal axis and the rotatably mounted drive rod is rotatably mounted about an axis that extends in a plane that is transverse to the longitudinal axis of the drive rod.

3. The vacuum cleaner or extractor of claim 2 wherein the driving linkage comprises a longitudinally translatable drive rod and the rotatably mounted drive rod is rotatably mounted to the longitudinally translatable drive rod.

4. The vacuum cleaner or extractor of claim 1 wherein a portion of the driving linkage is exterior to the air treatment chamber and in the stored position, the portion of the driving linkage is recessed against a portion of the vacuum cleaner or extractor.

5. The vacuum cleaner or extractor of claim 4 wherein, in the stored position, the portion of the driving linkage is coextensive with a portion of the air treatment member.

6. The vacuum cleaner or extractor of claim 1 wherein the handle is rotatably mounted and in the stored position, the handle is recessed against a portion of the vacuum cleaner or extractor and in the operable position the handle is positioned away from the portion of the vacuum cleaner or extractor.

7. The vacuum cleaner or extractor of claim 6 wherein, in the stored position, the handle abuts the portion of the vacuum cleaner or extractor.

8. The vacuum cleaner or extractor of claim 6 wherein the driving linkage comprises a longitudinally extending drive rod having a drive rod axis and the handle is rotatable about the drive rod axis.

9. The vacuum cleaner or extractor of claim 1 further comprising a stop member operably engageable with the driving assembly to inhibit the driving assembly moving to the operable position.

10. The vacuum cleaner or extractor of claim 1 wherein the moveable member is moveable from an operating position in which the moveable member is positioned towards the second end and a cleaned position in which the moveable member is translated longitudinally away from the second end.

11. The vacuum cleaner or extractor of claim 10 wherein in the cleaned position, at least a portion of the moveable member is exterior of the air treatment chamber.

12. The vacuum cleaner or extractor of claim 1 wherein the moveable member comprises the cleaning member and the cleaning member is moveable from an operating position in which the cleaning member abuts the second end and a cleaned position in which the moveable member is translated longitudinally away from the second end.

13. The vacuum cleaner or extractor of claim 1 wherein the cleaning member comprises an annular member.

14. The vacuum cleaner or extractor of claim 1 wherein the handle has a first end and an opposed second end and the driving linkage is connected to the handle at only the first end of the handle.

15. The vacuum cleaner or extractor of claim 1 wherein the driving linkage comprises an extendable member wherein, in the stored position, the extendable member is in a contracted configuration and, in the operable position, the extendable member is in an extended configuration in which the handle is operable to longitudinally translate the moveable member through at least a portion of the chamber.

16. The vacuum cleaner or extractor of claim 15 wherein the driving linkage is drivingly connected to the moveable member when the extendable member is in the contracted configuration.

17. The vacuum cleaner or extractor of claim 15 wherein the extendable member comprises a telescoping drive rod.

18. The vacuum cleaner or extractor of claim 15 wherein the extendable member is exterior to the air treatment chamber and in the contracted configuration, the extendable member is recessed against a portion of the vacuum cleaner or extractor.

19. The vacuum cleaner or extractor of claim 18 wherein, in the contracted configuration, the extendable member is coextensive with a portion of the air treatment member.

20. The vacuum cleaner or extractor of claim 15 wherein the extendable member has the handle and, in the extended configuration, the handle is longitudinally spaced from the first and second ends of the air treatment chamber.

* * * * *