



(12) **United States Patent**
Conrad

(10) **Patent No.:** **US 10,357,136 B2**
(45) **Date of Patent:** **Jul. 23, 2019**

(54) **ALL IN THE HEAD SURFACE CLEANING APPARATUS**

(71) Applicant: **Omachron Intellectual Property Inc.**, Hampton (CA)

(72) Inventor: **Wayne Ernest Conrad**, Hampton (CA)

(73) Assignee: **Omachron Intellectual Property Inc.**, Hampton, Ontario (CA)

(*) Notice: Subject to any disclaimer, the term of this patent is extended or adjusted under 35 U.S.C. 154(b) by 383 days.

(21) Appl. No.: **15/254,072**

(22) Filed: **Sep. 1, 2016**

(65) **Prior Publication Data**
US 2016/0367092 A1 Dec. 22, 2016

Related U.S. Application Data

(63) Continuation-in-part of application No. 14/829,331, filed on Aug. 18, 2015, now Pat. No. 10,022,027, (Continued)

(51) **Int. Cl.**
A47L 5/22 (2006.01)
A47L 5/30 (2006.01)
A47L 9/04 (2006.01)
A47L 9/16 (2006.01)
B25G 1/04 (2006.01)
(Continued)

(52) **U.S. Cl.**
CPC *A47L 9/322* (2013.01); *A47L 5/225* (2013.01); *A47L 5/30* (2013.01); *A47L 9/0018* (2013.01); *A47L 9/0411* (2013.01); *A47L 9/16* (2013.01); *A47L 9/1608* (2013.01); *A47L 9/1683* (2013.01); *A47L 9/1691* (2013.01);
(Continued)

(58) **Field of Classification Search**
CPC *A47L 9/322*; *A47L 9/1691*; *A47L 9/0411*; *A47L 9/0018*; *A47L 5/225*; *A47L 9/16*; *A47L 5/30*; *A47L 9/2878*; *A47L 9/325*; *A47L 9/1683*; *A47L 9/1608*; *A47L 5/22*; *B25G 1/04*
See application file for complete search history.

(56) **References Cited**
U.S. PATENT DOCUMENTS
5,309,600 A * 5/1994 Weaver *A47L 5/00* 15/323
5,500,979 A 3/1996 Worwag
(Continued)

FOREIGN PATENT DOCUMENTS
CA 2192906 7/1997
CA 2192909 7/1997
(Continued)

OTHER PUBLICATIONS
International Search Report and Written Opinion, International Application No. PCT/CA2015/051331, dated Mar. 3, 2016.
Primary Examiner — David Redding
(74) *Attorney, Agent, or Firm* — Philip C. Mendes da Costa; Bereskin & Parr LLP/S.E.N.C.R.L., s.r.l.

(57) **ABSTRACT**
An all in the head surface cleaning apparatus may include a surface cleaning head and a portable cleaning unit comprising an air treatment member and a suction motor that is removably mounted to the surface cleaning head. An upper portion may be moveably mounted to the surface cleaning head between a storage position and a floor cleaning position, the upper portion comprising a drive handle.

24 Claims, 11 Drawing Sheets

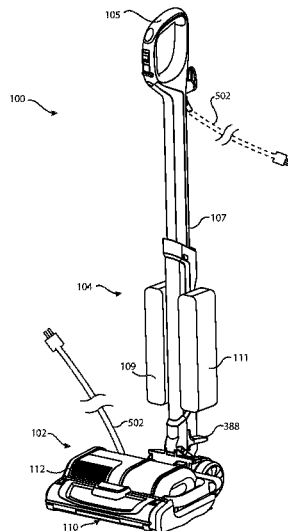

Related U.S. Application Data

which is a continuation of application No. 14/573,549, filed on Dec. 17, 2014, now Pat. No. 9,717,383.

(51) **Int. Cl.**

A47L 9/00 (2006.01)
A47L 9/28 (2006.01)
A47L 9/32 (2006.01)

(52) **U.S. Cl.**

CPC *A47L 9/2878* (2013.01); *A47L 9/325* (2013.01); *B25G 1/04* (2013.01)

(56) **References Cited**

U.S. PATENT DOCUMENTS

5,671,499 A 9/1997 Melito et al.
 5,699,586 A 12/1997 Melito et al.
 5,765,258 A 6/1998 Melito et al.
 5,909,755 A 6/1999 Leal
 6,012,200 A 1/2000 Murphy et al.
 6,221,134 B1 4/2001 Conrad
 6,317,920 B1 11/2001 Brickner et al.
 6,345,411 B1 2/2002 Kato
 6,442,792 B1 9/2002 Sudou et al.
 6,817,059 B2 11/2004 Tsuchiya
 D507,387 S 7/2005 Jacobs
 7,013,528 B2 3/2006 Parker et al.
 7,222,393 B2 5/2007 Kaffenberger
 7,251,854 B2 8/2007 Gerth et al.

7,329,294 B2 2/2008 Conrad
 7,996,957 B2 8/2011 Kah, Jr.
 8,020,251 B2 9/2011 Luebbering et al.
 8,268,029 B2 9/2012 Yoo
 9,119,511 B2 9/2015 Kah
 2004/0134026 A1 7/2004 Brinkhoff et al.
 2005/0115409 A1 6/2005 Conrad
 2006/0156509 A1 7/2006 Luebbering et al.
 2006/0196004 A1 9/2006 Conrad
 2006/0288520 A1 12/2006 Oh
 2008/0178420 A1 7/2008 Conrad
 2009/0056060 A1 3/2009 Han et al.
 2010/0229337 A1 9/2010 Conrad
 2013/0291333 A1 11/2013 Grey
 2014/0165313 A1 6/2014 Hicke
 2014/0237753 A1 8/2014 Conrad
 2014/0245564 A1 9/2014 Conrad
 2015/0135474 A1 5/2015 Gidwell

FOREIGN PATENT DOCUMENTS

CA 2192883 12/1997
 CA 2276796 1/2000
 CA 2374961 11/2001
 CA 2391177 12/2002
 CA 2391180 12/2002
 CA 2603508 10/2006
 CA 2706562 5/2009
 CA 2806339 2/2012
 CA 2821234 6/2012
 GB 2419276 B 8/2007

* cited by examiner

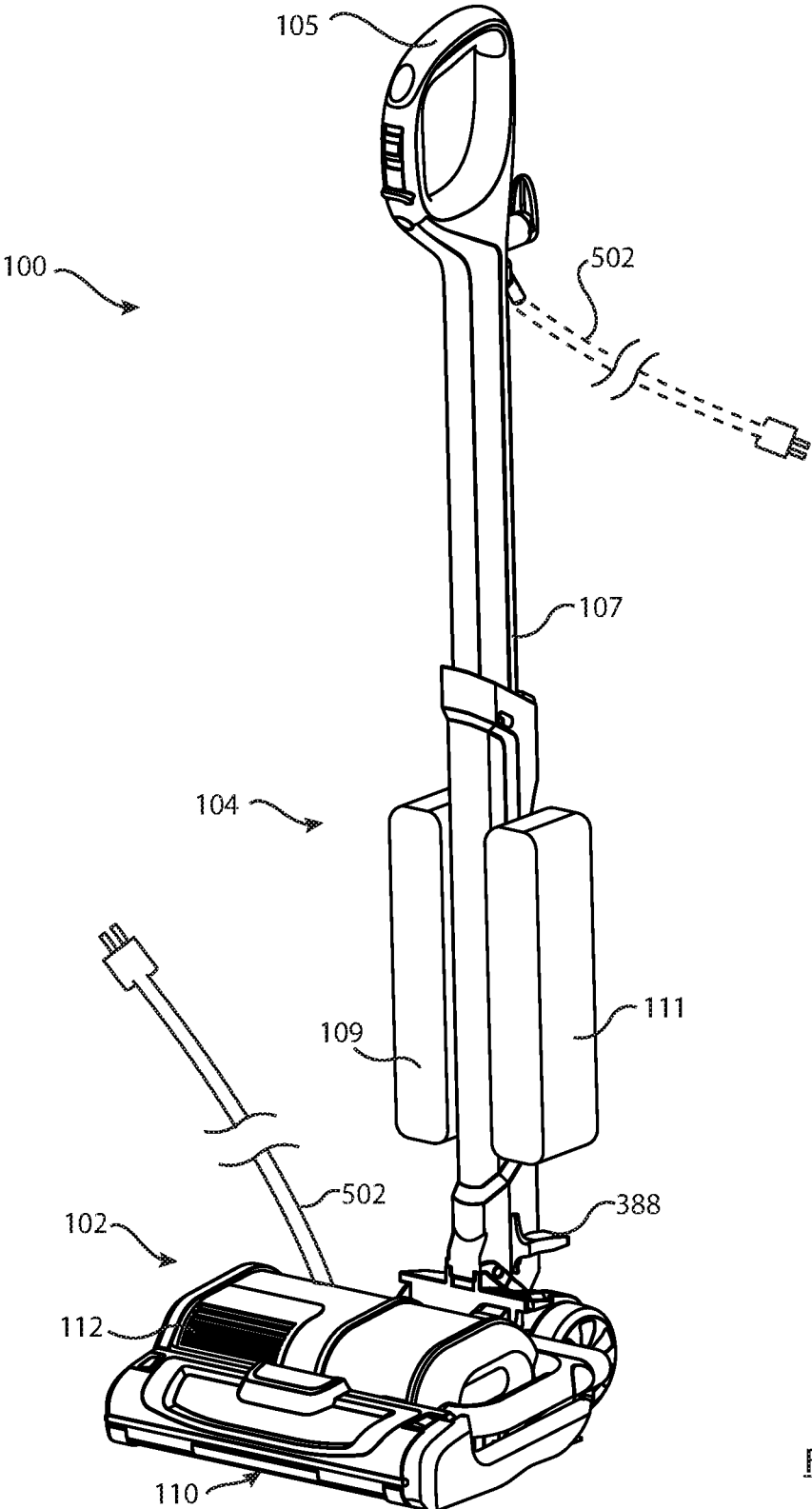

FIG. 1

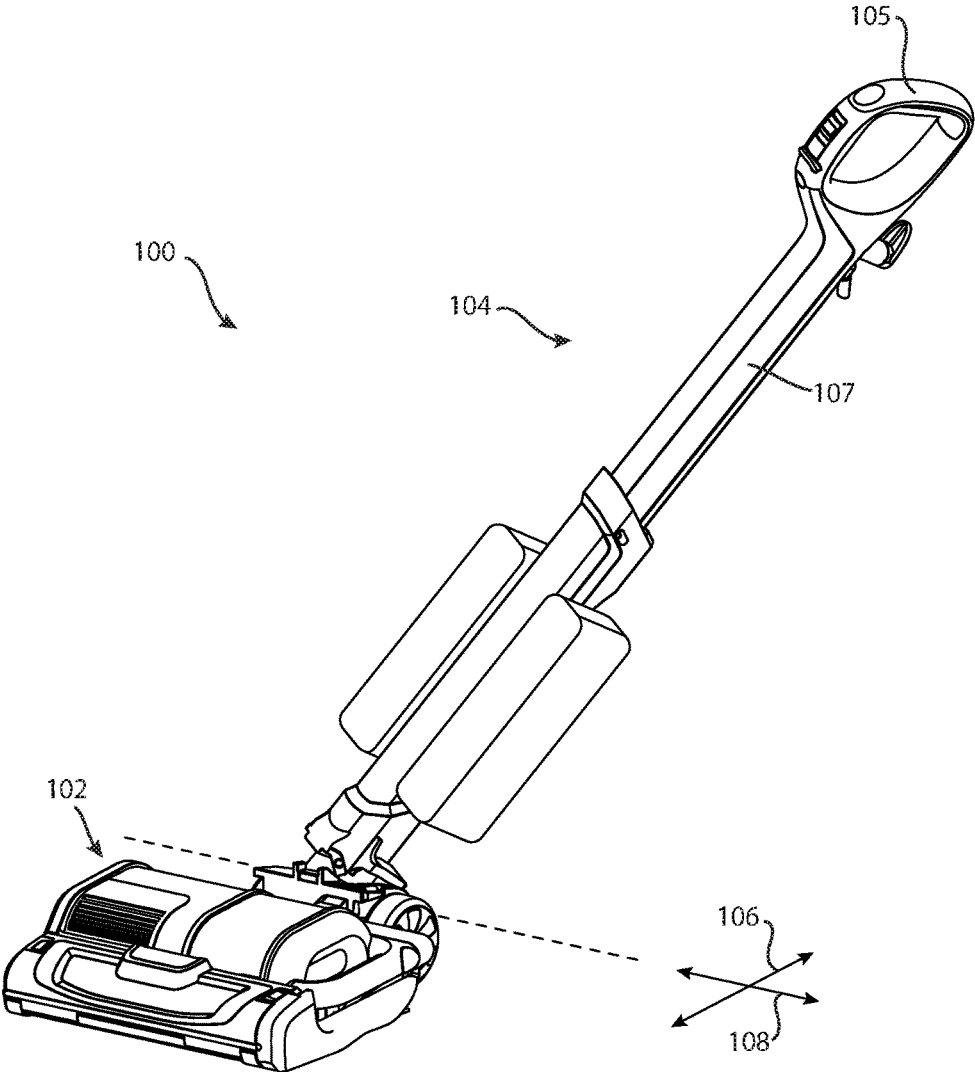

FIG. 2

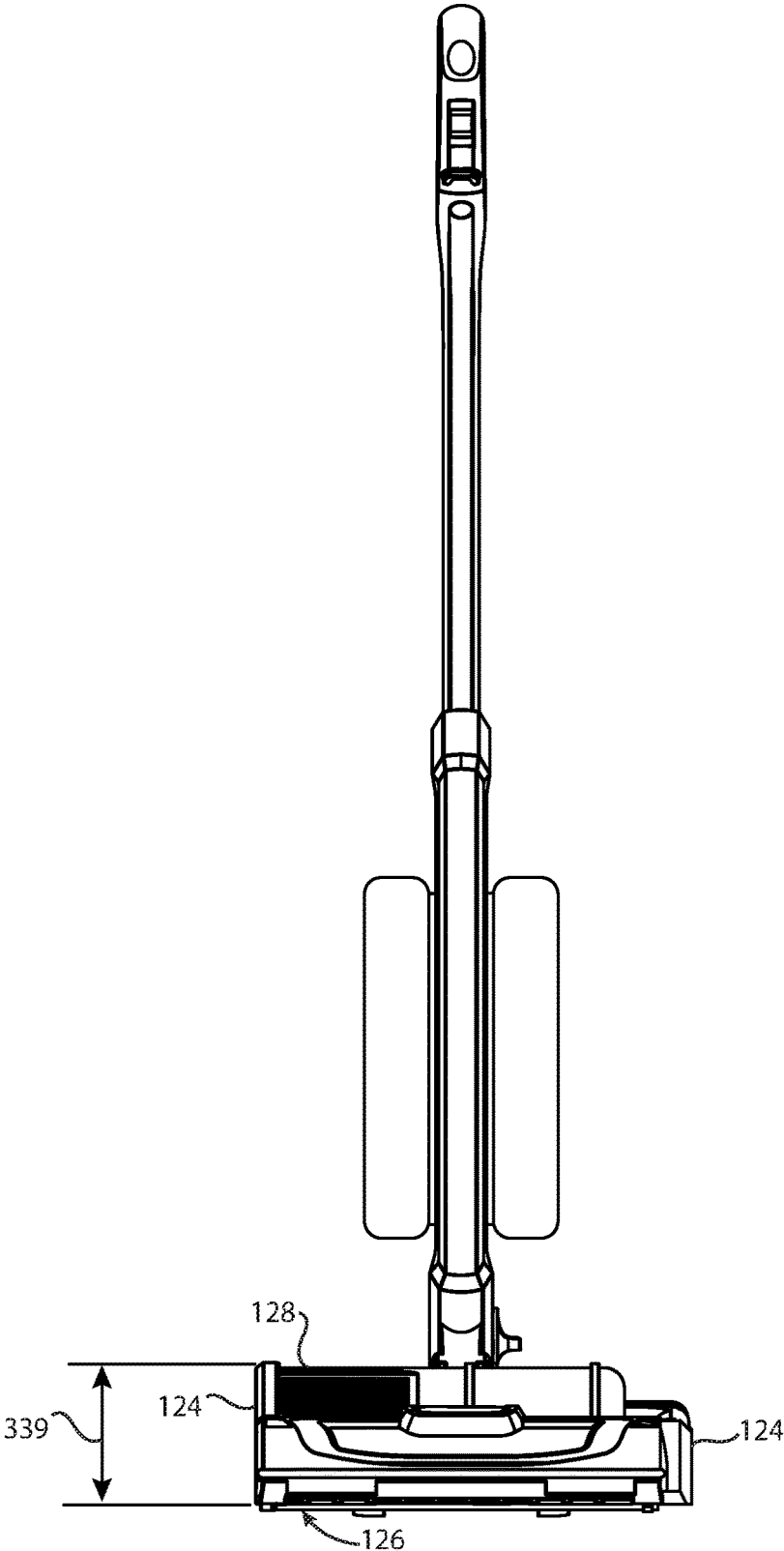

FIG. 3

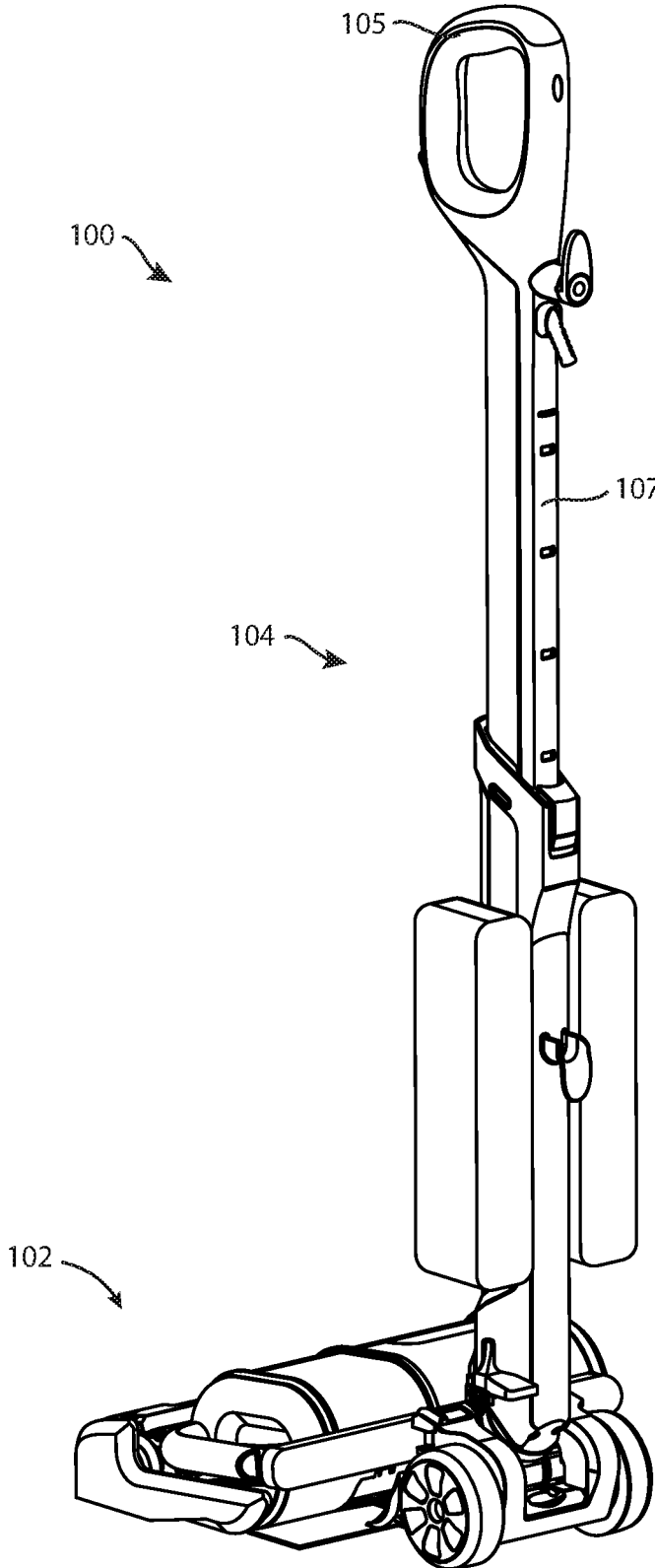

FIG. 4

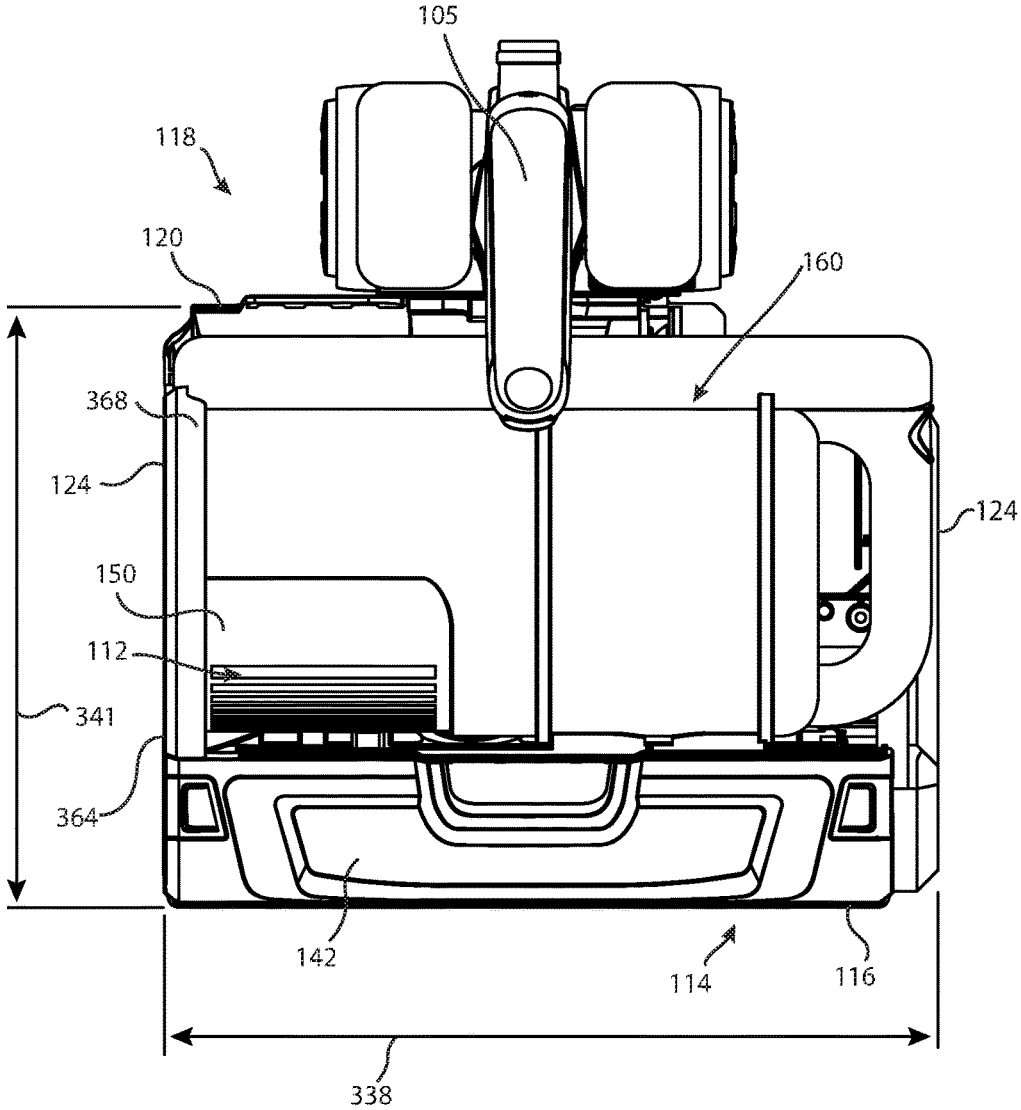

FIG. 5

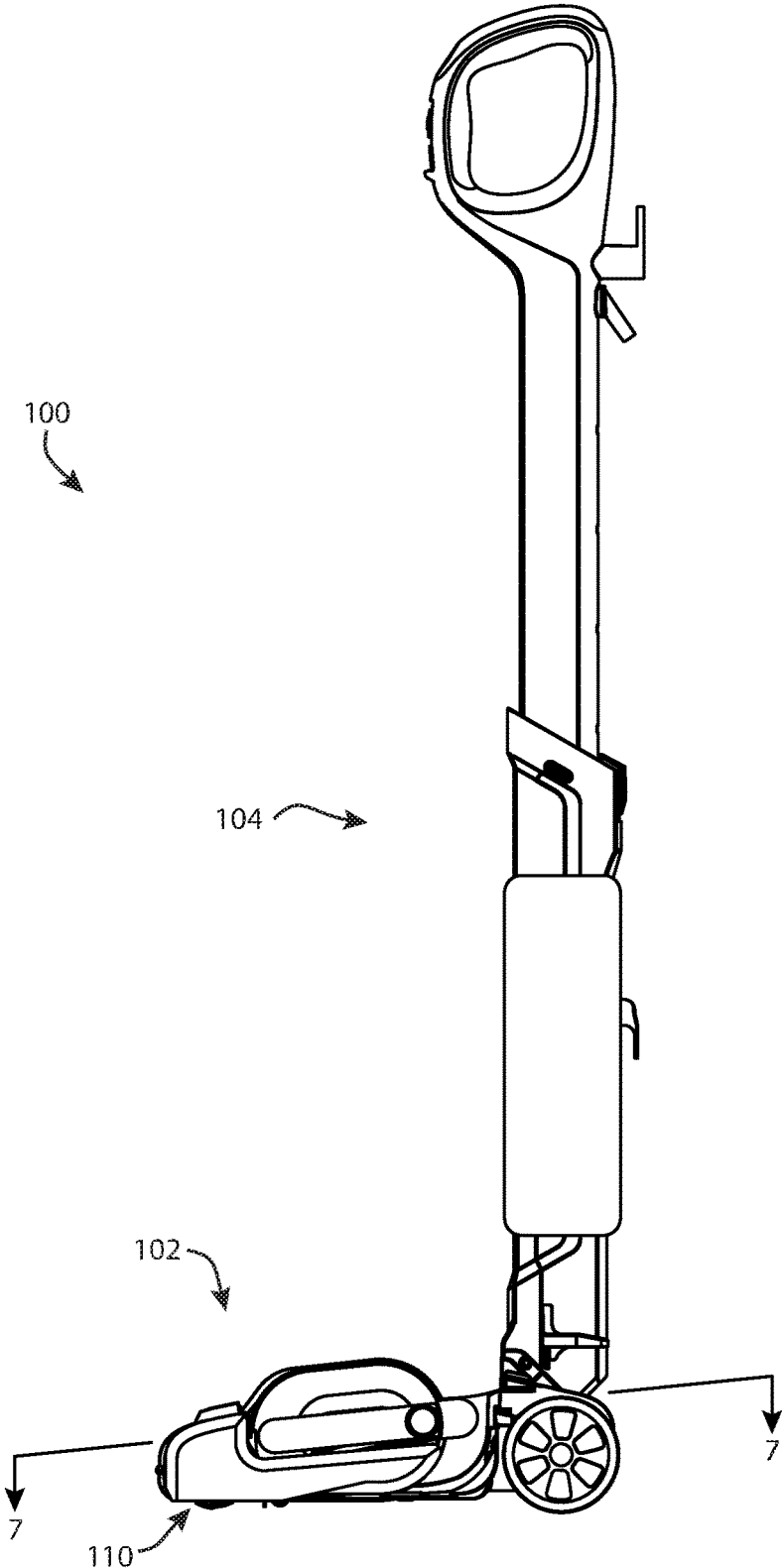

FIG.6

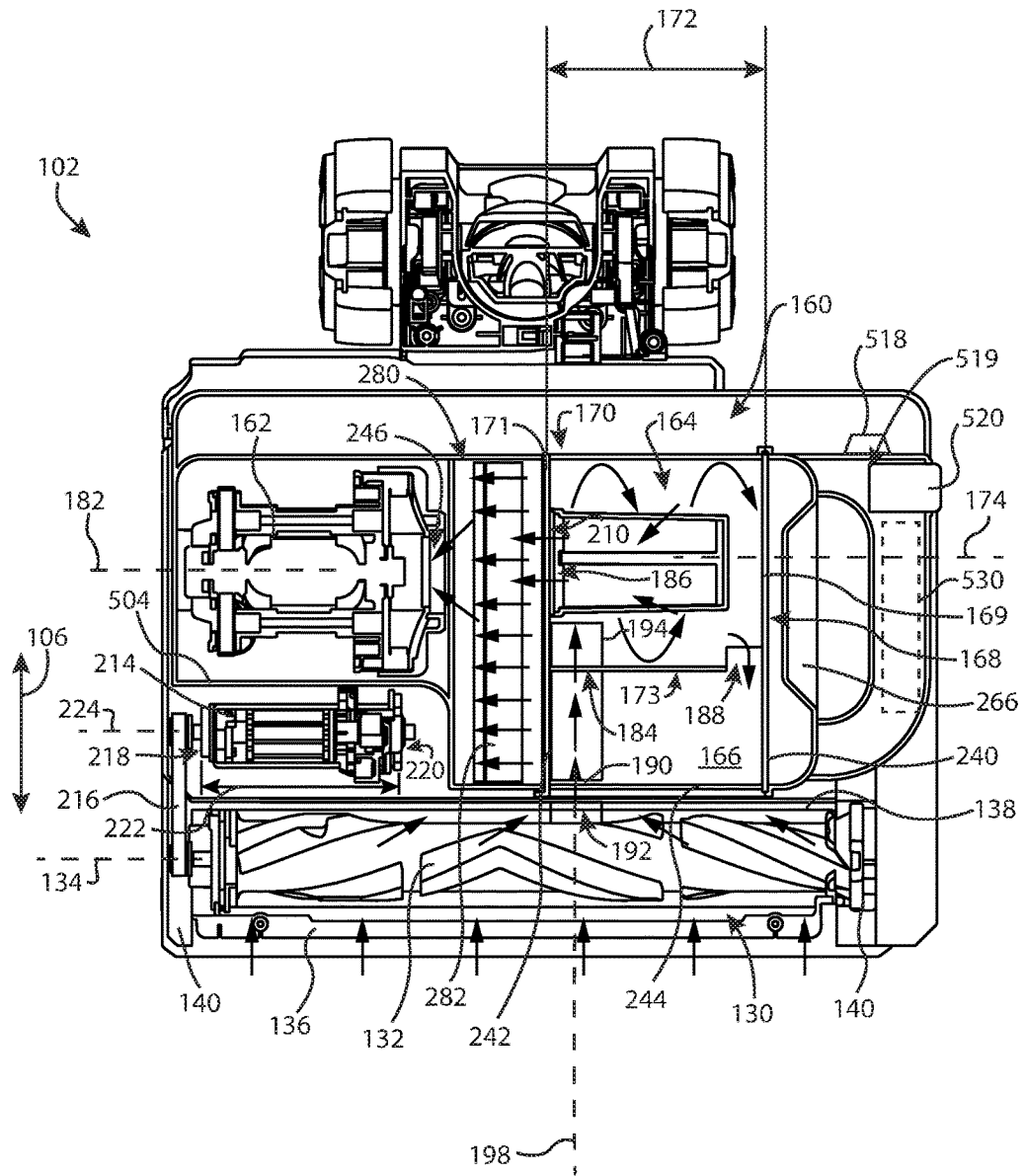

FIG 7

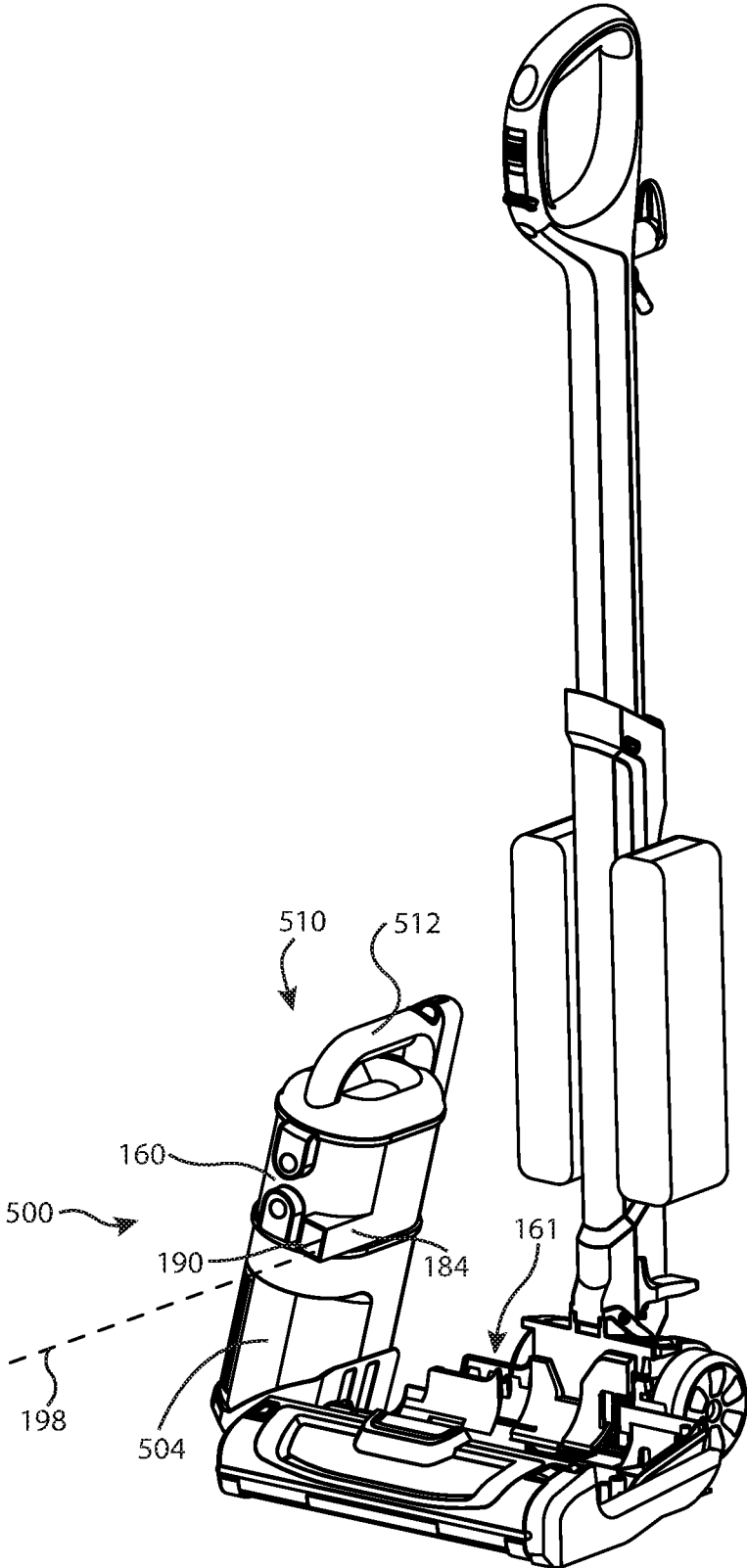

FIG. 8

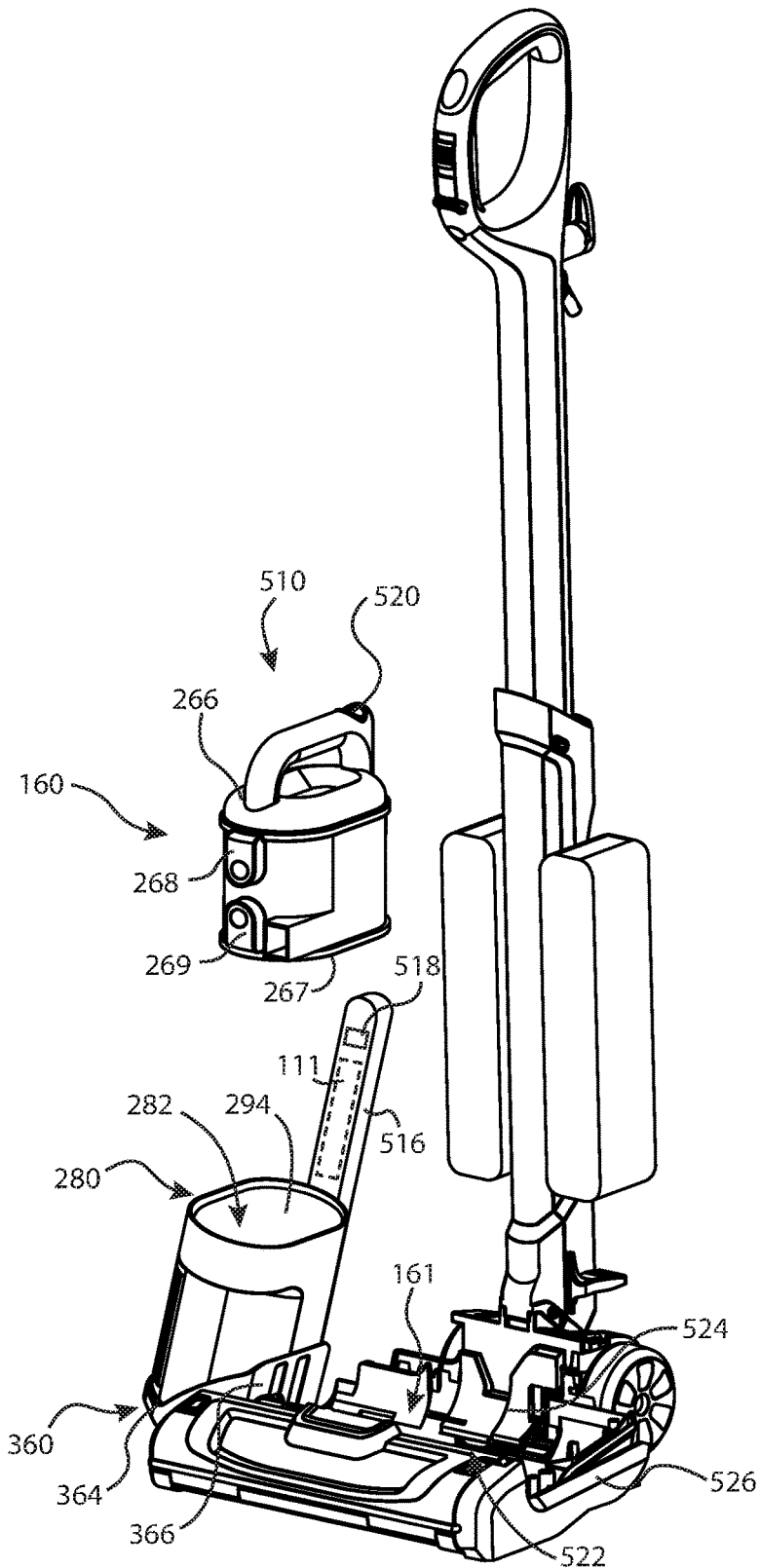

FIG. 9

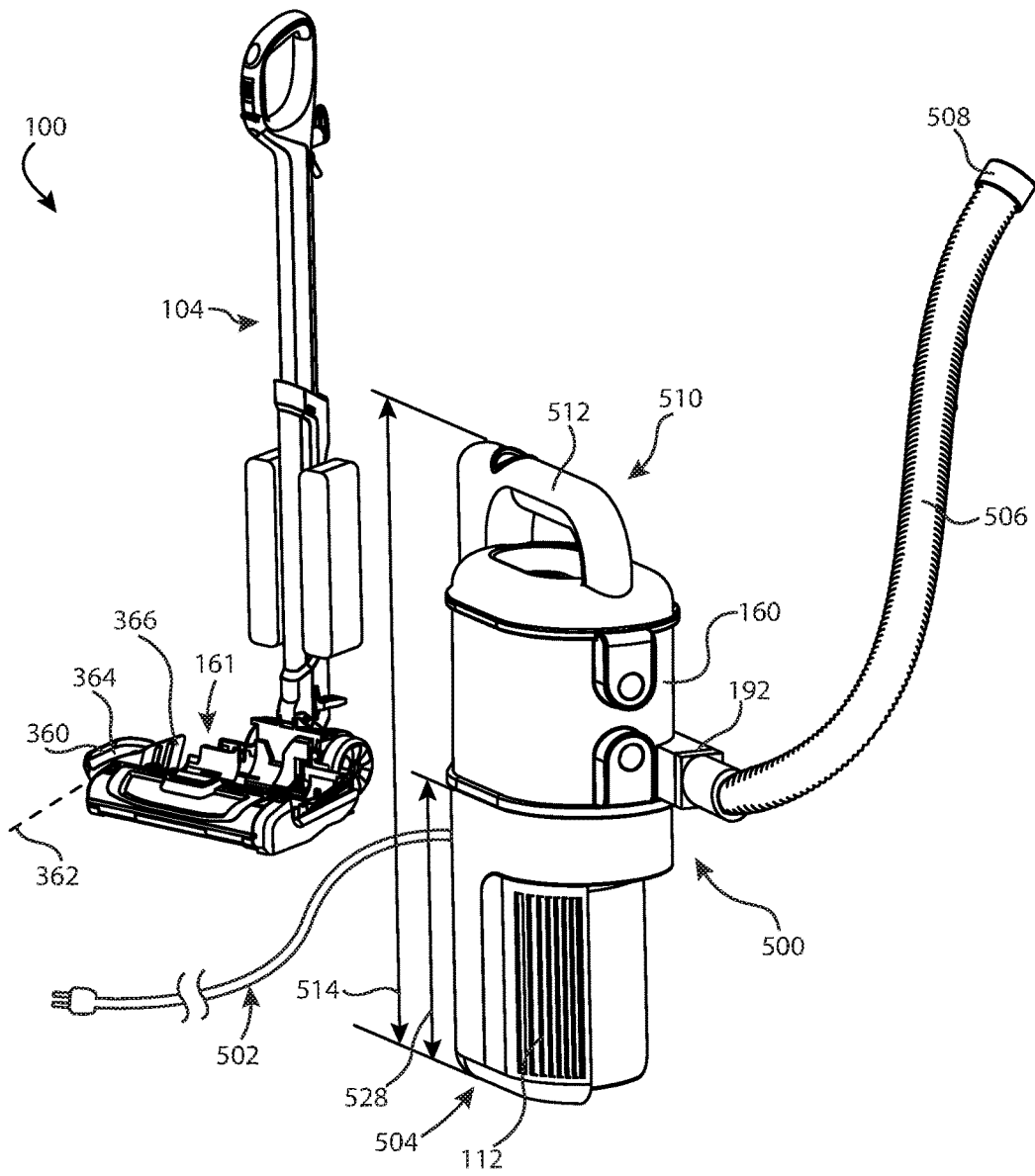

FIG. 10

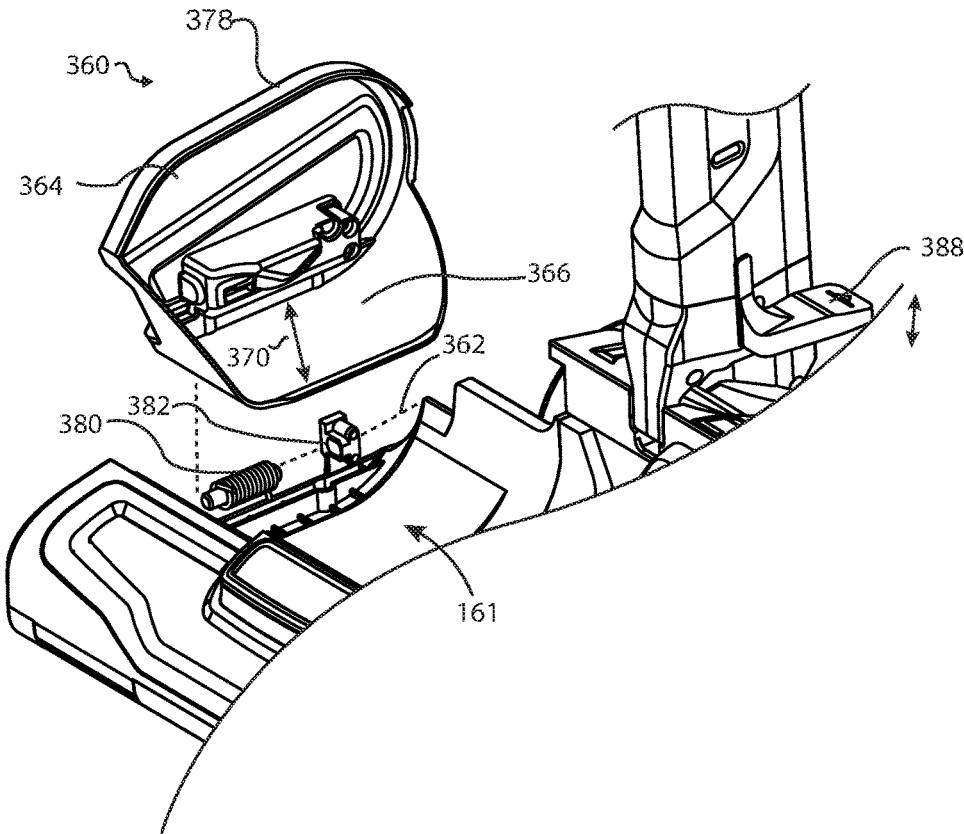

FIG. 11

**ALL IN THE HEAD SURFACE CLEANING
APPARATUS****CROSS-REFERENCE TO RELATED
APPLICATIONS**

This application is a continuation in part of co-pending U.S. patent application Ser. No. 14/829,331, which was filed on Aug. 18, 2015, which is a continuation in part of co-pending U.S. patent application Ser. No. 14/573,549, which was filed on Dec. 17, 2014, which are incorporated herein in their entirety by reference.

FIELD

This disclosure relates generally to surface cleaning apparatus, including all in the head type surface cleaning apparatus.

BACKGROUND

Various types of surface cleaning apparatus are known. These include upright surface cleaning apparatus, canister surface cleaning apparatus, stick surface cleaning apparatus and central vacuum systems. Typically, a surface cleaning apparatus has a surface cleaning head with an inlet. For example, an upright surface cleaning apparatus typically comprises an upright section containing at least an air treatment member that is pivotally mounted to a surface cleaning head. A canister surface cleaning apparatus typically comprises a canister body containing at least an air treatment member and a suction motor that is connected to a surface cleaning head by a flexible hose and a handle. Such designs are advantageous as they permit some of the operating components, and optionally all of the operating components (i.e., the suction motor and the air treatment members) to be placed at a location other than the surface cleaning head. This enables the surface cleaning head to be lighter and smaller. Reducing the weight of the surface cleaning head may increase its maneuverability. Also, reducing the height of the surface cleaning head enables the surface cleaning head to clean under furniture having a lower ground clearance.

Another type of surface cleaning apparatus is the all in the head surface cleaning apparatus. An all in the head surface cleaning apparatus has the suction motor and the air treatment members (e.g., one or more cyclones) positioned in the surface cleaning head. However, for various reasons, the all in the head vacuum cleaner has not been widely accepted by consumers.

U.S. Pat. Nos. 5,699,586; 6,012,200; 6,442,792; 7,013,528; US 2004/0134026; US 2006/0156509; and, US 2009/0056060 disclose an all in the head vacuum cleaner wherein the surface cleaning head is wedge shaped (i.e., the height of the surface cleaning head increases from the front end to the rear end). Accordingly, the height at the rear end limits the extent to which the surface cleaning head may travel under furniture. If the height is too tall, then only the front portion of the surface cleaning head may be able to be placed under furniture, thereby limiting the ability of the surface cleaning apparatus to clean under furniture.

U.S. Pat. No. 5,909,755 discloses an all in the head vacuum cleaner. However, this design has limited filtration ability. As set out in the abstract, the design uses a suction motor to draw in air having entrained particulate matter

through a filter to thereby treat the air. Accordingly, while the design is not wedge shaped, it relies upon a filter to treat the air.

SUMMARY

This summary is intended to introduce the reader to the more detailed description that follows and not to limit or define any claimed or as yet unclaimed invention. One or more inventions may reside in any combination or sub-combination of the elements or process steps disclosed in any part of this document including its claims and figures.

In accordance with one aspect of this disclosure an all in the head surface cleaning apparatus may also have an above floor cleaning mode. Accordingly, the all in the head surface cleaning apparatus may be useable in the same modes as an upright vacuum cleaner and may replace an upright vacuum cleaner. In accordance with this aspect of this disclosure, an all in the head surface cleaning apparatus may include a portable cleaning unit that is removably mounted to the surface cleaning head wherein the portable cleaning unit comprises some or all of the operating components of the all in the head surface cleaning apparatus. For example, the portable cleaning unit may comprise a suction motor and one or more air treatment members. In some embodiments, the portable cleaning unit comprises all the suction motor and all of the air treatment members. Accordingly, the suction motor and air treatment member, which are contained within the removable portable cleaning unit, are used for above floor cleaning and are connected in fluid communication with the dirty air inlet on the surface cleaning head when used in a floor cleaning mode (i.e., when the portable cleaning unit is positioned in the surface cleaning head and is therefore in its floor cleaning position). Therefore, when the portable cleaning unit is used for cleaning when separated from the surface cleaning head, the air may be subjected to the same level of filtration as when the portable cleaning unit is installed in the surface cleaning head.

One advantage of providing a removable cleaning unit may be that it allows a user to lift and carry the portable cleaning unit to a cleaning location, without having to lift the entire weight of the surface cleaning head and upper portion. Accordingly, if a user wants to clean a surface above the floor, such as furniture, curtains or the ceiling, a user may merely remove the portable cleaning unit and commence cleaning. If the portable cleaning unit includes the only suction motor of the all in the head surface cleaning apparatus, then the weight of the surface cleaning head may be reduced by providing only a single suction motor.

Another advantage is that using a common suction motor and air treatment member or members in both the floor cleaning and above floor cleaning modes may help reduce the complexity and number of components required while still providing at least two cleaning modes.

The apparatus may be configured such that the portable cleaning unit may be moved from a floor cleaning position (in which it is mounted to the surface cleaning head and fluidly connected to the dirty air inlet of the surface cleaning head and useable to clean a floor) to a removal position (in which the air flow communication between the portable cleaning unit and surface cleaning head dirty air inlet is interrupted). Preferably, the portable cleaning unit may include the handle that is revealed and/or raised when the portable cleaning unit is in or is moved to the removal position.

Preferably, the portable cleaning unit remains supported by the surface cleaning head when in the removal position,

such that it is stable and will resist falling over. One advantage of this configuration is that a handle, and other portions of the portable cleaning unit, may be raised to a position (e.g., a higher elevation) in which it is more comfortable for a user to grasp (e.g., the user may reach down a lesser distance to grasp and remove the portable cleaning unit).

The surface cleaning head may have a height which permits the entire surface cleaning head to extend under furniture. For example, the maximum height of the surface cleaning head may be less than 6 inches, less than 5 inches, or less than 4.0 inches. At the same time, the surface cleaning head may employ cyclonic air treatment technology and achieve a degree of air treatment comparable to that of leading upright cyclonic vacuum cleaners.

In accordance with one aspect, there is provided an all in the head surface cleaning apparatus comprising:

- (a) a surface cleaning head comprising:
 - (i) a rear end, a front end positioned forwardly of the rear end, an upper surface, and first and second laterally opposed sidewalls;
 - (ii) a dirty air inlet;
- (b) a portable cleaning unit removably mounted to the surface cleaning head, the portable cleaning unit comprising:
 - (i) an air treatment member assembly comprising an air treatment member;
 - (ii) a suction motor having a suction motor axis, the cleaning unit being at least partially seated within the surface cleaning head when mounted to the surface cleaning head in a floor cleaning position, the portable cleaning unit is usable for cleaning when removed from the surface cleaning head; and,
 - (iii) a clean air outlet downstream from the suction motor;
- (c) a first air flow path extending between the dirty air inlet and the clean air outlet when the portable cleaning unit is in the floor cleaning position, the first air flow path including the air treatment member and the suction motor; and,
- (d) an upper portion moveably mounted to the surface cleaning head between a storage position and a floor cleaning position, the upper portion comprising a drive handle.

In any embodiment, the surface cleaning head may have a recess and the portable cleaning unit may be positioned in the recess when the portable cleaning unit is mounted to the surface cleaning head. The recess may be provided in the upper surface of the surface cleaning head. Optionally, at least 75% of the portable cleaning unit is positioned in the recess when the portable cleaning unit is mounted to the surface cleaning head.

In any embodiment, an upper surface of the portable cleaning unit may be substantially flush with the upper surface of the surface cleaning head when the portable cleaning unit is mounted to the surface cleaning head.

In any embodiment, the portable cleaning unit may be rotatably moveable from the floor cleaning position to a removal position in which portable cleaning unit is mounted on the surface cleaning head and air flow communication between the portable cleaning unit and the dirt air inlet is interrupted.

In any embodiment, the portable cleaning unit may comprise a carry handle that may be recessed into the surface cleaning head when the portable cleaning unit is mounted to the surface cleaning head.

In any embodiment, the surface cleaning head may further comprise a moveably mounted platform and the portable cleaning unit may be removably mounted to the platform.

In any embodiment, the air treatment member assembly may comprise a cyclone assembly and the air treatment member may comprise a cyclone chamber having a longitudinal cyclone axis that extends between the first and second laterally opposed sides.

In any embodiment, the surface cleaning head may further comprise a rotating cleaning brush and a brush motor, the brush motor having a brush motor axis wherein the brush motor is positioned forward of the suction motor. Optionally, the brush motor axis and the suction motor axis may extend generally transverse to the forward direction and the brush motor may be laterally spaced from the air treatment member.

In any embodiment, the apparatus may further comprise a biasing member biasing the portable cleaning unit away from the floor cleaning position.

In accordance with another aspect, there is provided an all in the head surface cleaning apparatus comprising a surface cleaning head, the apparatus comprising:

- (a) a surface cleaning head comprising a rear end, a front end positioned forwardly of the rear end, first and second laterally opposed sidewalls and a dirty air inlet;
- (b) a portable cleaning unit removably mounted to the surface cleaning head, the portable cleaning unit comprising an air treatment member assembly and a suction motor, the cleaning unit being moveable from a floor cleaning position, in which the portable cleaning unit is in air flow communication with the dirty air inlet, to a portable cleaning unit removal position, in which the air flow communication between the portable cleaning unit and dirty air inlet is interrupted; and,
- (c) a biasing member biasing the portable cleaning unit away from the floor cleaning position; and,
- (d) an upper portion moveably mounted to the surface cleaning head between a storage position and a floor cleaning position, the upper portion comprising a drive handle.

In any embodiment, the surface cleaning head may have a recess and the portable cleaning unit may be positioned in the recess when the portable cleaning unit is mounted to the surface cleaning head and is in the floor cleaning position. Optionally, the recess may be provided in the upper surface of the surface cleaning head. At least 75% of the portable cleaning unit may be positioned in the recess when the portable cleaning unit is mounted to the surface cleaning head.

In any embodiment, an upper surface of the portable cleaning unit may be substantially flush with the upper surface of the surface cleaning head when the portable cleaning unit is mounted to the surface cleaning head.

In any embodiment, the portable cleaning unit may be rotatably moveable from the floor cleaning position to the removal position.

In any embodiment, the portable cleaning unit may comprise a carry handle that is recessed into the surface cleaning head when the portable cleaning unit is mounted to the surface cleaning head.

In any embodiment, the surface cleaning head may further comprise a moveably mounted platform and the portable cleaning unit may be removably mounted to the platform.

In any embodiment, the air treatment member assembly may comprise a cyclone assembly comprising a cyclone chamber having a longitudinal cyclone axis that extends between the first and second laterally opposed sides.

5

In any embodiment, the apparatus may further comprise a brush and a brush motor, the brush motor having a brush motor axis wherein the brush motor is positioned forward of the suction motor. Optionally, the brush motor axis and a suction motor axis may extend generally transverse to a forward direction and wherein the brush motor is laterally spaced from the air treatment member.

In any embodiment, the surface cleaning head may further comprise a brush chamber positioned toward the front end for containing a cleaning brush and the portable cleaning unit may comprise an air inlet extending along an inlet axis, wherein when the portable cleaning unit is in the floor cleaning position the inlet axis intersects the brush chamber and when the portable cleaning unit is in the removal position the inlet axis does not intersect the brush chamber.

In any embodiment, the suction motor may comprise a suction motor axis that extends generally parallel to a horizontal direction when the portable cleaning unit is in the floor cleaning position, and the suction motor axis may be inclined relative to the horizontal direction when the portable cleaning unit is in the removal position.

DRAWINGS

The drawings included herewith are for illustrating various examples of articles, methods, and apparatuses of the teaching of the present specification and are not intended to limit the scope of what is taught in any way. In the drawings:

FIG. 1 is a front perspective view of an example of an all in the head type surface cleaning apparatus;

FIG. 2 is a front perspective view of the surface cleaning apparatus of FIG. 1 with an upper portion in a use position such that the surface cleaning apparatus is in a floor cleaning mode;

FIG. 3 is a front elevation view of the surface cleaning apparatus of FIG. 1;

FIG. 4 is a rear perspective view of the surface cleaning apparatus of FIG. 1;

FIG. 5 is a top plan view of the surface cleaning apparatus of FIG. 1;

FIG. 6 is a side elevation view of the surface cleaning apparatus of FIG. 1;

FIG. 7 is a cross-sectional view of a portion of the surface cleaning apparatus, taken along line 7-7 in FIG. 6;

FIG. 8 is a front perspective view of the surface cleaning apparatus of FIG. 1 with a portable cleaning unit in a removal position;

FIG. 9 is the front perspective view of FIG. 8 with an air treatment member assembly removed;

FIG. 10 is a front perspective view of the surface cleaning apparatus of FIG. 1 with the portable cleaning unit removed from the surface cleaning head and an optional hose installed; and,

FIG. 11 is a partially-exploded perspective view of a portion of the surface cleaning apparatus of FIG. 1.

DETAILED DESCRIPTION

Various apparatuses or processes will be described below to provide an example of an embodiment of each claimed invention. No embodiment described below limits any claimed invention and any claimed invention may cover processes or apparatuses that differ from those described below. The claimed inventions are not limited to apparatuses or processes having all of the features of any one apparatus or process described below or to features common to multiple or all of the apparatuses described below. It is possible

6

that an apparatus or process described below is not an embodiment of any claimed invention. Any invention disclosed in an apparatus or process described below that is not claimed in this document may be the subject matter of another protective instrument, for example, a continuing patent application, and the applicants, inventors or owners do not intend to abandon, disclaim or dedicate to the public any such invention by its disclosure in this document.

As exemplified herein, the surface cleaning apparatus is an all in the head vacuum cleaner. It will be appreciated that, in some embodiments, aspects disclosed herein may be used in other surface cleaning apparatus such as extractors or in surface cleaning heads of other vacuum cleaners, such as an upright vacuum cleaner or a canister vacuum cleaner.

15 General Description of an all in the Head Vacuum Cleaner

Referring to FIGS. 1-6, an embodiment of a surface cleaning apparatus **100** is shown. The surface cleaning apparatus **100** includes a surface cleaning head **102** and an upper portion **104** that is movably and drivingly connected to the surface cleaning head **102**. The surface cleaning head **102** may be supported by any suitable support members, such as, for example wheels and/or rollers, to allow the surface cleaning head to be moved across the floor or other surface being cleaned. The support members (e.g., wheels) may be of any suitable configuration, and may be attached to any suitable part of the surface cleaning apparatus, including, for example, the surface cleaning head and upper portion.

The surface cleaning apparatus **100** preferably includes a dirty air inlet **110**, a clean air outlet **112** and an air flow path or passage extending therebetween. Preferably, at least one suction motor and at least one air treatment member assembly are provided in the air flow path. The air treatment member assembly may include an air treatment member, including, for example, one or more cyclones (arranged in series or in parallel with each other), filters, bags and other dirt separation devices, and a dirt collection area. Preferably, the at least one air treatment member assembly is provided upstream from the suction motor, but alternatively may be provided downstream from the suction motor or both upstream and downstream from the suction motor. In addition to the at least one air treatment member assembly, the surface cleaning apparatus may also include one or more pre-motor filters (preferably positioned in the air flow path between the air treatment member assembly and the suction motor) and/or one or more post-motor filters (positioned in the air flow path between the suction motor and the clean air outlet).

In the illustrated embodiment, the surface cleaning apparatus includes an air treatment member assembly in the form of a cyclone bin assembly **160** (FIGS. 5, 7 and 9) positioned in the air flow path downstream from the dirty air inlet **110**, and a suction motor **162** positioned downstream from the cyclone bin assembly **160**. Preferably, the cyclone bin assembly **160** is detachable from surface cleaning head **102** with or without the suction motor **162** (FIG. 9) for emptying. The suction motor **162** has an air inlet **246** and can rotate about a suction motor axis **182**.

Upper portion **104** may be of any design known in the art that is drivingly connected to surface cleaning head **102** so as to permit a user to move surface cleaning head **102** across a surface to be cleaned (such as a floor). Upper portion **104** may be moveably (e.g., pivotally) connected to surface cleaning head for movement between an upright storage position as exemplified in FIG. 1 and an inclined in use position as exemplified in FIG. 2. If upper portion **104** is moveably connected to surface cleaning head **102** about

only one axis or rotation (e.g., a horizontal axis), then upper portion **104** may be used to move surface cleaning head **102** in a generally forward/backward direction of travel, indicated by arrow **106**. A direction generally orthogonal to the direction of travel, indicated by arrow **108** defines a lateral or transverse direction. In some embodiments, upper portion **104** may be rotatably connected to surface cleaning head **102**, such as by a swivel connection, so as to enable a user to steer the surface cleaning head **102** using the upper portion **104**.

Upper portion **104** may comprise a hand grip portion **105** and a drive handle or drive shaft **107**. Drive shaft **107** may be useable as an above floor cleaning wand and/or it may provide electrical cord storage and/or auxiliary cleaning tool storage and/or it may be used to hang the surface cleaning apparatus on a wall when not in use.

In the embodiment illustrated, the surface cleaning apparatus **100** is an all in the head type vacuum cleaner in which the functional or operational components for the transport and treatment of fluid (e.g., air) entering the dirty air inlet of the vacuum cleaner (e.g. the suction motor, air treatment member, filters, motors, etc.) are all contained within the surface cleaning head **102** portion of surface cleaning apparatus **100**. Providing the functional air flow components within the surface cleaning head may help reduce the size and/or weight of the upper portion and/or help lower the centre of gravity of the surface cleaning apparatus. Accordingly, the hand weight experienced by a user operating surface cleaning apparatus **100** may be reduced.

In some embodiments, the surface cleaning head may also be configured to accommodate functional components that do not form part of the air flow path, such as, for example, brush motors, brushes, on board energy storage systems, controllers and other components.

Alternatively, while being free from air flow components, the upper section may include some non-airflow related components, such as, for example, electrical cord connections, electrical cord storage members, handles, actuators, steering components, and other functional, on board energy storage systems. In the illustrated example, the upper portion **104** includes an optional storage compartment **109** (for example for storing auxiliary cleaning tools) and an optional battery pack **111** that may be mounted to, and movable with, the drive shaft **107**. The battery pack **111** may be electrically connected to the suction motor, brush motor, lights and/or any other electrical components on the apparatus. If the surface cleaning apparatus is battery powered, the batteries may be located elsewhere.

Referring to FIGS. 3-5, in the illustrated example, the surface cleaning head **102** includes a front end **114** having a front face **116**, a rear end **118** spaced rearwardly from the front end and having a rear face **120**, and a pair of side faces **124** that are laterally spaced apart from each other and extend from the front face **116** to the rear face **120**. The surface cleaning head **102** also has a bottom face **126** that extends between the front end **114**, rear end **118**, and side faces **124**. The bottom face **126** is positioned to face the surface being cleaned when the surface cleaning apparatus **100** is in use.

Referring to FIG. 3, a top face **128** is generally spaced apart from and overlies bottom face **126**. Together, front face **116**, rear face **120**, side faces **124**, bottom face **126**, and top face **128** co-operate to bound an interior of the surface cleaning head **102**, which, in the illustrated example, is configured to house the functional components of the air flow path of the surface cleaning apparatus **100**. Preferably, in an all in the head type vacuum cleaner, the surface

cleaning head **102** includes the dirty air inlet **110** and the clean air outlet **112**. The surface cleaning apparatus **100** has an overall depth **341** (FIG. 5), measured in the forward/backward direction, which may be any suitable depth sufficient to accommodate the components of the surface cleaning apparatus **100**, and may be less than about 20 inches, less than about 15 inches, less than about 10 inches, less than about 9 inches, less than about 8.5 inches, and optionally less than about 8 inches.

In the exemplified embodiment, surface cleaning head **102** has a generally rectangular footprint when viewed from above. It will be appreciated that front, rear, and sides faces need not extend linearly and that surface cleaning head may be of various shapes.

As exemplified in FIG. 7, surface cleaning head **102** may include a brush chamber **130** that is configured to house a rotatable agitator brush **132**. Rotatable brush **132** may be rotatable about a brush axis **134** that may be generally orthogonal to the direction of travel **106** of surface cleaning head **102**. Alternatively, any other agitation or cleaning member known in the art may be used in place of, or in addition to, rotatable brush **132**. Further, rotatable brush **132** may be any rotatable brush known in the art and may be driven by any drive means known in the art, such as a fan belt, direct drive, providing the brush motor internal of rotatable brush **132**, an air driven turbine, or the like. In the illustrated embodiment, the surface cleaning head **102** also includes a brush motor **214** that is drivingly connected to the rotatable brush **132** by a drive linkage **216**, which in the illustrated example includes a drive belt. The brush motor **214** has a first end **218** and a second end **220** that are spaced apart from each other by a brush motor length **222**, along a brush motor axis **224**, about which the rotor of the brush motor **214** rotates.

As exemplified in the cross-sectional view of FIG. 7, brush chamber **130** may include a front wall **136**, a rear wall **138**, two sidewalls **140** and a top wall **142** (FIG. 5). Brush chamber **130** may be located at the front **114** of surface cleaning head **102**, and, as in the illustrated embodiment, an outer surface of front wall **136** of brush chamber **130** may form at least a portion of front face **116** of surface cleaning head **102**.

As exemplified, the bottom side of brush chamber **130** is at least partially open and forms the dirty air inlet **110** of surface cleaning apparatus **100**. In the illustrated example the open bottom side of the brush chamber **130** is generally rectangular in shape, but alternatively could be configured in other shapes. As exemplified, the brush chamber **130** may extend from the bottom face **126** to the top face **128** of the surface cleaning head **102**, so that an outer surface of the top wall **142** of the brush chamber **130** forms part of the top face **128** of the surface cleaning head **102**, and the open, bottom side of the brush chamber **130** forms part of the bottom face **126** of the surface cleaning head **102**.

As exemplified in FIG. 5, the clean air outlet **112** may be provided on the upward facing, top face **128** of the surface cleaning head **102** and may be covered by a grill **150**. Preferably, the grill **150** is removable to allow access to the clean air outlet **112**. An advantage of this design is that treated air is directed away from the surface to be cleaned and away from a user (who is standing behind upper portion **104**). Alternately clean air outlet **112** may direct treated air rearwardly.

Optionally a post-motor filter may be provided upstream of the suction motor, such as at the clear air outlet **112**, to filter air that has passed through the air treatment member and suction motor. The filter may be provided as a generally

planar post-motor filter made from foam and/or felt that is positioned beneath the grill **150**. Removing the grill **150** provides access to the post-motor filter for inspection and/or replacement. Optionally, instead of, or in addition to the felt filter, the post-motor filter may include one or more other filters or filtering media, including, for example, a HEPA filter, an electrostatic filter, a cyclonic post-motor filter or other suitable filter.

It will be appreciated that the forgoing is a general description of an all in the head vacuum cleaner. It will be appreciated that the actual size and shape of the surface cleaning head may depend upon which of the following aspects are included in the product design.

Cyclone Bin Assembly

The following is a description of a cyclone bin assembly having various features, any or all of which may be used (individually or in any combination or sub-combination) in any surface cleaning apparatus or in any combination or sub-combination with any other feature or features disclosed herein.

Referring to FIGS. 7-9, in the illustrated example, cyclone bin assembly **160** includes a cyclone chamber **164** and a dirt collection chamber **166**. In the illustrated example, dirt collection chamber **166** is external the cyclone chamber **164**. In accordance with one feature of the cyclone bin assembly, dirt collection chamber **166** may be positioned forward and/or rearward of cyclone chamber **164** and not on top of or below cyclone chamber **164**. An advantage of this design is that by not positioning the dirt collection chamber above or below the cyclone chamber (or by reducing the height of the portion of the dirt collection chamber above or below the cyclone chamber) the height **339** (FIG. 3) of the surface cleaning head **102** may be reduced without reducing the diameter of cyclone chamber **164** and/or the diameter of the cyclone chamber may be increased (thereby increasing the air flow rate through the vacuum cleaner) without increasing the height of the surface cleaning head.

As exemplified, cyclone chamber **164** has a first cyclone end **168** with a first end wall **169**, and a second cyclone end **170** with a second end wall **171**. A generally cylindrical cyclone sidewall **173** extends between first end wall **169** and second end wall **171**, spaced apart from each other by cyclone length **172** along a cyclone axis **174**, about which air circulates. The cyclone chamber **164** also includes a cyclone air inlet **184**, a cyclone air outlet **186**, and a dirt outlet **188**.

As exemplified in FIGS. 7 and 8, the cyclone air inlet **184** may include an upstream or inlet end **190** that is connectable to a brush chamber air outlet **192** that may be provided in the rear wall **138** of the brush chamber **130**. Cyclone air inlet **184** may also include a downstream end **194** that includes an opening formed in the cyclone sidewall **173**, and a connecting portion extending through dirt collection chamber **166** between upstream end **190** and downstream end **194**. The air flow connection between brush chamber outlet **192** and cyclone chamber **164** may form a first air flow path portion, which is a portion of the overall air flow path connecting dirty air inlet **110** to clean air outlet **112**. As exemplified the first flow path may be generally free from bends/corners and is essentially linear along its entire length (with the exception of minor variations in the wall diameter), from opening **192** in brush chamber rear wall **138** to a tangentially oriented opening in cyclone sidewall **173** proximate downstream end **194**. Providing a linear first air flow path may help reduce air flow losses as air flows through the first flow path. In addition, the first flow path is relatively short and provides a generally direct air flow path from brush chamber **130** to cyclone chamber **164**. Providing a relatively short, direct air

flow path may help reduce the likelihood of the air flow path becoming clogged by debris or otherwise blocked.

Cyclone air inlet **184** may be provided at any desired location on cyclone chamber **164**, and in the illustrated example is provided toward a bottom side of cyclone chamber **164**, below a horizontal plane containing cyclone axis **174**. In this configuration, a cyclone air inlet axis **198** (FIG. 8) intersects cyclone chamber **164**, brush chamber **130**, and rotating brush **132** when the cyclone bin assembly **160** is in the floor cleaning position (FIG. 1).

In the illustrated example, inlet end **190** of cyclone air inlet **184** is integrally formed with cyclone bin assembly **160**. In this configuration, inlet end **190** can be disconnected from air outlet **192** of brush chamber **130** and removed from the surface cleaning head with cyclone bin assembly **160**.

As exemplified in FIG. 7, in the illustrated example, cyclone air outlet **186** includes an aperture **210** that is generally centrally located on second end wall **171** of cyclone chamber **164**. Any cyclone air outlet may be used.

The dirt collection chamber may be of any suitable configuration. Preferably, as exemplified in FIG. 7, dirt collection chamber **166** is exterior to cyclone chamber **164**, and preferably includes a first end wall **240**, a second end wall **242**, and a sidewall **244** extending therebetween. As exemplified, sidewall **244** partially laterally surrounds cyclone chamber **164**. At least partially positioning dirt collection chamber **166** forward or rearward of cyclone chamber **164** may help reduce the overall height of the surface cleaning head **102**. As exemplified, cyclone sidewall **173** may be coincident with sidewall **244** at one or more locations around its perimeter. Optionally, portions of dirt chamber sidewall **244** can form portions of the outer or exposed surface of surface cleaning apparatus **100** when cyclone bin assembly **160** is mounted in cavity **161**.

As exemplified, a majority of dirt collection chamber **166** is located forward of cyclone chamber **164** (in the direction of travel **106** of the surface cleaning head **102**), between cyclone chamber **164** and brush chamber **130**. In some configurations, the rear portions of cyclone sidewall **173** and dirt collection chamber sidewall **244** may be coincident, and the front portion of the cyclone sidewall **173** may be spaced apart from the front portion of the dirt collection chamber sidewall **244**. Locating the cyclone chamber **164** toward the rear of cyclone bin assembly **160** may help align cyclone air outlet **186** with air inlet **246** (FIG. 7) of suction motor **162**. Locating the dirt collection chamber **166** forward of cyclone chamber **164** may help make dirt collection chamber **166** more easily viewable by a user (particularly if some or all of dirt collection chamber sidewall **244** is transparent and there is no lid overlying the cyclone bin assembly **160** or such a lid is transparent), which may allow a user to inspect the condition of dirt collection chamber **166** without having to remove cyclone bin assembly **160** from cavity **161**.

In the illustrated example, dirt collection chamber **166** is located solely in front of cyclone chamber **164** and does not extend above or below the cyclone chamber **164**. It will be appreciated that small portions of the dirt collection chamber may be positioned above or below the cyclone chamber without significantly deviating from the advantage of this feature. In this configuration, the overall height of cyclone bin assembly **160** (measured in a vertical direction when the cyclone bin assembly is mounted to the surface cleaning head) is generally equal to the outer diameter of cyclone chamber **164** (i.e. including the wall thicknesses), while the overall width of cyclone bin assembly **160** (measured in the front/back direction **106** when the cyclone bin assembly is mounted to the surface cleaning head) is greater than the

11

cyclone diameter. Providing the dirt collection chamber **166** only in front of cyclone chamber **164** may help reduce the overall height of cyclone bin assembly **160** while still providing a dirt collection chamber **166** with a practical internal storage volume. Reducing the overall height of cyclone bin assembly **160** may help reduce the overall height **339** (FIG. 3) of surface cleaning head **102** when cyclone bin assembly **160** is mounted in cavity **161**. Preferably, the overall height **339** of surface cleaning head **102** is less than about 10 inches, less than about 8 inches, less than about 6 inches, less than about 5 inches, less than about 4.5 inches and optionally less than 4 inches.

Alternatively, the cyclone bin assembly **160** may be configured so that the dirt collection chamber is located entirely behind the cyclone chamber (i.e. between the cyclone chamber and the rear face of the surface cleaning head), or is located partially in front of and partially behind the cyclone chamber and so that the dirt collection chamber extends partially or entirely above and/or below the cyclone chamber.

Cyclone chamber **164** may be in communication with a dirt collection chamber **166** by any suitable cyclone dirt outlet known in the art. Preferably the cyclone chamber includes at least one dirt outlet in communication with the dirt chamber that is external the cyclone chamber.

Optionally, to help facilitate emptying the dirt collection chamber, at least one of or both of the end walls may be openable. Similarly, one or both of the cyclone chamber end walls and may be openable to allow a user to empty debris from the cyclone chamber.

Referring to FIG. 7, in the illustrated example, the end wall **240** of the dirt collection chamber is openable to empty dirt collection chamber **166**. The first cyclone end wall **169** is mounted to, and openable with, dirt chamber end wall **240** and together both form part of openable door **266** of cyclone bin assembly **160**. Door **266** is moveable between a closed position and an open position. When door **266** is open, both cyclone chamber **164** and dirt collection chamber **166** can be emptied concurrently. Alternatively, the end walls of the dirt collection chamber and the cyclone chamber need not be connected with each other, and the dirt collection chamber may be openable independently of the cyclone chamber.

Preferably, openable door **266** can be secured in its closed position until opened by a user. Door **266** may be held closed using any suitable latch or fastening mechanism, such as latch **268** (FIG. 9). Optionally, the latch can be provided in a location that is inaccessible when the cyclone bin assembly is mounted to the surface cleaning head. This may help prevent the door from being opened inadvertently. In the illustrated example, when cyclone bin assembly **160** is mounted in cavity **161**, latch **268** is disposed between dirt chamber sidewall **244** and brush chamber **130** and is inaccessible to the user.

Optionally, the opposing ends of the cyclone chamber **164** and dirt collection chamber **166** may also be openable. For example, the end walls **171** and **242** may both be provided as portions of a second openable door **267** (FIG. 9) that is held in its closed position using a latch **269**. In this arrangement, both the ends of the cyclone and dirt collection chambers can be simultaneously opened. This may help facilitate emptying and/or cleaning of the cyclone bin assembly **160**.

In the illustrated example, portions of cyclone sidewall **173** coincide with portions of dirt chamber sidewall **244** and form portions of the outer, exposed surface of cyclone bin assembly **160**. Further, when cyclone bin assembly **160** is attached to surface cleaning head **102**, portions of the outer

12

surface of cyclone bin assembly **160** provide portions of, and are substantially flush with the top face **128** of surface cleaning head **102**.

The cyclone bin assembly **160** may be detachable from the rest of the apparatus as a generally sealed unit, but for the inlet end **190** and the outlet aperture **210**. Providing a detachable cyclone bin assembly **160** allows a user to carry cyclone bin assembly **160** to a garbage can for emptying, without needing to carry or move the rest of surface cleaning apparatus **100**. The cyclone bin assembly may be removable from when the portable cleaning unit **500** has been removed from the surface cleaning head and/or when the suction motor is still connected to the surface cleaning head.

It will be appreciated that some of the embodiments disclosed herein may not use any of the features of the cyclone bin assembly disclosed herein and that, in those embodiments, any air treatment member assembly known in the art may be used.

Removable Portable Cleaning Unit

The following is a description of a portable cleaning unit having various features, any or all of which may be used (individually or in any combination or sub-combination) in any surface cleaning apparatus or in any combination or sub-combination with any other feature or features disclosed herein.

Optionally, a portion of the apparatus **100** can be detachable from the rest of the apparatus **100**, and can be operable as a portable cleaning unit. For example, portions of the apparatus **100** may be separable from the surface cleaning head **102** and upper portion **104** and usable as a separate cleaning unit. This may allow a user to clean without having to move around the weight of the cleaning head **102** and upper portion **104**. This may also allow a user to operate the apparatus **100** in an above floor cleaning configuration, where the removable cleaning unit may be used to clean above-floor areas, such as furniture and window coverings.

Optionally, the removable portions of the apparatus **100** may include the same suction motor and cyclone bin assembly that are utilized in the floor cleaning configuration. This may allow a common suction motor and cyclone bin assembly to be used in at least two cleaning configurations, and may help reduce the need to provide additional suction motors and air treatment members.

Referring to FIG. 10, in the illustrated embodiment, the apparatus **100** includes a removable, portable cleaning unit **500** that includes the cyclone bin assembly **160** and a housing portion **504** that houses the suction motor **162**, and in this example includes the clean air outlet **112**. When the portable cleaning unit **500** is mounted to the surface cleaning head **102** (FIG. 1), the apparatus **100** is in its floor cleaning configuration. When the portable cleaning unit **500** is removed (FIG. 10) the apparatus is in an above floor cleaning configuration.

Optionally, one or more auxiliary cleaning tools, wands, hoses and the like may be selectively connected to the portable cleaning unit **500**, preferably when in the above floor cleaning configuration. FIG. 10 illustrates one example of a flexible hose **506** that may be connected to the upstream end **190** of cyclone air inlet **184**. In this configuration, the upstream, inlet end **508** of hose **506** may provide a second, auxiliary dirty air inlet that is fluidly connected to the cyclone bin assembly **160** and suction motor **162**. When not in use, the hose **506** may be detached and stored separately, or optionally collapsed and stored in the storage compartment **109**.

As exemplified in FIG. 7, the portable cleaning unit may also include a pre-motor filter chamber **280** that houses a

pre-motor filter **282**. An advantage of this design is that the pre-motor filter chamber is removable with the portable cleaning unit **500**. The pre-motor filter may be provided at any location. As exemplified, the pre-motor filter **282** and the pre-motor filter chamber **280** may be positioned between the cyclone chamber air outlet **186** and the suction motor air inlet **246**. In such an embodiment, the air exiting the cyclone chamber **164** may travel in a generally linear direction to the suction motor **162** while still passing through the pre-motor filter. In accordance with a further feature, the pre-motor filter chamber may comprise the air flow path between the cyclone chamber and the suction motor. Accordingly, no additional air flow conduit may be required or, alternately, the length of any such additional air flow conduit may be reduced.

For example, as exemplified in FIG. 7, the pre-motor filter chamber **280** may be positioned adjacent the air outlet **186** of the cyclone chamber **164**, such that when the cyclone bin assembly **160** is mounted on the surface cleaning head **102**, the pre-motor filter chamber **280** is positioned, preferably transversely, between the cyclone chamber **164** and the suction motor **162**.

Optionally, as exemplified, the pre-motor filter chamber **280** is opened when the cyclone bin assembly **160** is separated from the housing portion **504**. For example, as shown in FIG. 9, separating the cyclone bin assembly **160** unseals one end of the pre-motor filter chamber **280** and reveals the pre-motor filter **282** positioned therein. As exemplified, the upstream face **294** of the pre-motor filter **282** (through which air enters the pre-motor filter) is exposed when the cyclone bin assembly **160** is removed. Accordingly, when a user removes the cyclone bin assembly **160** to empty the dirt collection chamber, the user may also check the condition of the pre-motor filter (e.g., by looking at the pre-motor filter if part or all of the pre-motor filter chamber is transparent) or by opening the pre-motor filter chamber and inspecting the pre-motor filter. Preferably, the pre-motor filter **282** remains in place when the cyclone bin assembly **160** is removed, as shown in FIG. 9. Alternately, the pre-motor filter **282** may be removed with the cyclone bin assembly **160**.

The cyclone bin assembly **160** and/or a pre-motor filter housing may be releasably attached to the housing **504** or other portion of the portable cleaning unit **500** using any suitable mechanism, including releasable latches, locks, clips and the like. As exemplified in FIG. 9, the portable cleaning unit **500** may include a support structure **516** extending from the housing portion **504**. The cyclone bin assembly **160** includes a locking mechanism having a first latch portion **519** (FIG. 7) that may engage a corresponding notch **518** on the support structure **516**. When the cyclone bin assembly **160** is attached, the lower door **267** seats on and seals the upper end of the housing portion **504**, and the upper door **266** is locked to the support structure **516**. To release the cyclone bin assembly **160**, a user may depress an unlocking actuator in the form of a button **520** provided on the handle **510**. Depressing the button **250** may disengage the latch portion from the notch **518**, thereby releasing the cyclone bin assembly **160**.

Alternatively, instead of providing a support structure, the cyclone bin assembly **160** may be locked directly to the housing portion **504**.

Portable Cleaning Unit Mounting Portion

The following is a description of a mounting portion of the surface cleaning apparatus that may be used to removably receive and support the portable cleaning unit. The mounting portion may have various features, any or all of

which may be used (individually or in any combination or sub-combination) in any surface cleaning apparatus or in any combination or sub-combination with any other feature or features disclosed herein.

To accommodate the portable cleaning unit **500**, the surface cleaning head **102** may be provided with any suitable mounting portion. Preferably, the mounting portion is configured to at least partially receive the portable cleaning unit **500**, and optionally may receive all or substantially all of the cleaning unit. This may help reduce the overall size of the cleaning head **102** while the portable cleaning unit **500** is attached.

Referring to FIGS. 8 and 9, in the illustrated example, surface cleaning head **102** includes a mounting portion in the form of a cavity **161** for removably receiving portable cleaning unit **500**. The cavity **161** is sized to receive at least a portion of portable cleaning unit **500** and, in the example illustrated, has a generally open top. This allows portions of the portable cleaning unit **500** to remain visible when portable cleaning unit **500** is mounted in cavity **161**. This can also allow a user to access the portable cleaning unit **500** without having to open or remove a separate cover panel or lid. The absence of a cover panel may help reduce the overall weight of surface cleaning apparatus **100**, and may simplify the portable cleaning unit **500** removal process.

As exemplified, the cavity **161** is a generally open-topped, U-shaped recess that is provided in the upper surface **128** of the surface cleaning head **102**. The cavity **161** may be configured to allow the portable cleaning unit **500** to be inserted and removed from the cavity **161** in a generally upwardly/downwardly motion, whether by lifting the portable cleaning unit **500** vertically or by pivoting the portable cleaning unit **500**, such as on a cradle **360** as described herein.

As exemplified, the cavity **161** includes a front wall **522** and an opposing rear wall **524** (FIG. 9). The cradle **360** may be located at one side of the cavity **161** and a sidewall **526** may be provided at the opposing side. Together, the walls of the cavity **161** may partially surround the portable cleaning unit **500** and help keep it in place when in the floor cleaning position. Optionally, the cavity **161** may be sized such that at least 25% of the portable cleaning unit **500** is contained within the cavity **161** when in the floor cleaning position. In some configurations, at least 50%, at least 60%, at least 70%, at least 75%, at least 80%, at least 85%, at least 90% and/or at least 95% of the portable cleaning unit **500** may be positioned within the cavity **161** when in the floor cleaning position. Increasing the amount of the portable cleaning unit **500** that is positioned within the cavity **161** may help retain the portable cleaning unit **500** within the cavity **161** when the apparatus **100** is in use. Optionally, the entire (i.e. 100%) of the portable cleaning unit **500** may be positioned within the cavity **161** in some embodiments.

When the portable cleaning unit **500** is mounted to the surface cleaning head **102** in a floor cleaning position, the portable cleaning unit **500** preferably does not extend beyond upper surface **128** and/or side faces **124** of the surface cleaning head **102**. This can help reduce the overall size of the surface cleaning head **102** in the floor cleaning position.

Optionally, portable cleaning unit **500** may be configured to partially surround and/or nest with other portions of the surface cleaning head **102** when in the floor cleaning position. This may help reduce the overall size of the surface cleaning head **102**. For example, in the present embodiment the portable cleaning unit **500** partially nests with the brush motor **214**, and its respective housing, as shown in FIG. 7.

In this configuration, the brush motor **214** is positioned forward of the suction motor **162**, and is laterally offset (to the left as illustrated) from the pre-motor filter chamber **280** and the cyclone bin assembly **160**. In this configuration, the cyclone bin assembly **160** may have a larger depth in the forward/rearward direction than if it were positioned rearward of the brush motor **214**.

Portable Cleaning Unit Removal Position

The following is a description of an optional feature of the teachings disclosed herein, in which the portable cleaning unit may be moved from a floor cleaning position to a removal position, in which the portable cleaning unit is no longer in air flow communication with the surface cleaning head but remains physically supported by the surface cleaning head. The removal position may be any suitable position and may have various features, any or all of which may be used (individually or in any combination or sub-combination) in any surface cleaning apparatus or in any combination or sub-combination with any other feature or features disclosed herein. Alternatively, a surface cleaning apparatus may be configured having some of the advantages and features described herein (such as a removable portable cleaning unit) but need not be configured to provide a removal position. Instead, the portable cleaning unit may be moved directly from the floor cleaning position to an above floor cleaning position without being temporarily held in a removal position (e.g., the portable cleaning unit may be merely lifted out of the surface cleaning head by a user).

As mentioned herein, preferably the portable cleaning unit **500** is removable from the cavity **161** on the surface cleaning head **102**. Preferably, to help facilitate removal of the cyclone bin assembly **160**, the cyclone bin assembly **160** may be movable from a use or floor cleaning position (for example FIGS. 1-7) to a removal position (for example FIGS. 8 and 9). In the floor cleaning position, the portable cleaning unit **500** may provide the air flow connection between the dirty air inlet **110** and the suction motor **162**, and ultimately the clean air outlet **112**. In the removal position, the portable cleaning unit **500** is positioned so that air flow communication between the dirty air inlet **110** and the suction motor **162** is interrupted. In this configuration, the cyclone bin assembly **160** is positioned to enable a user to remove the cyclone bin assembly **160** from the surface cleaning head for emptying and optionally to remove the entire portable cleaning unit **500** for above floor cleaning.

For example, when the portable cleaning unit **500** is in the floor cleaning position, the upstream end **190** of the cyclone air inlet **184** may be in air flow communication with the air outlet **192** of the brush chamber **130**. In this configuration, the surface cleaning apparatus **100** is useable to clean the floor. In contrast, when the portable cleaning unit **500** is moved to the removal position, air flow communication between the cyclone bin assembly **160** and the brush chamber **130** is interrupted.

Preferably, when in the removal position, the portable cleaning unit **500** may continue to be at least partially, and preferably entirely, supported by the surface cleaning head **102**. This may allow a user to move the portable cleaning unit **500** into the removal position without having to lift or remove the portable cleaning unit **500** or support its weight.

In accordance with one feature, the portable cleaning unit **500** may be moved relative to the surface cleaning apparatus when transitioning from the floor cleaning position to the removal position. For example, the portable cleaning unit **500** may translate, pivot, rotate or otherwise move relative to other portions of the surface cleaning apparatus (such as the surface cleaning head **102**) when transitioning from the floor cleaning position to the removal position. Moving the

portable cleaning unit **500** and/or changing its orientation when transitioning from the floor cleaning position to the removal position may help position the portable cleaning unit **500** and/or cyclone bin assembly **160** in a position that is relatively easier to access for a user. For example, when the portable cleaning unit **500** is in the floor cleaning position it may be substantially or fully nested within the cavity **161** on the surface cleaning head **102** and may be disposed relatively close to the ground. It may be inconvenient or uncomfortable for a user to reach all the way down to the surface cleaning head **102** to grasp the portable cleaning unit **500**.

In accordance with another feature, the surface cleaning apparatus **100** may be configured so that when the portable cleaning unit **500** is transitioned to the removal position it is arranged in a position that is more convenient for a user to reach it, including, for example, by moving some or all portions of the portable cleaning unit **500** to higher elevations and/or by exposing features (such as handles) that are exposed for access by a user in the removal position and are less exposed, or inaccessible, when in the floor cleaning position.

In accordance with another feature, the portable cleaning unit **500** may be biased toward or into one or both of the floor cleaning position and the removal position. Preferably, the portable cleaning unit **500** is at least biased toward the removal position. Accordingly, when a lock that secures the portable cleaning unit **500** in the use position is released, the portable cleaning unit **500** may be moved sufficiently out of the cavity **161** to assist a user to pick up and remove the portable cleaning unit **500** from the surface cleaning head.

To help facilitate access and removal of the portable cleaning unit **500**, in the illustrated example the portable cleaning unit **500** can be rotated, relative to the surface cleaning head **102**, into the removal position (FIG. 8). To help support the portable cleaning unit **500** and facilitate its movement, the surface cleaning apparatus **100** may include a moveable support or platform member that at least partially supports, and may fully support, the portable cleaning unit **500** in the removal position. Preferably, the portable cleaning unit **500** may be mounted to and supported by (e.g., locked to) the moveable platform member, such that movement of the moveable platform results in a corresponding movement of the cyclone bin assembly.

As exemplified in FIGS. 8-10, the surface cleaning head may include a movably mounted platform in the form of the cradle **360** that is configured to removably receive and support the laterally outer end of the portable cleaning unit **500**, and is rotatable relative to the surface cleaning head about a cradle axis **362** (FIG. 10). In the illustrated example, the cradle axis **362** is parallel to the forward direction **106** of travel of the surface cleaning apparatus **100**, and is generally orthogonal to the cyclone axis **174**, suction motor axis **182** and brush motor axis **224** (FIG. 7).

As exemplified in FIG. 11, the cradle **360** may be generally L-shaped and includes an end wall **364** and a sidewall **366** extending from the end wall **364** (see also FIG. 5) by a length **370**. The length **370** is preferably selected to be less than the length **528** of the housing portion **504** of the portable cleaning unit **500**. In this configuration, the cyclone bin assembly **160** is spaced apart from the sidewall **366**, which may help facilitate removal of the cyclone bin assembly **160** while the housing portion **504** is seated in the cradle **360**.

The end wall **364** may be configured to receive the laterally outer end of the portable cleaning unit **500** in a relatively snug engagement. As exemplified, the end wall **364** may

include an upstanding rim **368** (FIG. 5) that surrounds the housing portion **504** of the portable cleaning unit and helps retain the portable cleaning unit **500** on the cradle **360** when in the removal position.

When the portable cleaning unit **500** is in the floor cleaning position, the cradle **360** is rotated so that the end wall **364** is generally horizontal and is disposed vertically between the housing portion **504** and a bottom surface of the cavity **161**. In this configuration the end wall **364** of the cradle **360** is generally vertical. When the portable cleaning unit **500** is in the floor cleaning position, an upper portion **378** (FIG. 11) of the rim **368** helps inhibit vertical movement of the portable cleaning unit **500** relative to the cradle **360**, and the rest of the surface cleaning head **102**.

In the illustrated example, rotation of the cradle **360** about its axis **362** causes a corresponding rotation of the portable cleaning unit **500** from the generally horizontal floor cleaning position to a generally upright removal position. Referring to FIG. 10, from the removal position, the portable cleaning unit **500** may be lifted upwardly out of the cradle **360** for above floor cleaning use.

Optionally, the cradle may be freely moveable between the cleaning and removal positions, or alternatively it may be biased. For example, in the illustrated example, a torsion spring **380** (FIG. 11) and an optional dampener assembly may be connected to the cradle **360** to bias the cradle **360** toward the removal position. The torsion spring resistance may be selected so that it is sufficient to pivot the cradle **360** and portable cleaning unit **500**, including the weight of the debris within the dirt collection chamber **166**, to the upright removal position. The damper assembly may be provided to help slow the rotation of the cradle **360** as the portable cleaning unit **500** approaches the removal position. An example of a suitable mechanism and related structure is the mechanism, including torsion springs and damper assemblies, used in association with the cradle and movable cyclone bin assembly disclosed in U.S. application Ser. No. 14/573,549 (Conrad), the entirety of which is incorporated herein by reference.

As exemplified in, the cradle **360** may be only biased toward the removal position. To return the portable cleaning unit **500** to the floor cleaning position a user may reseat the laterally outer end of the portable cleaning unit **500** onto the end wall **364** of the cradle **360**, and then pivot the portable cleaning unit **500** into the cavity **161**.

In accordance with another feature, the portable cleaning unit **500** may be securable in one or both of the cleaning and removal positions using a lock. The lock may be any suitable apparatus, and optionally may be configured to lock the portable cleaning unit **500** in the floor cleaning position until the lock is released. Preferably, the lock may be automatically re-engaged when the portable cleaning unit **500** is moved into the floor cleaning position so that the portable cleaning unit **500** will be held in place without requiring a user to manually re-latch or reengage the lock. The lock may be configured to engage one or both of the cradle and the portable cleaning unit **500**, or any other suitable component of the surface cleaning apparatus.

For example, a latch on the surface cleaning head **102** may be configured to engage a corresponding latch member provided on the outer surface of the portable cleaning unit **500**. When the portable cleaning unit **500** is placed in the cavity **161**, the latch portions may interlock with each other, thereby securing the portable cleaning unit **500**. To release the portable cleaning unit **500**, an actuator, such as the foot pedal **388** (FIG. 1 or 11) may be depressed by a user. The foot pedal **388** may be linked to the latch member on the

surface cleaning head **102**, such that depressing the foot pedal **388** disengages the latch members from each other thereby releasing the portable cleaning unit **500**. One example of a suitable locking mechanism and related structure is the locking mechanism used in association with the cradle and movable cyclone bin assembly disclosed in U.S. application Ser. No. 14/573,549 (Conrad), the entirety of which is incorporated herein by reference.

Portable Cleaning Unit Carry Handle

The following is a description of an optional feature of the teachings disclosed herein, in which the portable cleaning unit includes a carry handle. The carry handle may be of any suitable configuration and may have various features, any or all of which may be used (individually or in any combination or sub-combination) in any surface cleaning apparatus or in any combination or sub-combination with any other feature or features disclosed herein. In some embodiments, the carry handle may be at least partially nested within the surface cleaning head, or otherwise inaccessible, when the portable cleaning unit is in the floor cleaning position, and may be moved to a second position where the carry handle is more exposed for grasping by a user when the portable cleaning unit is not in the floor cleaning position.

Optionally, the portable cleaning unit **500** may include a carry handle that can be used to maneuver the portable cleaning unit **500** when it is detached from the surface cleaning head **102**. The carry handle may be provided on any suitable portion of the portable cleaning unit **500**, including, for example, on the cyclone bin assembly **160**, and may be of any configuration. Providing the carry handle on the cyclone bin assembly **160** may allow the carry handle to be used to maneuver the entire portable cleaning unit **500** when the cyclone bin assembly **160** is connected to the housing **504**, and to maneuver only the cyclone bin assembly **160** when it is separated from the housing **504**. As exemplified in FIGS. 8-10, the portable cleaning unit **500** may include a carry handle **510** that is provided on, and is movable with, the openable door **266** at the end of the cyclone bin assembly **160**. The carry handle **510** may include hand grip portion **512** that is graspable by a user.

In accordance with one feature, the portable cleaning unit carry handle, such as handle **510**, may be recessed within the surface cleaning head **102** when the portable cleaning unit is in the floor cleaning position (FIG. 1) and may be exposed and/or made more readily available when the portable cleaning unit **500** is in a removal position (FIGS. 8-10). The handle portion **510** may help increase the overall height of the portable cleaning unit **500** in the removal position, and preferably may form an uppermost portion of the portable cleaning unit **500** while it is in the removal position. Providing a handle **510** at a relatively high, and optionally uppermost position on the portable cleaning unit **500** may help position the handle **510** at an elevation that is relatively comfortable, or is more comfortable, for a user to reach (e.g. to help minimize the amount of bending required by the user).

Optionally, the portable cleaning unit **500** may be configured so that the portable cleaning unit **500**, including the handle **510**, extends across most or all of the entire width **338** (FIG. 5) of the surface cleaning head **102**. That is, a length **514** of the portable cleaning unit **500** (FIG. 10) may be selected so that it is equal to or less than the width **338** of the surface cleaning head **102**. Optionally, the length of the portable cleaning unit **500**, including the handle portion **510** may be between about 60% and about 100% of the width **338** of the surface cleaning head **102**, and preferably can be between about 70% and about 100% and more

preferably can be between about 80% and about 100% of the width 338. In the illustrated example, the length 514 of the portable cleaning unit 500 is generally equal to the width 338 of the surface cleaning head 102. Configuring the portable cleaning unit 500 to extend the width 338 of the surface cleaning apparatus may help increase the size of, e.g., the dirt collection region of the portable cleaning unit 500, while remaining within the width 338 of the surface cleaning head 102 when in the floor cleaning position.

In accordance with another feature, the handle 510 may be configured to be positioned at an upper portion of the cyclone bin assembly when the cyclone bin assembly is in the removal position and (as exemplified in FIG. 28) may extend upwardly when the cyclone bin assembly is in the removal position.

It will be appreciated that some of the embodiments disclosed herein may not use all or any of the features of the dirt collection chamber disclosed herein and that, in those embodiments, any dirt collection chamber known in the art may be used.

Electrical Cord

The following is a description of an electrical cord that may be used by itself in any surface cleaning apparatus or in any combination or sub-combination with any other feature or features disclosed herein.

In accordance with one aspect, power may be supplied to the surface cleaning apparatus using the electrical cord. In the illustrated examples, AC power is supplied to the surface cleaning apparatus using an electrical cord that may be connected to a wall socket. The cord may be connected to the apparatus at any suitable location, including, for example on the surface cleaning head itself, or on the upper portion 104. If connected to the upper section, the cord attachment point may be toward an upper end of the upper section (e.g., generally adjacent the hand grip portion 105), and one or more electrical conductors may extend from the cord attachment point to the surface cleaning head. The electrical conductors may be external and/or internal the upper section. Optionally, the electrical conductors may be adjustable, and preferably may be extensible and/or resilient (e.g. a coiled electrical cord) so that the electrical conductors may accommodate changes in length of the upper portion (e.g., if the upper portion is a telescoping handle) without requiring decoupling or reconfiguration, and without interrupting electrical supply to the surface cleaning head.

In accordance with one feature, the electrical cord may be connected to an upper portion of the drive handle 107, such as the upper end of the upper section, e.g., on or adjacent and slightly beneath the hand grip 105. Connecting the electrical cord on an upper portion of the drive handle, such as adjacent the hand grip may help reduce the likelihood that the cord will interfere with the movement of the surface cleaning head. This positioning may also help make it convenient for a user to hold a portion of the cord with his/her free hand (i.e. the hand that is not holding the hand grip 105) and to manipulate the cord to help prevent entanglement or other impediments to the vacuuming process. Spacing the electrical cord attachment point away from the surface cleaning head may also help reduce the need to move the electrical cord when the surface cleaning head is in close proximity to and/or is beneath furniture or other objects. This may help reduce the chances of the electrical cord becoming tangled or snagged while the surface cleaning apparatus is in use.

In accordance with another feature, the electrical cord may be detachably connected to the surface cleaning apparatus. This may allow the cord to be detached for storage, or

for an alternative or replacement cord to be connected to the apparatus. This may also allow the cord to be detached when not needed, such as if the surface cleaning apparatus is being powered by an alternative power source.

Alternatively, as in the example illustrated in FIG. 1, an electrical cord 502 may be directly connected to the portable cleaning unit 500. The cord 502 may be used to power the portable cleaning unit 500 when in the floor cleaning configuration (FIG. 1) and it may be detachable from the rest of the apparatus 100 with the portable cleaning unit 500 so as to also be used when in the above floor cleaning configuration (FIG. 10).

Optionally, a power cord 502 may be detachably connected to the upper portion of drive shaft 107, shown using dashed lines in FIG. 1, to power the apparatus 100 when in the floor cleaning mode. The same or an alternate power cord may be detachably connected to the portable cleaning unit 500 to power the portable cleaning unit 500 when in the above floor cleaning mode. Such a power cord 502 may be the same cord 502 that was connected to the portable cleaning unit 500 (i.e. it can be detached from the portable cleaning unit 500 and attached to the upper portion 104, and vice versa). Alternatively, a second cord 502 can be provided, and the cord 502 connected to the portable cleaning unit 500 may be reeled in, stowed, removed and the like when the apparatus 100 is operated in the floor cleaning configuration. In some embodiments, the cord connected to the portable cleaning unit 500 may be the only cord required, and a cord need not be connected to the upper portion 104 in the floor cleaning configuration.

It will be appreciated that some of the embodiments disclosed herein may not use any of the features of the electrical cord disclosed herein and that, in those embodiments, the electrical cord may be of various constructions or a detachable electrical cord may not be used.

Cordless Mode

The following is a description of a cordless operating mode that may be used by itself in any surface cleaning apparatus or in any combination or sub-combination with any other feature or features disclosed herein.

Optionally, the surface cleaning apparatus may include one or more portable energy storage devices, such as one or more batteries. The onboard battery may be a DC power source. Providing an onboard portable energy storage device may allow the surface cleaning apparatus to be operated in a cordless mode, in which the surface cleaning apparatus may be powered by the onboard energy storage device and need not be plugged into a wall socket.

Optionally, when operated on DC battery power, as opposed to external AC power, the rotating brush motor and/or the suction motor may operate at a reduced rate or may be otherwise configured to reduce power consumption (e.g., the motor may have dual windings to be operable on both AC and DC power). If required, a converter module may be provided to convert the external power supply (e.g. AC) into a format (e.g., DC) that is compatible with the motor, configured to re-charge the batteries, or is otherwise preferred over the native incoming format.

The battery may be any suitable type of battery, including a rechargeable battery. Optionally, when the surface cleaning apparatus is electrically connected to an AC power source (e.g., a wall socket), power from the AC source may be used to re-charge the battery, to directly power/drive the suction motor and/or rotating brush motor, or to simultaneously run the suction motor and/or brush motor and re-charge the battery. In this configuration, when the surface cleaning apparatus is operated while coupled to an AC

power source, the battery in the cleaning head may be charged and the suction motor and brush motor may be driven by AC power and/or a combination of AC and battery power. Then, when the surface cleaning apparatus is electrically decoupled from the AC power source, the surface cleaning apparatus can be operated on battery power alone.

Alternatively, or in addition to positioning a battery in the surface cleaning head, one or more batteries may be provided within the upper portion and electrically connected to the suction motor and/or other components in the surface cleaning head. Providing at least some batteries in the upper portion may provide extra space to accommodate the batteries, as compared to the space limitations within the surface cleaning head. Positioning batteries in the upper portion may also alter the weight distribution of the surface cleaning apparatus, which may alter the “feel” of the apparatus in a user’s hand. In embodiments where the electrical cord is connected to the upper portion, providing batteries within the upper portion may help facilitate the use of a convenient electrical connection between the incoming power from the electrical cord and the batteries and/or charging equipment. This may help reduce the need to run multiple electrical conductors between the upper portion and the surface cleaning head.

It will be appreciated that some of the embodiments disclosed herein may not use any of the features of the cordless mode disclosed herein and that, in those embodiments, the cordless mode may be of other designs or a cordless mode may not be used.

As exemplified, the apparatus **100** may include a battery pack **111** on the upper portion **104** that may provide power when in the floor cleaning configuration. Alternately or in addition, a secondary battery pack **111** may optionally be provided in the portable cleaning unit **500**, such as within the support structure **516** (see FIG. 9) and or in the handle **510** (see FIG. 7), to power the suction motor **162** when the portable cleaning unit **500** is installed in and separated from, or only when installed in, the surface cleaning head **102**. The battery pack **530** is shown schematically using dashed lines as one example of a possible placement (within the handle **510**) and may be electrically connected to the suction motor **162** using any suitable internal wiring.

In one embodiment, an on board power source may be provided as part of portable cleaning unit **500** and the power cord **502** may be provided at any location on surface cleaning apparatus **100**, such as upper portion **104**. In the floor cleaning configuration, the surface cleaning apparatus may be operated on power provided by the power cord **502**. In the above floor cleaning configuration, the portable cleaning unit may be powered by the on board power source (e.g., the batteries). The on board power source may be recharged when the portable cleaning unit is mounted to the surface cleaning head. Optionally, the power cord **502** may be used to operate the portable cleaning unit **500** when in the above floor cleaning configuration. For example, if the power cord **502** is detachable, the portable cleaning unit may be operated without the power cord attached when in the above floor cleaning configuration. If the on board power source are exhausted when the user still desires to perform above floor cleaning, the power cord **502** may be attached to the portable cleaning unit **500** and the user may continue to perform above floor cleaning.

What has been described above has been intended to be illustrative of the invention and non-limiting and it will be understood by persons skilled in the art that other variants and modifications may be made without departing from the scope of the invention as defined in the claims appended

hereto. The scope of the claims should not be limited by the preferred embodiments and examples, but should be given the broadest interpretation consistent with the description as a whole.

The invention claimed is:

1. An all in the head surface cleaning apparatus comprising:

(a) a surface cleaning head comprising:

(i) a rear end, a front end positioned forwardly of the rear end, an upper surface, and first and second laterally opposed sidewalls;

(ii) a dirty air inlet;

(b) a portable cleaning unit removably mounted to the surface cleaning head, the portable cleaning unit comprising:

(i) an air treatment member assembly comprising an air treatment member;

(ii) a suction motor having a suction motor axis, the cleaning unit being at least partially seated within the surface cleaning head when mounted to the surface cleaning head in a floor cleaning position, the portable cleaning unit being usable for cleaning when removed from the surface cleaning head; and,

(iii) a clean air outlet downstream from the suction motor;

(c) a first air flow path extending between the dirty air inlet and the clean air outlet when the portable cleaning unit is in the floor cleaning position, the first air flow path including the air treatment member and the suction motor; and,

(d) an upper portion moveably mounted to the surface cleaning head between a storage position and a floor cleaning position, the upper portion comprising a drive handle

wherein at least 75% of the portable cleaning unit is positioned in the recess when the portable cleaning unit is mounted to the surface cleaning head.

2. The apparatus of claim 1 wherein the surface cleaning head has a recess and the portable cleaning unit is positioned in the recess when the portable cleaning unit is mounted to the surface cleaning head.

3. The apparatus of claim 2 wherein the recess is provided in the upper surface of the surface cleaning head.

4. The apparatus of claim 1 wherein an upper surface of the portable cleaning unit is substantially flush with the upper surface of the surface cleaning head when the portable cleaning unit is mounted to the surface cleaning head.

5. An all in the head surface cleaning apparatus comprising:

(a) a surface cleaning head comprising:

(i) a rear end, a front end positioned forwardly of the rear end, an upper surface, and first and second laterally opposed sidewalls;

(ii) a dirty air inlet;

(b) a portable cleaning unit removably mounted to the surface cleaning head, the portable cleaning unit comprising:

(i) an air treatment member assembly comprising an air treatment member;

(ii) a suction motor having a suction motor axis, the cleaning unit being at least partially seated within the surface cleaning head when mounted to the surface cleaning head in a floor cleaning position, the portable cleaning unit being usable for cleaning when removed from the surface cleaning head; and,

(iii) a clean air outlet downstream from the suction motor;

23

- (c) a first air flow path extending between the dirty air inlet and the clean air outlet when the portable cleaning unit is in the floor cleaning position, the first air flow path including the air treatment member and the suction motor; and
- (d) an upper portion moveably mounted to the surface cleaning head between a storage position and a floor cleaning position, the upper portion comprising a drive handle

wherein the portable cleaning unit is rotatably moveable from the floor cleaning position to a removal position in which portable cleaning unit is mounted on the surface cleaning head and air flow communication between the portable cleaning unit and the dirt air inlet is interrupted.

6. The apparatus of claim 1 wherein the portable cleaning unit comprises a carry handle that is recessed into the surface cleaning head when the portable cleaning unit is mounted to the surface cleaning head.

7. The apparatus of claim 1 wherein the surface cleaning head further comprises a moveably mounted platform and the portable cleaning unit is removably mounted to the platform.

8. An all in the head surface cleaning apparatus of claim 1 comprising:

- (a) a surface cleaning head comprising:
 - (i) a rear end, a front end positioned forwardly of the rear end, an upper surface, and first and second laterally opposed sidewalls;
 - (ii) a dirty air inlet;
- (b) a portable cleaning unit removably mounted to the surface cleaning head, the portable cleaning unit comprising:
 - (i) an air treatment member assembly comprising an air treatment member;
 - (ii) a suction motor having a suction motor axis, the cleaning unit being at least partially seated within the surface cleaning head when mounted to the surface cleaning head in a floor cleaning position, the portable cleaning unit being usable for cleaning when removed from the surface cleaning head; and,
 - (iii) a clean air outlet downstream from the suction motor;
- (c) a first air flow path extending between the dirty air inlet and the clean air outlet when the portable cleaning unit is in the floor cleaning position, the first air flow path including the air treatment member and the suction motor; and
- (d) an upper portion moveably mounted to the surface cleaning head between a storage position and a floor cleaning position, the upper portion comprising a drive handle

wherein the air treatment member assembly comprises a cyclone assembly and the air treatment member comprises a cyclone chamber having a longitudinal cyclone axis that extends between the first and second laterally opposed sides.

9. The apparatus of claim 1 wherein the surface cleaning head further comprises a rotating cleaning brush and a brush motor, the brush motor having a brush motor axis wherein the brush motor is positioned forward of the suction motor.

10. The apparatus of claim 9 wherein the brush motor axis and the suction motor axis extend generally transverse to the forward direction and wherein the brush motor is laterally spaced from the air treatment member.

24

11. The apparatus of claim 1 further comprising a biasing member biasing the portable cleaning unit away from the floor cleaning position.

12. An all in the head surface cleaning apparatus comprising a surface cleaning head, the apparatus comprising:

- (a) a surface cleaning head comprising a rear end, a front end positioned forwardly of the rear end, first and second laterally opposed sidewalls and a dirty air inlet;
- (b) a portable cleaning unit removably mounted to the surface cleaning head, the portable cleaning unit comprising an air treatment member assembly and a suction motor, the cleaning unit being moveable from a floor cleaning position, in which the portable cleaning unit is in air flow communication with the dirty air inlet, to a portable cleaning unit removal position, in which the air flow communication between the portable cleaning unit and dirty air inlet is interrupted;
- (c) a biasing member biasing the portable cleaning unit away from the floor cleaning position; and,
- (d) an upper portion moveably mounted to the surface cleaning head between a storage position and a floor cleaning position, the upper portion comprising a drive handle.

13. The apparatus of claim 12 wherein the surface cleaning head has a recess and the portable cleaning unit is positioned in the recess when the portable cleaning unit is mounted to the surface cleaning head and is in the floor cleaning position.

14. The apparatus of claim 13 wherein the recess is provided in the upper surface of the surface cleaning head.

15. The apparatus of claim 13 wherein at least 75% of the portable cleaning unit is positioned in the recess when the portable cleaning unit is mounted to the surface cleaning head.

16. The apparatus of claim 12 wherein an upper surface of the portable cleaning unit is substantially flush with the upper surface of the surface cleaning head when the portable cleaning unit is mounted to the surface cleaning head.

17. The apparatus of claim 12 wherein the portable cleaning unit is rotatably moveable from the floor cleaning position to the removal position.

18. The apparatus of claim 12 wherein the portable cleaning unit comprises a carry handle that is recessed into the surface cleaning head when the portable cleaning unit is mounted to the surface cleaning head.

19. The apparatus of claim 12 wherein the surface cleaning head further comprises a moveably mounted platform and the portable cleaning unit is removably mounted to the platform.

20. The apparatus of claim 12 wherein the air treatment member assembly comprises a cyclone assembly comprising a cyclone chamber having a longitudinal cyclone axis that extends between the first and second laterally opposed sides.

21. The apparatus of claim 12 further comprising a brush and a brush motor, the brush motor having a brush motor axis wherein the brush motor is positioned forward of the suction motor.

22. The apparatus of claim 21 wherein the brush motor axis and a suction motor axis extend generally transverse to a forward direction and wherein the brush motor is laterally spaced from the air treatment member.

23. The apparatus of claim 12, wherein the surface cleaning head further comprises a brush chamber positioned toward the front end for containing a cleaning brush and wherein the portable cleaning unit comprises an air inlet extending along an inlet axis, wherein when the portable

cleaning unit is in the floor cleaning position the inlet axis intersects the brush chamber and when the portable cleaning unit is in the removal position the inlet axis does not intersect the brush chamber.

24. The apparatus of claim 12, wherein the suction motor 5 comprises a suction motor axis that extends generally parallel to a horizontal direction when the portable cleaning unit is in the floor cleaning position, and wherein the suction motor axis is inclined relative to the horizontal direction when the portable cleaning unit is in the removal position. 10

* * * * *