



US010271698B2

(12) **United States Patent**  
**Conrad**

(10) **Patent No.:** **US 10,271,698 B2**

(45) **Date of Patent:** **Apr. 30, 2019**

(54) **SURFACE CLEANING APPARATUS**

(2013.01); *A47L 9/1608* (2013.01); *A47L 9/1625* (2013.01); *A47L 9/1641* (2013.01); *A47L 9/1666* (2013.01); *A47L 9/1683* (2013.01); *A47L 9/2868* (2013.01); *A47L 9/2884* (2013.01); *A47L 9/322* (2013.01)

(71) Applicant: **Omachron Intellectual Property Inc.**,  
Hampton (CA)

(72) Inventor: **Wayne Ernest Conrad**, Hampton (CA)

(58) **Field of Classification Search**  
USPC ..... 15/344, 337, 327.1, 353  
See application file for complete search history.

(73) Assignee: **Omachron Intellectual Property Inc.**,  
Hampton, Ontario (CA)

(\* ) Notice: Subject to any disclaimer, the term of this patent is extended or adjusted under 35 U.S.C. 154(b) by 400 days.

(56) **References Cited**

**U.S. PATENT DOCUMENTS**

3,320,727 A \* 5/1967 Farley ..... *A47L 9/125*  
15/327.1

3,822,533 A 7/1974 Oranje  
(Continued)

(21) Appl. No.: **15/076,959**

(22) Filed: **Mar. 22, 2016**

(65) **Prior Publication Data**

US 2016/0198916 A1 Jul. 14, 2016

**Related U.S. Application Data**

(60) Continuation of application No. 14/875,381, filed on Oct. 5, 2015, now Pat. No. 9,545,181, which is a  
(Continued)

**FOREIGN PATENT DOCUMENTS**

CN 1336154 A 2/2002  
CN 1875846 A 12/2006

(Continued)

**OTHER PUBLICATIONS**

Third party observations made of record on the related United Kingdom Application No. 0911652.6, dated Jul. 14, 2010.

(Continued)

*Primary Examiner* — Joseph J Hail

*Assistant Examiner* — Shantese McDonald

(74) *Attorney, Agent, or Firm* — Philip C. Mendes da Costa; Bereskin & Parr LLP/S.E.N.C.R.L., s.r.l.

(51) **Int. Cl.**

*A47L 5/24* (2006.01)  
*A47L 5/22* (2006.01)  
*A47L 9/16* (2006.01)  
*A47L 9/32* (2006.01)  
*A47L 5/36* (2006.01)  
*A47L 9/28* (2006.01)  
*A47L 9/00* (2006.01)

(Continued)

(57) **ABSTRACT**

A hand vacuum cleaner is provided with an openable door that opens an air flow passage that extends rearwardly from an air treatment member to a suction motor.

(52) **U.S. Cl.**

CPC ..... *A47L 5/225* (2013.01); *A47L 5/24* (2013.01); *A47L 5/36* (2013.01); *A47L 5/362* (2013.01); *A47L 9/009* (2013.01); *A47L 9/125* (2013.01); *A47L 9/149* (2013.01); *A47L 9/16*

**28 Claims, 18 Drawing Sheets**

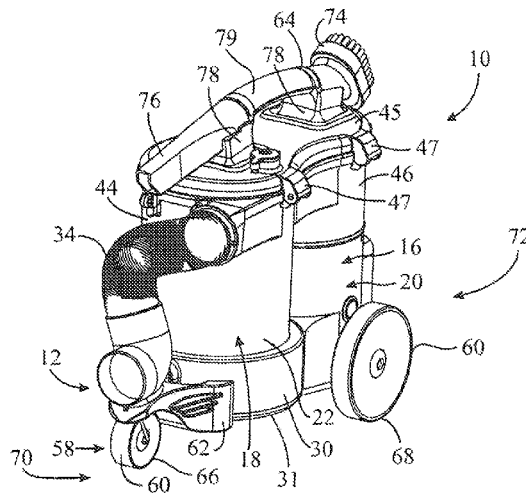

**Related U.S. Application Data**

- continuation of application No. 13/782,217, filed on Mar. 1, 2013, now Pat. No. 9,192,269, which is a continuation-in-part of application No. 13/720,754, filed on Dec. 19, 2012, now Pat. No. 8,752,239, which is a division of application No. 11/954,331, filed on Dec. 12, 2007, now Pat. No. 8,359,705.
- (60) Provisional application No. 60/870,175, filed on Dec. 15, 2006, provisional application No. 60/884,767, filed on Jan. 12, 2007.
- (51) **Int. Cl.**  
*A47L 9/12* (2006.01)  
*A47L 9/14* (2006.01)

**References Cited**

U.S. PATENT DOCUMENTS

3,877,902	A	4/1975	Eriksson et al.
4,187,088	A	2/1980	Hodgson
5,129,125	A	7/1992	Gamou et al.
5,135,552	A	8/1992	Weistra
5,267,371	A	12/1993	Soler et al.
5,779,744	A	7/1998	Mueller et al.
6,145,160	A	11/2000	Buss et al.
6,406,505	B1	6/2002	Oh et al.
6,810,558	B2	11/2004	Lee
6,840,972	B1	1/2005	Kim
7,113,847	B2	9/2006	Chmura et al.
7,278,180	B2	10/2007	Pyeong
7,377,007	B2	5/2008	Best
7,488,362	B2	2/2009	Jeong et al.
7,488,363	B2	2/2009	Jeong et al.
7,547,337	B2	6/2009	Oh et al.
7,556,661	B2	7/2009	Jeong et al.
7,604,675	B2	10/2009	Makarov et al.
7,645,309	B2	1/2010	Jeong et al.
7,887,612	B2	5/2011	Conrad
8,100,999	B2	1/2012	Ashbee et al.
8,146,201	B2	4/2012	Conrad
8,347,455	B2	1/2013	Dyson et al.
8,444,731	B2	5/2013	Gomiciaga-Pereda et al.
2004/0083694	A1	5/2004	Choi
2004/0134022	A1	7/2004	Murphy et al.
2005/0138758	A1	6/2005	Lee et al.
2006/0042039	A1	3/2006	McDowell et al.
2006/0090428	A1	5/2006	Park et al.
2006/0101610	A1*	5/2006	Oh ..... A47L 9/1683 15/327.2
2006/0137303	A1	6/2006	Jeong et al.
2006/0137304	A1	6/2006	Jeong et al.
2006/0137307	A1*	6/2006	Jeong ..... A47L 9/1625 55/337
2006/0137309	A1	6/2006	Jeong et al.
2006/0277712	A1	12/2006	Kim et al.
2007/0095028	A1*	5/2007	Kim ..... A47L 5/28 55/337
2007/0130895	A1	6/2007	Boeck et al.
2007/0143953	A1	6/2007	Hwang et al.
2007/0271724	A1	11/2007	Haekan et al.
2007/0289267	A1	12/2007	Makarov et al.
2008/0178416	A1	7/2008	Conrad
2008/0256744	A1	10/2008	David et al.
2009/0113663	A1	5/2009	Follows et al.
2009/0282639	A1	11/2009	James et al.
2009/0307864	A1	12/2009	Dyson
2010/0045215	A1	2/2010	Hawker et al.
2011/0219570	A1	9/2011	Conrad
2013/0091660	A1	4/2013	Smith
2013/0091661	A1	4/2013	Smith
2013/0091812	A1	4/2013	Smith
2013/0091813	A1	4/2013	Smith
2014/0237768	A1	8/2014	Conrad
2016/0367094	A1	12/2016	Conrad

FOREIGN PATENT DOCUMENTS

CN	1875855	A	12/2006
CN	1969739	A	5/2007
CN	1981688	A	6/2007
CN	101061932	A	10/2007
CN	101108081	A	1/2008
CN	101108106	A	1/2008
CN	101108110	A	1/2008
CN	101448447	A	6/2009
CN	101489453	A	7/2009
CN	101489455	A	7/2009
CN	101489457	A	7/2009
CN	101489461	A	7/2009
CN	101657133	A	2/2010
CN	102188208	A	9/2011
CN	102255523	A	11/2011
CN	202173358	U	3/2012
CN	202277306	U	6/2012
CN	103040412	A	4/2013
CN	103040413	A	4/2013
CN	103169420	A	6/2013
DE	112007003039	T5	10/2009
DE	112007003052	T5	1/2010
EP	0489468	A	6/1992
EP	1302148	A2	4/2003
EP	1323370	A2	7/2003
GB	2365324	A	2/2002
GB	2440111	A	1/2008
GB	2457419	A	8/2009
JP	2003033300	A	2/2003
KR	20050091824	A	9/2005
KR	20050091826	A	9/2005
KR	20050091829	A	9/2005
KR	20050091830	A	9/2005
KR	20050091833	A	9/2005
KR	20050091834	A	9/2005
KR	20050091835	A	9/2005
KR	20050091836	A	9/2005
KR	20050091837	A	9/2005
KR	20050091838	A	9/2005
KR	20050103343	A	10/2005
KR	20050104613	A	11/2005
KR	20050104614	A	11/2005
KR	20060018004	A	2/2006
WO	2005/084511	A1	9/2005
WO	2008035032	A	3/2008

OTHER PUBLICATIONS

The Office Action issued on co-pending U.S. Appl. No. 11/953,420, dated Jun. 21, 2010.

The International Preliminary Report on Patentability received on the co-pending International Application No. PCT/CA2007/002205, dated Apr. 21, 2008.

The International Preliminary Report on Patentability received on the corresponding International Application No. PCT/CA2007/002204, dated Apr. 24, 2008.

English machine translation of CN1336154A published as of Feb. 20, 2002.

English machine translation of CN1875846A published as of Dec. 13, 2006.

English machine translation of CN1875855A published as of Dec. 13, 2006.

English machine translation of CN1969739A published as of May 30, 2007.

English machine translation of CN1981688A published as of Jun. 20, 2007.

English machine translation of CN101061932A published as of Oct. 31, 2007.

English machine translation of CN101108081A published as of Jan. 23, 2008.

English machine translation of CN101108106A published as of Jan. 23, 2008.

English machine translation of CN101108110A published as of Jan. 23, 2008.

(56)

**References Cited**

OTHER PUBLICATIONS

English machine translation of CN101448447A published as of Jun. 3, 2009.  
English machine translation of CN101489453A published as of Jul. 22, 2009.  
English machine translation of CN101489455A published as of Jul. 22, 2009.  
English machine translation of CN101489457A published as of Jul. 22, 2009.  
English machine translation of CN101489461A published as of Jul. 22, 2009.  
English machine translation of CN101657133A published as of Feb. 24, 2010.  
English machine translation of CN102188208A published as of Sep. 21, 2011.  
English machine translation of CN102256523A published as of Nov. 23, 2011.  
English machine translation of CN103040412A published as of Apr. 17, 2013.  
English machine translation of CN103040413A published as of Apr. 17, 2013.  
English machine translation of CN103169420A published as of Jun. 26, 2013.  
English machine translation of CN202173358U published as of Mar. 28, 2012.  
English machine translation of CN202277306U published as of Jun. 20, 2012.  
English machine translation of DE112007003039T5 published as of Oct. 29, 2009.  
English machine translation of DE112007003052T5 published as of Jan. 14, 2010.

English machine translation of KR1020050091824A published as of Sep. 15, 2005.  
English machine translation of KR1020050091826A published as of Sep. 15, 2005.  
English machine translation of KR1020050091829A published as of Sep. 15, 2005.  
English machine translation of KR1020050091830A published as of Sep. 15, 2005.  
English machine translation of KR1020050091833A published as of Sep. 15, 2005.  
English machine translation of KR102000091834A published as of Sep. 15, 2005.  
English machine translation of KR1020050091835A published as of Sep. 15, 2005.  
English machine translation of KR1020050091836A published as of Sep. 15, 2005.  
English machine translation of KR1020050091837A published as of Sep. 15, 2005.  
English machine translation of KR1020050091838A published as of Sep. 15, 2005.  
English machine translation of KR1020050103343A published as of Oct. 31, 2005.  
English machine translation of KR1020050104613A published as of Nov. 3, 2005.  
English machine translation of KR1020050104614A published as of Nov. 3, 2005.  
English machine translation of KR1020060018004A published as of Feb. 28, 2006.  
U.S. Appl. No. 13/720,754, now U.S. Pat. No. 8,752,239.  
U.S. Appl. No. 13/782,039, now U.S. Pat. No. 9,119,513.  
U.S. Appl. No. 13/782,217, now U.S. Pat. No. 9,192,269.  
U.S. Appl. No. 14/875,381, now U.S. Pat. No. 9,545,181.  
U.S. Appl. No. 15/181,537.  
U.S. Appl. No. 15/446,587.

\* cited by examiner

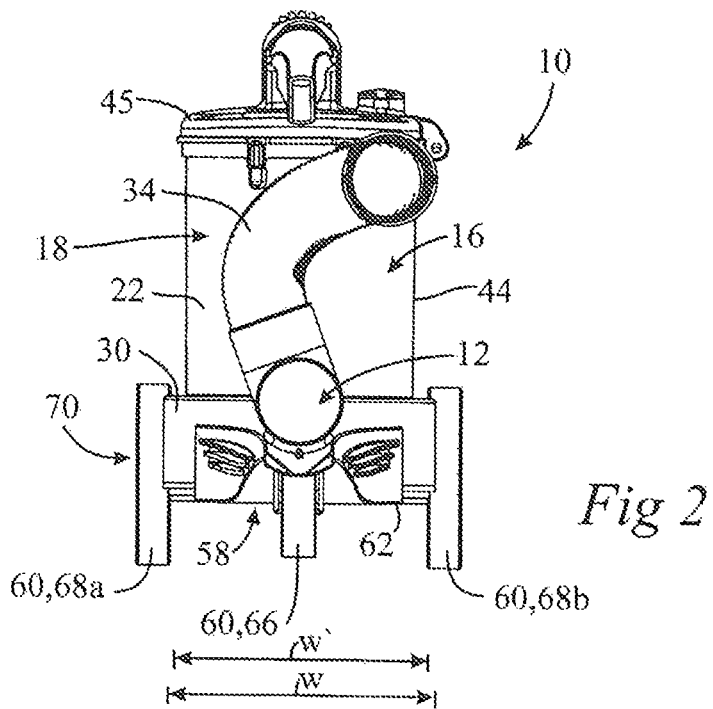
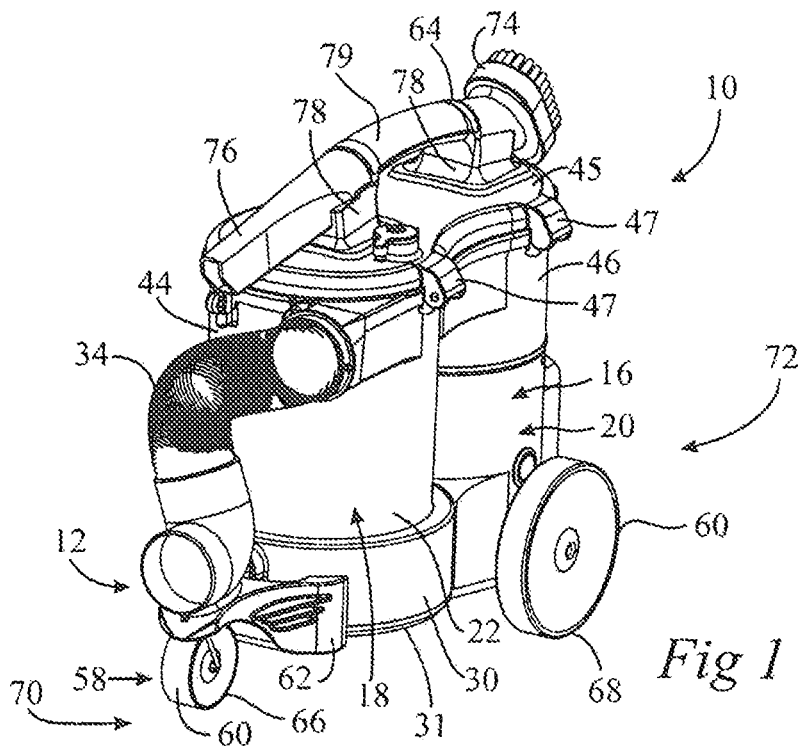

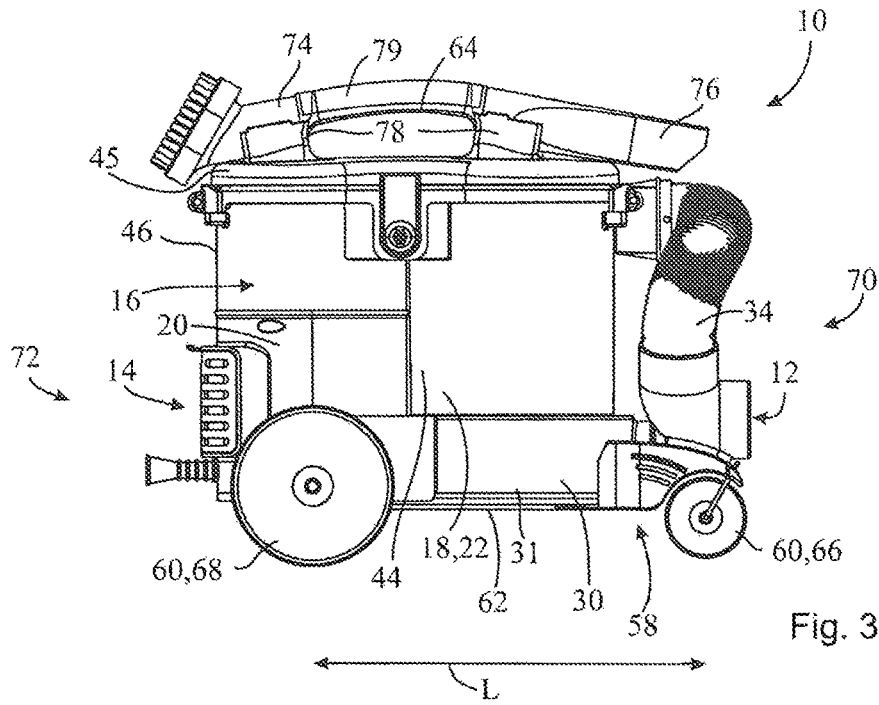

Fig. 3

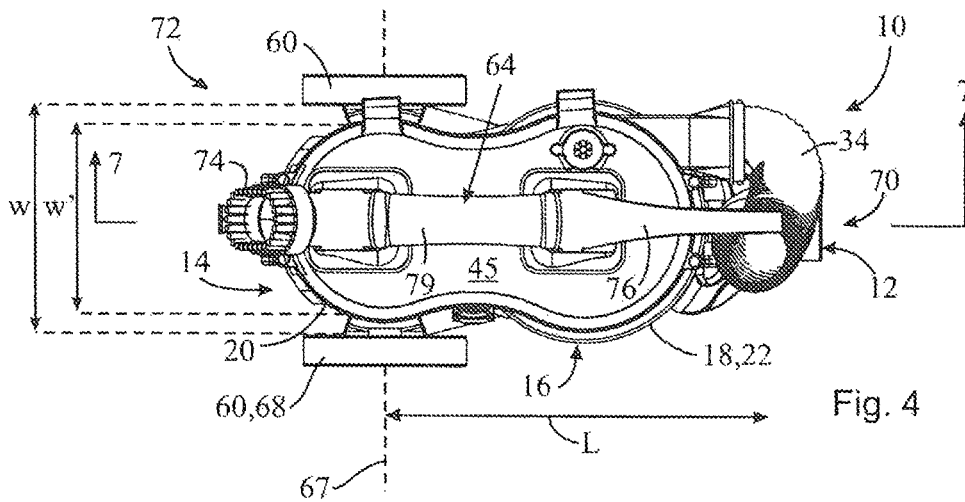

Fig. 4

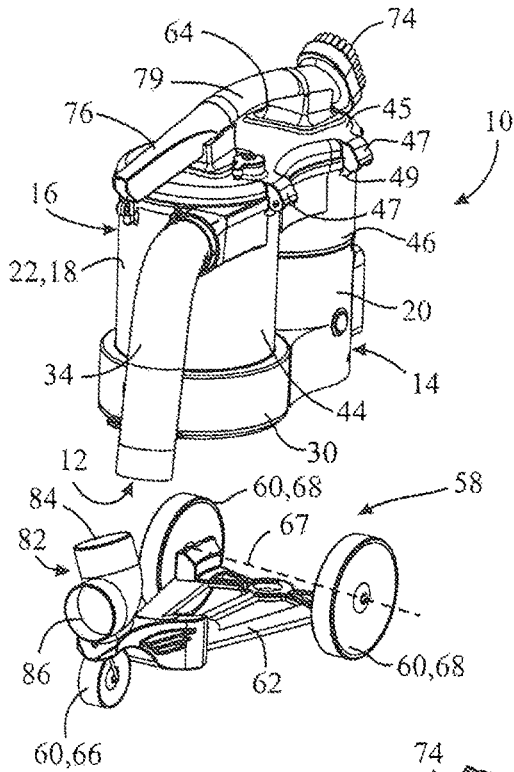

Fig. 5

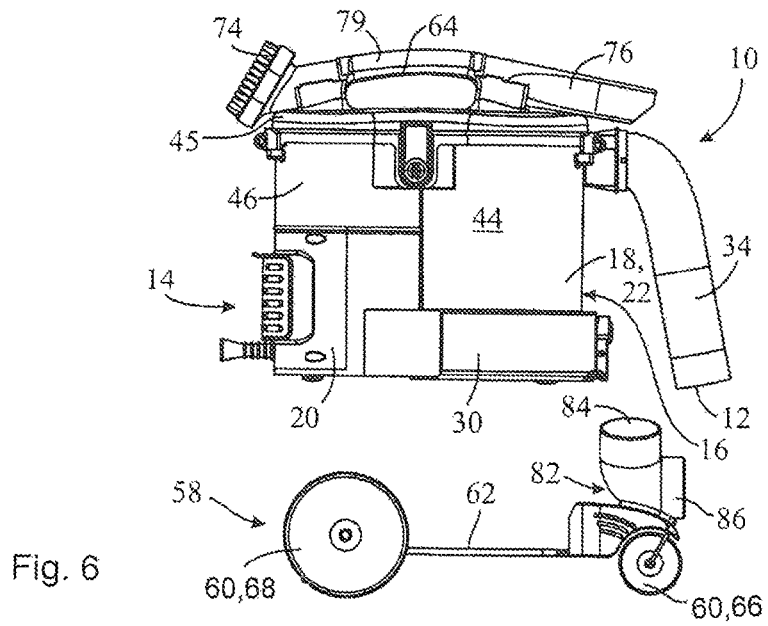

Fig. 6

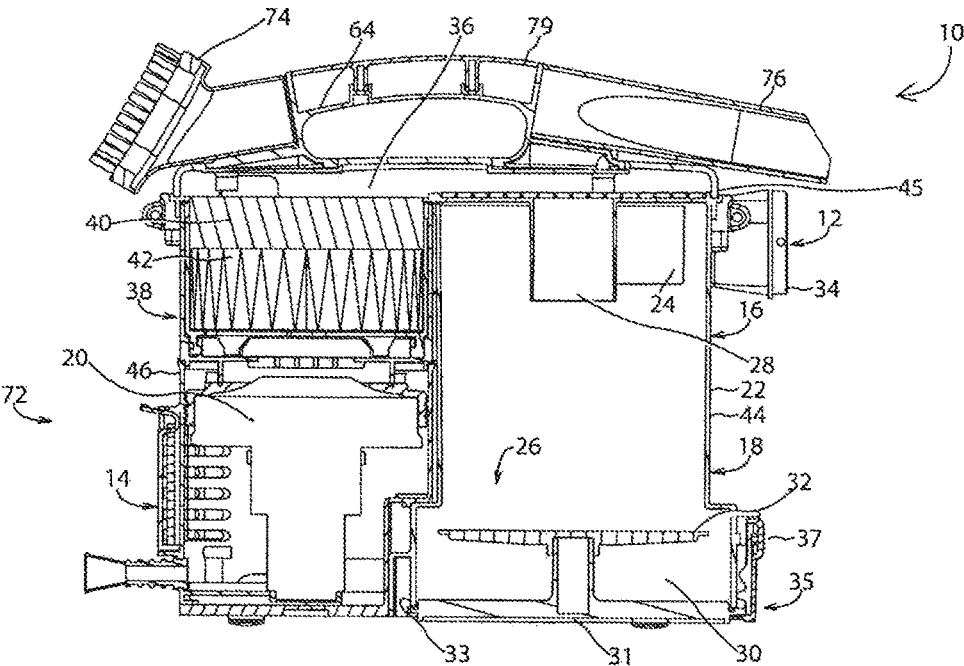

Fig. 7

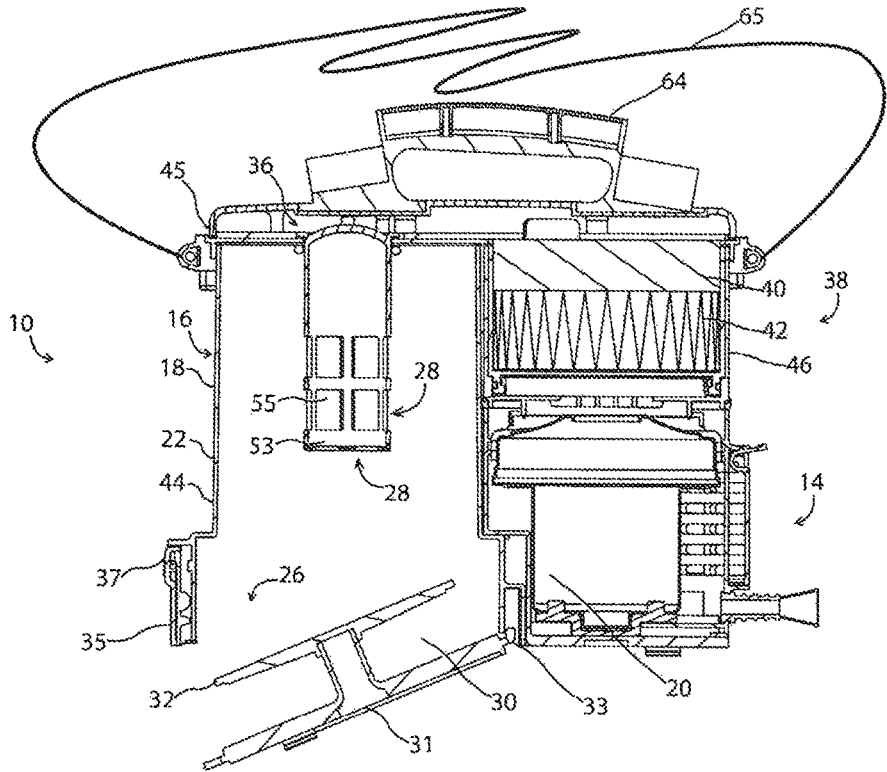

Fig. 8



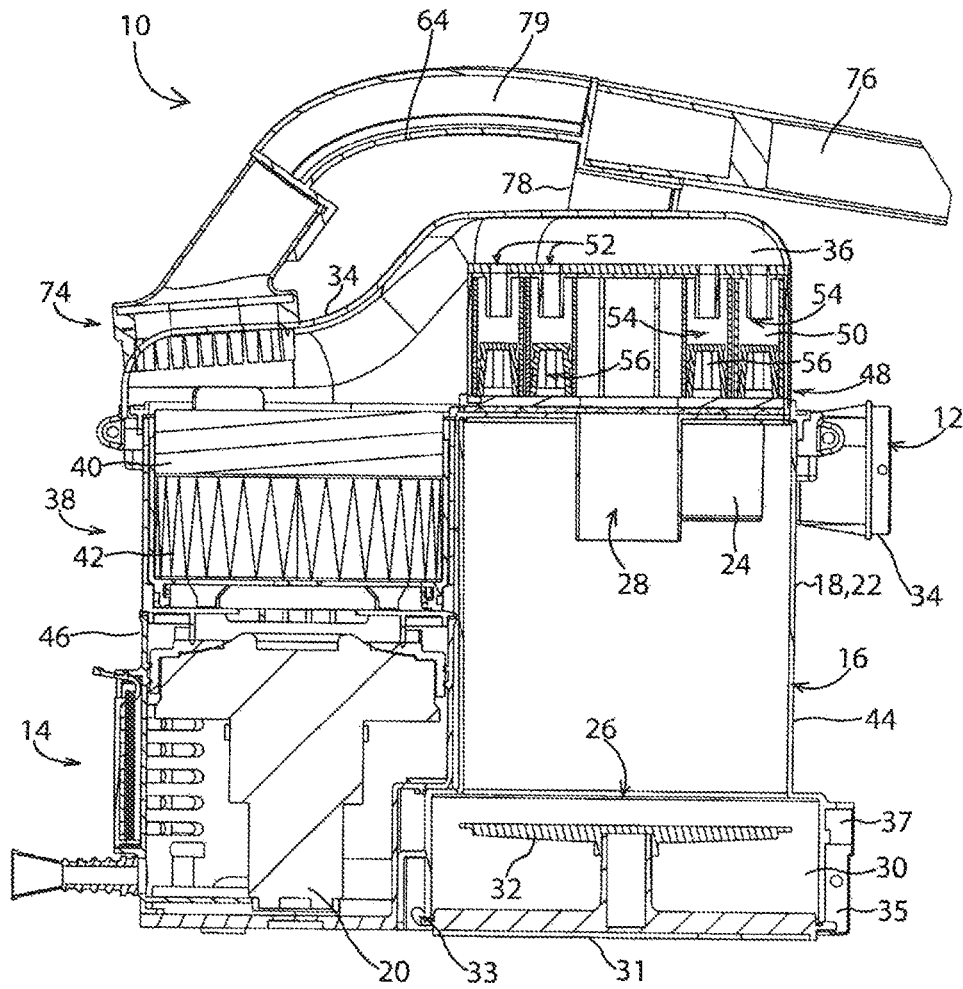

Fig. 9

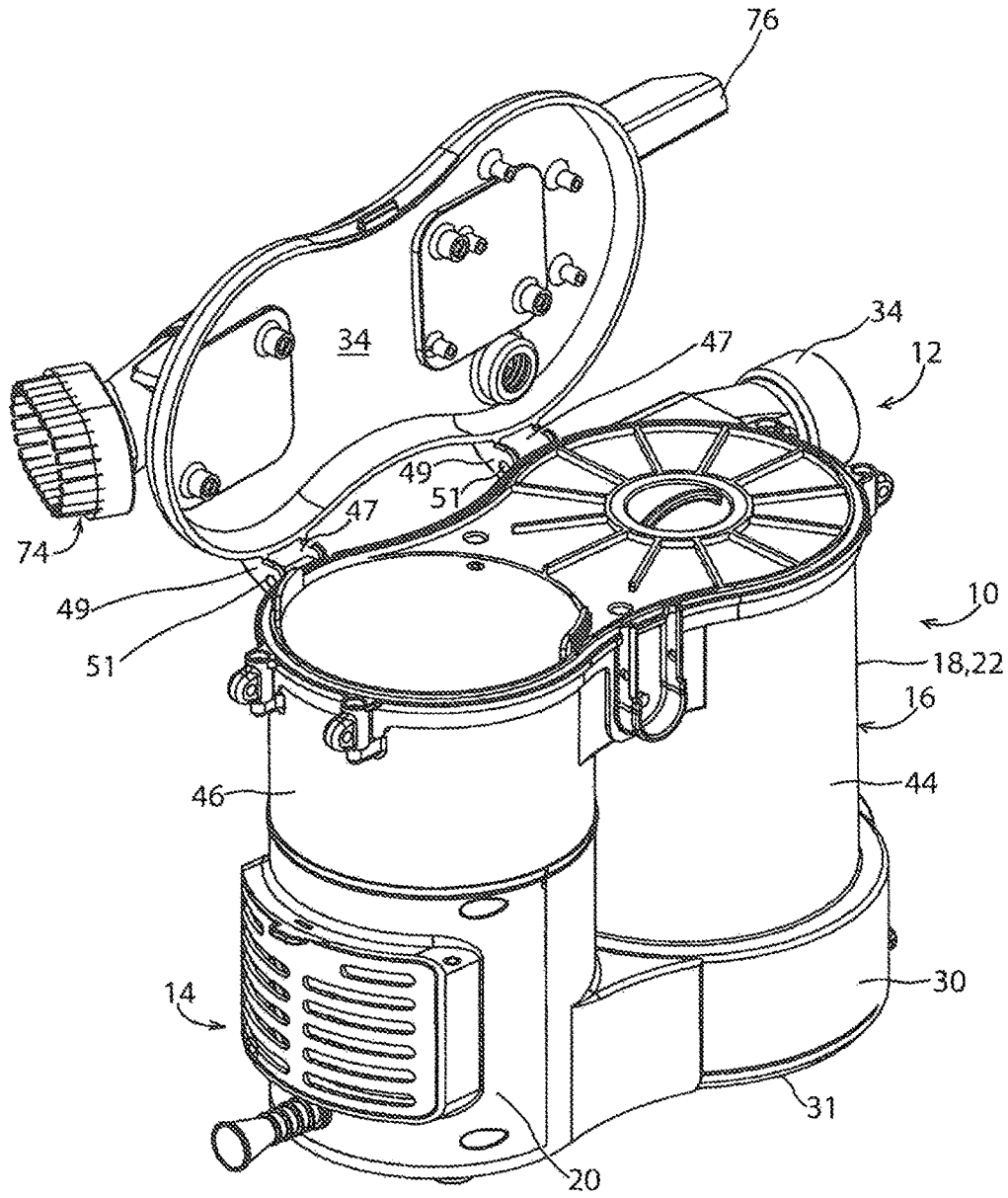

Fig. 10

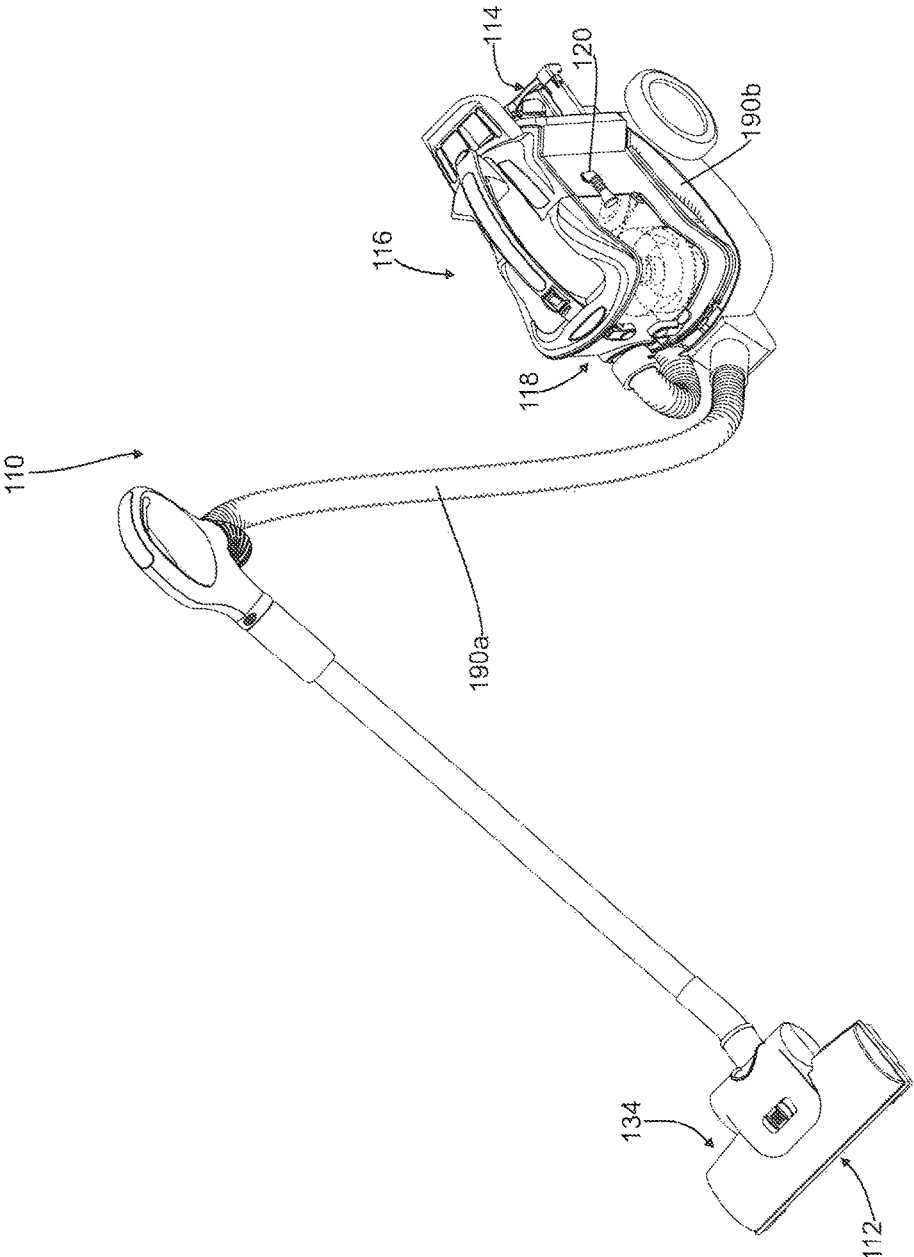

Fig. 11

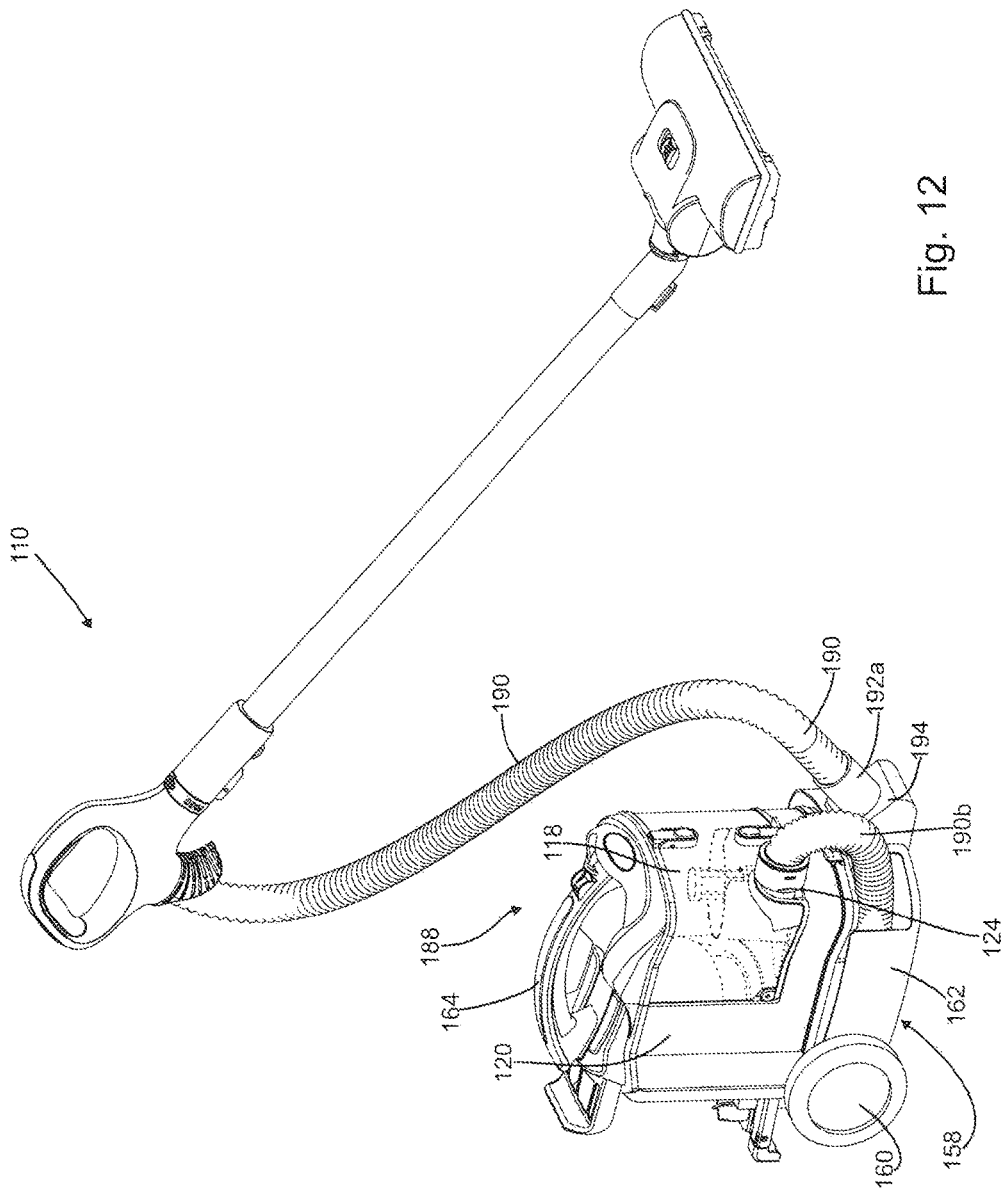

Fig. 12

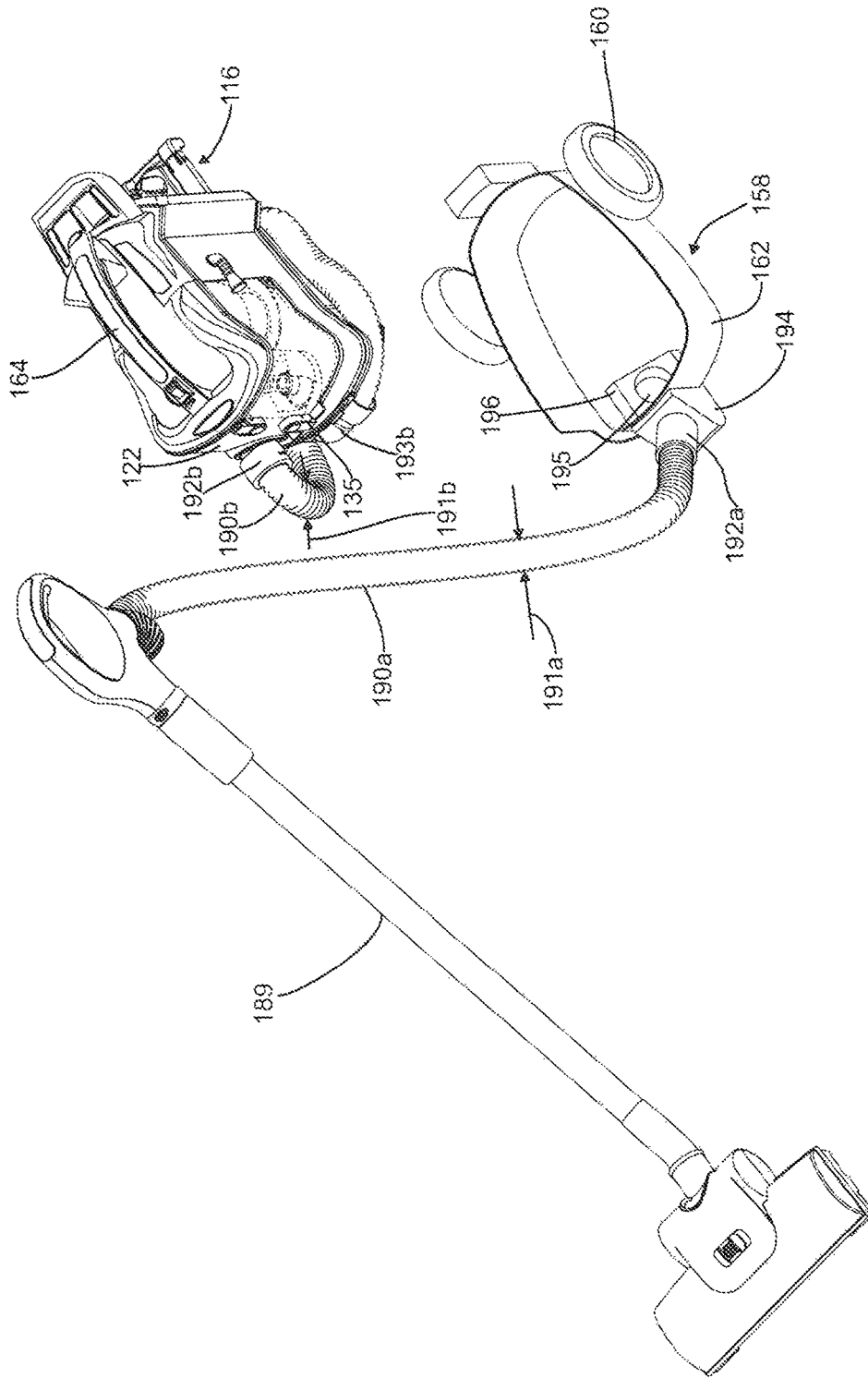

Fig. 13

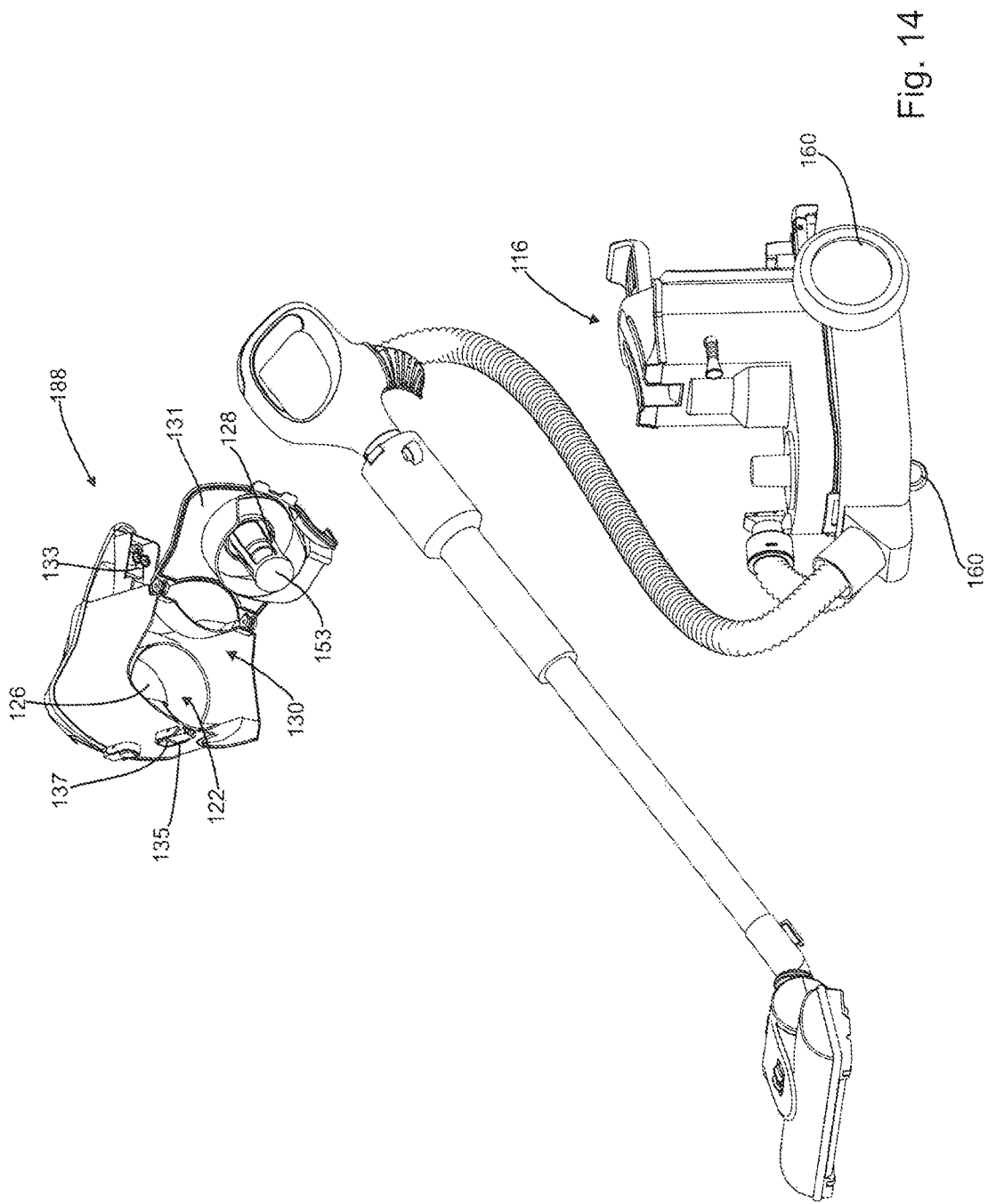

Fig. 14

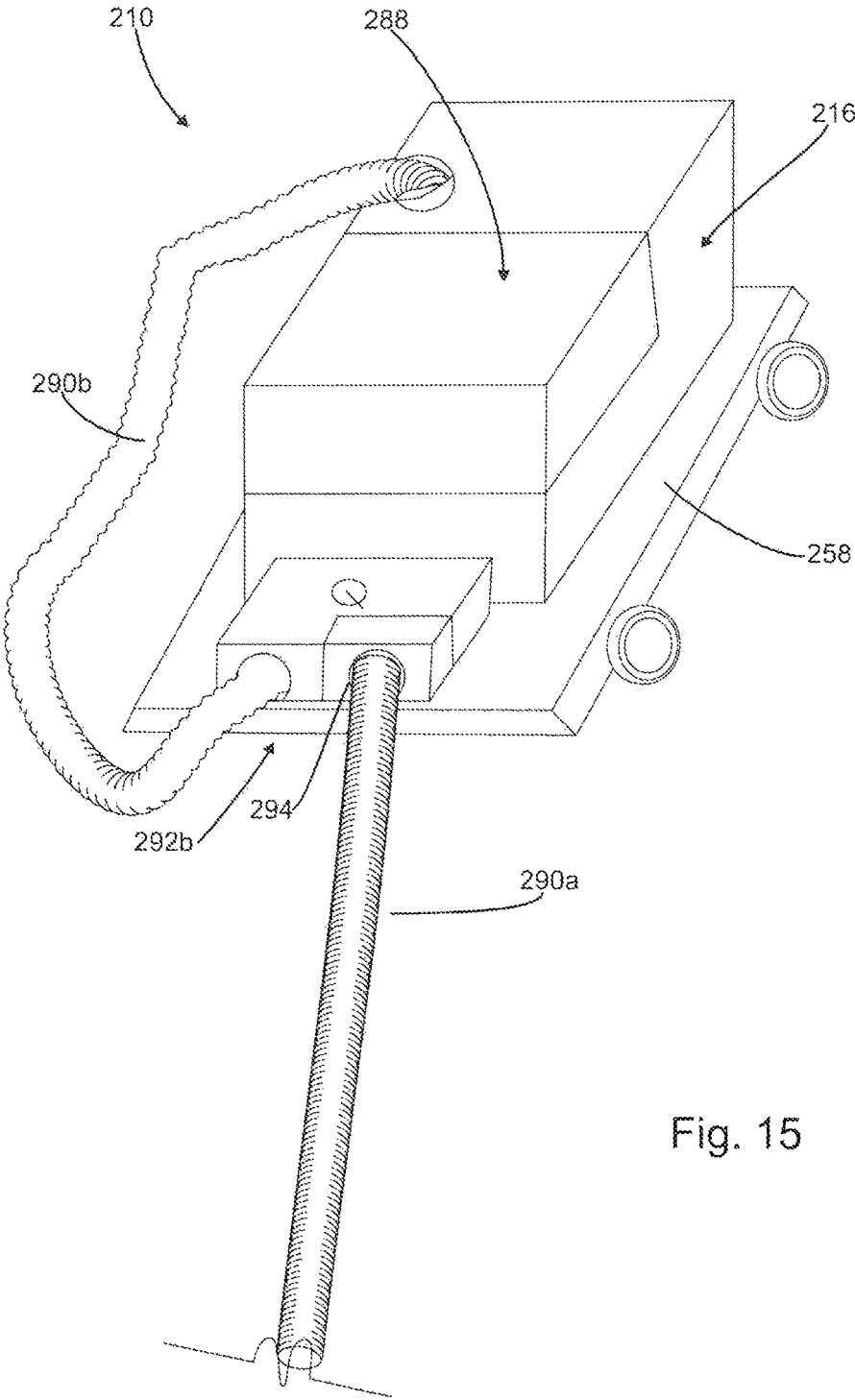

Fig. 15

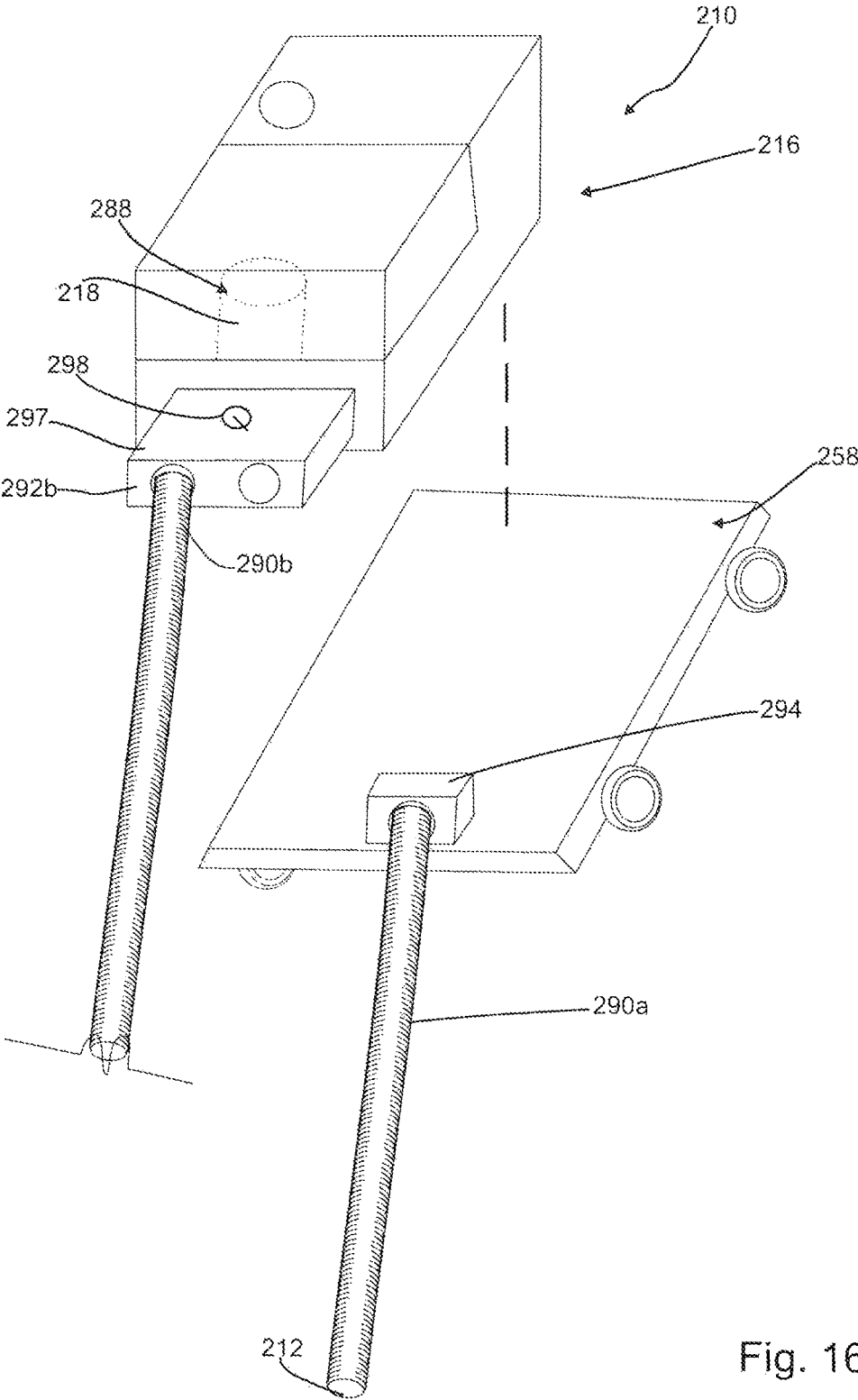

Fig. 16



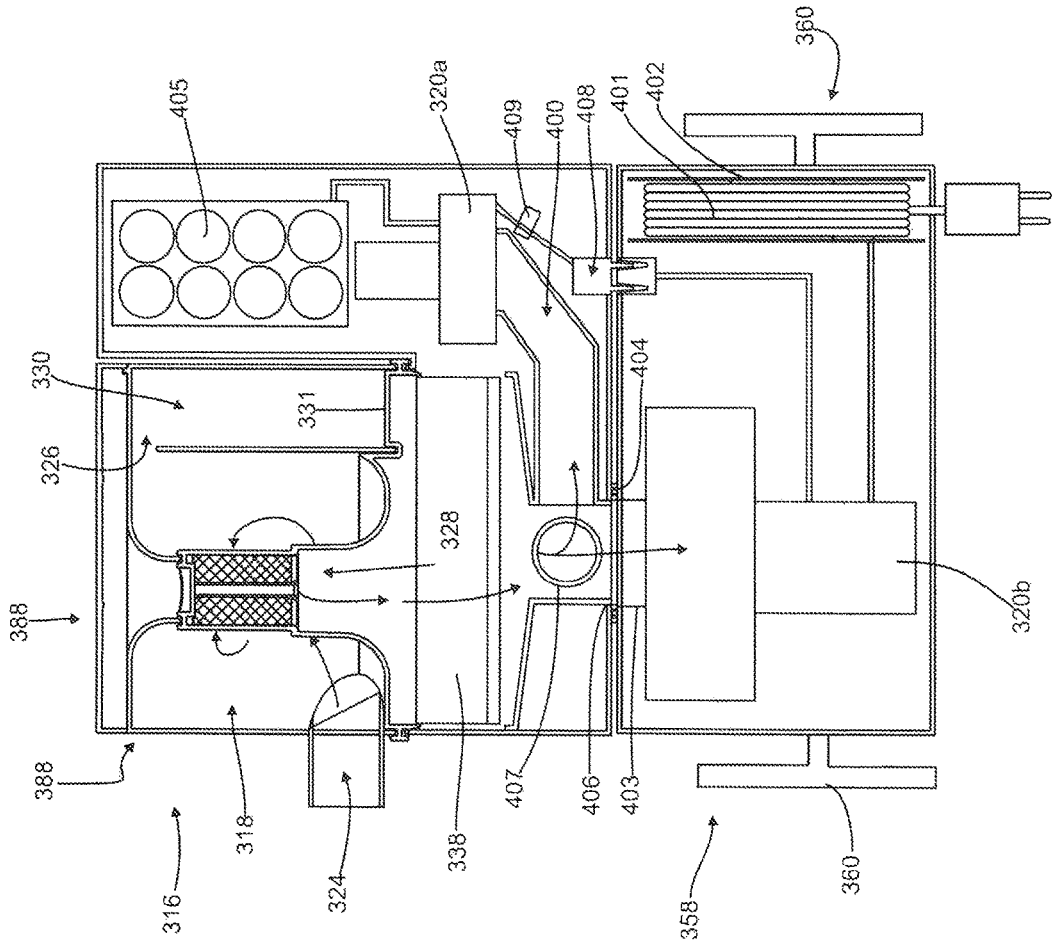

Fig. 17

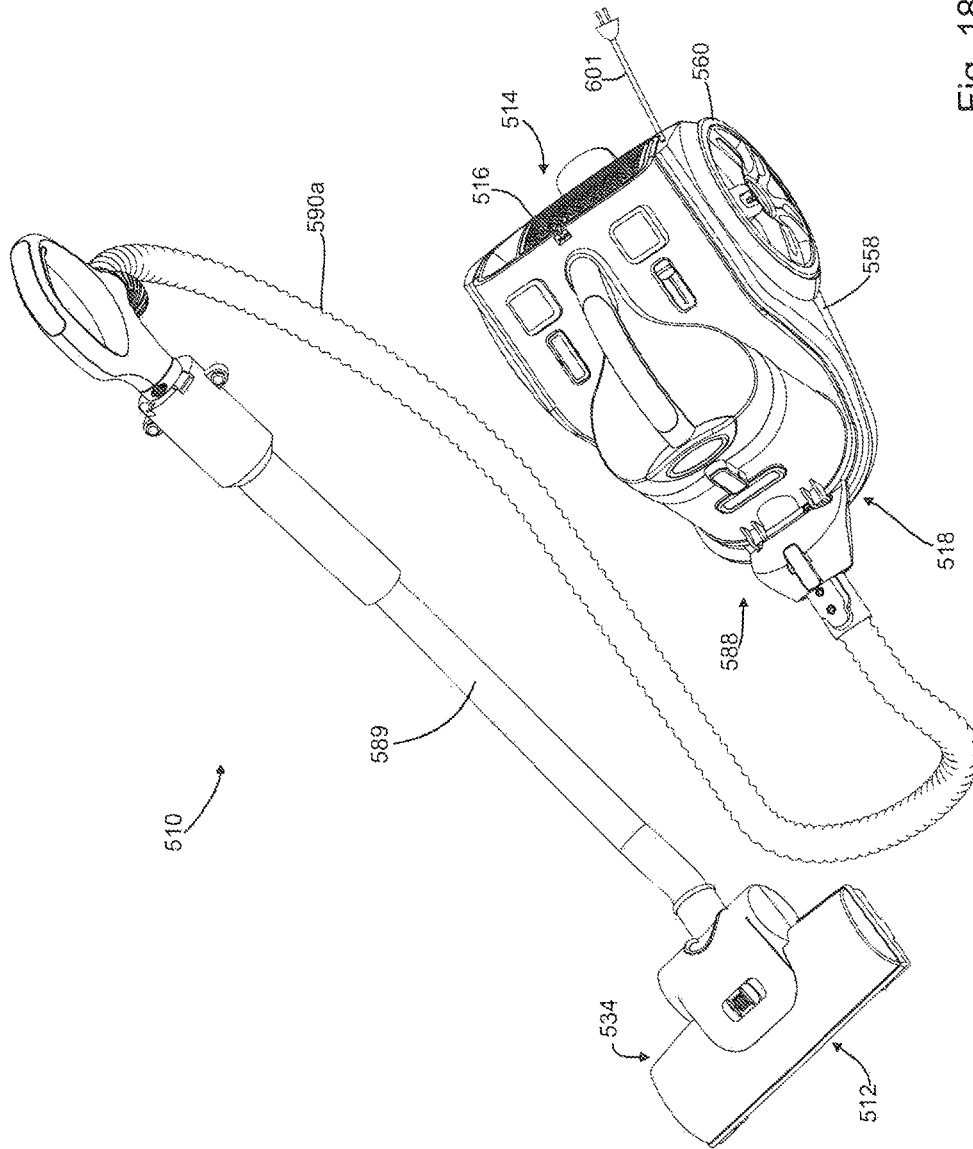

Fig. 18

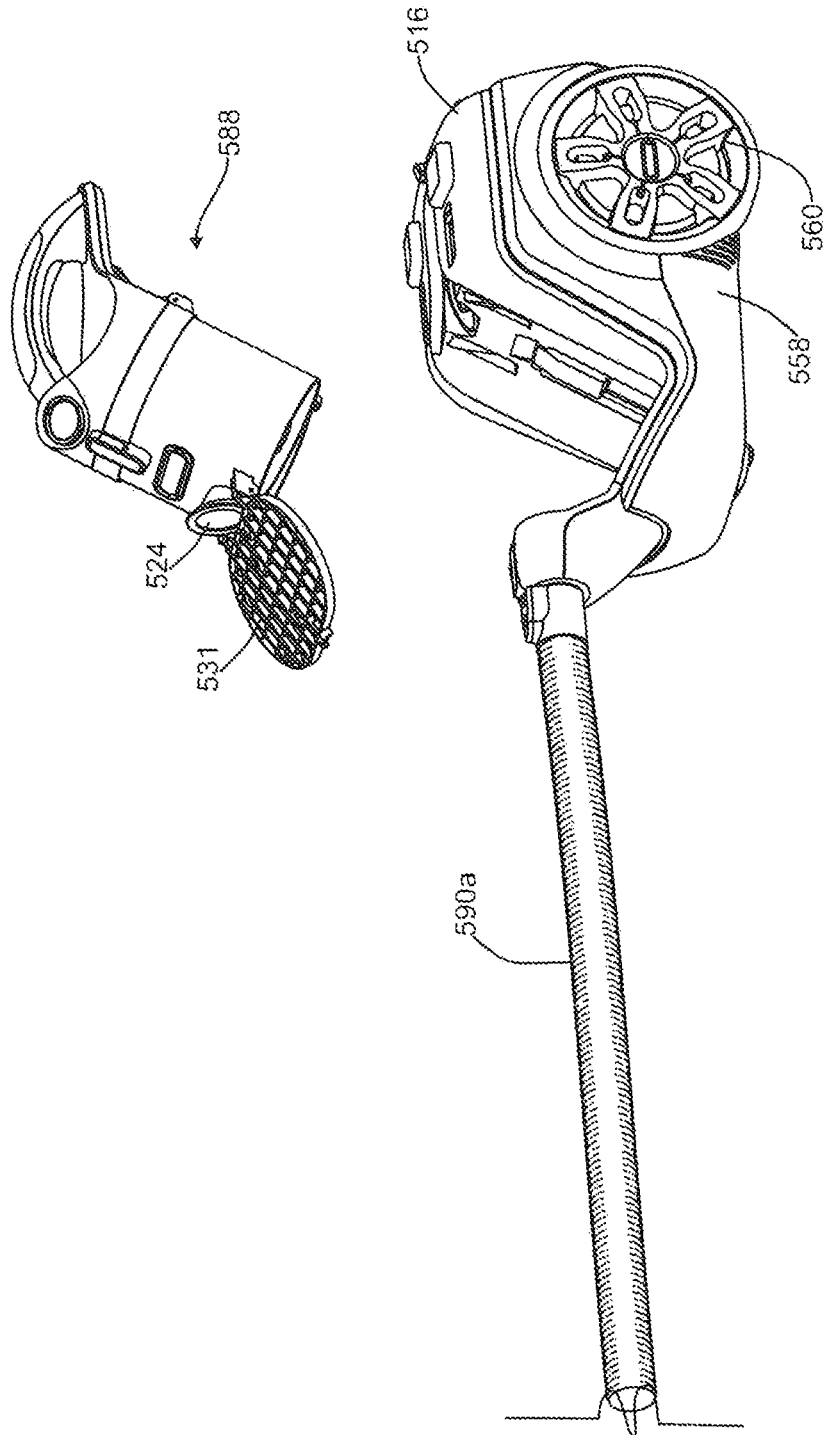

Fig. 19

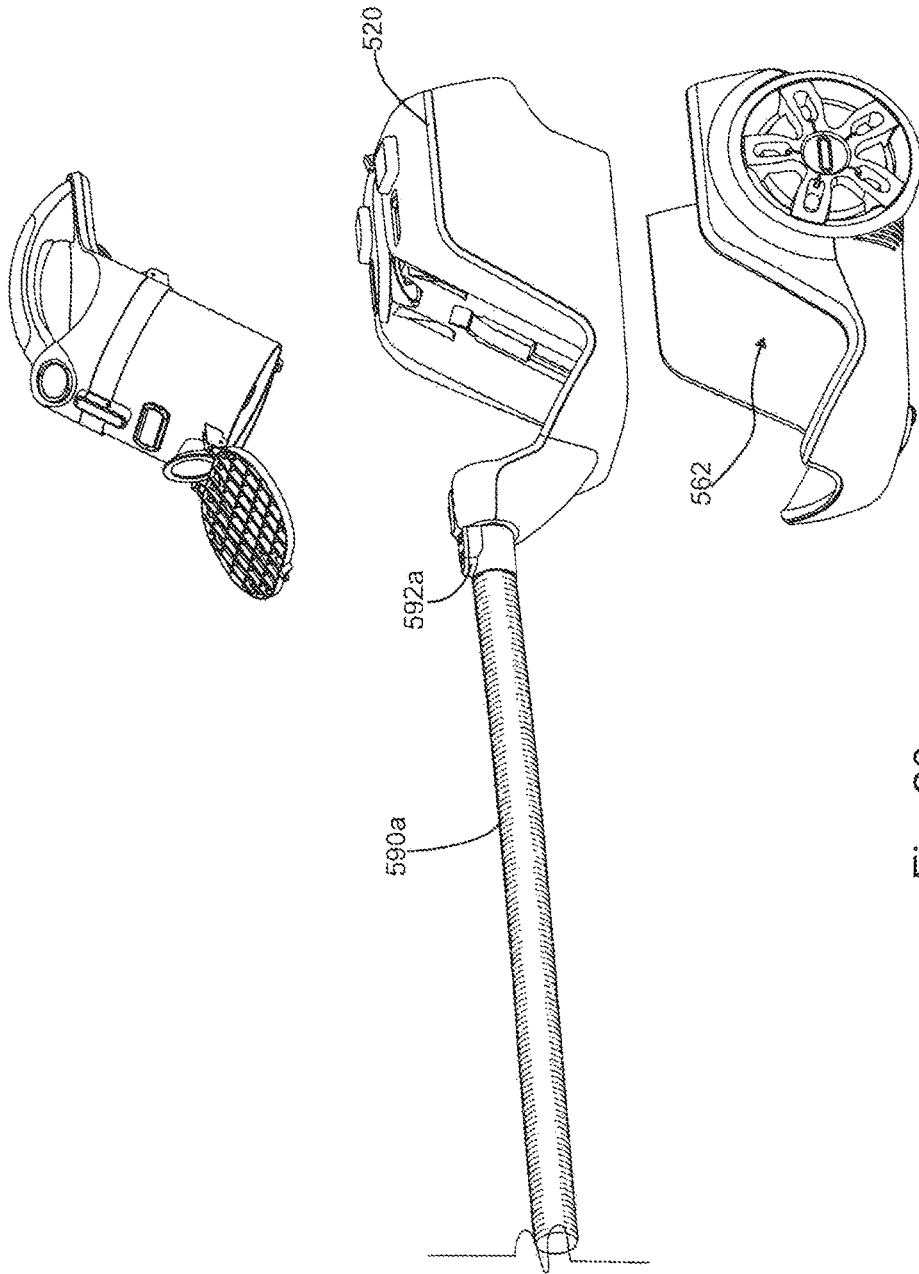

Fig. 20

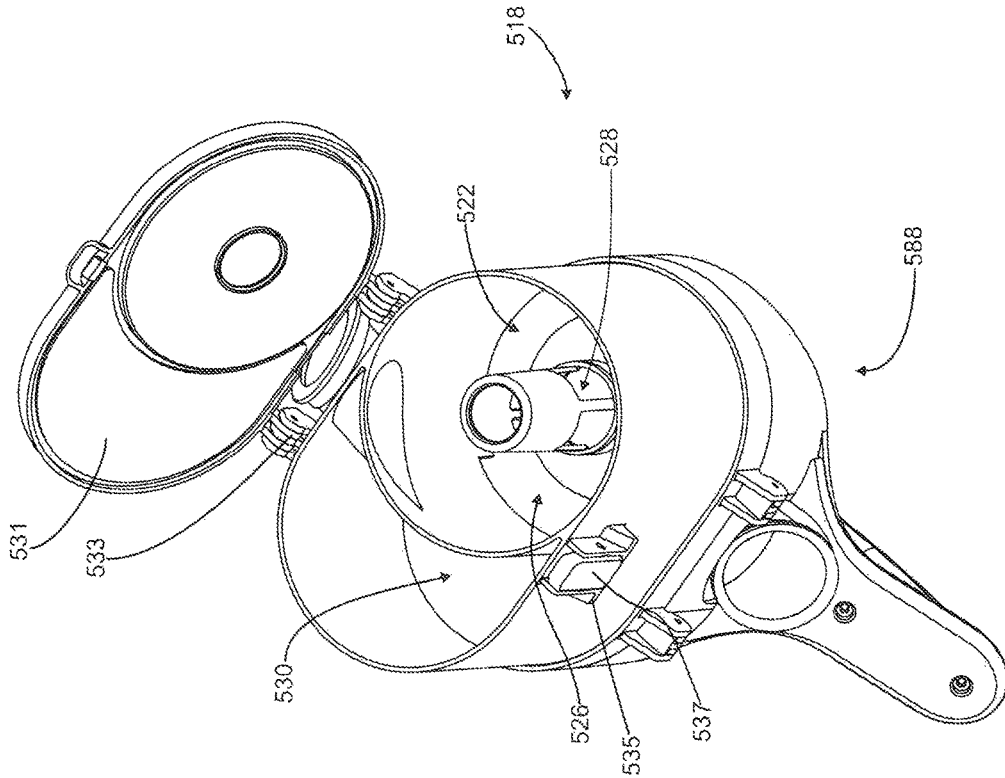

Fig. 21

## SURFACE CLEANING APPARATUS

## CROSS-REFERENCE TO RELATED APPLICATIONS

This application claims the benefit under 35 USC 120 as a continuation application of co-pending U.S. patent application Ser. No. 14/875,381 which was filed on Oct. 5, 2015, which itself is a continuation of U.S. patent application Ser. No. 13/782,217, filed on Mar. 1, 2013, which issued as U.S. Pat. No. 9,192,269 on Nov. 24, 2015, which itself is a continuation in part of U.S. patent application Ser. No. 13/720,754, filed on Dec. 19, 2012, which issued as U.S. Pat. No. 8,752,239 on Jun. 17, 2014, which itself is a divisional application of U.S. patent application Ser. No. 11/954,331, filed on Dec. 12, 2007, which issued as U.S. Pat. No. 8,359,705 on Jan. 29, 2013, which itself claims priority from U.S. Provisional Patent applications 60/870,175 (filed on Dec. 15, 2006), and 60/884,767 (filed on Jan. 12, 2007), all of which are incorporated herein by reference in their entirety.

## FIELD

This specification relates to a surface cleaning apparatus comprising a base with a removable portable surface cleaning unit such as a pod or other hand carryable surface cleaning apparatus wherein the portable surface cleaning apparatus is usable when mounted on the base or when removed therefrom.

## INTRODUCTION

The following is not an admission that anything discussed below is part of the prior art or part of the common general knowledge of a person skilled in the art.

Various types of surface cleaning apparatuses are known in the art. Such surface cleaning apparatuses include vacuum cleaners, including upright vacuum cleaners, hand carryable vacuum cleaners, canister type vacuum cleaners, and Shop-Vac™ type vacuum cleaners. Some such vacuum cleaners are provided with wheels. For example, typical upright vacuum cleaners are provided with a surface cleaning head that includes wheels mounted to a bottom surface thereof. Upright vacuum cleaners are easy for a consumer to use since the consumer does not have to carry the vacuum cleaner but merely push it over a surface. However, depending on the size of the surface cleaning head, an upright vacuum cleaner may not be useable in smaller or crowded areas. Canister vacuum cleaners have a flexibly hose extending between a surface cleaning head and the canister body, thereby improving mobility of the cleaning head. However, consumers must separately move a canister body, which can add an extra step during the cleaning process.

## SUMMARY

This summary is intended to introduce the reader to the more detailed description that follows and not to limit or define any claimed or as yet unclaimed invention. One or more inventions may reside in any combination or sub-combination of the elements or process steps disclosed in any part of this document including its claims and figures.

According to one broad aspect of this invention, a surface cleaning apparatus comprises a portable cleaning unit, which may be carried by hand or a shoulder strap such as a pod, which is removably mounted on a wheeled base. The

portable cleaning unit may be provided with a suction motor and an energy storage member (such as batteries). Accordingly, the suction motor of the portable cleaning unit may be operable on DC current. However, in accordance with this embodiment, the wheeled base may include a second suction motor (e.g. an AC powered suction motor). Accordingly, when the portable cleaning unit is provided on the wheeled base and the wheeled base is connected to a source of current, the suction motor in the wheeled base may be operated, e.g. on AC current, and used to draw air through an airflow path to the air treatment member in the portable cleaning unit. An advantage of this design is that the suction motor provided in the wheeled base may produce a higher airflow and therefore increase cleanability when the portable cleaning unit is provided on the wheeled base. However, when the portable cleaning unit is removed from the wheeled base, a smaller and lighter suction motor is utilized. While the velocity of the airflow through the portable cleaning unit when removed from the base may be decreased, the reduced weight of the suction motor may be beneficial. In addition, a smaller airflow path may be provided when the portable cleaning unit is removed from the base, and, accordingly, a smaller DC power suction motor may provide substantially similar airflow in the hand carryable mode.

The portable cleaning unit may comprise at least one cyclonic separation stage and a suction motor. Accordingly, the portable cleaning unit is useable, e.g., as a vacuum cleaner or the like, when removed from the wheeled base. The cyclonic separation stage comprises a cyclone chamber and a material collection chamber. The portable cleaning unit is configured such that the material collection chamber is removable for emptying when the portable cleaning unit is mounted on the wheeled base. For example, the material collection chamber may be removed by itself when the portable cleaning unit is mounted on the wheel base. Alternately, the material collection chamber and the cyclone chamber may be removable as a unit (e.g. a cyclone bin assembly). It will be appreciated that the material collection chamber, either by itself or in conjunction with the cyclone chamber and possibly other elements, may be removable from the portable cleaning unit when the portable cleaning unit has been removed from the wheeled base. An advantage of this design is that the usability of the surface cleaning apparatus is increased. In particular, when it is needed to empty the dirt collection chamber, all that is needed is to remove the dirt collection chamber either by itself, or, for example, together with the cyclone chamber for emptying. Accordingly, a user did not carry the weight of the motor when the user is emptying the dirt collection chamber.

Preferably, in accordance with this embodiment, the dirt collection chamber and, optionally, the cyclone chamber may be provided on an upper portion of the portable cleaning unit so as to be removable upwardly therefrom.

It will be appreciated by a skilled person in the art that any of the features of the configuration of a portable cleaning unit to permit a dirt collection chamber to be removed from the portable cleaning unit when the portable cleaning unit is mounted on the wheeled base as discussed herein may not be utilized with dual motor design disclosed herein, but may be used by itself or in combination with any other feature disclosed herein.

In accordance with another embodiment, the portable cleaning unit may be provided with a pod hose which is removable with the portable cleaning unit from the wheeled base. The pod hose may have a smaller diameter and, accordingly, may be used only when the portable cleaning

3

unit has been removed from the wheeled base. Accordingly, when the portable cleaning unit is on a wheeled base, the pod hose does not form part of the fluid flow path. Accordingly, the smaller diameter of the pod hose does not restrict the airflow path when the portable cleaning unit is placed on a wheeled base. An advantage of this design is that the portable cleaning unit may carry a longer hose without increasing the volume taken by the pod hose. In addition, the pod hose, being a smaller diameter, may be more flexible and enhance the usability of the portable cleaning unit in a hand-carriable mode. For example, the pod hose may have a greater stretch ratio, for example, of 4:1 to 7:1 or more.

In accordance with this embodiment, a valve may be provided on the portable cleaning unit whereby the pod hose is not in airflow communication with the suction motor when the portable cleaning unit is mounted on the wheeled base. However, when the portable cleaning unit is removed from the wheeled base, the valve may be actuated (e.g. automatically upon removal of the portable cleaning unit from the wheeled base, manually by the user or automatically when the hose is deployed for use) such that pod hose forms part of the air flow path.

It will be appreciated by a person skilled in the art that any of the features of the pod hose which are discussed herein may not be utilized with the dual motor design disclosed herein, but may be used by itself or in combination with any other feature disclosed herein.

In accordance with another embodiment, the portable cleaning unit may be operable by AC power supplied to the base when the portable cleaning unit is mounted on the base and may be operable on DC power when the portable cleaning unit is removed from the base. Accordingly, the portable cleaning unit may include an energy storage member (e.g. one or more batteries) which may power the suction motor when the portable cleaning unit is removed from the base. Accordingly, the suction motor may be operable on DC current. When the pod is mounted on the wheeled base, and the wheeled base is connected to a source of current by an electrical cord, then the suction motor may be in electrical communication with the base so as to be powered by AC current supplied through the electrical cord. For example, the suction motor could have dual winding so as to be operable on both AC and DC current. Alternately, the base may include a power supply to convert the AC current to DC current which is then supplied to the suction motor when the portable cleaning unit is placed on the base. For example, the power supply may comprise an inverter.

In this particular embodiment, it will be appreciated that the batteries in the portable cleaning unit may be charged while the portable cleaning unit is mounted on the wheeled base and the wheeled base is plugged into an electrical outlet.

In a further alternate embodiment, instead of utilizing electricity from an electrical outlet, the wheeled base may include a fuel cell or an alcohol-powered internal or external combustion engine. In such an embodiment, the wheeled base may produce AC current or DC current, which is then supplied to the suction motor when the portable cleaning unit is mounted on the wheeled base and actuated.

It will be appreciated by a person skilled in the art that any of the features of a portable cleaning unit which is operable on AC and DC current as disclosed herein may not be utilized with the dual motor design disclosed herein, but may be used by itself or in combination with any other feature disclosed herein.

In accordance with the further embodiment, the portable cleaning unit may comprise both an energy storage member

4

and a power supply. Accordingly, when the portable cleaning unit is connected to a power source (e.g. a cord extends from the portable cleaning unit to an electrical outlet), AC power may be supplied to the power supply (e.g. an inverter) to convert the AC current to DC which is then utilized to power the suction motor. When a user is unable to or does not want to plug the portable cleaning unit into a wall outlet, the portable cleaning unit may be powered by the energy storage member (e.g. batteries), which provide DC current to a suction motor. Accordingly, the portable cleaning unit may be powered by both AC current from a wall outlet and DC current supplied by batteries as may be desired. In a further alternate embodiment, the suction motor may be provided with two windings. In such a case, the power supply is not required and the suction motor may be powered by both DC current from the batteries and AC current from a wall outlet.

It will be appreciated by a person skilled in the art that any of the features of a pod operable with both AC and DC current as discussed herein may not be utilized with dual motor design disclosed herein, but may be used by itself or in combination with any other feature disclosed herein.

In one embodiment, there is provided a surface cleaning apparatus comprising

(a) a wheeled base comprising an AC suction motor;

(b) a portable cleaning unit removably mounted on the wheeled base and comprising at least one cyclonic separation stage, a first energy storage member and a portable cleaning unit suction motor that is operable on DC power; and,

(c) a fluid flow path extending from a first dirty fluid inlet to a clean air outlet of the surface cleaning apparatus,

wherein the AC suction motor provides motive power to move fluid through the fluid flow path when the surface cleaning unit is switched on and when the portable cleaning unit is mounted on the wheeled base, and

wherein the portable cleaning unit suction motor provides motive power to move fluid through the fluid flow path when the portable cleaning unit is switched on and when the portable cleaning unit is removed from the wheeled base.

In some embodiments, the wheeled base may further comprise or be connectable to a power cord and the portable cleaning unit is powered solely by the first energy storage member when the portable cleaning unit is removed from the wheeled base.

In some embodiments, the wheeled base may further comprise or be connectable to a power cord, the first energy storage member comprises batteries and the batteries are charged when the portable cleaning unit is mounted on the wheeled base.

In some embodiments, the suction motor in the portable cleaning unit may not be used to provide motive power to move fluid through the fluid flow path when the surface cleaning unit is switched on and when the portable cleaning unit is mounted on the wheeled base.

In some embodiments, the fluid flow path may comprise an upstream portion that extends from the first dirty fluid inlet to the portable cleaning unit and the AC suction motor is in the fluid flow path.

In some embodiments, the fluid flow path may comprise a downstream fluid flow path extending through the portable cleaning unit to the clean air outlet and the portable cleaning unit suction motor is in the downstream fluid flow path.

In some embodiments, the portable cleaning unit may comprise a flexible hose having a second dirty fluid inlet and the flexible hose is part of the downstream fluid flow path when the portable cleaning unit is removed from the wheeled base.

5

In some embodiments, the flexible hose may be an electrified flexible hose.

In some embodiments, the wheeled base may further comprise a second energy storage member.

In some embodiments, the second energy storage member may charge the first energy storage member when the portable cleaning unit is mounted on the wheeled base.

In some embodiments, the portable cleaning unit suction motor may be a DC motor.

In one embodiment, there is provided a surface cleaning apparatus comprising

(a) a wheeled based connectable to a source of current;

(b) a portable cleaning unit removably mounted on the wheeled base and comprising at least one cyclonic separation stage, a first energy storage member and a portable cleaning unit suction motor that is operable on DC power; and,

(c) a fluid flow path extending from a first dirty fluid inlet to a clean air outlet of the surface cleaning apparatus,

wherein the portable cleaning unit suction motor is operable on DC power when removed from the wheeled base and is operable on power provided by the wheeled base when mounted on the wheeled base.

In some embodiments, the portable cleaning unit suction motor may be a DC motor.

In some embodiments, the wheeled base may further comprise or is connectable to a power cord and the portable cleaning unit is powered solely by the first energy storage member when the portable cleaning unit is removed from the wheeled base.

In some embodiments, the wheeled base may further comprise or is connectable to a power cord, the first energy storage member comprises batteries and the batteries are charged when the portable cleaning unit is mounted on the wheeled base.

In some embodiments, the wheeled base may further comprise or is connectable to a power cord, the wheeled base further comprises a circuit that receives AC current and outputs DC current and the portable cleaning unit is powered the DC current when the portable cleaning unit is mounted on the wheeled base.

In some embodiments the portable cleaning unit suction motor may operate at a first power level when removed from the wheeled base and at a second power level when is mounted on the wheeled base.

In some embodiments the first power level may be less than the second power.

In accordance with another aspect, a surface cleaning apparatus, preferably a canister or Shop-Vac™ style vacuum cleaner is provided which comprises a portable cleaning unit and a wheeled base. Preferably, the cleaning unit is removably mounted to the wheeled base. Alternately, or in addition, the wheeled base has wheels mounted outward of the wheeled base, and which are preferably of a larger diameter (e.g., 1-3 inches in diameter, preferably 1.5-2.5 inches in diameter).

According to this aspect, the surface cleaning apparatus may comprise a member having a dirty fluid inlet. A fluid flow path extends from the dirty fluid inlet to a clean air outlet of the surface cleaning apparatus. The surface cleaning apparatus further comprises a wheeled based. A portable cleaning unit is removably mounted on the wheeled base and comprising at least one cyclonic separation stage and a suction motor positioned in the fluid flow path.

Embodiments in accordance with this broad aspect may be advantageous because the surface cleaning apparatus may have increased maneuverability. That is, the surface cleaning

6

apparatus may be used as a wheel mounted surface cleaning apparatus when convenient for a user since the user need not carry the surface cleaning apparatus, or as a hand or strap carryable surface cleaning apparatus, such as when a stairs or a smaller or crowded area is to be cleaned, according to the user's preference.

In some embodiments, the at least one cyclonic separation stage may comprise a cyclone chamber having at least one material outlet, a divider plate associated with the material outlet and an associated material collection chamber in flow communication with the material outlet.

In some embodiments, the material collection chamber may be positioned below the material outlet. In a further embodiment, the divider plate may be positioned in the material outlet.

In some embodiments, the material collection chamber may be moveable relative to the cyclone chamber. In a further embodiment the material collection chamber may be removable from the at least one cyclone chamber.

In some embodiments, the material collection chamber may have a portion that is openable. In a further embodiment, the portion that is openable may be a bottom wall. Such embodiments may be advantageous because the wheeled base may prevent accidental opening of the material collection chamber.

In some embodiments, the suction motor may be positioned laterally spaced from the at least one cyclonic separation stage. Accordingly, the surface cleaning apparatus may have a relatively wide stance and low center of mass, and therefore may have increased stability.

In some embodiments, the cleaning unit has a front end having the dirty fluid inlet and the front end of the cleaning unit is positioned at a front end of the wheeled base and the suction motor is positioned rearward of the at least one cyclonic separation stage.

In some embodiments, the wheeled base may have a length greater than its width. In further embodiments, the wheeled base may be generally polygonal, and preferably generally triangular in shape. Such embodiments may be advantageous because the surface cleaning apparatus may have both increased maneuverability and increased stability.

In some embodiments, the wheeled base may have at least one front wheel and at least two rear wheels, the rear wheels may have a larger diameter than the at least one front wheel and the at least one front wheel may be steerable. Such embodiments may be advantageous because the larger rear wheels may provide the wheeled base with increased stability, and the steerable front wheel may provide the wheeled base with increased maneuverability. Alternately, the front wheels may have a larger diameter or essentially the same diameter as the rear wheels.

In some embodiments, the wheeled base may have at least one front wheel and at least two rear wheels and the rear wheels may have a larger diameter than the at least one front wheel.

In some embodiments, the wheeled base may have at least one front wheel and at least two rear wheels and the rear wheels may have a smaller diameter than the at least one front wheel.

In some embodiments, the at least one front wheel may be steerable.

In some embodiments, the wheeled base may have rear wheels that are positioned outwardly of an area occupied by the cleaning unit when the cleaning unit is mounted on the wheeled base. Alternately, or in addition, the wheeled base may have front wheels that are positioned outwardly of an area occupied by the cleaning unit when the cleaning unit is



mounted on the wheeled base. Such embodiments may be advantageous because the wheeled base may have a relatively wide stance, thereby providing greater stability to the surface cleaning apparatus. Additionally, the surface cleaning apparatus may be relatively close to the ground, and may therefore have a lower center of mass and increased stability.

In some embodiments, the cleaning unit may have a front end having a fluid inlet downstream from the dirty fluid inlet and the front end of the cleaning unit is positioned at a front end of the wheeled base.

In some embodiments, the cleaning unit may be lockably receivable on the wheeled base.

In some embodiments, the wheeled base may have at least one front wheel having a diameter of 1 to 3 inches and at least two rear wheels having a diameter of 1 to 3 inches.

In some embodiments, the cleaning unit may have a carry handle and/or a shoulder strap.

In some embodiments, the wheeled base may have at least one front wheel and at least two rear wheels, and the cleaning unit is receivable on an open platform.

In some embodiments, the wheeled base may have an absence of operating components.

It will be appreciated by a person skilled in the art that a surface cleaning apparatus may embody any one or more of the features contained herein and that the features may be used in any particular combination or sub-combination.

#### BRIEF DESCRIPTION OF THE DRAWINGS

The drawings included herewith are for illustrating various examples of articles, methods, and apparatuses of the teaching of the present specification and are not intended to limit the scope of what is taught in any way.

In the drawings:

FIG. 1 is a perspective view of an embodiment of a surface cleaning apparatus of the present invention;

FIG. 2 is a front view of the embodiment of FIG. 1;

FIG. 3 is a side view of the embodiment of FIG. 1;

FIG. 4 is a top view of the embodiment of FIG. 1;

FIG. 5 is a perspective view of the embodiment of FIG. 1, showing a surface cleaning unit removed from a wheeled base;

FIG. 6 is a side view of the embodiment of FIG. 1, showing a surface cleaning unit removed from a wheeled base;

FIGS. 7-9 are cross-sections taken along line 7-7 in FIG. 1, showing alternate configurations of a cleaning unit;

FIG. 10 is a perspective illustration of an alternate embodiment of a surface cleaning apparatus of the present invention, showing a lid in an open position;

FIG. 11 is a perspective view of another embodiment of a surface cleaning apparatus;

FIG. 12 is another perspective view of the surface cleaning apparatus of FIG. 11;

FIG. 13 is a perspective view of the surface cleaning apparatus of FIG. 11 with a surface cleaning unit detached;

FIG. 14 is another perspective view of the surface cleaning apparatus of FIG. 11 with a surface cleaning unit detached;

FIG. 15 is a schematic representation of another embodiment of a surface cleaning apparatus;

FIG. 16 is a schematic representation of the surface cleaning apparatus of FIG. 15 with a surface cleaning unit detached;

FIG. 17 is a schematic representation of another embodiment of a surface cleaning apparatus;

FIG. 18 is a perspective view of another embodiment of a surface cleaning apparatus;

FIG. 19 is another perspective view of the surface cleaning apparatus of FIG. 18 with a cyclone bin assembly removed;

FIG. 20 is a perspective view of the surface cleaning apparatus of FIG. 18 with a surface cleaning unit detached and a cyclone bin assembly removed from the surface cleaning unit; and,

FIG. 21 is a bottom perspective view of the cyclone bin assembly of the surface cleaning apparatus of FIG. 18 in the open position.

#### DESCRIPTION OF VARIOUS EMBODIMENTS

Various apparatuses or processes will be described below to provide an example of an embodiment of each claimed invention. No embodiment described below limits any claimed invention and any claimed invention may cover processes or apparatuses that differ from those described below. The claimed inventions are not limited to apparatuses or processes having all of the features of any one apparatus or process described below or to features common to multiple or all of the apparatuses described below. It is possible that an apparatus or process described below is not an embodiment of any claimed invention. Any invention disclosed in an apparatus or process described below that is not claimed in this document may be the subject matter of another protective instrument, for example, a continuing patent application, and the applicants, inventors or owners do not intend to abandon, disclaim or dedicate to the public any such invention by its disclosure in this document.

#### Portable Cleaning Unit Construction

The following is a description of portable cleaning unit constructions that may be used by itself in any surface cleaning apparatus or in any combination or sub-combination with any other feature or features disclosed herein.

Referring to FIGS. 1-4, an embodiment of a surface cleaning apparatus 10 of the present invention is shown. Surface cleaning apparatus 10 may be a canister type vacuum cleaner, a Shop-Vac™ type vacuum cleaner, or another type of vacuum cleaner that may be mounted to a wheeled base. Surface cleaning apparatus 10 comprises a dirty fluid inlet 12, a clean air outlet 14, and a fluid flow path extending therebetween. A portable cleaning unit 16 is provided in the fluid flow path. Cleaning unit 16 comprises at least one cyclonic separation stage 18 for removing dirt from air, or for removing liquid from air or to pick up liquid. Cleaning unit 16 further comprises a suction motor 20 for drawing fluid from the dirty fluid inlet 12 to the clean air outlet 14.

Dirty fluid inlet 12 is provided in a member 34. In the embodiment shown in FIGS. 1-6, member 34 is a hose. In the embodiment shown in FIGS. 7-10, member 34 is a nozzle. In other embodiment, member 34 may be, for example, a surface cleaning head. It will be appreciated that a flexible hose, a rigid wand or other attachment may be affixed or removably affixed to portable cleaning unit 16.

Referring to the exemplified embodiments of FIGS. 7-9, from dirty fluid inlet 12, fluid is directed to cleaning unit 16. Cleaning unit 16 may be of a variety of configurations. In the embodiment of FIGS. 7 and 8, cleaning unit 16 comprises a single cyclonic cleaning stage 18 preferably comprising a single cyclone housed in a first housing 44, and a filter assembly 38 and motor 20 housed in a second housing 46 adjacent the first housing. Accordingly, in this embodiment, the suction motor 20 is positioned laterally adjacent and

laterally spaced from the cyclonic cleaning stage **18**. In the embodiment of FIG. **9**, cleaning unit **16** comprises first **18** and second **48** cleaning stages housed in first housing **44**, and filter assembly **38** and motor **20** housed in second housing **46** laterally adjacent the first housing. In this embodiment, motor **20** is positioned laterally spaced from and laterally adjacent both of first **18** and second **48** cleaning stages. It will be appreciated that portable cleaning unit may utilize one or more cyclonic cleaning stages, each of which may comprise a single cyclone or a plurality of cyclones in parallel. In any embodiment, one or more additional cleaning stages may be used such as one or more filters.

For example, in the embodiments exemplified, cyclonic cleaning stage **18** includes a single cyclone chamber **22**. Cyclone chamber **22** comprises a dirty air inlet **24**, a separated or dirty material outlet **26**, and a clean air outlet **28**. A dirty or separated material collection chamber **30** is mounted below dirty material outlet **26**, for collecting material removed from the air in cyclone chamber **22**. In the embodiment shown, a divider plate **32** is associated with dirty material outlet **26**. Divider plate **32** is positioned below the dirty material outlet **26**, within the material collection chamber **30**. It will be appreciated that a divider plate may be used any one or more of the cyclones and it may be of any configuration and located at any position known in the art. Alternately, a divider plate may not be used and the cyclone chambers may be of any design.

Material collection chamber **30** may be of any configuration and may be emptied by a user in any manner known in the art. In the embodiment shown in FIGS. **7** and **8**, material collection chamber **30** has a bottom **31** that is openable by pivoting about a pivot pin **33**. In this embodiment, material collection chamber further comprises a latch **35**, for locking bottom **31** in place, and a button **37** for releasing the latch. In other embodiments, material collection chamber **30** may be emptied in another manner. For example, material collection chamber **30** may be movable or removable from surface cleaning apparatus **10**, such that it may be emptied, or may have another portion that opens. It may be removable from portable cleaning unit with the associated cyclone or cyclones as a sealed unit. See for example the embodiments of FIGS. **14** and **19**.

In some embodiments, a filter or a screen may be associated with clean air outlet **28**. For example, as shown in FIG. **8**, a cylindrical housing **53** may be mounted on clean air outlet **28** and may have a plurality of openings **55** which are provided with a screen (e.g. a wire mesh). Any such screen or filter known in the art may be used.

In the embodiment of FIGS. **7** and **8**, air is directed from cyclone chamber **22** out of clean air outlet **28**, and into an airflow passage **36**, which extends between first housing **44** and second housing **46**. From airflow passage **36**, air is directed through a filter assembly **38**, which, in the embodiments exemplified, comprises a pre-motor foam filter **40**, and a screen filter **42**. From filter assembly **38**, air is drawn past motor **20**, and out of clean air outlet **14**.

In the exemplified embodiment of FIG. **9**, from cyclone chamber **22**, air is directed out of clean air outlet **28** and into second cyclonic cleaning stage **48**. Second cyclonic cleaning stage **48** comprises a plurality of second stage cyclones **50** in parallel. Each second stage cyclone comprises an inlet (not shown) in fluid communication with clean air outlet **28**, and an outlet **52** in fluid communication with airflow passage **36**. Each second stage cyclone comprises a cyclonic cleaning region **54**, and a dirt collection region **56**. From outlets **28**, air is directed into airflow passage **36**, and into

filter assembly **38**. From filter assembly **38**, air is drawn past motor **20**, and out of clean air outlet **14**.

In other embodiments, cleaning unit **16** may be otherwise configured. For example, cleaning unit **16** may not comprise a filter assembly, or may comprise a plurality of filter assemblies. Additionally, cleaning unit **16** may comprise additional cleaning stages, which may be positioned laterally adjacent each other or above each other.

In the embodiments shown, the first **44** and second **46** housings are integrally molded. In other embodiments, the first **44** and second **46** housings may be separately manufactured and then secured together, such as by a common base or by gluing, welding or mechanically securing the two housings together. In some embodiments, first **44** and/or second **46** housing may be provided with an openable lid **45**, as shown in FIG. **10**. When a user opens lid **45**, the user may have access to components housed in first **44** and/or second housing **46**. For example, as shown in FIG. **10**, lid **45** may be provided with a plurality of flanges **47**, which are mounted on flanges **49** provided on housings **44** and/or **46**. Flanges **47** are pivotally connected together by pivot pins **51**. Accordingly, lid **45** may be pivoted from the closed position, as shown in FIGS. **1-9**, to the opened position, as shown in FIG. **10**.

Referring to FIG. **11**, another embodiment of a surface cleaning apparatus **110** is shown. Surface cleaning apparatus **110** is generally similar to surface cleaning apparatus **10**, and analogous features are identified using like reference characters indexed by **100**.

Surface cleaning apparatus **110** comprises a dirty fluid inlet **112**, a clean air outlet **114**, and a fluid flow path extending therebetween. A portable cleaning unit **116** is provided in the fluid flow path. Cleaning unit **116** comprises at least one cyclonic separation stage **118** for removing dirt from air, or for removing liquid from air or to pick up liquid. Cleaning unit **116** further comprises a suction motor **120** for drawing fluid from the dirty fluid inlet **112** to the clean air outlet **114**. Dirty fluid inlet **112** is provided in a member **134**, which in this embodiment is a surface cleaning head.

In this embodiment the cleaning unit **116** is mounted to a wheeled base **158**. Wheeled base **158** comprises a plurality of wheels **160**, and a cradle **162**, which receives cleaning unit **116**. The portable cleaning unit **116** can be operated while seated in the cradle **162** (FIGS. **11** and **12**) and can be lifted out of the cradle **162** and used as a hand carryable apparatus (FIG. **13**).

Referring to FIG. **14**, in this embodiment the cyclone cleaning stage **118** includes a cyclone chamber **122**. Cyclone chamber **122** comprises a dirty air inlet **124**, a separated or dirty material outlet **126**, and a clean air outlet **128** (FIG. **14**). A dirty or separated material collection chamber **130** is beside the cyclone chamber **122** and in communication with the dirty material outlet **126**, for collecting material removed from the air in cyclone chamber **122**.

Material collection chamber **130** may be of any configuration and may be emptied by a user in any manner known in the art. In the embodiment shown in FIG. **14**, material collection chamber **130** has a bottom **131** that is openable by pivoting about a pivot pin **133**. In this embodiment, material collection chamber further comprises a latch **135**, for locking bottom **131** in place, and a button **137** for releasing the latch. In this embodiment the material collection chamber **130** may be movable or removable from surface cleaning apparatus **110** and from the portable cleaning unit **116**, such that it may be emptied, and is removable from portable cleaning unit **116** with the associated cyclone **118** or cyclones as a sealed unit.

Referring to FIGS. 18-21, another embodiment of a surface cleaning apparatus 510 is shown. Apparatus 510 is generally similar to surface cleaning apparatus 10, and analogous features are identified using like reference characters indexed by 500.

Referring to FIG. 18, surface cleaning apparatus 510 comprises a dirty fluid inlet 512, a clean air outlet 514, and a fluid flow path extending therebetween. A portable cleaning unit 516 is provided in the fluid flow path. Cleaning unit 516 comprises at least one cyclonic separation stage 518 (FIG. 21) for removing dirt from air, or for removing liquid from air or to pick up liquid. Cleaning unit 516 further comprises a suction motor 520 (FIG. 20) for drawing fluid from the dirty fluid inlet 512 to the clean air outlet 514. Dirty fluid inlet 512 is provided in a member 534, which in this embodiment is a surface cleaning head.

In this embodiment the cleaning unit 516 is mounted to a wheeled base 558. Wheeled base 558 comprises a plurality of wheels 560, and a cradle 562 (FIG. 20), which receives cleaning unit 516. The portable cleaning unit 516 can be operated while seated in the cradle 562 (FIG. 18) and can be lifted out of the cradle 562 and used as a hand carryable apparatus (FIG. 20).

Referring to FIG. 21, in this embodiment the cyclone cleaning stage 518 includes a cyclone chamber 522. Cyclone chamber 522 comprises a dirty air inlet 524 (FIG. 19), a separated or dirty material outlet 526, and a clean air outlet 528. A dirty or separated material collection chamber 530 is beside the cyclone chamber 522 and in communication with the dirty material outlet 526, for collecting material removed from the air in cyclone chamber 522.

Material collection chamber 530 may be of any configuration and may be emptied by a user in any manner known in the art. In the embodiment shown in FIG. 21, material collection chamber 530 has a bottom 531 that is openable by pivoting about a pivot pin 533. In this embodiment, material collection chamber further comprises a latch 535, for locking bottom 531 in place, and a button 537 for releasing the latch.

#### Wheeled Base Construction

The following is a description of a wheeled base construction that may be used by itself in any surface cleaning apparatus or in any combination or sub-combination with any other feature or features disclosed herein.

Referring again to FIGS. 1-4, portable cleaning unit 16 is mounted to a wheeled base 58. Wheeled base 58 comprises a plurality of wheels 60, and a cradle 62, which receives cleaning unit 16.

In some embodiments, cleaning unit 16 may be permanently mounted to wheeled base 58, for example via one or more bolts. In other embodiments, cleaning unit 16 may be removably mounted to wheeled base 58. For example, a user may remove cleaning unit 16 from wheeled base in order to maneuver cleaning unit 16, or to empty material collection chamber 30. In such embodiments, cleaning unit 16 is portable. For example, as shown in FIGS. 5 and 6, cleaning unit 16 may be removed from wheeled base 58 by lifting cleaning unit 16 off of wheeled base 58.

In any embodiment, surface cleaning apparatus 10 may comprise a handle 64, and/or a shoulder strap 65 (shown in FIG. 8) for maneuvering cleaning unit 16 when it is removed from wheeled base 58. In some embodiments, handle 64 may be integrally formed with one or both of first 44 and second 46 housings.

Surface cleaning apparatus 10 may further comprise a locking member (not shown), such that cleaning unit 16 may be lockably received on wheeled base 58. The locking

member may comprise any suitable locking member known in the art, such as, for example, a quick release latch, a friction or snap fit, a set screw, a tie down strap (e.g., a strap which may be wrapped around cleaning unit 16) or the like.

The lock may be actuatable by a foot pedal. Alternately wheeled base 58 may have side wall extending up around cradle 62 within which portable cleaning unit 16 is received. It will be appreciated that cradle 64 may be any member on which portable cleaning unit 16 may be received or secured, such as a flat base with or without side walls.

In the embodiments exemplified, wheeled base 58 comprises a front wheel 66, and two rear wheels 68a, 68b. Accordingly, cradle 62 is a platform that is generally polygonal and, preferably, generally triangular in configuration. This configuration may provide increased maneuverability to surface cleaning apparatus 10. In other embodiments, wheeled base 58 may comprise another number of wheels. For example, in some embodiments, wheeled base 58 may comprise two front wheels and two rear wheels. It will be appreciated that, as exemplified, housings 44, 46 may be oriented on cradle 62 with the suction motor at the rearward end of portable cleaning unit 16 and the inlet to portable cleaning unit 16 at the forward end of the front housing. In alternate configurations, housings 44, 46 may be positioned side by side. Further, if more than two housings 44, 46 are provided, then the housings may be arranged linearly, in a triangular configuration or any other desired configuration.

In some embodiments, front wheel 66 is rotatably mounted about a vertical axis to cradle 62 (e.g., is a caster wheel), and rear wheels are non-rotatably mounted about a vertical axis. Accordingly, front wheel 66 may be steerable. In other embodiments, all of front wheel 66 and rear wheels 68 may be caster wheels, or may be non-rotatably mounted wheels.

In some embodiments, wheeled base 58 has a length greater than its width. That is, the distance L between front wheel 66 and axis 67 extending between rear wheels 68a, 68b, is greater than the distance W between rear wheels 68a, 68b, along axis 67. In other embodiments, wheeled base 58 may have a width W greater than its length L, or may have width W equal to its length L.

In the embodiments shown, front wheel 66 is of a smaller diameter than rear wheels 68a, 68b. Alternately, rear wheels 68a, 68b may be smaller than front wheel 66. Preferably, both the front and rear wheels are each relatively large. For example, in some embodiments, front wheel(s) may have a diameter of between about 0.5-4 inches, preferably 1-3 inches and more preferably 1.5-2.5 inches. In some embodiments, rear wheels may have a diameter of between about 0.5-4 inches, preferably 1-3 inches and more preferably 1.5-2.5 inches. In one particular embodiment, both front wheel(s) 66 and rear wheels 68a, 68b have a diameter in the same range. Such embodiments may be advantageous to provide surface cleaning apparatus 10 with increased maneuverability and with increased stability.

In the embodiments shown, wheeled base 58 is configured such that, when cleaning unit 16 is mounted on cradle 62, rear wheels 58 are positioned outwardly of cleaning unit 16. That is, rear wheels 58 are separated by a distance W that is greater than the width W' of cleaning unit 16. Such embodiments may provide surface cleaning apparatus 10 with a wider stance, and accordingly with increased stability. Additionally, because rear wheels 68 are positioned outwardly of cleaning unit 16, rear wheels 68 may be provided with an increased diameter, as previously mentioned, without increasing the distance between cleaning unit 16 and a surface such as a floor. Accordingly, the center of mass of

cleaning unit 16 may remain low, which further increases the stability of surface cleaning apparatus 10.

In some embodiments, wheeled base 58 may comprise operating components of surface cleaning apparatus 10, such as a suction motor (see FIG. 17). For example, wheeled base may comprise a portion that is provided in the fluid flow path, and includes a filter assembly (not shown). In other embodiments, as exemplified, wheeled base 58 may not comprise any operating components (i.e. wheeled base has an absence of operating components).

In the embodiments shown, cleaning unit 16 is oriented such that dirty fluid inlet 12 is provided at a front end 70 of surface cleaning apparatus 10, adjacent front wheel 66, and suction motor 20 is provided at a rear end 72 of surface cleaning apparatus 10, adjacent rear wheels 68. In other embodiments, cleaning unit 16 may be otherwise oriented. For example, suction motor 20 may be provided at front end 70, and dirty fluid inlet 12 may be provided at rear end 72. Alternatively, cleaning unit 16 may be oriented such that suction motor 20 and dirty fluid inlet 12 are equally spaced from front wheel 66 and rear wheels 68. That is, cleaning unit 16 may be positioned substantially sideways in wheeled base 58.

In some embodiments, portable cleaning unit 16 may be connected to a remote surface cleaning head by connected in air flow communication with the wheeled base, wherein the remote surface cleaning head may be connected or removably connected in air flow communication with the wheeled base. Accordingly, when portable cleaning unit 16 is placed on the wheeled base, it may be automatically connected in air flow communication with the wheeled base (see for example FIGS. 15, 17 and 19) or the user may have to connect portable cleaning unit 16 in air flow communication with the wheeled base, such as by connecting a hose of portable cleaning unit 16 in air flow communication with an air outlet of the wheeled base (see for example FIGS. 5 and 6).

As exemplified in FIGS. 5 and 6, wheeled base 62 may comprise a floor cleaning mount 82 coupled to cradle 62. A first end 84 of mount 82 is configured for receiving member 34, which, in the embodiments exemplified in FIGS. 1-6, is a hose. A second end 86 of mount 82 is configured for receiving another member, for example a remote surface cleaning head that is preferably at the distal end of a wand and a flexible hose extends between the wand and mount 82 (not shown). It will be appreciated that portable cleaning unit 16 may be designed such that the inlet of the portable cleaning unit automatically is connected in flow communication with mount 82 when portable cleaning unit 16 is positioned on wheeled base 58, such as by use of an inlet port aligned with first end 84 or a rigid pipe that is fittable thereon. Alternately, as exemplified, a flexible hose 34 that is manually insertable may be used. An advantage of this design is that the attachment member for a wand or the like is provided on the platform and not the portable cleaning unit. Therefore, the wand may be used to pull wheeled base 58 without risk of pulling portable cleaning unit 16 off of wheeled base 58. Further, preferably the attachment point is close to the floor, preferably at the level of cradle 62, thereby lowering the point at which wheeled base 58 may be pulled and increasing the stability of wheeled base 58 when it is being pulled.

It will be appreciated that in the portable mode, a wand or flexible hose and wand, or other member known in the art may be attached to hose 34 or hose 34 may be removed and the wand or flexible hose and wand, or other member known in the art may be attached directly to the inlet to housing 44.

In some embodiments, one or more accessories, such as cleaning brush 74 and wand extension 76 may be secured to the upper surface of lid 45, such as by means of mounts 78. Accordingly, extension 76 may be configured to function as a handle (e.g. central section 76 may be arcuate in shape or be spaced from lid 45), to define an opening 80 between the upper surface of lid 34 such that extension 76 of brush 74 may be a carry handle 64 for the vacuum cleaner. Alternatively, extension 76 may be configured to seat on handle 64 and permit handle 64 to be used when brush 74 is mounted on portable cleaning unit 16. In other embodiments, one or more accessories may be provided in a recess in the lower surface of portable cleaning unit 16 or in an upper surface of wheeled base 58.

#### 15 Removable Dirt Chamber

The following is a description of a portable cleaning unit having a removable dirt chamber that may be used by itself in any surface cleaning apparatus or in any combination or sub-combination with any other feature or features disclosed herein.

As exemplified in FIG. 14, the cyclone chamber 118 and material collection chamber 130 may be constructed as a one piece assembly and are referred to collectively as a cyclone bin assembly 188. In accordance with this aspect, cyclone bin assembly 188 may be removed from the portable surface cleaning unit 116 when the portable surface cleaning unit 116 is seated on the base 158 (FIGS. 14 and 19) and when the portable surface cleaning unit 116 is separated from the base 158 (FIG. 13). This may allow a user to remove only the cyclone bin assembly 188, for example for emptying, regardless of whether the surface cleaning unit 116 is docked on the base 158.

As exemplified in FIGS. 18-21, the material collection chamber 530 may be movable or removable from surface cleaning apparatus 510 and from the portable cleaning unit 516, such that it may be emptied, and is removable from portable cleaning unit 516 with the associated cyclone 518 or cyclones as a sealed unit.

In the illustrated embodiment, the cyclone chamber 518 and material collection chamber 530, referred to collectively as a cyclone bin assembly 588, can be removed from the portable surface cleaning unit 516 when the portable surface cleaning unit 516 is seated on the base 558 (FIG. 19) and when the portable surface cleaning unit 516 is separated from the base 558 (FIG. 20). This may allow a user to remove only the cyclone bin assembly 588, for example for emptying, regardless of whether the surface cleaning unit 516 is docked on the base 558.

Referring to FIG. 18, in the illustrated embodiment, when the surface cleaning unit 516 is mounted on the base 558 the air flow path between the surface cleaning head 534 and the suction motor in the surface cleaning unit 516 includes a rigid conduit 589, a flexible hose 590a.

In this embodiment, the first hose 190a is connected to the surface cleaning unit 516 and extends between a downstream end 592a (with reference to the direction of airflow through the hose 590a) that is connected to the surface cleaning unit 516 and the rigid conduit 589. In this configuration, when the surface cleaning unit 516 is removed from the base 558 the hose 590a comes with the surface cleaning unit 516 (FIG. 20).

It will be appreciated that, in alternate embodiments, material collection chamber 130 may be a separate unit and may be removable without the cyclone chamber. Alternately, or in addition, material collection chamber 130 may be removed with the handle of the portable cleaning unit. An advantage of this design is that the handle of the portable

15

cleaning unit may be useable to manipulate the material collection chamber 130 or cyclone bin assembly when removed for emptying.

#### Automatic Portable Cleaning Unit Hose Connection

The following is a description of automatically connect- 5 ing a hose of the portable cleaning unit in air flow communication with the base when the portable cleaning unit is placed on the base that may be used by itself in any surface cleaning apparatus or in any combination or sub-combination with any other feature or features disclosed herein.

Referring to FIG. 12, in the illustrated embodiment, when the surface cleaning unit 116 is mounted on the base 158, the air flow path between the remote surface cleaning head 134 and the suction motor in the surface cleaning unit 116 includes a rigid conduit or wand 189, a first flexible hose 190a and a second flexible hose 190b (see also FIG. 14) 10 positioned downstream from the first hose 190a.

The first hose 190a extends from its upstream that is connected to rigid conduit 189 to its downstream end 192a (with reference to the direction of airflow through the hose 190a) that is connected to the base 158. The first hose 190a has a diameter 191a. While the first hose 190a may be removably connectable to the base 158, first hose 109a remains attached to the base 158 regardless of the position of the surface cleaning unit 116 (FIGS. 12 and 14).

Referring to FIG. 13, the second hose 190b is attached to and is removable with the surface cleaning unit 116. A downstream end 192b of the hose 190b is attached to the air inlet 124 of the cyclone chamber 118 and the upstream end 193b is removably connectable in air flow communication with the air outlet of the base 158 (e.g., opening 195 of coupling 194). When the surface cleaning unit 116 is removed from the base 158, the upstream or inlet end 193b of the hose 190b can be used as a second or auxiliary dirty air inlet for drawing fluid and debris into the air flow path. 15 Optionally, auxiliary cleaning tools may be attached to the inlet end 193b of the hose 190b. In this configuration, the first hose 190a does not form part of the airflow path to the surface cleaning unit 116.

The second hose 190b is shown in a wrapped or storage position in FIG. 13 in which it is wrapped around part of the surface cleaning unit 116. When the surface cleaning unit 116 is in use as a portable cleaning unit the second hose 190b can be unwound and extended. Preferably, the second hose 190b is extensible to increase its cleaning range. The second hose 190b has a diameter 191b, which optionally may be smaller than diameter 191a. This may help reduce the overall size of the surface cleaning unit 116 and may help it nest on the base 158. However, it is preferred that they have the same or similar diameters so as to provide an air flow path that has a generally constant diameter. The hoses 190a and 190b may be generally similar. Alternatively, they may have different properties. For example, the first hose 190a may be non-extensible and relatively stiff (to allow a user to pull the hose 190a to advance the base 158 across the surface) and the second hose 190b may be extensible and less stiff.

Referring to FIG. 12, when the surface cleaning unit 116 is seated on the base 158, the inlet end 193b of the second hose 190b is connected in air flow communication with the downstream end 192a of the first hose 190a, using coupling 194, thereby re-establishing air flow communication between the cleaning head 134 and the surface cleaning unit 116.

Referring to FIG. 13, the coupling 194 may be any suitable connector, and in the example illustrated, is an elbow-type connector with a downstream opening 195 sur-

16

rounded by a sealing face 196. The surface cleaning unit 116 may be configured such that the upstream end 193b of the second hose 190b is aligned with the opening 195 and seals against seal face 196 to establish the air flow path when the surface cleaning unit 116 is placed on base 158. Accordingly, sealing face 196 is sealed by the inlet end 193b automatically when the surface cleaning unit 116 is inserted vertically onto the base 158.

In order to provide a seal, one or both of base 158 and surface cleaning unit 116 may be configured to provide sufficient abutment therebetween so that an air tight seal is created. As exemplified in FIG. 13, the rear face of coupling 194 is angled and a mating angled surface may be provided on portable cleaning unit 116. Accordingly, when portable cleaning unit is placed on base 158, portable cleaning unit is urged rearwardly and the rear end of portable cleaning unit 116 may abut the rear wall of base 158 thereby pressing the upstream end 193b of the second hose 190b against the opening 195 and optionally compressing a gasket or the like to create an air tight seal.

If the cyclone bin assembly is removable, then the remaining body of portable cleaning unit 116 may also or alternately be angled to press the cyclone inlet 524 against opening 195 (see for example FIG. 19).

#### Valve to Switch Between Hoses

The following is a description of alternate air flow paths that may be used by itself in any surface cleaning apparatus or in any combination or sub-combination with any other feature or features disclosed herein.

In accordance with this aspect, the portable cleaning unit may incorporate a hose which is different to first hose 190a. For example, it may have a smaller diameter. Accordingly, it may be preferred not to use such a hose in the air flow path when portable cleaning unit 116 is mounted on the base since the smaller diameter hose would reduce air flow and increase the back pressure. However, the smaller diameter hose may be lighter and easier to use in a portable mode (i.e., when surface cleaning unit 116 is removed from base 158). In such a case, a valve may be provided to selective connect the cyclone air inlet with the different hoses or air flow paths. The valve may be manually operable or automatically operable. For example, the valve may be actuated automatically when the surface cleaning unit 116 is removed from the base or when the smaller diameter hose is deployed from a storage position for use.

Accordingly, if second hose 190b has a smaller diameter into the air flow path when the surface cleaning unit 116 is docked, a user may optionally detach the downstream end 192b of the second hose 190a from the air inlet 124 (thereby removing the second hose 190b from the air flow circuit) and can reposition the downstream end 192a of the hose 190a to be connected directly to the inlet 124. Alternately, inlet 124 could be automatically connected in air flow communication with opening 195 when surface cleaning unit 116 is placed on base 158.

Optionally, instead requiring a user to reconfigure a hose, the surface cleaning apparatus may include a valve positioned in the air flow path that allows the air flow to be switched between the first and second hoses. In this configuration, both hoses can remain attached to their respective components, and the air flow path to the surface cleaning unit 116 can include either of the first and second hoses. Optionally, one of the hoses may be detachable and connectable to the other of the hoses, such that one large hose is created and forms the air flow path to the surface cleaning unit.

17

Referring to FIGS. 15 and 16, a schematic representation of another embodiment of a surface cleaning apparatus 210 is illustrated. Surface cleaning apparatus 210 is generally similar to apparatus 10, and analogous features are identified using like reference characters indexed by 200.

In this embodiment, the surface cleaning unit 216 includes a valve 297 provided in the air flow path, upstream from the air inlet of the cyclone chamber 218. The valve is connected to the downstream end 292b of the second hose 290b, and the valve 297 and second hose 290b are removable with the surface cleaning unit 216 (FIG. 16). When the surface cleaning unit 216 is seated on base 258, the valve can connect to coupling 294 automatically or manually. An actuating lever 298 allows a user to change to position of the valve 297 so that, when the surface cleaning unit 216 is docked, the first hose 290a is connected in air flow communication with the surface cleaning unit 216 and the second hose 290b is sealed (but remains attached and does not require re-configuration). Optionally, the valve 297 can be automatically actuated when the surface cleaning unit 216 is placed on or removed from the base 258 to adjust the air flow path accordingly.

#### Use of Dual Suction Motors

The following is a description of the use of dual suction motors that may be used by itself in any surface cleaning apparatus or in any combination or sub-combination with any other feature or features disclosed herein.

Optionally, the base of the surface cleaning apparatus may include some operating components of the surface cleaning apparatus, including, for example a suction motor, the power cord and a cord reel. Providing components in the base may help reduce the weight and/or overall size of the portable surface cleaning unit.

Referring to FIG. 17, a schematic representation of another embodiment of a surface cleaning apparatus 310 is shown. The surface cleaning apparatus 310 is generally similar to surface cleaning apparatus 10, and analogous features are identified using like reference characters indexed by 300.

In the illustrated embodiment, the surface cleaning apparatus 310 includes a base 358 and a surface cleaning unit 316 that can be mounted on the base 358 (as illustrated), and can be detached to be used separately from the base 358.

The surface cleaning unit 316 includes a cyclone bin assembly 388 that has a cyclone chamber 318 and a dirt collection chamber 330. The cyclone chamber 318 has an air inlet 324 and an air outlet 328. A dirt outlet in the form of a slot 326 provides communication between the cyclone chamber 318 and the dirt collection chamber 330.

A first suction motor 320a is provided in the surface cleaning unit 316. An air flow conduit 400 provides an air flow path between the air outlet of the pre-motor filter housing and the suction motor 320a. Accordingly, a pre-motor filter 338 is provided in the air flow path between the air outlet 328 of the cyclone chamber 318 and the motor 320a.

In the illustrated embodiment the electrical cord 401 is wound around a cord reel 402 that is provided in the base 358. In addition, a second suction motor 320b is provided in the base 358 and is in electrical communication with the power cord 401 such that the second suction motor 358 can be powered by an external power supply (e.g. a wall socket). A base conduit 403 provides air flow communication between the second suction motor 320b and a port 404 on the upper surface of the base 358.

When the surface cleaning unit 316 is mounted on the base 358, a mating port 406 on the surface cleaning unit 316

18

may connect to and seal the port 404. Preferably, a valve 407 (e.g. any suitable valve such as a two position valve and a ball valve) is provided, e.g., in the air flow path between the filter 338 and the motor 320a. The valve 407 is also in air flow communication with the port 406, and is operable to selectively connect either port 406 or conduit 400 in airflow communication with the cyclone bin assembly 388. When conduit 400 is connected, suction motor 320a may be used to draw air through the surface cleaning unit 316 (and preferably motor 320b is not). When port 406 is connected, suction motor 320b may be used to draw air through the surface cleaning unit 316 (and preferably motor 320a is not). Preferably, the valve 407 is configured (for example via a biasing member or linkage member) so that when the surface cleaning unit 316 is lifted off the base 358 the valve 407 automatically seals port 406 and connects conduit 400.

It will be appreciated that valve may be actuatable by other means, such as a member that is drivingly connected to the valve and the member is operable as the surface cleaning unit is placed and/or removed from base 358. It will be appreciated that motor 320b may be connected in air flow communication at an alternate location. For example, it could be downstream of motor 320a. Alternately, it could be a dirty air motor and located upstream of cyclone chamber 318.

Because the electrical cord 401 is provided in the base 358, when the surface cleaning unit 316 is detached from the base 358, it may no longer be connected to the external power source (e.g. wall socket). To provide power to the surface cleaning unit 316 when it is detached, the surface cleaning unit 316 includes an on-board energy storage member, e.g., one or more batteries 405. Alternatively, any other suitable energy storage member or power source can be used (fuel cell, combustion engine, solar cells, etc.). In the illustrated example, the batteries 405 provide DC power. In this configuration, when the surface cleaning unit 316 is detached from base 358, the suction motor 320a may operate using DC power, and may operate solely on the power supplied by batteries 405.

Optionally, when the surface cleaning unit 316 is re-attached to the base 358, power from the base 358 can be transferred to the surface cleaning unit 316, for example via detachable electrical connector 408. Preferably, if an electrical connector 408 is provided the power received from the base 358 can be used to charge the batteries 405 to help ensure the batteries 405 are charged when the surface cleaning unit 316 is removed.

Alternatively, there need not be an electrical connection between the base 358 and the surface cleaning unit 316. In such a configuration the batteries 405 may be charged via an alternate power source, or may be replaced with fresh batteries as needed. For example, the surface cleaning unit 116 may be provided with its own power cord, or the power cord 401 may be removable from base 358 and may be plugged into surface cleaning unit 116.

Optionally, the suction motor 320a may be smaller and/or less powerful than the suction motor 320b. Making the suction motor 320a smaller and lighter than suction motor 320b may help reduce the overall size and weight of the surface cleaning unit 316. For example, the suction motor 320b may be a 1000 watt motor, and the suction motor 320a may be a 600 watt motor. Reducing the power consumption of the suction motor 320a may also help prolong the amount of cleaning time that can be achieved using the batteries 405, before they need to be replaced and/or recharged.

In the illustrated embodiment, because suction motor 320b is in the base 358 with the electrical cord, it may be an

AC motor that can run on AC power received from a wall socket. Motor **320a** may be operated on DC power supplied by the batteries **405**.

In this configuration, a user may be able to select which suction motor **320a** or **320b** is to be used when the surface cleaning unit **316** is docked. For example, if performing a small job or if it is desirable to keep the noise level low a user may activate the smaller suction motor **320a**. Alternatively, if performing a large job a user may select to use the suction motor **320b** by activating the motor **320b** and positioning the valve **407** as appropriate.

Dual Operational Mode for a Portable Surface Cleaning Unit

The following is a description of the use of a dual operational mode for a portable surface cleaning unit that may be used by itself in any surface cleaning apparatus or in any combination or sub-combination with any other feature or features disclosed herein.

Alternately, or in addition to providing a motor **320b** in the base **358**, the suction motor **320a** in the surface cleaning unit may be operable on current supplied by an on board energy storage member (e.g., batteries **405**) when removed from base **358** and may be operable on current supplied from base **358** when mounted thereon.

Accordingly, when removed from the base **358**, motor **320a** may be operable on DC current supplied from batteries **405**. However, when mounted on the base **358** and electrical code **401** is plugged into an electrical outlet, current may be supplied from base **358** to motor **320a**. The current may be AC, in which case, motor **320a** may be operable on both AC and DC current (e.g., it has dual windings) or the AC current may be converted to DC current (such as by providing a power supply in one or both of the base **358** and the surface cleaning unit **116**).

Accordingly, for example, as shown in FIG. 17, an electrical connector **408** may be used to power the suction motor **320a** when the surface cleaning apparatus is docked on the base **358**. In this configuration the suction motor **320a** may be configured to also run on AC power or a power supply or converter module **409** may be provided to convert the incoming AC power to DC power. Optionally, the convertor module **409** may be in the base **358** so that the connector **408** is provided with DC power.

It will be appreciated that the suction motor of the portable cleaning unit may be operable on different power levels. It may be operable on a first or higher power level when mounted to the base and operable on power supplied from the base (which may be AC or DC). It may be operable on a lower power level when removed from the base.

It will be appreciated that certain features of the invention, which are, for clarity, described in the context of separate embodiments or separate aspects, may also be provided in combination in a single embodiment. Conversely, various features of the invention, which are, for brevity, described in the context of a single embodiment or aspect, may also be provided separately or in any suitable sub-combination.

What has been described above has been intended to be illustrative of the invention and non-limiting and it will be understood by persons skilled in the art that other variants and modifications may be made without departing from the scope of the invention as defined in the claims appended hereto. The scope of the claims should not be limited by the preferred embodiments and examples, but should be given the broadest interpretation consistent with the description as a whole.

What is claimed is:

1. A hand carryable surface cleaning apparatus comprising:

- (a) a dirt air inlet and a cleaned air outlet and a fluid flow path extending therebetween;
- (b) a first air treatment member;
- (c) a suction motor wherein the first air treatment member and the suction motor are part of the fluid flow path,
- (d) an air flow passage is provided from the first air treatment member to the suction motor, the air flow passage comprising a transverse portion and first and second opposed walls that extend in the direction of air flow through the passage; and,
- (e) an openable door comprising the first opposed wall is provided on an end of the hand carryable surface cleaning apparatus, whereby, when the door is opened, the first opposed wall is moved away from the second opposed wall such that the transverse portion of the airflow passage is opened.

2. The hand carryable surface cleaning apparatus of claim 1 wherein the suction motor has a suction motor axis that is oriented to be non-parallel to the axis of the air treatment member.

3. The hand carryable surface cleaning apparatus of claim 2 wherein the suction motor axis is orthogonal to the axis of the air treatment member.

4. The hand carryable surface cleaning apparatus of claim 1 further comprising a handle comprising a portion that extends upwardly.

5. The hand carryable surface cleaning apparatus of claim 4 wherein the handle has a lower end positioned adjacent the suction motor and an upper end positioned above the suction motor and forward of the lower end of the handle.

6. The hand carryable surface cleaning apparatus of claim 5 further comprising a second air treatment member that is positioned above and overlying the first air treatment member.

7. The hand carryable surface cleaning apparatus of claim 6 wherein the upper end of the handle is positioned above a pre-motor porous filter media.

8. The hand carryable surface cleaning apparatus of claim 1 wherein the first air treatment member comprises a cyclone.

9. The hand carryable surface cleaning apparatus of claim 1 further comprising a handle having a handle axis that extends in a handle axis plane, the suction motor has a suction motor axis that extends in a suction motor axis plane and the air treatment member axis extends in an air treatment member axis plane and the handle axis plane, the suction motor axis plane and the air treatment member axis plane are parallel.

10. The hand carryable surface cleaning apparatus of claim 9 wherein air treatment member comprises a cyclone and the air treatment member axis is a cyclone axis about which air rotates.

11. The hand carryable surface cleaning apparatus of claim 1 wherein the first air treatment member is nonremovably attached to the hand vacuum cleaner.

12. The hand carryable surface cleaning apparatus of claim 1 further comprising a second air treatment member that is positioned above and overlying the first air treatment member.

13. The hand carryable surface cleaning apparatus of claim 12 wherein the second air treatment member is removable when the openable door is opened.

14. The hand carryable surface cleaning apparatus of claim 12 wherein a pre-motor porous filter media is removable when the openable door is opened.

15. A hand carryable surface cleaning apparatus comprising:

21

- (a) a dirt air inlet and a cleaned air outlet and a fluid flow path extending therebetween;
- (b) a first air treatment member;
- (c) a suction motor wherein the first air treatment member and the suction motor are part of the fluid flow path,
- (d) an air flow passage is provided from the first air treatment member to the suction motor, the air flow passage having first and second opposed walls that extend in the direction of air flow through the passage; and,
- (e) a door closes an end of the hand carryable surface cleaning apparatus, whereby, when the door is opened, the first opposed wall is moved and the second opposed wall remains in position such that the airflow passage is opened.

16. The hand carryable surface cleaning apparatus of claim 15 wherein the suction motor has a suction motor axis that is oriented to be non-parallel to the axis of the air treatment member.

17. The hand carryable surface cleaning apparatus of claim 16 wherein the suction motor axis is orthogonal to the axis of the air treatment member.

18. The hand carryable surface cleaning apparatus of claim 15 further comprising a handle comprising a portion that extends upwardly.

19. The hand carryable surface cleaning apparatus of claim 18 wherein the handle has a lower end positioned adjacent the suction motor and an upper end positioned above the suction motor and forward of the lower end of the handle.

20. The hand carryable surface cleaning apparatus of claim 19 further comprising a second air treatment member that is positioned above and overlying the first air treatment member.

22

21. The hand carryable surface cleaning apparatus of claim 19 wherein the upper end of the handle is positioned above a pre-motor porous filter media.

22. The hand carryable surface cleaning apparatus of claim 15 wherein the first air treatment member comprises a cyclone.

23. The hand carryable surface cleaning apparatus of claim 15 further comprising a handle having a handle axis that extends in a handle axis plane, the suction motor has a suction motor axis that extends in a suction motor axis plane and the air treatment member axis extends in an air treatment member axis plane and the handle axis plane, the suction motor axis plane and the air treatment member axis plane are parallel.

24. The hand carryable surface cleaning apparatus of claim 23 wherein air treatment member comprises a cyclone and the air treatment member axis is a cyclone axis about which air rotates.

25. The hand carryable surface cleaning apparatus of claim 15 wherein the first air treatment member is non-removably attached to the hand vacuum cleaner.

26. The hand carryable surface cleaning apparatus of claim 15 further comprising a second air treatment member that is positioned above and overlying the first air treatment member.

27. The hand carryable surface cleaning apparatus of claim 26 wherein the second air treatment member is removable when the openable door is opened.

28. The hand carryable surface cleaning apparatus of claim 26 wherein a pre-motor porous filter media is removable when the openable door is opened.

\* \* \* \* \*