



US010080472B2

(12) **United States Patent**
Conrad

(10) **Patent No.:** **US 10,080,472 B2**
(45) **Date of Patent:** **Sep. 25, 2018**

(54) **HAND CARRIABLE SURFACE CLEANING APPARATUS**

(71) Applicant: **Omachron Intellectual Property Inc.**, Hampton (CA)

(72) Inventor: **Wayne Ernest Conrad**, Hampton (CA)

(73) Assignee: **Omachron Intellectual Property Inc.**, Hampton, Ontario (CA)

(*) Notice: Subject to any disclaimer, the term of this patent is extended or adjusted under 35 U.S.C. 154(b) by 0 days.

(21) Appl. No.: **15/051,272**

(22) Filed: **Feb. 23, 2016**

(65) **Prior Publication Data**

US 2016/0213211 A1 Jul. 28, 2016

Related U.S. Application Data

(63) Continuation of application No. 14/994,495, filed on Jan. 13, 2016, which is a continuation of application (Continued)

(51) **Int. Cl.**

A47L 5/24 (2006.01)
A47L 5/22 (2006.01)
A47L 9/12 (2006.01)
A47L 9/16 (2006.01)
A47L 9/22 (2006.01)

(52) **U.S. Cl.**

CPC *A47L 5/24* (2013.01); *A47L 5/225* (2013.01); *A47L 9/122* (2013.01); *A47L 9/16* (2013.01); *A47L 9/1608* (2013.01); *A47L 9/1683* (2013.01); *A47L 9/22* (2013.01)

(58) **Field of Classification Search**

CPC *A47L 5/24*; *A47L 9/1683*; *A47L 5/225*; *A47L 9/122*; *A47L 9/16*; *A47L 9/1608*; *A47L 9/22*

See application file for complete search history.

(56) **References Cited**

U.S. PATENT DOCUMENTS

911,258 A 2/1909 Neumann
1,600,762 A 9/1926 Hawley
(Continued)

FOREIGN PATENT DOCUMENTS

AU 112778 4/1940
CA 1077412 A1 5/1980
(Continued)

OTHER PUBLICATIONS

Extended European Search Report received on the corresponding European Patent Application No. 11157642.7-2316, dated May 8, 2012.

(Continued)

Primary Examiner — Christopher M Koehler

Assistant Examiner — Joel Crandall

(74) *Attorney, Agent, or Firm* — Philip C. Mendes da Costa; Bereskin & Parr LLP/S.E.N.C.R.L., s.r.l.

(57) **ABSTRACT**

A hand vacuum cleaner comprises an air flow passage extending from a dirty air inlet to a clean air outlet. A suction motor is positioned in the air flow path. At least one air treatment member, which is optionally a cyclone chamber, is positioned in the air flow path. A pre-motor filter is positioned in a pre-motor filter housing having an openable cover and the air treatment member air outlet axis extends through the pre-motor filter housing.

25 Claims, 20 Drawing Sheets

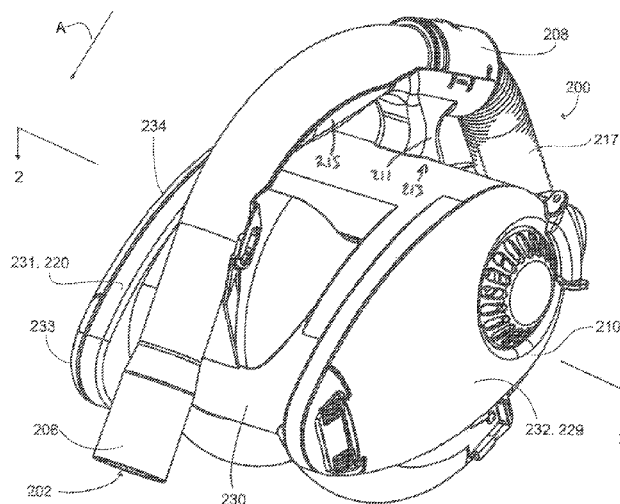

Related U.S. Application Data

No. 13/039,376, filed on Mar. 3, 2011, now Pat. No. 9,265,395, which is a continuation-in-part of application No. 12/722,705, filed on Mar. 12, 2010, now Pat. No. 8,578,555.

(56)

References Cited

U.S. PATENT DOCUMENTS

1,797,812 A 3/1931 Waring
 1,898,608 A 2/1933 Alexander
 1,937,765 A 12/1933 Leathers
 2,015,464 A 9/1935 Saint-Jacques
 2,152,114 A 3/1939 Van Tongeren
 2,542,634 A 2/1951 Davis et al.
 2,678,110 A 5/1954 Madsen
 2,731,102 A 1/1956 James
 2,811,219 A 10/1957 Wenzl
 2,846,024 A 8/1958 Bremi
 2,913,111 A 11/1959 Rogers
 2,917,131 A 12/1959 Evans
 2,937,713 A 5/1960 Stephenson et al.
 2,942,691 A 6/1960 Dillon
 2,942,692 A 6/1960 Benz
 2,946,451 A 7/1960 Culleton
 2,952,330 A 9/1960 Winslow
 2,981,369 A 4/1961 Yellott et al.
 3,002,215 A 10/1961 MacFarland
 3,032,954 A 5/1962 Racklyeft
 3,085,221 A 4/1963 Kelly
 3,130,157 A 4/1964 Kelsall et al.
 3,200,568 A 8/1965 McNeil
 3,204,772 A 9/1965 Ruxton
 3,217,469 A 11/1965 Eckert
 3,269,097 A 8/1966 German
 3,320,727 A 5/1967 Farley et al.
 3,372,532 A 3/1968 Campbell
 3,426,513 A 2/1969 Kurt
 3,498,068 A 3/1970 Tadayon
 3,518,815 A 7/1970 Peterson et al.
 3,530,649 A 9/1970 Porsch et al.
 3,561,824 A 2/1971 Homan
 3,582,616 A 6/1971 Wrob
 3,675,401 A 7/1972 Cordes
 3,684,093 A 8/1972 Kono
 3,822,533 A 7/1974 Oranje
 3,870,486 A * 3/1975 Eriksson A47L 7/0019
 55/309
 3,877,902 A * 4/1975 Eriksson A47L 5/365
 55/337
 3,933,450 A 1/1976 Percevault
 3,988,132 A 10/1976 Oranje
 3,988,133 A 10/1976 Schady
 4,097,381 A 6/1978 Ritzler
 4,187,088 A 2/1980 Hodgson
 4,218,805 A 8/1980 Brazier
 4,236,903 A 12/1980 Malmsten
 4,307,485 A 12/1981 Dessig
 4,373,228 A 2/1983 Dyson
 4,382,804 A 5/1983 Mellor
 4,409,008 A 10/1983 Solymes
 4,486,207 A 12/1984 Baillie
 4,678,588 A 7/1987 Shortt
 4,700,429 A 10/1987 Martin et al.
 4,744,958 A 5/1988 Pircon
 4,778,494 A 10/1988 Patterson
 4,826,515 A 5/1989 Dyson
 D303,173 S 8/1989 Miyamoto et al.
 4,853,008 A 8/1989 Dyson
 4,853,011 A 8/1989 Dyson
 4,853,111 A 8/1989 MacArthur et al.
 4,905,342 A 3/1990 Ataka
 4,944,780 A 7/1990 Usmani
 2,080,697 A 1/1992 Finke
 5,078,761 A 1/1992 Dyson
 5,090,976 A 2/1992 Dyson

5,129,125 A 7/1992 Gamou et al.
 5,224,238 A 7/1993 Bartlett
 5,230,722 A 7/1993 Yonkers
 5,254,019 A 10/1993 Noschese
 5,267,371 A 12/1993 Solerm et al.
 5,309,601 A 5/1994 Hampton et al.
 5,347,679 A 9/1994 Saunders et al.
 5,481,780 A 1/1996 Daneshvar
 5,599,365 A 2/1997 Alday et al.
 D380,033 S 6/1997 Masterton et al.
 5,755,096 A 5/1998 Holleyman
 5,815,878 A 10/1998 Murakami et al.
 5,858,038 A 1/1999 Dyson et al.
 5,858,043 A 1/1999 Geise
 5,893,938 A 4/1999 Dyson et al.
 5,935,279 A 8/1999 Kilstrom
 5,950,274 A 9/1999 Kilstrom
 6,071,095 A 6/2000 Verkaar
 6,071,321 A 6/2000 Trapp et al.
 6,080,022 A 6/2000 Shaberman et al.
 6,122,796 A 9/2000 Downham et al.
 6,221,134 B1 4/2001 Conrad et al.
 6,228,260 B1 5/2001 Conrad et al.
 6,231,645 B1 5/2001 Conrad et al.
 6,251,296 B1 6/2001 Conrad et al.
 6,260,234 B1 7/2001 Wright et al.
 6,341,404 B1 * 1/2002 Salo A47L 5/28
 15/350
 6,345,408 B1 2/2002 Nagai et al.
 6,406,505 B1 6/2002 Oh et al.
 6,434,785 B1 8/2002 Vandenbelt et al.
 6,440,197 B1 8/2002 Conrad et al.
 6,531,066 B1 3/2003 Saunders et al.
 6,553,612 B1 4/2003 Dyson et al.
 6,553,613 B2 4/2003 Onishi et al.
 6,560,818 B1 5/2003 Hasko
 6,581,239 B1 6/2003 Dyson et al.
 6,599,338 B2 7/2003 Oh et al.
 6,599,350 B1 7/2003 Rockwell et al.
 6,613,316 B2 9/2003 Sun et al.
 6,623,539 B2 9/2003 Lee et al.
 6,625,845 B2 9/2003 Matsumoto et al.
 6,648,934 B2 11/2003 Choi et al.
 6,712,868 B2 3/2004 Murphy et al.
 6,746,500 B1 6/2004 Park et al.
 6,782,583 B2 8/2004 Oh
 6,782,585 B1 8/2004 Conrad et al.
 6,818,036 B1 11/2004 Seaman
 6,833,015 B2 12/2004 Oh et al.
 6,868,578 B1 3/2005 Kasper
 6,874,197 B1 4/2005 Conrad
 6,896,719 B2 5/2005 Coates et al.
 6,929,516 B2 8/2005 Brochu et al.
 6,968,596 B2 11/2005 Oh et al.
 6,976,885 B2 12/2005 Lord
 7,160,346 B2 1/2007 Park
 7,162,770 B2 1/2007 Davidshofer
 7,175,682 B2 2/2007 Nakai et al.
 7,198,656 B2 4/2007 Takemoto et al.
 7,210,195 B2 5/2007 Howie et al.
 7,222,393 B2 5/2007 Kaffenberger et al.
 7,272,872 B2 9/2007 Choi
 7,278,181 B2 10/2007 Harris et al.
 7,341,611 B2 3/2008 Greene et al.
 7,354,468 B2 4/2008 Arnold et al.
 7,370,387 B2 5/2008 Walker et al.
 7,377,007 B2 5/2008 Best
 7,377,953 B2 5/2008 Oh
 7,386,915 B2 6/2008 Blocker et al.
 7,395,579 B2 7/2008 Oh
 7,448,363 B1 11/2008 Rasmussen et al.
 7,449,040 B2 11/2008 Conrad et al.
 7,488,363 B2 2/2009 Jeong et al.
 7,547,336 B2 * 6/2009 Fester A47L 9/122
 55/337
 7,547,337 B2 6/2009 Oh
 7,547,338 B2 6/2009 Kim et al.
 7,588,616 B2 9/2009 Conrad et al.
 7,597,730 B2 10/2009 Yoo et al.

(56)	References Cited	2006/0277712 A1*	12/2006	Kim	A47L 9/122 15/353
	U.S. PATENT DOCUMENTS	2006/0278081 A1	12/2006	Han et al.	
		2007/0067944 A1	3/2007	Kitamura	
		2007/0077810 A1	4/2007	Gogel	
7,601,188 B2	10/2009 Hwang et al.	2007/0079473 A1	4/2007	Min	
7,628,831 B2	12/2009 Gomiciaga-Pereda et al.	2007/0079585 A1	4/2007	Oh et al.	
7,779,506 B2	5/2010 Kang et al.	2007/0095028 A1	5/2007	Kim	
7,740,676 B2	6/2010 Burnham et al.	2007/0095029 A1	5/2007	Min	
7,770,256 B1	8/2010 Fester	2007/0209334 A1	9/2007	Conrad	
7,774,898 B2	8/2010 Hong et al.	2007/0209335 A1	9/2007	Conrad	
7,776,120 B2	8/2010 Conrad	2007/0271724 A1	11/2007	Hakan et al.	
7,803,207 B2	9/2010 Conrad	2007/0289089 A1	12/2007	Yacobi	
7,805,804 B2	10/2010 Loebig	2007/0289266 A1	12/2007	Oh	
7,811,349 B2	10/2010 Nguyen	2007/0289267 A1*	12/2007	Makarov	A47L 5/28 55/345
7,867,308 B2	1/2011 Conrad	2008/0040883 A1	2/2008	Beskow et al.	
7,922,794 B2	4/2011 Morphey	2008/0047091 A1	2/2008	Nguyen	
7,931,716 B2	4/2011 Dakham	2008/0134460 A1	6/2008	Conrad	
7,938,871 B2	5/2011 Lloyd	2008/0134462 A1	6/2008	Jansen et al.	
7,979,959 B2	7/2011 Courtney	2008/0172821 A1	7/2008	Kang et al.	
8,021,453 B2	9/2011 Howes	2008/0178416 A1	7/2008	Conrad	
8,062,398 B2	11/2011 Luo et al.	2008/0178418 A1	7/2008	Conrad	
8,117,712 B2	2/2012 Dyson et al.	2008/0178420 A1	7/2008	Conrad	
8,146,201 B2	4/2012 Conrad	2008/0190080 A1	8/2008	Oh et al.	
8,152,877 B2	4/2012 Greene	2008/0196194 A1	8/2008	Conrad	
8,156,609 B2	4/2012 Milne et al.	2008/0196745 A1	8/2008	Conrad	
8,161,599 B2	4/2012 Griffith et al.	2008/0216282 A1	9/2008	Conrad	
8,225,456 B2	7/2012 Hakan et al.	2008/0256744 A1	10/2008	Rowntreer et al.	
8,484,799 B2	7/2013 Conrad	2008/0263813 A1*	10/2008	Han	A47L 5/225 15/334
8,677,558 B2	3/2014 Conrad	2008/0301903 A1	12/2008	Cunningham et al.	
2001/0015132 A1	8/2001 Rohn et al.	2009/0056060 A1*	3/2009	Han	A47L 5/12 15/349
2002/0011050 A1	1/2002 Hansen et al.	2009/0100633 A1	4/2009	Bates et al.	
2002/0011053 A1	1/2002 Oh	2009/0113659 A1	5/2009	Jeon	
2002/0062531 A1	5/2002 Oh	2009/0144932 A1	6/2009	Yoo	
2002/0088208 A1	7/2002 Lukac et al.	2009/0165431 A1	7/2009	Oh	
2002/0112315 A1	8/2002 Conrad	2009/0205160 A1	8/2009	Conrad	
2002/0134059 A1	9/2002 Oh	2009/0205161 A1	8/2009	Conrad	
2002/0178535 A1	12/2002 Oh et al.	2009/0205298 A1	8/2009	Hyun et al.	
2002/0178698 A1	12/2002 Oh et al.	2009/0209666 A1	8/2009	Hellberg et al.	
2002/0178699 A1	12/2002 Oh	2009/0265877 A1	10/2009	Dyson et al.	
2003/0046910 A1	3/2003 Lee	2009/0282639 A1	11/2009	Dyson et al.	
2003/0066273 A1	4/2003 Choi et al.	2009/0300874 A1	12/2009	Tran et al.	
2003/0106180 A1	6/2003 Tsen	2009/0300875 A1	12/2009	Inge et al.	
2003/0159238 A1	8/2003 Oh	2009/0305862 A1	12/2009	Yoo	
2003/0159411 A1	8/2003 Hansen et al.	2009/0307564 A1	12/2009	Vedantham et al.	
2003/0200736 A1	10/2003 Ni	2009/0307863 A1	12/2009	Milne et al.	
2004/0010885 A1	1/2004 Hitzelberger et al.	2009/0307864 A1	12/2009	Dyson	
2004/0025285 A1	2/2004 McCormick et al.	2009/0308254 A1	12/2009	Dakham	
2004/0088816 A1	5/2004 Shimizu et al.	2009/0313958 A1	12/2009	Gomiciaga-Pereda et al.	
2004/0216263 A1	11/2004 Best et al.	2009/0313959 A1	12/2009	Gomiciaga-Pereda et al.	
2004/0216264 A1	11/2004 Shaver et al.	2010/0154150 A1	6/2010	McLeod	
2005/0081321 A1	4/2005 Milligan et al.	2010/0175217 A1	7/2010	Conrad	
2005/0115409 A1	6/2005 Conrad	2010/0212104 A1	8/2010	Conrad	
2005/0132528 A1	6/2005 Yau	2010/0224073 A1	9/2010	Oh et al.	
2005/0132529 A1	6/2005 Davidshofer	2010/0229321 A1	9/2010	Dyson et al.	
2005/0138763 A1	6/2005 Tanner et al.	2010/0229322 A1	9/2010	Conrad	
2005/0198769 A1	9/2005 Lee et al.	2010/0242210 A1	9/2010	Conrad	
2005/0198770 A1	9/2005 Jung et al.	2010/0243158 A1	9/2010	Conrad	
2005/0252179 A1	11/2005 Oh et al.	2010/0293745 A1	11/2010	Coburn	
2006/0016042 A1*	1/2006 Bruneau	2010/0299865 A1	12/2010	Conrad	
	A47L 9/122 15/314	2010/0299866 A1	12/2010	Conrad	
		2011/0146024 A1	6/2011	Conrad	
2006/0037172 A1	2/2006 Choi	2011/0168332 A1	7/2011	Bowe et al.	
2006/0042206 A1	3/2006 Arnold et al.	2011/0219570 A1	9/2011	Conrad	
2006/0090290 A1	5/2006 Lau	2012/0060322 A1	3/2012	Simonelli et al.	
2006/0123590 A1	6/2006 Fester et al.	2012/0216361 A1	8/2012	Millington et al.	
2006/0137304 A1	6/2006 Jeong et al.	2012/0222245 A1	9/2012	Conrad	
2006/0137306 A1	6/2006 Jeong et al.	2012/0222262 A1	9/2012	Conrad	
2006/0137309 A1	6/2006 Jeong et al.	2014/0237758 A1	8/2014	Conrad	
2006/0137314 A1	6/2006 Conrad et al.	2014/0237759 A1	8/2014	Conrad	
2006/0156508 A1	7/2006 Khalil	2014/0237768 A1	8/2014	Conrad	
2006/0162298 A1	7/2006 Oh et al.	2016/0367094 A1	12/2016	Conrad	
2006/0162299 A1	7/2006 North				
2006/0168922 A1	8/2006 Oh				
2006/0168923 A1	8/2006 Lee et al.				
2006/0207055 A1	9/2006 Ivarsson et al.				
2006/0207231 A1	9/2006 Arnold				
2006/0230715 A1	10/2006 Oh et al.				
2006/0230723 A1	10/2006 Kim et al.				
2006/0230724 A1	10/2006 Han et al.				
2006/0236663 A1	10/2006 Oh				

(56)

References Cited

U.S. PATENT DOCUMENTS

FOREIGN PATENT DOCUMENTS

CA 1218962 A 3/1987
 CA 2593950 C 6/2008
 CA 2438079 C 8/2009
 CA 2659212 A1 9/2010
 CN 1493244 A 5/2004
 CN 2657570 Y 11/2004
 CN 1887437 A 1/2007
 CN 1911151 B 4/2007
 CN 201223346 Y 4/2009
 CN 101455540 A 6/2009
 CN 101657133 A 2/2010
 CN 102188208 A 9/2011
 CN 103040412 A 4/2013
 CN 103040413 A 4/2013
 DE 875134 C 4/1953
 DE 9017798 U1 2/1992
 DE 9216071.9 U1 2/1993
 DE 4232382 C1 3/1994
 DE 112007003039 T5 10/2009
 DE 112007003052 T5 1/2010
 EP 493950 B1 7/1992
 EP 1031310 A2 8/2000
 EP 1200196 B1 6/2005
 EP 1535560 A2 6/2005
 EP 1674017 A2 6/2006
 EP 1779761 A2 5/2007
 EP 1676516 B1 1/2010
 EP 1629758 A3 10/2013
 FR 2812531 B1 11/2004
 GB 700791 A 12/1953
 GB 1029943 A 5/1966
 GB 1111074 A 4/1968
 GB 1386055 A 5/1975
 GB 2163703 B 1/1988
 GB 2268875 A 1/1994
 GB 2282979 B 10/1997
 GB 2365324 B 7/2002
 GB 2372431 A 8/2002
 GB 2441962 B 3/2011
 GB 2466290 B 10/2012
 JP 61131720 A 6/1986
 JP 2000140533 A 5/2000

JP 2003180579 A 7/2003
 JP 2010178773 A 8/2010
 JP 2010220632 A 10/2010
 JP 2011189132 A 9/2011
 JP 2011189133 A 9/2011
 WO 1980002561 A1 11/1980
 WO 9627446 A1 9/1996
 WO 9809121 A1 3/1998
 WO 9843721 A1 10/1998
 WO 01/07168 A1 2/2001
 WO 2004069021 A1 8/2004
 WO 2006026414 A3 8/2007
 WO 2008009883 A1 1/2008
 WO 2008009888 A1 1/2008
 WO 2008009890 A1 1/2008
 WO 2008009891 A1 1/2008
 WO 2008070962 A1 6/2008
 WO 2009/026709 A1 3/2009
 WO 2009026709 A1 3/2009
 WO 2010102396 A1 9/2010
 WO 2010142968 A1 12/2010
 WO 2010142969 A1 12/2010
 WO 2010142970 A1 12/2010
 WO 2010142971 A1 12/2010
 WO 2011054106 A1 5/2011
 WO 2012042240 A1 4/2012
 WO 2012117231 A1 9/2012

OTHER PUBLICATIONS

English machine translation of DE112007003052, as published on Jan. 14, 2010.
 English machine translation of DE112007003039, as published on Oct. 29, 2009.
 English machine translation of CN103040413, as published on Apr. 17, 2013.
 English machine translation of CN103040412, as published on Apr. 17, 2013.
 English machine translation of CN102188208, as published on Sep. 21, 2011.
 English machine translation of CN101657133, as published on Feb. 24, 2010.
 English machine translation of CN1911151, as published on Feb. 14, 2007.

* cited by examiner

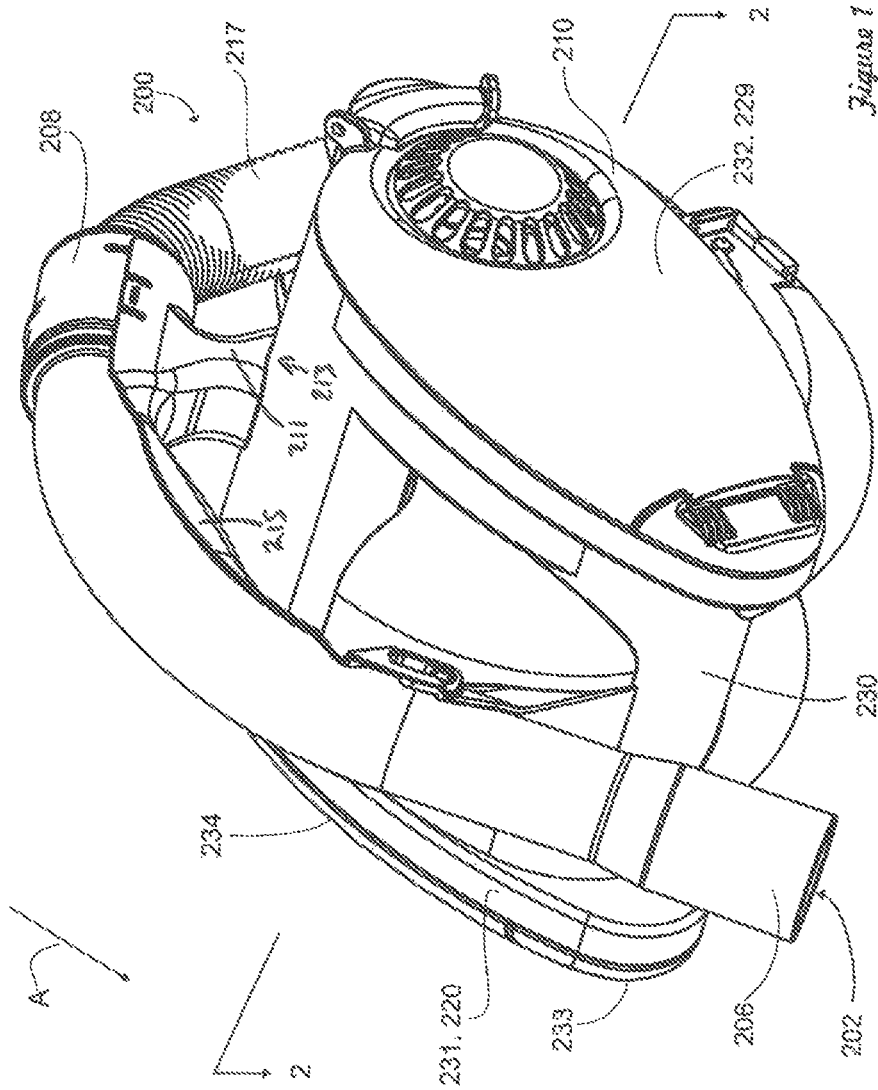

Figure 1

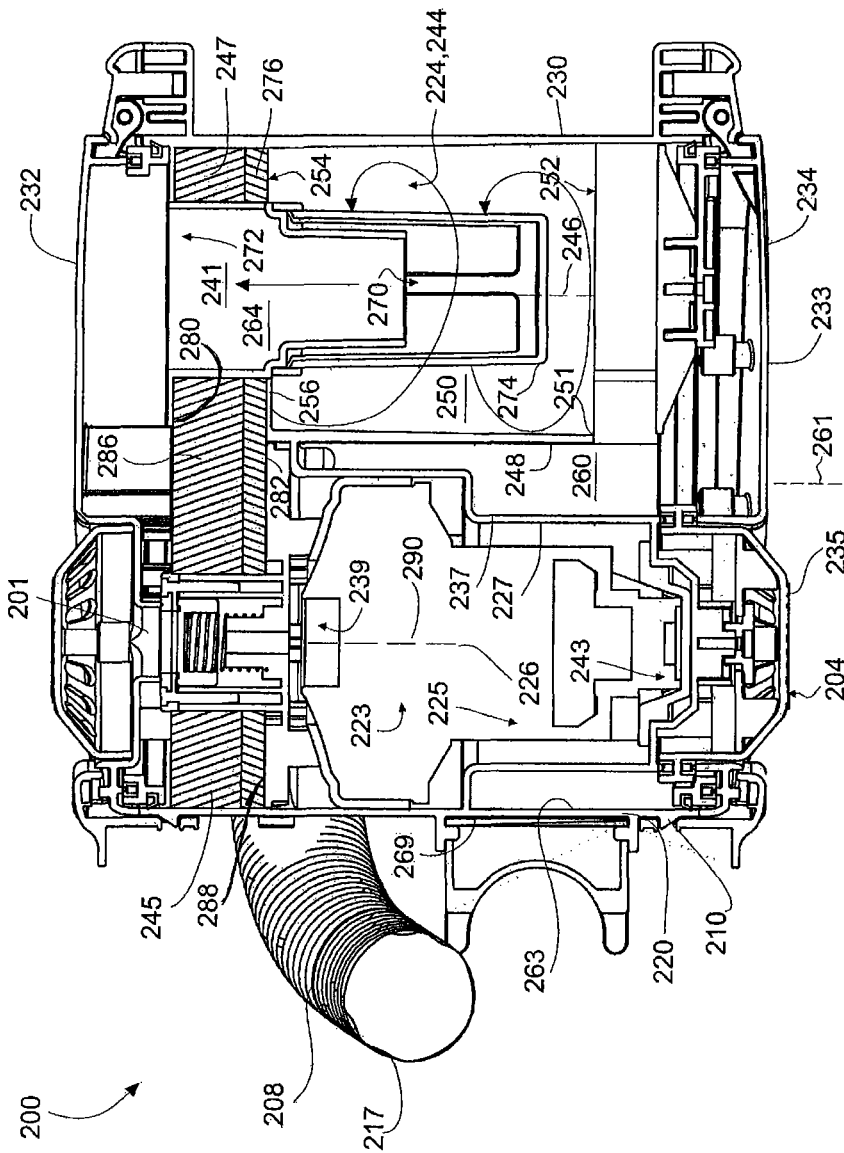

Figure 2

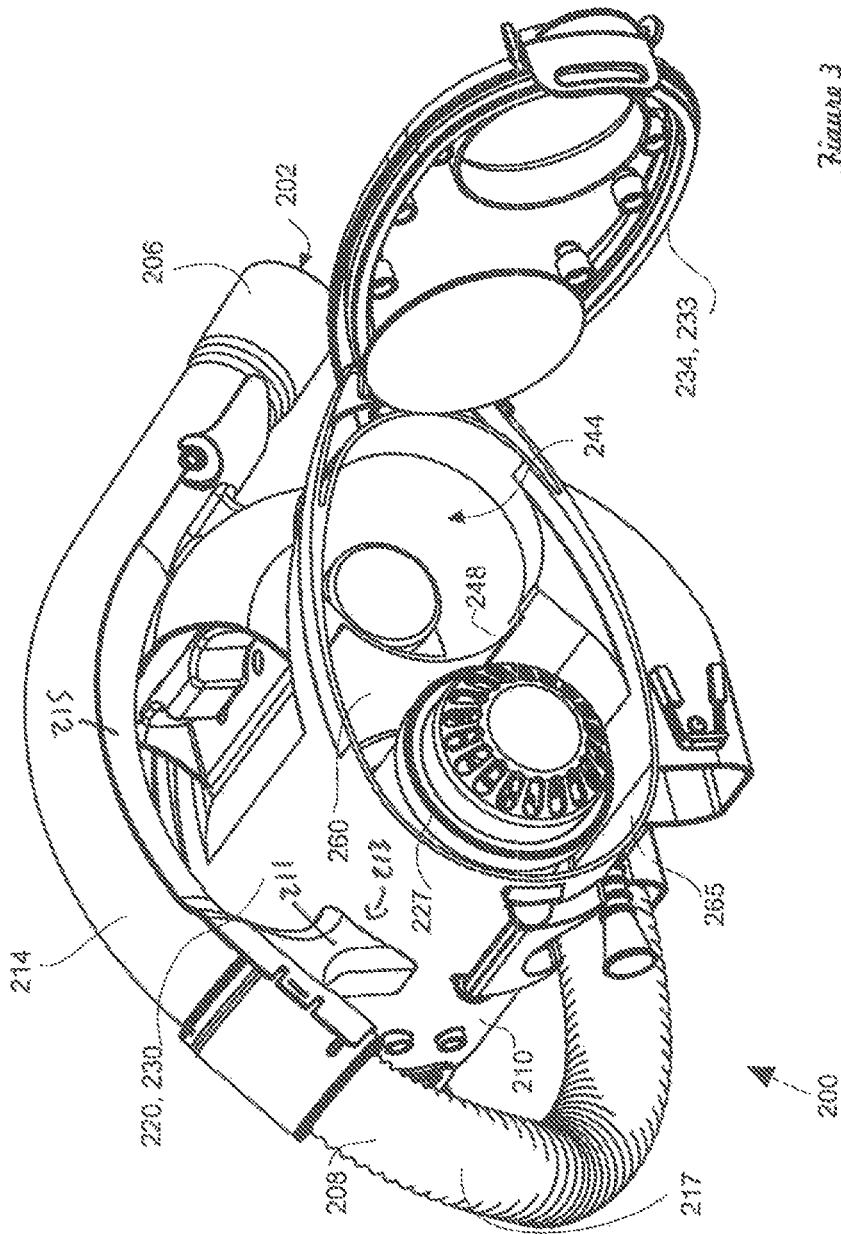

Figure 3

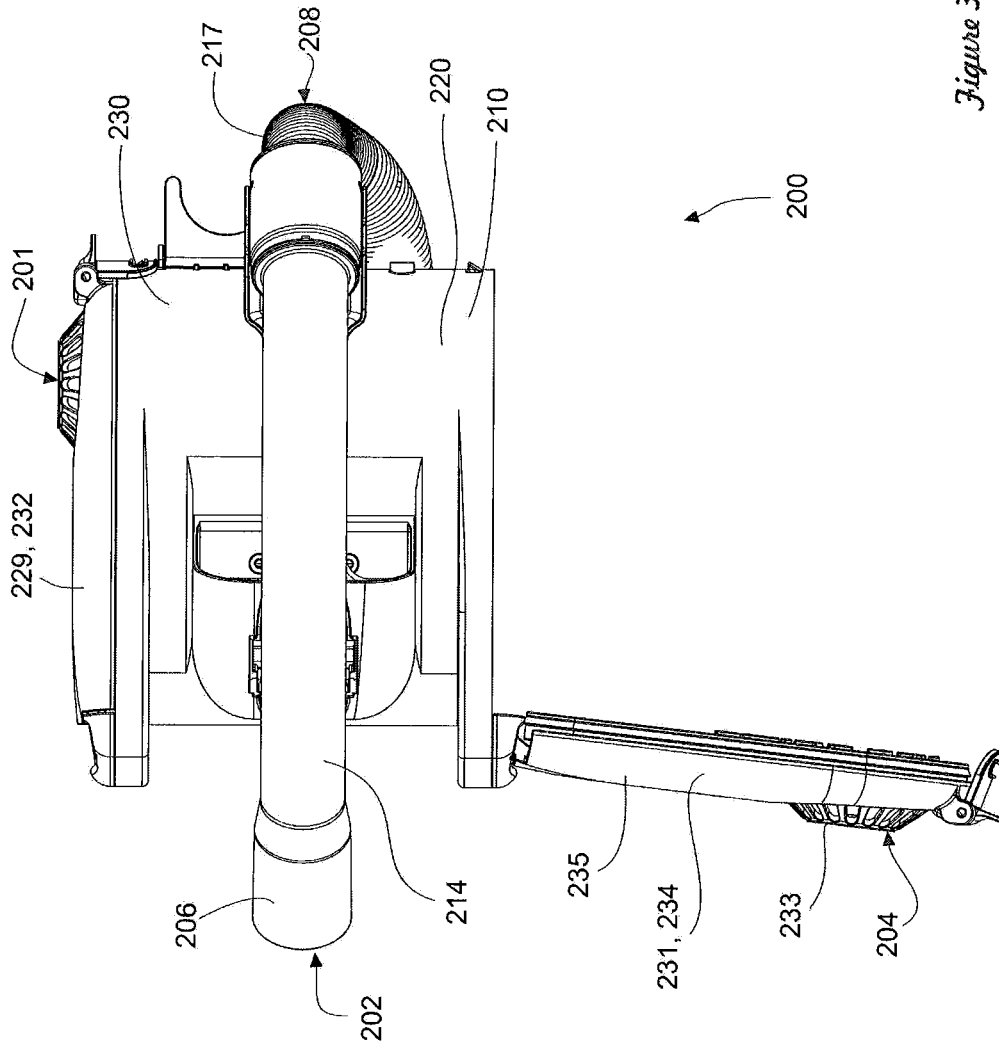

Figure 3A

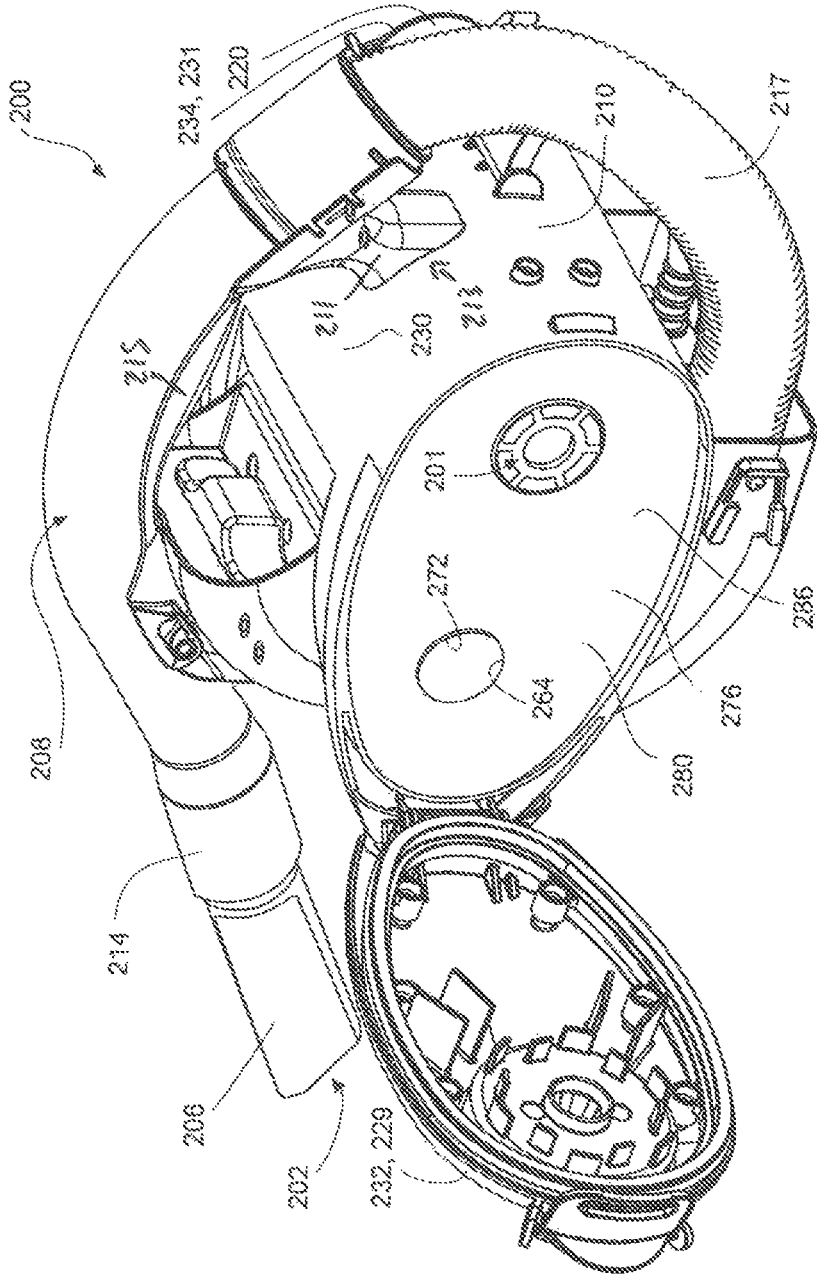

Figure 3B

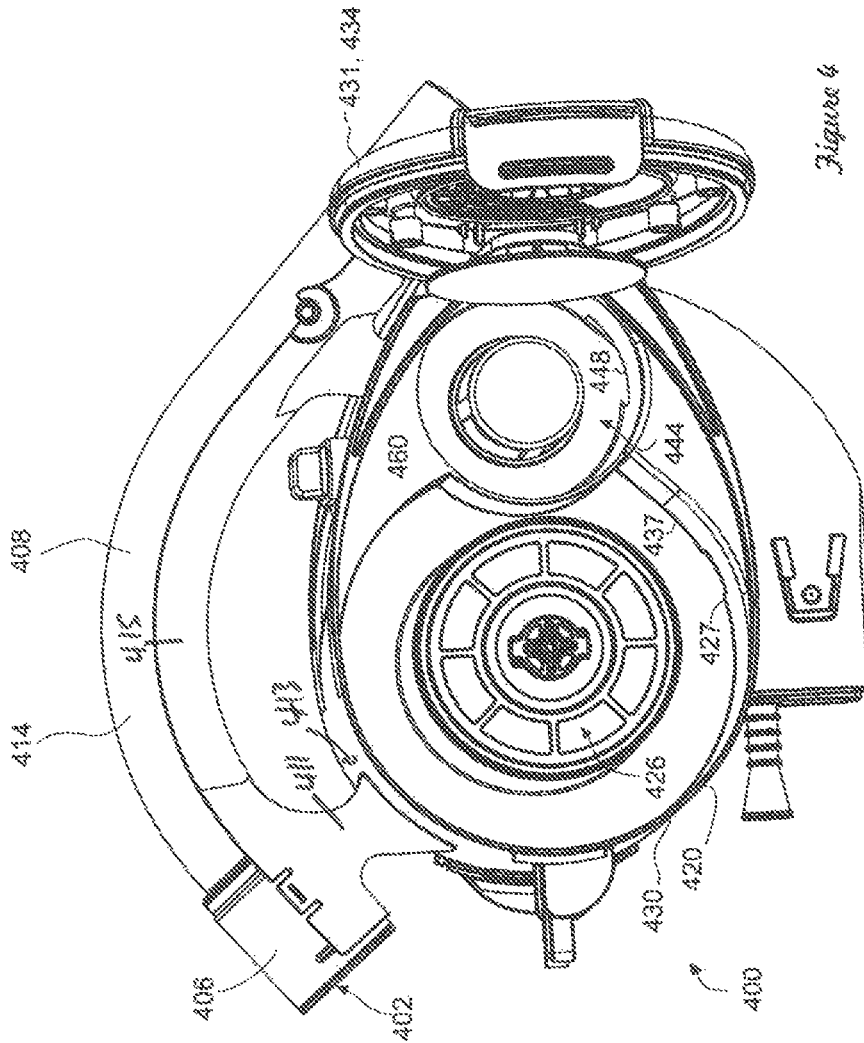

Figure 4

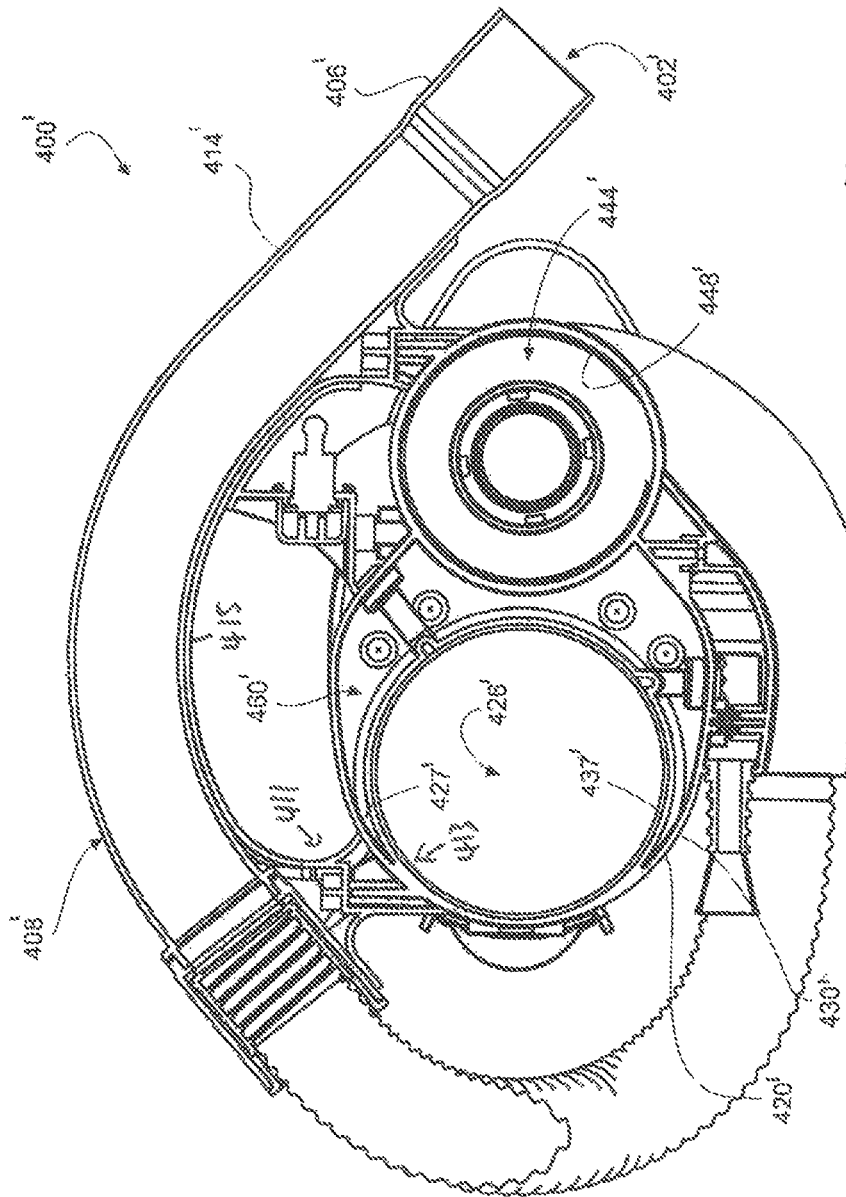

Figure 4B

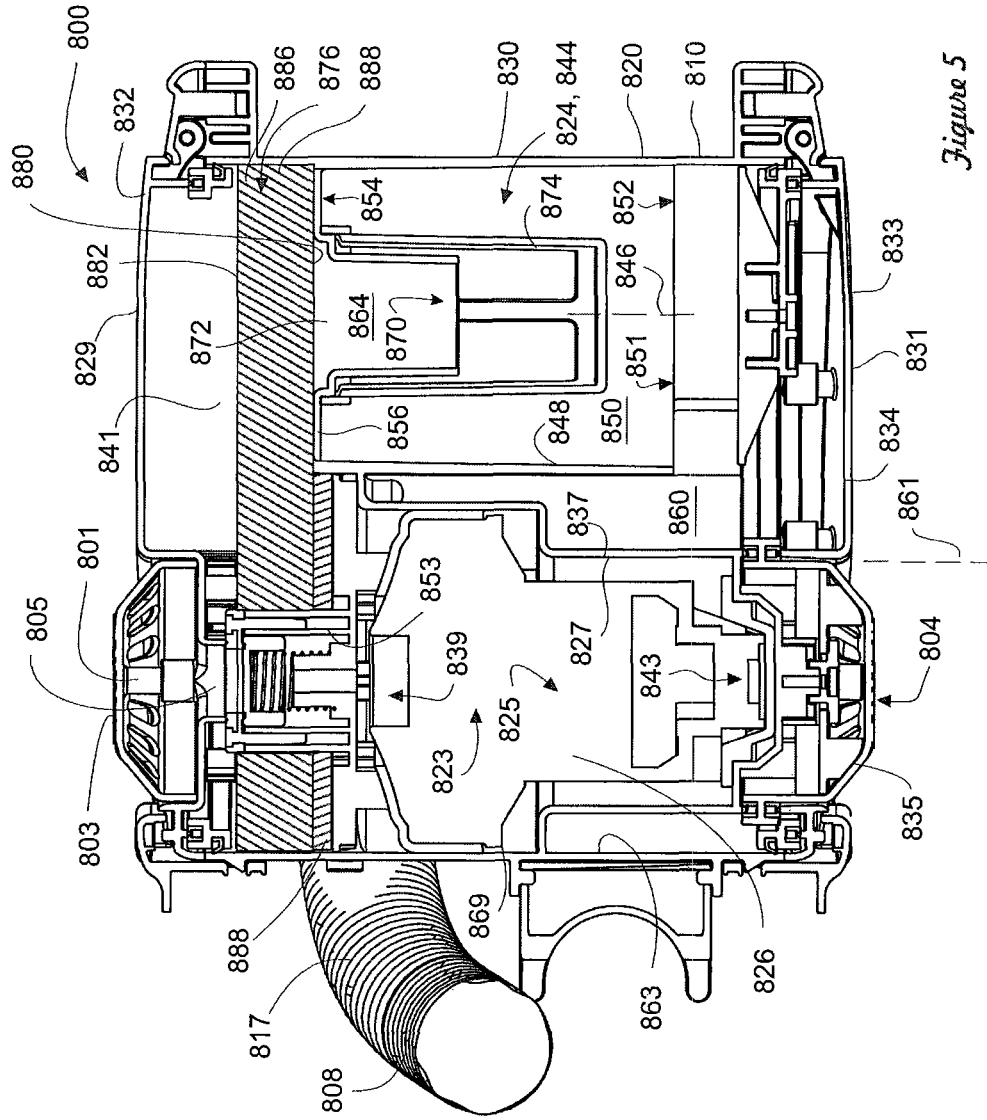
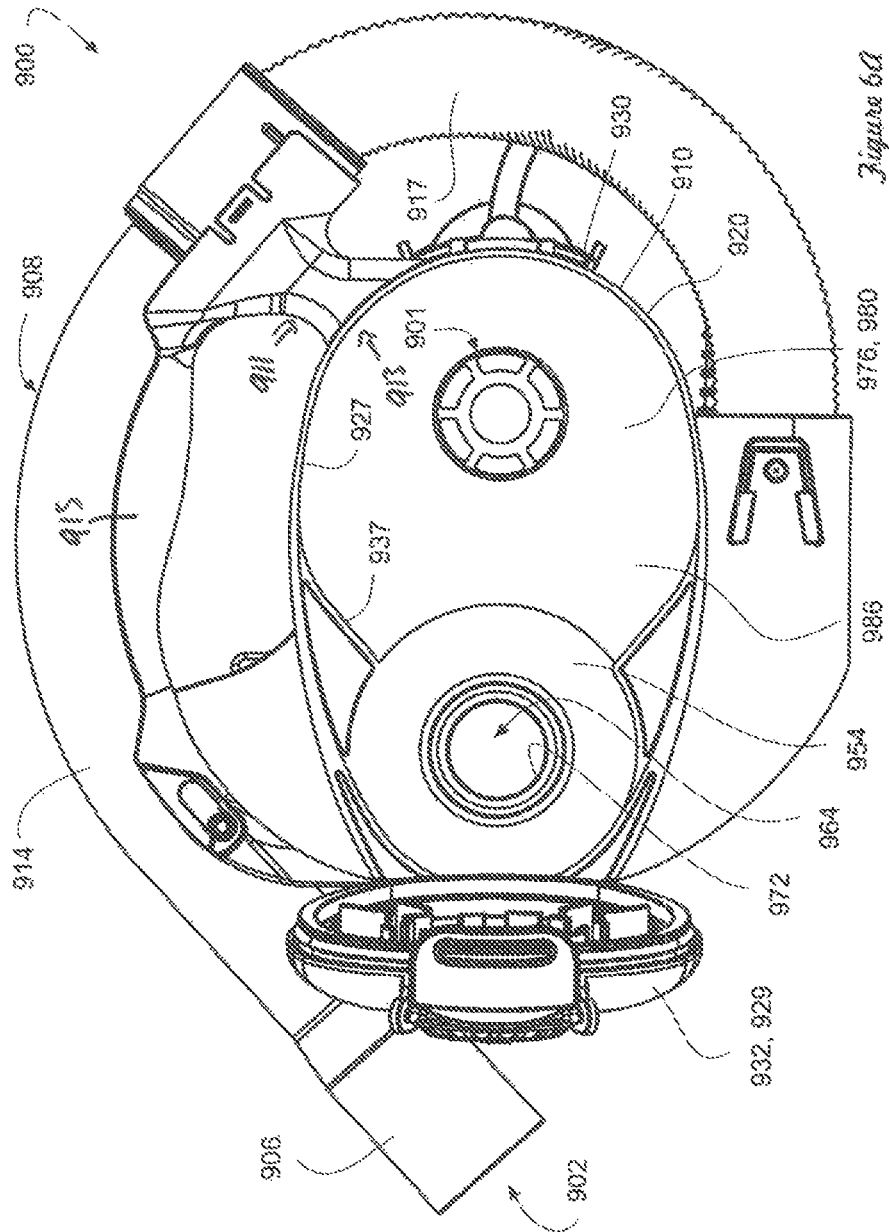

Figure 5



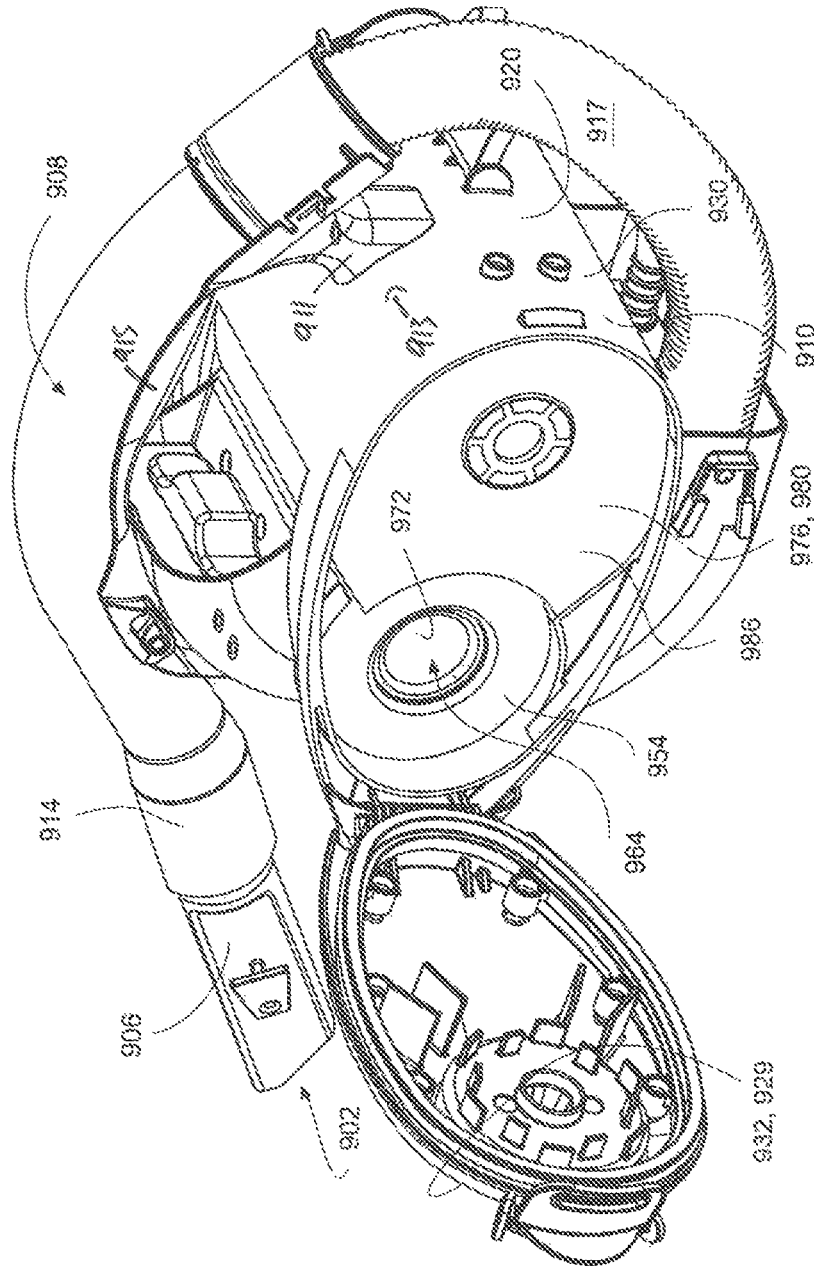

Figure 6B

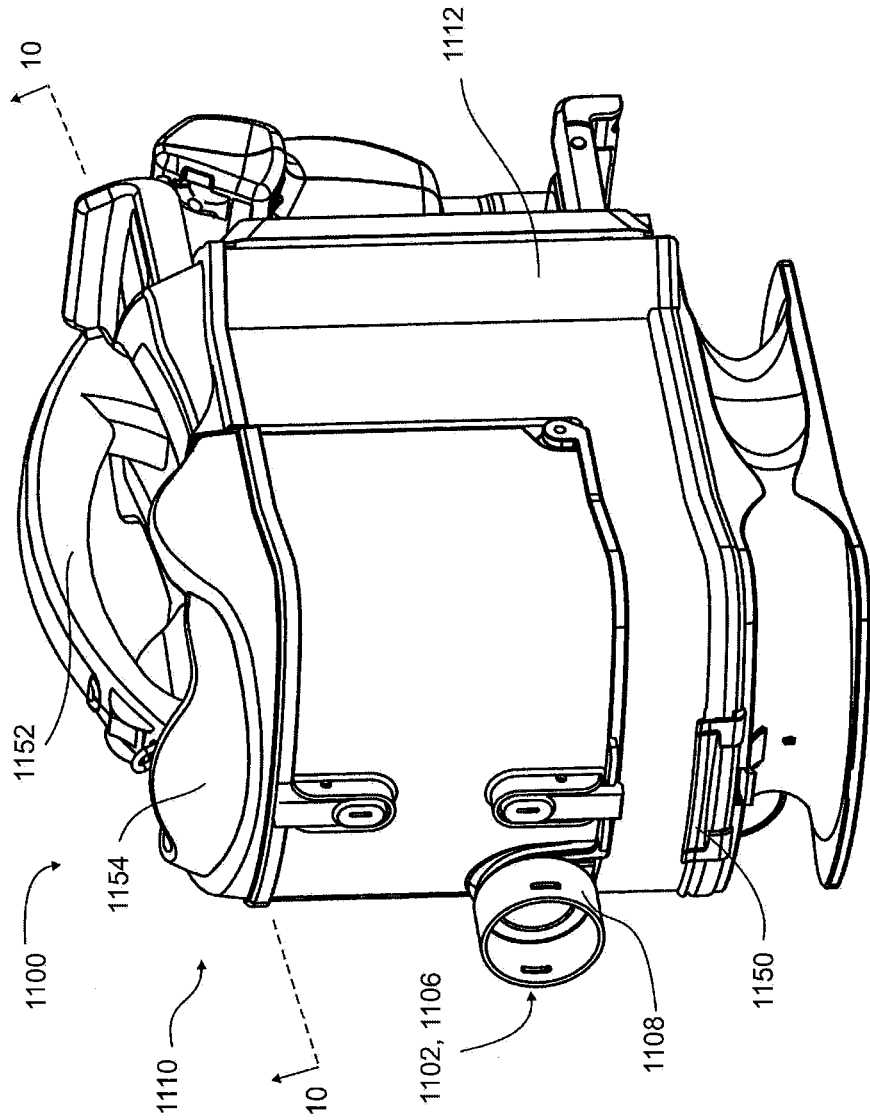

Figure 7

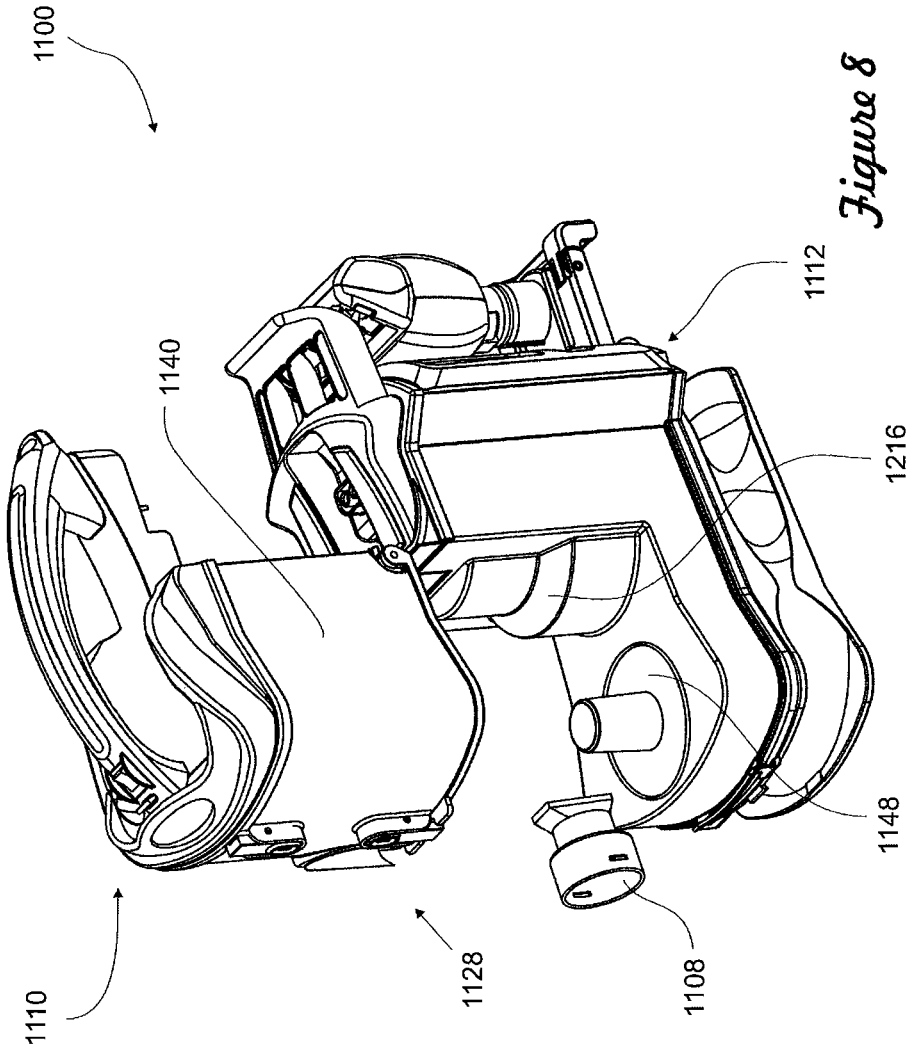

Figure 8

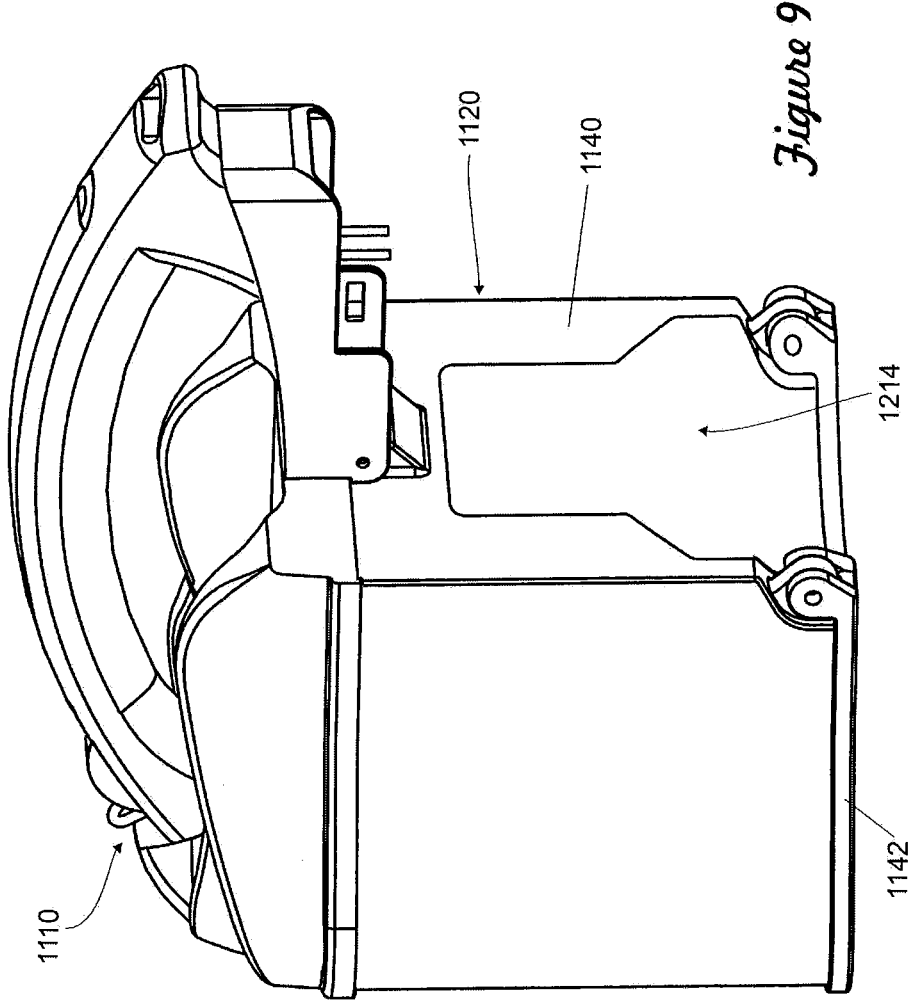

Figure 9

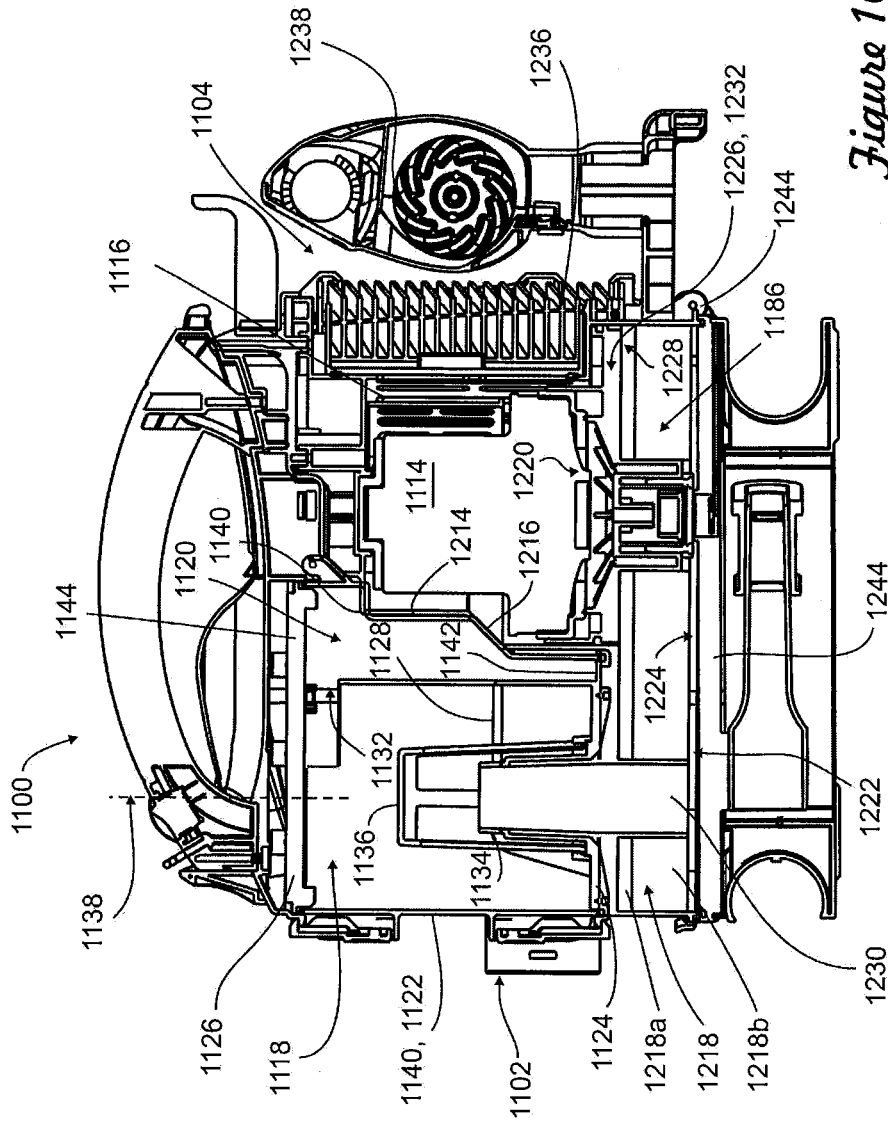

Figure 10

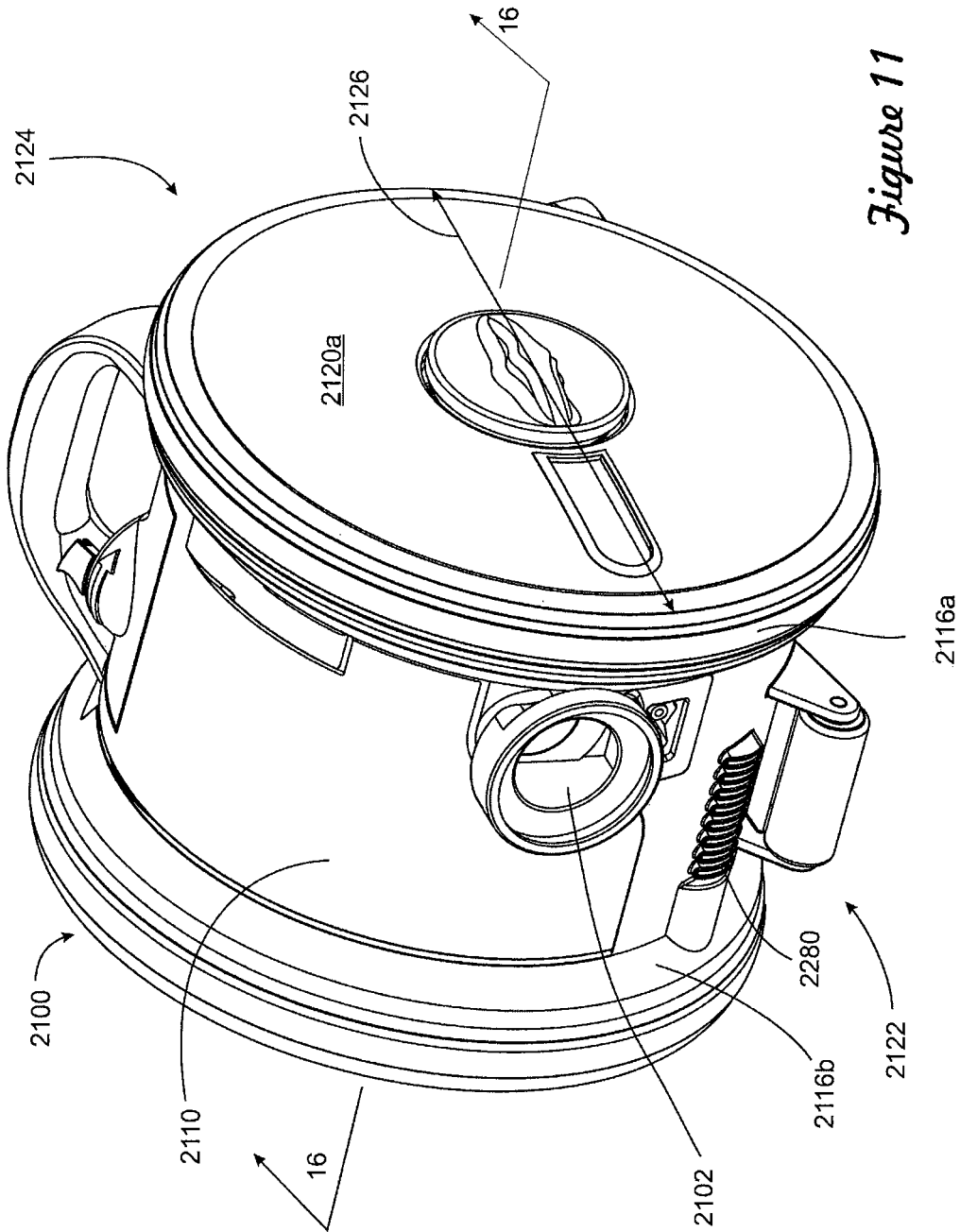

Figure 11

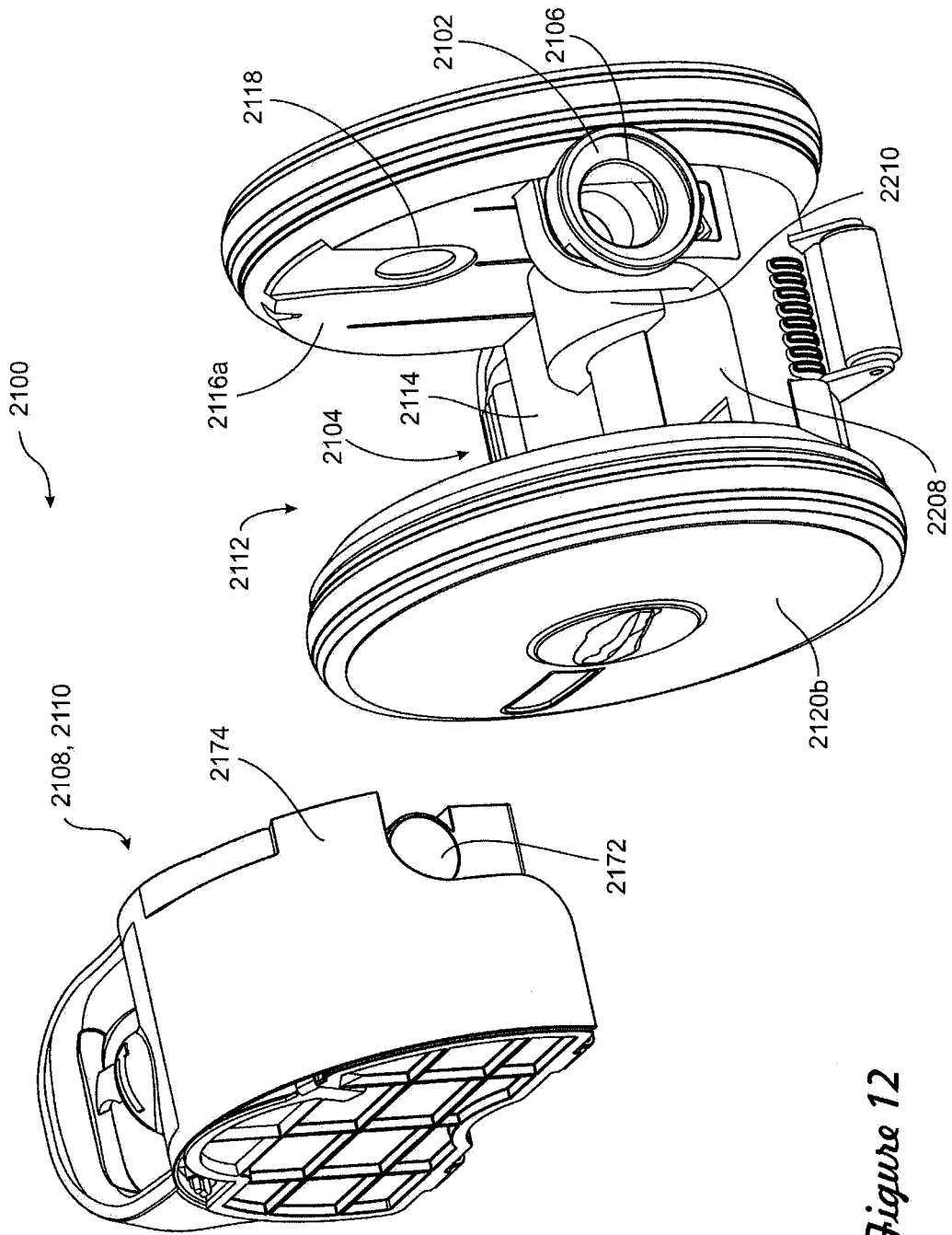

Figure 12

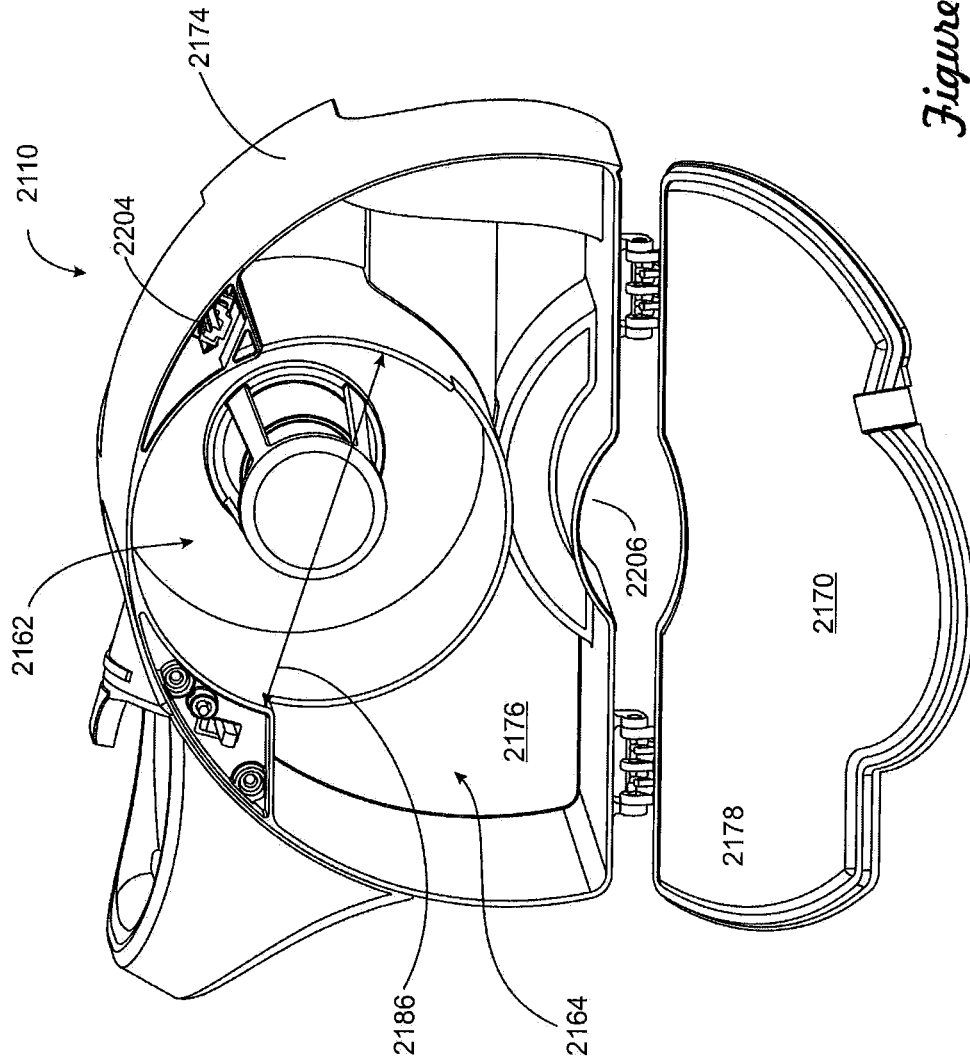

Figure 13

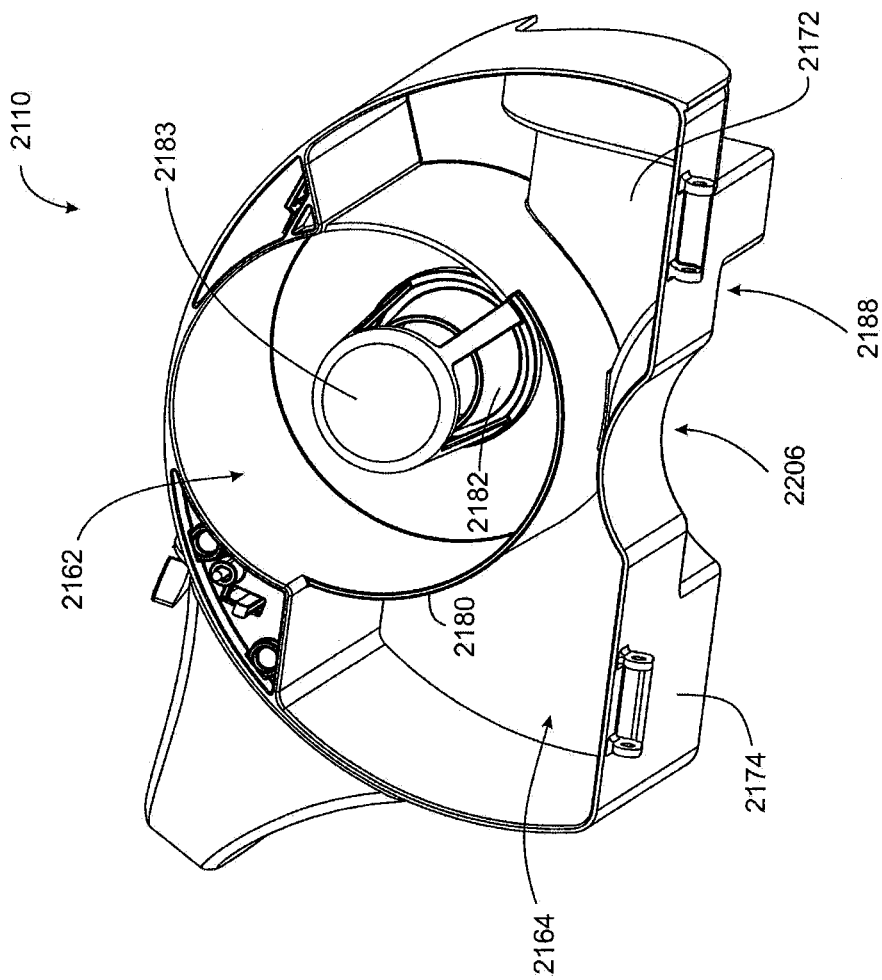

Figure 14

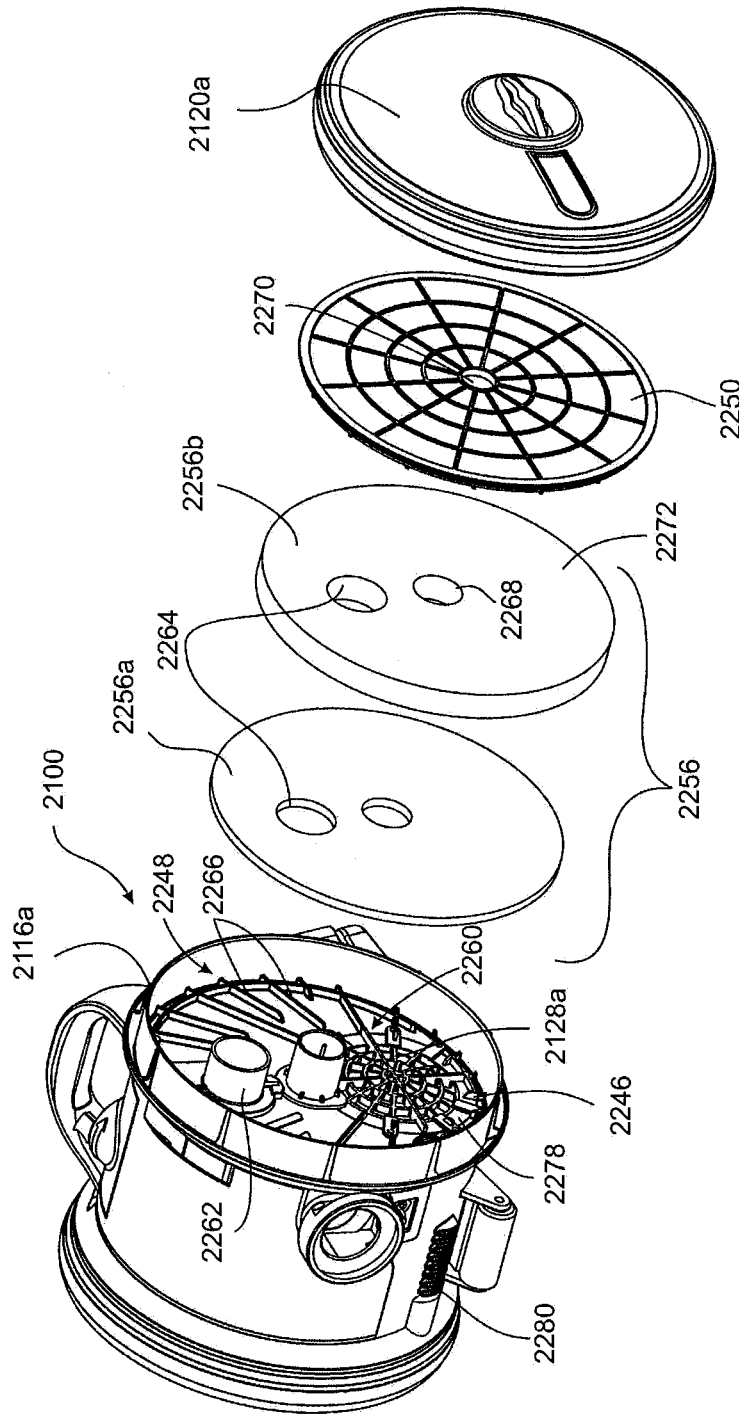

Figure 15

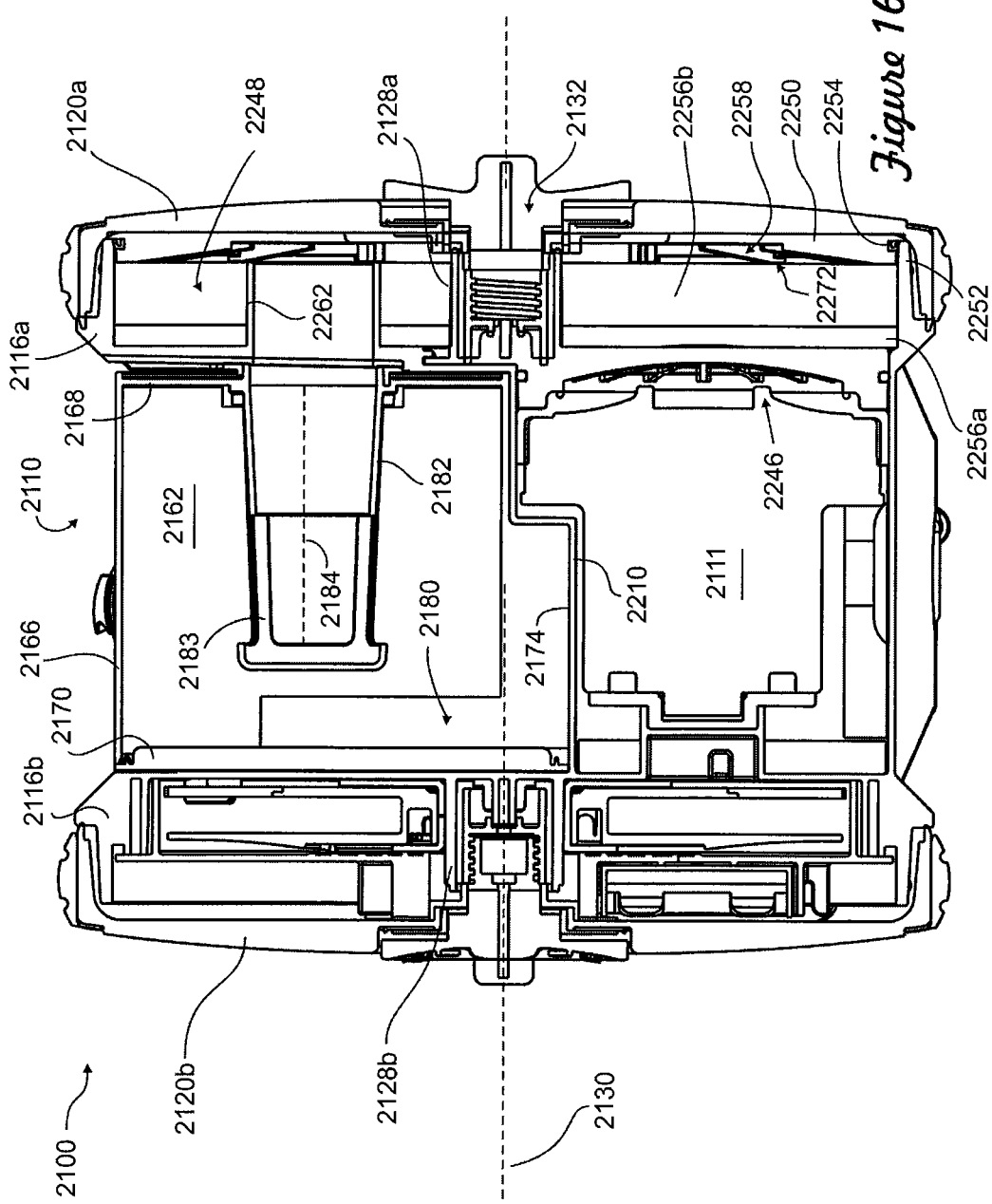

Figure 16

HAND CARRIABLE SURFACE CLEANING APPARATUS

CROSS-REFERENCE TO RELATED APPLICATIONS

This application is a continuation of U.S. patent application Ser. No. 14/994,495, filed on Jan. 13, 2016, which is a continuation of U.S. patent application Ser. No. 13/039,376, filed on Mar. 3, 2011, now U.S. Pat. No. 9,265,395, and which is a continuation in part of U.S. patent application Ser. No. 12/722,705, filed Mar. 12, 2010, now U.S. Pat. No. 8,578,555, the entirety of each of which is incorporated herein by reference.

FIELD OF INVENTION

The disclosure relates to surface cleaning apparatuses, such as vacuum cleaners.

INTRODUCTION

The following is not an admission that anything discussed below is prior art or part of the common general knowledge of persons skilled in the art.

Various constructions for surface cleaning apparatus such as vacuum cleaners are known. Currently, many surface cleaning apparatus are constructed using at least one cyclonic cleaning stage. The air is drawn into the vacuum cleaner through a dirty air inlet and conveyed to a cyclone inlet. The rotation of the air in the cyclone chamber results in some of the particulate matter in the airflow stream being disentrained from the airflow stream. This material is then collected in a dirt collection chamber, which may be at the bottom of the cyclone chamber or in a dirt collection chamber exterior to the cyclone chamber (see for example WO2009/026709 and U.S. Pat. No. 5,078,761). One or more additional cyclonic cleaning stages and/or filters may be positioned downstream from the cyclone chamber.

SUMMARY

The following summary is provided to introduce the reader to the more detailed discussion to follow. The summary is not intended to limit or define the claims.

According to one aspect, a hand surface cleaning apparatus is provided that may be operable for an enhanced period of time without a significant reduction in air flow into the dirty air inlet. In accordance with this aspect, a pre-motor filter with enhanced surface area transverse to the direction of air flow is provided.

Typically, a surface cleaning apparatus such as a hand vacuum cleaner has a pre-motor filter and a post motor filter. The post motor filter may be a HEPA filter. In such a case, the air discharged from the clean air outlet of the unit may be comparable to that discharged from a full size vacuum cleaner. As the HEPA filter is used, the air flow through the unit will decrease and the suction provided by the unit will decrease. This can impact upon the cleaning performance achieved by the vacuum cleaner. To counter this, a larger suction motor may be provided. However, that would increase the hand weight of the unit. A pre-motor filter reduces the level of entrained dirt that will reach the HEPA filter. However, the filter will become clogged with use. Increasing the surface area of the upstream side of the pre-motor filter extends the lifetime of the pre-motor filter and may therefore enhance the life of a post motor filter.

The pre-motor filter may have an enhanced surface area of its upstream side by configuring the pre-motor filter to have a larger upstream surface area than that of the suction motor inlet end. A pre-motor filter may be positioned in the suction motor casing and may therefore have a diameter that is about the same as the diameter of the fan of the suction motor. By configuring the pre-motor filter to overlie part of one or more additional components of the unit, the surface area of the upstream side is increased.

For example, a suction motor may be positioned beside a cyclone chamber and extend in the same direction of the cyclone chamber. Accordingly, one end of a cyclone chamber may be adjacent the inlet end of the suction motor (e.g., positioned in about the same plane). The pre-motor filter (preferably a foam filter and more preferably a foam filter with a felt filter downstream thereof) may be configured to overlie part or all of the cyclone chamber as well as part or all of the suction motor. Alternately, or in addition, the pre-motor filter may overlie part of the open volume between the suction motor and the cyclone chamber. If the dirt collection chamber is exterior to the cyclone chamber, e.g., it is positioned to occupy some of the open volume, then the pre-motor filter may alternately or in addition overlie part or all of the dirt collection chamber. Accordingly, a pre-motor filter with an enhanced surface area of the upstream side may be provided without substantially increasing the size of the unit. A filter with an enhanced size may be provided by providing a filter that overlies part or all of two or more of the suction motor, the dirt collection chamber and the cyclone chamber.

According to this aspect, a surface cleaning apparatus is provided. The hand surface cleaning apparatus comprises an air flow passage extending from a dirty air inlet to a clean air outlet. A suction motor is positioned in the air flow path and has an inlet end and an outlet end. At least one cyclone chamber is positioned in the air flow path and has an associated dirt collection chamber, a cyclone air inlet and a cyclone air outlet. A pre-motor filter is positioned downstream of the cyclone chamber and upstream of the suction motor. The pre-motor filter has an upstream side and a downstream side. The pre-motor filter overlies at least a portion of the suction motor and the cyclone chamber.

The cyclone chamber and the suction motor may be positioned side by side and may have generally parallel longitudinal axes.

The pre-motor filter may overlie at least half of the suction motor and the cyclone chamber. The pre-motor filter may overlie at least 75% of the suction motor and the cyclone chamber.

The pre-motor filter may have a portion that is centered over the suction motor and a portion that overlies at least half of the cyclone chamber.

The upstream side of the pre-motor filter may face the cyclone air outlet and an inlet duct of the suction motor may extend through the pre-motor filter to the downstream side of the pre-motor filter.

The cyclone air outlet may extend through the pre-motor filter to the upstream side of the pre-motor filter, and the inlet end of the suction motor may face the downstream side of the pre-motor filter.

The hand surface cleaning apparatus may further comprising an openable door positioned at a side of the hand vacuum cleaner having the cyclone air outlet and the inlet end of the suction motor. The upstream side of the pre-motor filter may be visible when the door is opened.

The pre-motor filter may be mounted to at least one of the cyclone chamber and the suction motor and the pre-motor filter may remain in position when the door is opened.

The pre-motor filter may be spaced from the door and a chamber may be provided between the pre-motor filter and the door.

BRIEF DESCRIPTION OF THE DRAWINGS

Reference is made in the detailed description to the accompanying drawings, in which:

FIG. 1 is a perspective illustration of an embodiment of a surface cleaning apparatus;

FIG. 2 is a cross section taken along line 2-2 in FIG. 1;

FIG. 3 is a perspective illustration of the surface cleaning apparatus of FIG. 1, showing a second openable door in an open configuration;

FIG. 3A is a side plan view of the surface cleaning apparatus of FIG. 1, showing a second openable door in an open configuration;

FIG. 3B is a perspective illustration of the surface cleaning apparatus of FIG. 1 showing a first openable door in an open configuration;

FIG. 4 is a plan view of an alternate embodiment of a surface cleaning apparatus, showing a second openable door in an open configuration;

FIG. 4B is a plan view of another alternate embodiment of a surface cleaning apparatus, showing a second openable door in an open configuration;

FIG. 5 is a cross section taken along the same line 2-2 through an alternate embodiment of a surface cleaning apparatus;

FIG. 6A is a plan view of an alternate embodiment of a surface cleaning apparatus, showing a first openable door in an open configuration;

FIG. 6B is a perspective illustration of the surface cleaning apparatus of FIG. 6A;

FIG. 7 is a perspective illustration of an alternate embodiment of a surface cleaning apparatus;

FIG. 8 is a perspective illustration of the surface cleaning apparatus of FIG. 7, with its cyclone bin assembly removed;

FIG. 9 is a perspective illustration of the cyclone bin assembly of FIG. 8;

FIG. 10 is a section view taken along line 10-10 in FIG. 7;

FIG. 11 is a perspective illustration of an alternate embodiment of a surface cleaning apparatus;

FIG. 12 is a perspective illustration of the surface cleaning apparatus of FIG. 11, with its cyclone bin assembly removed;

FIG. 13 is a perspective illustration of the cyclone bin assembly of FIG. 12, with one end wall in an open configuration;

FIG. 14 is a perspective illustration of the cyclone bin assembly of FIG. 13, with the one end wall removed;

FIG. 15 is a partially exploded view of the surface cleaning apparatus of FIG. 11; and

FIG. 16 is a section view taken along line 16-16 in FIG. 11.

DETAILED DESCRIPTION

Referring to FIG. 1, an embodiment of a surface cleaning apparatus 200 is shown. In this embodiment the surface cleaning apparatus 200 is a hand operable surface cleaning apparatus. The surface cleaning apparatus 200 is usable in a forward direction of motion, indicated by arrow A in FIG. 1.

A handle 215 is provided on an upper portion of the surface cleaning apparatus 200. The handle 215 is configured to be grasped by a user, and can be used to manipulate the surface cleaning apparatus 200. In the illustrated example, a first portion 211 of the handle 215 is connected to the surface cleaning apparatus 200 at a first location 213.

Referring to FIG. 2, the surface cleaning apparatus 200 has a dirty air inlet 202, a clean air outlet 204 (shown in FIG. 2), and an air flow passage extending therebetween. In the embodiment shown, the dirty air inlet 202 is provided in a nozzle 206. From the dirty air inlet 202, the airflow passage extends through the nozzle 206, and through an air conduit 208, to a suction and filtration unit 210. The clean air outlet 204 is provided in the suction and filtration unit 210. In the embodiment shown, the air conduit 108 includes a wand 214, and a hose 217.

Referring now to FIGS. 1 and 2, the suction and filtration unit 210 includes a main housing 220. A filtration member 224 is provided in the main housing 220, and the filtration member 224 is positioned in the airflow passage downstream of the dirty air inlet 202, for removing particulate matter from air flowing through the airflow passage.

A suction motor 226 is also provided in the main housing 220, downstream of the filtration member 224, for drawing air through the airflow passage. The suction motor 226 may be any suitable type of suction motor. In the embodiment shown, the suction motor 226 includes a fan 223, and a motor 225.

In the embodiment shown, the filtration member 224 and suction motor 226 are positioned side-by-side. Further, the filtration member 224 extends along an axis 246, and the suction motor extends along an axis 290, and the axes 246, 290 are generally parallel. Further, the filtration member 224 and suction motor 226 are each positioned transverse to the forward direction of motion (indicated by arrow A in FIG. 1) of the hand surface cleaning apparatus 100.

Referring to FIG. 1, in the embodiment shown, the main housing 220 includes a central wall 230, a first side wall 232, and a second side wall 234. The first side wall 232 is pivotally mounted to the central wall 230, and serves as a first openable door 229. The second sidewall 234 has a first portion 233 adjacent the filtration member 224, and a second portion 235 adjacent the suction motor 226. The second sidewall 234 is pivotally mounted to the central wall 230, and serves as a second openable door 231. Further, the second portion 235 is removable from the first portion 233.

Referring to FIG. 2, an interior wall 237 extends within the main housing 220 to separate the suction motor 226 from the filtration member 224, so that fluid communication between the filtration member 224 and the suction motor 226 may generally only occur between a filtration member air outlet 264, and a suction motor air inlet end 239, as will be described in further detail hereinbelow. The interior wall 237 generally surrounds the suction motor 226 to form a motor housing 227, and is integral with the central wall 230, so that a portion 269 of the motor housing 227 forms part of the housing 220.

Referring to FIG. 2, in the embodiment shown, the filtration member 224 is a cyclone 244. In alternate embodiments, the filtration member 224 may be, for example, a filter, such as a filter bag or a foam filter. In further alternate embodiments, the filtration member 224 may include a plurality of cyclone chambers, or a plurality of cyclonic stages.

The cyclone 244 may be of any suitable configuration. The cyclone 244 includes a cyclone wall 248 (also referred to as an outer wall 248), which is integral with the central

wall 230, and together with the central wall 230 defines a cyclone chamber 250. That is, a portion of the cyclone wall 248 forms part of the housing 220. A first end 251 of the cyclone wall 148, which is positioned towards the second sidewall 234, defines an opening 252, and an opposed second end 254 of the cyclone wall includes a second end wall 256. The cyclone wall 248 is positioned in the main housing 220 such that it is spaced from the second sidewall 234.

The open first end 252 of the cyclone serves as a dirt outlet for the cyclone 244. Material that is separated from air in the cyclone travels from the dirt outlet to an associated dirt collection chamber 260.

Referring to FIGS. 2 and 3, at least a portion of the dirt chamber 260 is preferably positioned in an open volume within the main housing 220. In the embodiment shown, the entire dirt chamber 260 is within an open volume within the main housing 220. The dirt collection chamber 260 is preferably within the main housing 220, exterior to the cyclone 244 and the suction motor 226. The dirt collection chamber extends along a longitudinal axis 261. The longitudinal axis 261 is preferably parallel to the suction motor axis 290.

Referring to FIGS. 2 and 3, at least a portion of the dirt collection chamber 260 is preferably positioned between the cyclone 244 and the suction motor 226. More preferably, at least a portion of the dirt collection chamber 260 surrounds at least a portion of the suction motor 226 and the suction motor housing 227. For example, the dirt collection chamber 260 may surround all of the suction motor 226, or only a portion of the suction motor 226, and/or all of the suction motor housing 227, or only a portion of the suction motor housing 227. As seen most clearly in FIG. 3, in the embodiment shown, the dirt collection chamber 260 fully surrounds the motor 225 of suction motor 226 and the portion suction motor housing 227 that houses the motor 225.

The dirt collection chamber 260 further preferably surrounds at least a portion of the cyclone. For example, in the embodiment shown, dirt collection chamber 260 extends around approximately one quarter of the cyclone 244. In alternate embodiments, the dirt collection chamber 260 may fully surround the cyclone 244.

In an alternate embodiment of a surface cleaning apparatus 400 shown in FIG. 4, wherein like reference numerals are used to refer to like features as in FIGS. 1 to 3, with the first digit incremented to 4, the dirt collection chamber 460 partially surrounds the motor 425 of suction motor 426 and the portion suction motor housing 427 that houses the motor 425. Further, the dirt collection chamber 460 partially surrounds the cyclone 444. Particularly, the dirt collection chamber 460 surrounds approximately three quarters of the cyclone 444. In another alternate embodiment of a surface cleaning apparatus 400' shown in FIG. 5, wherein like reference numerals are used to refer to like features as in FIG. 4, with a prime (') after the reference number, similarly to the embodiment of FIG. 4, the dirt collection chamber 460' partially surrounds the motor 425' of suction motor 426' and the portion suction motor housing 427' that houses the motor 425'. Further, the dirt collection chamber 460' partially surrounds the cyclone 444'. Particularly, the dirt collection chamber 460' surrounds approximately one quarter of the cyclone 444'.

Referring to FIG. 3, the dirt collection chamber 260 has an outer wall 263, and a portion 265 of the outer wall 263 preferably forms part of the main housing 220.

The cyclone 244 further includes a cyclone air inlet (not shown), and a cyclone air outlet 264. The cyclone air inlet

extends from a first end that is in communication with the hose 217 through the central wall 230 of the filtration member main housing 220, to a second end that is in communication with the cyclone chamber 250. The cyclone air outlet 264 extends along the axis 246, from a first end 270 that is positioned within the cyclone chamber 250, through the lower wall 156, and to a second end 272 (also referred to herein as an outlet 272 of the cyclone air outlet 264) that is in communication with a chamber 241 adjacent the first sidewall 232 of the suction and filtration unit 210. A screen 274 is preferably mounted over the first end 270 of the cyclone air outlet.

In use, air flows from the hose 217 into the cyclone chamber 250 through the cyclone air inlet. In the cyclone chamber 250, the air flows within the cyclone wall 248 in a cyclonic pattern, and particulate matter is separated from the air. The particulate matter exits the cyclone chamber 250 through the open first end 252, and settles in the dirt collection chamber 260. The air exits the cyclone chamber 250 through the cyclone air outlet 264, and enters the chamber 241.

The dirt collection chamber 260 may be emptied in any suitable manner. Referring to FIG. 3A, in the embodiment shown, the second side wall 234 is pivotally openable, so that the dirt collection chamber 260 may be opened.

Referring still to FIG. 2, the surface cleaning apparatus includes a pre-motor filter 276 positioned downstream of the cyclone 244 and upstream of the suction motor 226. The pre-motor filter 276 is preferably housed in the chamber 241, is snugly received within the central wall 230, overlies the suction motor 226 and the cyclone 244, and spaced from the first openable door 229. In the embodiment shown, the pre-motor filter 276 overlies all of the suction motor 226 and the cyclone 244. In alternate embodiments, the pre-motor filter may overlie only a portion of the suction motor 226 and the cyclone 244. Preferably, the pre-motor filter 276 overlies at least half of the suction motor 226 and the cyclone chamber 250, and more preferably, at least 75% of the suction motor 226 and the cyclone chamber 250. More preferably, the pre-motor filter 276 overlies at least half of the suction motor 226 and the cyclone 244, and more preferably, at least 75% of the suction motor 226 and the cyclone 244. Most preferably, as shown, the pre-motor filter has a portion 245 that is centered over the suction motor 226 and a portion 247 that overlies at least half of the cyclone 244. In the embodiment shown, the portion 247 overlies all of the cyclone 244.

The pre-motor filter has an upstream side 280 that faces the first sidewall 232 of the main housing 220, and an opposed downstream side 282 that faces the second sidewall 234 of the main housing 220. The pre-motor filter 276 may be any suitable type of filter. Preferably, the pre-motor filter includes a foam layer 286 and a felt layer 288.

Referring still to FIG. 2, the cyclone air outlet 264 extends through the pre-motor filter 276, so that air exiting the pre-motor filter 276 is in contact with the upstream side 280 of the pre-motor filter 286.

The air then passes through the pre-motor filter 276, towards a suction motor inlet end 239 that faces the downstream side 282 of the pre-motor filter 276. From the suction motor inlet 239, the air passes towards a suction motor outlet end 243, and out of the clean air outlet 204.

Preferably, as shown in FIG. 3B, when the first openable door 229 is open, the upstream side 280 of the pre-motor 276 is visible. By opening the openable door 229, the pre-motor filter may optionally be removed, replaced, or cleaned. Further, the pre-motor filter 276 is preferably mounted to at

least one of the cyclone 244 and the suction motor 226, and the pre-motor filter 276 remains in position when the first openable door 229 is opened. For example, as shown, the pre-motor filter 276 is frictionally mounted to the cyclone air outlet 264.

Referring still to FIG. 2, the surface cleaning apparatus further includes a bleed valve 201. The bleed valve 201 allows air to flow from the suction motor inlet 239 to the clean air outlet 204 so that the suction motor 226 does not burn out if a clog occurs.

Referring to FIGS. 4 and 5, a further alternate surface cleaning apparatus 400 is shown. The surface cleaning apparatus is similar to the surface cleaning apparatus 200, and like numerals in the surface cleaning apparatus 800 will be used to describe like features as in the surface cleaning apparatus 200, with the first digit incremented to 8.

In the surface cleaning apparatus 800, the cyclone air outlet 864 does not extend through the pre-motor filter 876. The upstream side 880 of the pre-motor filter 876 faces towards the second sidewall 834 of the housing 820 and faces the cyclone air outlet 864, and the downstream side 882 of the pre-motor filter 876 faces the first sidewall 834. Air passes out of the second end 872 of the cyclone air outlet 864, through the pre-motor filter, and into the chamber 841.

The suction motor 826 has a suction motor inlet duct 853 that extends through the pre-motor filter 876 to the downstream side 882 of the pre-motor filter 876.

In this embodiment, the bleed valve 801 is provided in the openable door, and has an air outlet 805 that is within the chamber 841, so that it is in communication with the suction motor air inlet end 839.

When the openable door is open, the suction motor inlet 839 is visible, and the downstream side 882 of the pre-motor filter 876 is visible.

Referring to FIGS. 6A and 6B, a further alternate surface cleaning apparatus 900 is shown. The surface cleaning apparatus is similar to the surface cleaning apparatus 200, and like numerals in the surface cleaning apparatus 900 will be used to describe like features as in the surface cleaning apparatus 200, with the first digit incremented to 9.

In the surface cleaning apparatus 900, the post motor filter 976 overlies only the motor (not shown) and the motor housing 927, and does not overlie the cyclone 944. The cyclone outlet 964 is in communication with the upstream side 980 of the post motor filter 976, which faces towards the first side 232 of the housing 220. The downstream side of the post motor filter 976 faces the motor inlet end (not shown) and the second side 234 of the housing 920. A bleed valve 901 extends through the post motor filter 976.

Referring to FIGS. 7-10, a further alternate surface cleaning apparatus 1100 is shown. In the embodiment illustrated, the surface cleaning apparatus 1100 is a hand operable surface cleaning apparatus. In alternate embodiments, the surface cleaning apparatus may be another suitable type of surface cleaning apparatus, including, for example, an upright vacuum cleaner, a canister vacuum cleaner, a stick vacuum cleaner, a wet-dry vacuum cleaner and a carpet extractor.

Referring to FIG. 10, the surface cleaning apparatus 1100 has a dirty air inlet 1102, a clean air outlet 1104 and an airflow passage extending therebetween. In the embodiment shown, the dirty air inlet 1102 is the air inlet 1106 of a suction hose connector 1108 that can be connected to the downstream end of, e.g., a flexible suction hose or other type of cleaning accessory tool, including, for example, a wand and a nozzle. From the dirty air inlet 1102, the airflow passage extends through an air treatment member that can

treat the air in a desired manner, including for example removing dirt particles and debris from the air. In the illustrated example, the air treatment member comprises a cyclone bin assembly 1110. The cyclone bin assembly 1110 is mounted on a body 1112. Alternatively, or in addition, the air treatment member can comprise a bag, a filter or other air treating means. A suction motor 1114 that is mounted within the body 1112 and is in fluid communication with the cyclone bin assembly 1110.

The clean air outlet 1104, which is in fluid communication with an outlet of the suction motor 1114, is provided in the body 1112. In the illustrated example, the dirty air inlet 1102 is located toward the front of the surface cleaning apparatus 1100, and the clean air outlet 1104 is located toward the rear.

In the illustrated example, cyclone bin assembly 1110 includes a cyclone chamber 1118 and a dirt collection chamber 1120. The cyclone chamber 1118 is bounded by a sidewall 1122, a first end wall 1124 and a second end wall 1126 that are configured to provide an inverted cyclone configuration. A tangential air inlet 1128 is provided in the sidewall of the cyclone chamber 1118 and is in fluid communication with the air outlet of the hose connector 1108. Air flowing into the cyclone chamber 1118 via the tangential air inlet 1128 can circulate around the interior of the cyclone chamber 1118 and dirt particles and other debris can become disentrained from the circulating air.

A slot 1132 formed between the sidewall 1122 and the second end wall 1126 serves as a cyclone dirt outlet 1132. Debris separated from the air flow in the cyclone chamber 1118 can travel from the cyclone chamber 1118, through the dirt outlet 1132 to the dirt collection chamber 1120.

Air can exit the cyclone chamber 1118 via an air outlet. In the illustrated example, the cyclone air outlet includes a vortex finder 1134. Optionally, a removable screen 1136 can be positioned over the vortex finder 1134. The cyclone chamber 1118 extends along a longitudinal cyclone axis 1138. In the example illustrated, the longitudinal cyclone axis 1138 is aligned with the orientation of the vortex finder 1134.

The dirt collection chamber 1120 comprises a sidewall 1140, a first end wall 1142 and an opposing second end wall 1144. In the illustrated example, at least a portion of the dirt collection chamber sidewall 1140 is integral with a portion of the cyclone chamber sidewall 1122, and at least a portion of the first cyclone end wall 1124 is integral with a portion of the first dirt collection chamber end wall 1142.

Referring to FIG. 8, the cyclone bin assembly 1110 is optionally detachably connected to the body 1112. In the example illustrated, the cyclone bin assembly 1110 is detachably mounted on a platform 1148. A releasable latch 1150 can be used to secure a front edge of the cyclone bin assembly 1110 to the body 1112.

Referring to FIG. 7, a handle 1152 is provided on the top of the cyclone bin assembly 1110. The handle 1152 is configured to be grasped by a user. When the cyclone bin assembly 1110 is mounted on the body 1112, the handle 1152 can be used to manipulate the surface cleaning apparatus 1100. When the cyclone bin assembly 1110 is removed from the body 1112, the handle 1152 can be used to carry the cyclone bin assembly 1110, for example to position the cyclone bin assembly 1110 above a waste receptacle for emptying. In the illustrated example, the handle 1152 is integral with a lid 1154 of the cyclone bin assembly 1110.

Referring to FIGS. 9 and 10, the dirt collection chamber sidewall 1140 comprises a recess 1214 that is shaped to receive a corresponding portion of the body 1112. In the illustrated example, the recess 1214 is shaped to receive a

portion of the motor housing **1216** surrounding the suction motor **1114**. In this example, at least a portion of the dirt collection chamber **1120** is positioned between the cyclone chamber **1118** and the suction motor **1114**. Preferably, at least a portion of the dirt collection chamber **1120** surrounds at least a portion of the suction motor **1114** and, if a suction motor housing is provided, the suction motor housing **1216**. In the illustrated example, the dirt collection chamber **1120** surrounds only a portion of the motor housing **1216**. The shape of the recess **1214** is preferably selected to correspond to the shape of the suction motor housing **1216** so as to maximize the size of the dirt collection chamber for the foot print of the vacuum cleaner. Configuring the dirt collection chamber **1120** to at least partially surround the suction motor housing **216** may help reduce the overall length of the surface cleaning apparatus **1100**, and/or may help increase the capacity of the dirt collection chamber **1120**.

Referring to FIG. **10**, the dirt collection chamber **1120** also surrounds at least a portion of the cyclone chamber **1118**. Optionally, the dirt collection chamber **1120** can be configured to completely surround the cyclone chamber **1118**.

Air exiting the cyclone chamber **1118** flows to a suction motor **1114** inlet via an filter chamber **1186**. The filter chamber **1186** is provided downstream from the cyclone air outlet. In the illustrated example, the filter chamber **1186** extends over substantially the entire lower portion of the body **1112** and overlies substantially all of the cyclone chamber **1118**, dirt collection chamber **1120** and suction motor **1114**.

A pre-motor filter **1218** is provided in the filter chamber **1186** to filter the air before it enters the suction motor inlet **1220**. The pre-motor filter **1218** is sized to cover the entire area of the filter chamber **1186**, and overlies substantially all of the cyclone chamber **1118**, dirt collection chamber **1120** and suction motor **1114**. Preferably, the cross sectional area (in the direction of air flow) of the pre-motor filter **1218** is greater than the cross sectional area of the cyclone chamber **1118** and the suction motor **1114**. In the illustrated example, the pre-motor filter **1218** comprises first and second pre-motor filters **1218a**, **1218b**. The filter chamber **1186** comprises an air inlet chamber **1222** on the upstream side **1224** of the pre-motor filter **1218**, and an air outlet chamber **1226** on the downstream side **1228** of the pre-motor filter **1218**. Air can travel from the air inlet chamber **1222** to the air outlet chamber **1226** by flowing through the air-permeable pre-motor filter **1218**. It will be appreciated that the larger the cross sectional area of the upstream face of the filter, the greater the capacity of the filter to filter particulates without the filter becoming clogged. Accordingly, it is preferred to make pre-motor filter **1218** as large as possible. Accordingly, it is preferred that filter chamber **1186** is as large as possible (i.e. it overlies all of an end face of the cyclone chamber, dirt collection chamber and suction motor) and that the pre-motor filter **1218** extends over the full transverse extent of filter chamber **1186**. It will be appreciated that the filter chamber **1186** may overlie only a portion of the end face of the cyclone chamber, dirt collection chamber and suction motor but may still provide a larger upstream surface area than is the filter only overlies the cyclone chamber.

The lower side of the air filtration chamber comprises a filtration chamber end wall **1244**. Optionally, the first end wall **1244** of the filter chamber **1186** can be openable to allow a user to access the pre-motor filter **1218**. In the illustrated example, the filter chamber end wall **1244** is pivotally connected to the body **1112** by a hinge **1246** and can pivot to an open position. The releasable latch **1150** can

be used to secure in a closed position. The latch **1150** can connect the filter chamber end wall **1244** to the cyclone bin assembly **1110**. As exemplified and discussed hereafter, the upstream side of pre-motor filter **1218** is visible when filter chamber end wall **1244** is in the open position and accordingly, a user may readily detect if the pre-motor filter **1218** requires cleaning or changing.

The air inlet chamber **1222** is fluidly connected to the cyclone chamber air outlet by an inlet conduit **1230** that extends through the pre-motor filter **1218**. In the illustrated example the inlet conduit **1230** comprises an extension of a vortex finder insert. The air outlet chamber **1226** is in fluid communication with the inlet **1220** of the suction motor **1114**. The pre-motor filter **1218** may be supported by a plurality of support ribs **1232** extending through the air outlet chamber **1226**. Gaps or cutouts can be provided in the ribs **1232** to allow air to circulate within the air outlet chamber **1226** and flow toward the suction motor inlet **1220**. From the suction motor inlet **1220**, the air is drawn through the suction motor **1114** and ejected via a suction motor outlet **1116**. Optionally, a post-motor filter **1236** (for example a HEPA filter) can be provided downstream from the suction motor outlet **1116**, between the suction motor outlet **1116** and the clean air outlet **1104**. A detachable grill **1238** can be used to retain the post-motor filter **1236** in position, and allow a user to access the post-motor filter **1236** for inspection or replacement.

Referring to FIGS. **11** to **16**, another embodiment of a surface cleaning apparatus **2100** is shown. In the embodiment illustrated, the surface cleaning apparatus **2100** is a canister vacuum cleaner. The surface cleaning apparatus **2100** has a dirty air inlet **2102**, a clean air outlet **2104** and an airflow passage extending therebetween. In the embodiment shown, the dirty air inlet **2102** is the air inlet of a suction hose connector **2106** that can be connected to the downstream end of a flexible suction hose or other type of cleaning accessory tool, including, for example, a surface cleaning head, a wand and a nozzle. From the dirty air inlet **2102**, the airflow passage extends through an air treatment member **2108** that can treat the air in a desired manner, including for example removing dirt particles and debris from the air. In the illustrated example, the air treatment member **2108** comprises a cyclone bin assembly **2110**. Alternatively, or in addition, the air treatment member **2108** can comprise a bag, a filter or other air treating means. A suction motor **2111** (FIG. **16**) is mounted within a body **2112** of the surface cleaning apparatus **2100** and is in fluid communication with the cyclone bin assembly **2110**. In the illustrated example, the body **2112** of the surface cleaning apparatus **2100** is a rollable, canister-type body that comprises a platform **2114** and two opposing sidewalls **2116a**, **2116b** that cooperate to define a central cavity **2118**. The surface cleaning apparatus **2100** also comprises two main side wheels **2120a**, **2120b**, rotatably coupled to the sidewalls **2116a** and **2116b**, respectively.

The clean air outlet **2104**, which is in fluid communication with an outlet of the suction motor **2111**, is provided in the body **2112**. In the illustrated example, the dirty air inlet **2102** is located toward the front **2122** of the surface cleaning apparatus **2100**, and the clear air outlet is located toward the rear **2124**.

In the illustrated example, the body sidewalls **2116a**, **b** are generally circular and cover substantially the entire side faces of the surface cleaning apparatus **2100**. One main side wheel **2120a**, **2120b** is coupled to the outer face of each body sidewall **2116a** and **2116b**, respectively. Optionally, the side wheels **2120a**, **2120b** may have a larger diameter

11

2126 than the body sidewalls 2116a, b and can completely cover the outer faces of the sidewalls 2116a, b. Referring to FIG. 16, each side wheel 2120a, b is rotatably supported by a corresponding axel 2128a, 2128b, which extends from the body sidewalls 2116a and 2116b, respectively. The main side wheels 2120a and 2120b are rotatable about a primary axis of rotation 2130. In the illustrated example, the primary axis of rotation 2130 passes through the cyclone bin assembly 2110.

Optionally, at least one of the side wheels 120a, b can be detachable from the body 112. Referring to FIG. 15, in the illustrated example side wheel 2120a is detachably coupled to its corresponding axels 2128a by a threaded hub assembly 2132a, and can be removed from the body 2112. Removing the side wheel 2120a from the body 112, or otherwise positioning them in an open configuration, may allow a user to access a variety of components located in compartments between the side wheels 120a and 120b and the corresponding sidewalls 116a and 116b, as explained in greater detail below.

FIGS. 12, 13, 14 and 16 illustrated an example of a cyclone bin assembly 2110 includes a cyclone chamber 2162 and a dirt collection chamber 2164 in accordance with one embodiment. The cyclone bin assembly 2110 is detachably mounted in the cavity 2118, laterally between the sidewalls 2116a, 2116b and side wheels 2120a, 2120b. Positioning the cyclone bin assembly 2110 in the cavity 2118, between the body sidewalls 2116a, 2116b may help protect the cyclone bin assembly 2110 from side impacts, for example if the surface cleaning apparatus 2100 contacts a piece of furniture or other obstacle. Preferably, the body sidewalls 2116a, 2116b have a larger cross-sectional area than the cyclone bin assembly 2110. More preferably, the transverse faces of the cyclone bin assembly 2110 are entirely covered by the body sidewalls 2116a, 2116b.

In the illustrated example, the cyclone chamber 2162 is bounded by a sidewall 2166, a first end wall 2168 and a second end wall 2170. A tangential air inlet 2172 is provided in the sidewall of the cyclone chamber 2162 and is in fluid communication with the dirty air inlet 2102. Air flowing into the cyclone chamber 2162 via the air inlet can circulate around the interior of the cyclone chamber 2162 and dirt particles and other debris can become disentrained from the circulating air.

A slot 2180 formed between the sidewall 2166 and the second end wall 2170 serves as a cyclone dirt outlet 2180. Debris separated from the air flow in the cyclone chamber 2162 can travel from the cyclone chamber 2162, through the dirt outlet 2180 to the dirt collection chamber 2164.

Air can exit the cyclone chamber 2162 via an air outlet. In the illustrated example, the cyclone air outlet includes a vortex finder 2182. Optionally, a removable screen 2183 can be positioned over the vortex finder 2182. The cyclone chamber 2162 extends along a longitudinal cyclone axis 2184. In the example illustrated, the longitudinal cyclone axis is aligned with the orientation of the vortex finder 2182 and is generally transverse to the direction of movement of the surface cleaning apparatus 2100. The cyclone chamber 2162 has a generally circular cross sectional shape (taken in a plane perpendicular to the cyclone axis) and has a cyclone diameter 2186.

The dirt collection chamber 2164 comprises a sidewall 2174, a first end wall 2176 and an opposing second end wall 2178. In the illustrated example, at least a portion of the dirt collection chamber sidewall 2174 is integral with a portion of the cyclone chamber sidewall 2166, and at least a portion

12

of the first cyclone end wall 2168 is integral with a portion of the first dirt collection chamber end wall 2176.

Referring to FIGS. 12 and 14, a lower surface 2188 of the cyclone bin assembly 2110 is configured to rest on the platform 2114, and the first and second end walls 2168, 2170 of the cyclone bin assembly 2110 are shaped to engage the inner surfaces of the body sidewalls 2116a, 2116b, respectively. The upper portion of the cyclone bin (as viewed when installed in the cavity 2118) can have a radius of curvature that generally corresponds to the radius of curvature of the body sidewalls 2116a, 2116b and the side wheels 2120a, 2120b. Matching the curvature of the cyclone bin assembly 2110 with the curvature of the side wheels 120a, 120b may help facilitate mounting of the cyclone bin assembly 2110 within the body 2112, so that the walls of the cyclone bin assembly 2110 do not extend radially beyond the body sidewalls 2116a, 2116b or main side wheels 2120a, 2120b.

Referring to FIG. 13, the second dirt collection chamber end wall 2178 is preferably pivotally connected to the dirt collection chamber sidewall 2174. The second dirt collection chamber end wall 2178 can be opened to empty dirt and debris from the interior of the dirt collection chamber 2164. Optionally, the second cyclone end wall 2170 is integral with and is openable with the second dirt collection chamber end wall 2178. Opening the second cyclone end wall 2170 can allow dirt and debris to be emptied from the cyclone chamber 2162. The second dirt collection chamber sidewall 2178 can be retained in the closed position by a releasable latch 2204. Optionally, the screen 2183 and/or the vortex finder 2182 can be removable from the cyclone chamber 2162 and can be removed when the second dirt collection chamber end wall 2178 is open.

Referring to FIGS. 13 and 14, the dirt collection chamber sidewall 2174 comprises a recess 2206 that is shaped to receive a corresponding portion of the body 2112. Referring to FIG. 12, in the illustrated example, the platform 2114 comprises a generally planar bearing surface 2208 for supporting the cyclone bin assembly 2110. The platform 2114 also comprises at least a portion of the suction motor housing 2210 surrounding the suction motor 2111. In this example, the recess 2206 in the dirt collection chamber sidewall 2174 is shaped to receive the portion of the motor housing 2210 projecting above the planar bearing surface 2208.

Preferably, at least a portion of the dirt collection chamber 2164 surrounds at least a portion of the suction motor 2111 and the suction motor housing 2210. In this example, at least a portion of the dirt collection chamber 2164 is positioned between the cyclone chamber 2162 and the suction motor housing 2210 (and the suction motor 2111 therein). Configuring the dirt collection chamber 2164 to at least partially surround the suction motor housing 2210 may help reduce the overall size of the surface cleaning apparatus 2100, and/or may help increase the capacity of the dirt collection chamber 2164. The dirt collection chamber 2164 also surrounds at least a portion of the cyclone chamber 2162.

Referring to FIGS. 15 and 16, air exiting the cyclone chamber 2162 flows to a suction motor inlet 2246 via a filter chamber 2248. The filter chamber 2248 is provided downstream from the cyclone air outlet. In the illustrated example, the filter chamber 2248 comprises a recessed chamber in the body sidewall 2116a that is enclosed by an openable seal plate 2250. A sealing gasket 2254 is provided at the interface between an annular rim 2252 of the sidewall 2116a and the seal plate 2250 to help provide an air-tight filter chamber 2248. In the illustrated example, the filter chamber 2248 extends over substantially the entire sidewall

2116a and overlies substantially all of the transverse cross sectional area of cyclone chamber **2162**, dirt collection chamber **2164** and suction motor **2111**.

A pre-motor filter **2256** is provided in the filter chamber **2248** to filter the air before it enters the suction motor inlet. The pre-motor filter **2256** is sized to cover substantially the entire area of the filter chamber **2248**, and overlies substantially all of the transverse cross sectional area of the cyclone chamber **2162**, dirt collection chamber **2164** and suction motor **2111**. In the illustrated example, the pre-motor filter **2256** comprises first and second pre-motor filters **2256a**, **2256b**. The filter chamber **2248** comprises an air inlet chamber **2258** on the upstream side of the pre-motor filter **2256**, and an air outlet chamber **2260** on the downstream side of the pre-motor filter **2256**. Air can travel from the air inlet chamber **2258** to the air outlet chamber **2260** by flowing through the pre-motor filter **2256**.

The air inlet chamber **2258** is fluidly connected to the vortex finder **2182** by an inlet conduit **2262** that extends through a first aperture **2264** in the pre-motor filter **2256**. The air outlet chamber **2260** is in fluid communication with the inlet **2246** of the suction motor **2111**. The pre-motor filter **2256** can be supported by a plurality of support ribs **2266** extending from the sidewall **2116a** into the air outlet chamber **2260**. Cutouts can be provided in the ribs to allow air to circulate within the air outlet chamber **2266** and flow toward the suction motor inlet **2246**.

In the illustrated example, the axle **2128a** for supporting the side wheel extends through the air filter chamber **2248**, a second aperture **2268** in the pre-motor filter **2256** and through an axel aperture **2270** in the seal plate **2250**. The axle aperture **2270** in the seal plate **2250** is configured to provide an air-tight seal against the axel **2128a**. Optionally, a sealing gasket can be provided at the interface between the seal plate **2250** and the axel **2128a**. In this configuration the pre-motor filter **2256** surrounds the axel **2128a**.

In the illustrated example, the seal plate **2250** is removable, when the side wheel **2120a** is detached, to allow a user to access the pre-motor filter **2256**. Alternatively, instead of being removable, the seal plate **2250** can be movably attached to the body **2112**, for example pivotally connected to the sidewall **2116a**, such that the seal plate **2250** can be opened without being completely detached from the body **2112**.

Preferably, the seal plate **2250** is transparent, or at least partially transparent. Providing a transparent seal plate **2250** may help facilitate visual inspection of the upstream side **2272** of the pre-motor filter **2256** while the seal plate **2250** is in place. When the seal plate **2250** is removed, the pre-motor filter **2256** may be removed, for example for cleaning or replacement.

A bleed valve is provided to supply clean air to the suction motor inlet. In the illustrated example a bleed valve air outlet **2278** is in fluid communication with the air outlet chamber **2260** and can introduce clean air into the air outlet chamber **2260** downstream from the pre-motor filter **2256**. Air introduced by the bleed valve can flow through the cutouts in the supporting ribs **2266**, as described above. The bleed valve may be a pressure sensitive valve that is opened when there is a blockage in the air flow path upstream from the suction motor **2111**. In the illustrated example, the bleed valve is parallel with the suction motor **2111**. A bleed valve inlet **2280** (see also FIG. 11) is provided toward the front of the body **2112**.

It will be appreciated that, in one embodiment, the enhanced dirt collection chamber construction may be used by itself without the enhanced filter chamber design. Alter-

nately, both the enhanced dirt collection chamber construction and the enhanced filter chamber design may be used concurrently as exemplified herein. It will also be appreciated that the cyclone chamber may be of any design and configuration. When either of the enhanced dirt collection chamber construction and/or the enhanced filter chamber design are used, the vacuum cleaner may be of any design and the dirt collection chamber may or may not be removably mounted from the vacuum cleaner.

Various apparatuses or methods are described above to provide an example of each claimed invention. No example described above limits any claimed invention and any claimed invention may cover processes or apparatuses that are not described above. The claimed inventions are not limited to apparatuses or processes having all of the features of any one apparatus or process described above or to features common to multiple or all of the apparatuses described above.

The invention claimed is:

1. A hand vacuum cleaner having a front end, a rear end, and comprising:

- (a) a main housing;
 - (b) a dirty fluid inlet;
 - (c) a cyclone bin assembly comprising a cyclone chamber downstream of the dirty fluid inlet, the cyclone chamber comprising a first end, a second end, a cyclone axis, a cyclone air inlet and a cyclone air outlet wherein the cyclone air outlet is located at the second end;
 - (d) a pre-motor filter comprising an upstream side and a downstream side, the pre-motor filter is positioned in a pre-motor filter housing having an openable cover, the cyclone axis extends through the pre-motor filter housing;
 - (e) a suction motor positioned in the main housing and located downstream of the pre-motor filter and rearward of the cyclone bin assembly;
 - (f) an air flow path extending from the pre-motor filter to the suction motor;
 - (g) a clean air outlet downstream of the suction motor; and,
 - (h) a handle connected to the hand vacuum cleaner at first and second locations, wherein the first location is at a position of the suction motor in the main housing and a first handle portion is connected at the first location, wherein a projection of the first handle portion extends through the suction motor,
- wherein the pre-motor filter housing is openable without moving the handle with respect to the cyclone chamber, and
- wherein the pre-motor filter housing cover is openable while the cyclone bin assembly is in fluid flow communication with the suction motor.

2. The hand vacuum cleaner of claim 1 wherein the suction motor comprises a fan and a motor and an upstream side of the fan is positioned proximate the cyclone inlet.

3. The hand vacuum cleaner of claim 1 wherein the downstream side of the pre-motor filter is spaced further from the cyclone chamber than the upstream side of the pre-motor filter.

4. The hand vacuum cleaner of claim 3 further comprising a downstream header on the downstream side of the pre-motor filter and the downstream header is opened when the openable cover is opened.

5. The hand vacuum cleaner of claim 1 wherein the upstream side of the pre-motor filter is spaced further from the cyclone chamber than the downstream side of the pre-motor filter.

15

6. The hand vacuum cleaner of claim 5 further comprising a conduit that is in flow communication with the air outlet of the cyclone chamber and extends through the pre-motor filter.

7. The hand vacuum cleaner of claim 5 further comprising an upstream header on the upstream side of the pre-motor filter and the upstream header is opened when the openable cover is opened.

8. The hand vacuum cleaner of claim 1 wherein each of the upstream and downstream sides of the pre-motor filter has a front end positioned proximate the front end and extending rearwardly, the pre-motor filter is positioned axially outwardly from the second end of the cyclone chamber and downstream of the cyclone chamber, the cyclone air outlet is positioned at a location spaced from the front end of the pre-motor filter.

9. The hand vacuum cleaner of claim 1 wherein the pre-motor filter is positioned axially outwardly from the second end of the cyclone chamber and downstream of the cyclone chamber, the pre-motor filter overlies at least a portion of the second end of the cyclone chamber.

10. The hand vacuum cleaner of claim 1 wherein the suction motor has a suction motor axis and when the hand vacuum cleaner is carried by the handle, the suction motor axis extends generally horizontally.

11. The hand vacuum cleaner of claim 10 wherein when the hand vacuum cleaner is carried by the handle, the cyclone axis extends generally horizontally.

12. The hand vacuum cleaner of claim 1 wherein when the hand vacuum cleaner is carried by the handle, the cyclone axis extends generally horizontally.

13. The hand vacuum cleaner of claim 1 wherein the pre-motor filter comprises a physical filter media.

14. A hand vacuum cleaner having a front end, a rear end and comprising:

- (a) a main housing;
- (b) a dirty fluid inlet;
- (c) a cyclone bin assembly comprising a cyclone chamber downstream of the dirty fluid inlet, the cyclone chamber comprising a first end, a second end, a cyclone air inlet, a cyclone axis, and a cyclone air outlet that is located at the second end;
- (d) a pre-motor filter comprising an upstream side and a downstream side, the pre-motor filter is positioned in a pre-motor filter housing having an openable cover;
- (e) a suction motor positioned in the main housing and located downstream of the pre-motor filter and rearward of the cyclone bin assembly;
- (f) an air flow path extending from the pre-motor filter to the suction motor;
- (g) a clean air outlet downstream of the suction motor; and,
- (h) a handle connected to the hand vacuum cleaner at first and second locations wherein the first location is at a

16

position of the suction motor in the main housing, the handle has a first handle portion provided at the first location, a projection of the first handle portion extends through the suction motor, and the pre-motor filter housing is openable without moving the handle with respect to the cyclone chamber;

wherein the pre-motor filter housing cover is openable while the cyclone chamber is in fluid flow communication with the suction motor, and

wherein the first and second locations are provided other than on the openable pre-motor filter housing cover.

15. The hand vacuum cleaner of claim 14 wherein the suction motor comprises a fan and a motor and an upstream side of the fan is positioned proximate the cyclone air inlet.

16. The hand vacuum cleaner of claim 14 wherein the downstream side of the pre-motor filter is spaced further from the cyclone chamber than the upstream side of the pre-motor filter.

17. The hand vacuum cleaner of claim 14 further comprising a downstream header on the downstream side of the pre-motor filter and the downstream header is opened when the openable cover is opened.

18. The hand vacuum cleaner of claim 14 wherein the upstream side of the pre-motor filter is spaced further from the cyclone chamber than the downstream side of the pre-motor filter.

19. The hand vacuum cleaner of claim 18 further comprising a conduit that is in flow communication with the cyclone air outlet and extends through the pre-motor filter.

20. The hand vacuum cleaner of claim 18 further comprising an upstream header on the upstream side of the pre-motor filter and the upstream header is opened when the openable cover is opened.

21. The hand vacuum cleaner of claim 14 wherein each of the upstream and downstream sides of the pre-motor filter has a front end positioned proximate the front end and extending rearwardly, the pre-motor filter is positioned axially outwardly from the second end of the cyclone chamber and downstream of the cyclone chamber, the cyclone air outlet is positioned at a location spaced from the front end of the pre-motor filter.

22. The hand vacuum cleaner of claim 14 wherein the suction motor has a suction motor axis and when the hand vacuum cleaner is carried by the handle, the suction motor axis extends generally horizontally.

23. The hand vacuum cleaner of claim 22 wherein when the hand vacuum cleaner is carried by the handle, the cyclone axis extends generally horizontally.

24. The hand vacuum cleaner of claim 14 wherein when the hand vacuum cleaner is carried by the handle, the cyclone axis extends generally horizontally.

25. The hand vacuum cleaner of claim 14 wherein the pre-motor filter comprises a physical filter media.

* * * * *