



US010624511B2

(12) **United States Patent**
Conrad

(10) **Patent No.:** **US 10,624,511 B2**

(45) **Date of Patent:** **Apr. 21, 2020**

(54) **SURFACE CLEANING APPARATUS**

(71) Applicant: **Omachron Intellectual Property Inc.,**
Hampton (CA)

(72) Inventor: **Wayne Ernest Conrad,** Hampton (CA)

(73) Assignee: **Omachron Intellectual Property Inc.,**
Hampton, Ontario (CA)

(*) Notice: Subject to any disclaimer, the term of this patent is extended or adjusted under 35 U.S.C. 154(b) by 177 days.

(21) Appl. No.: **15/660,807**

(22) Filed: **Jul. 26, 2017**

(65) **Prior Publication Data**

US 2018/0055300 A1 Mar. 1, 2018

Related U.S. Application Data

(63) Continuation of application No. 14/301,204, filed on Jun. 10, 2014, now Pat. No. 9,931,005, which is a
(Continued)

(51) **Int. Cl.**

A47L 5/22 (2006.01)
A47L 9/32 (2006.01)
A47L 9/00 (2006.01)
A47L 5/32 (2006.01)
A47L 7/00 (2006.01)

(Continued)

(52) **U.S. Cl.**

CPC *A47L 5/225* (2013.01); *A47L 9/0018* (2013.01); *A47L 9/327* (2013.01); *A47L 5/24* (2013.01); *A47L 5/28* (2013.01); *A47L 5/30* (2013.01); *A47L 5/32* (2013.01); *A47L 7/0095* (2013.01); *A47L 9/00* (2013.01); *A47L 9/0081* (2013.01); *A47L 9/02* (2013.01); *A47L 9/122* (2013.01); *A47L 9/16* (2013.01); *A47L 9/1691* (2013.01); *A47L 9/22* (2013.01); *A47L 9/246* (2013.01);

(Continued)

(58) **Field of Classification Search**

CPC *A47L 5/225*; *A47L 9/22*; *A47L 9/2863*; *A47L 9/327*; *A47L 9/0018*

USPC *15/328*, *329*, *331*, *334*, *335*
See application file for complete search history.

(56) **References Cited**

U.S. PATENT DOCUMENTS

2,071,975 A 2/1937 Holm-Hansen et al.
2,542,634 A 2/1951 Davis et al.

(Continued)

FOREIGN PATENT DOCUMENTS

CA 1218962 A1 3/1987
CA 2241644 A1 12/1998

(Continued)

OTHER PUBLICATIONS

English machine translation of JP4352065B2 published as of Oct. 28, 2009.

(Continued)

Primary Examiner — Bryan R Muller

(74) *Attorney, Agent, or Firm* — Philip C. Mendes da Costa; Bereskin & Parr LLP/S.E.N.C.R.L., s.r.l.

(57) **ABSTRACT**

A reconfigurable upright vacuum cleaner has a surface cleaning head with a pedestal member pivotally mounted thereto. An upper portion, which comprises a portable surface cleaning unit removably mounted thereto, is mounted to the pedestal member. An above floor cleaning wand is removably mounted to the pedestal member. The portable surface cleaning unit is securable to the pedestal member by a portable surface cleaning unit lock.

9 Claims, 85 Drawing Sheets

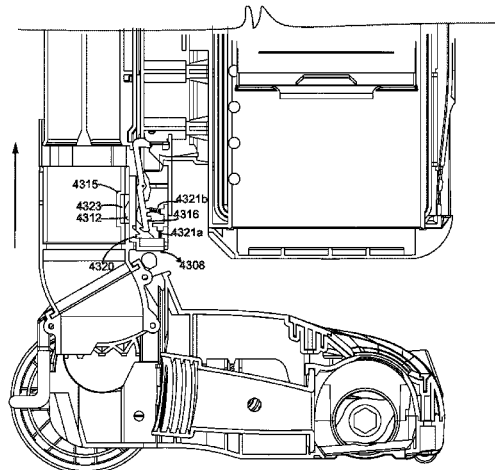

Related U.S. Application Data

continuation of application No. 13/781,324, filed on Feb. 28, 2013, now Pat. No. 9,456,721.

(51) **Int. Cl.**

- A47L 9/12 (2006.01)
- A47L 9/02 (2006.01)
- A47L 9/16 (2006.01)
- A47L 9/22 (2006.01)
- A47L 9/24 (2006.01)
- A47L 9/28 (2006.01)
- A47L 9/30 (2006.01)
- A47L 5/24 (2006.01)
- A47L 5/28 (2006.01)
- A47L 5/30 (2006.01)

(52) **U.S. Cl.**

- CPC A47L 9/248 (2013.01); A47L 9/2857 (2013.01); A47L 9/30 (2013.01); A47L 9/325 (2013.01)

(56)

References Cited

U.S. PATENT DOCUMENTS

2,632,524 A 3/1953 Senne et al.
 2,913,111 A 11/1959 Rogers et al.
 2,942,691 A 6/1960 Dillon et al.
 3,130,157 A 4/1964 Kelsall et al.
 3,200,568 A 8/1965 McNeil et al.
 3,310,828 A 3/1967 Clark et al.
 3,320,727 A 5/1967 Farley et al.
 3,356,334 A 12/1967 Domer et al.
 3,530,649 A 9/1970 Porsch et al.
 3,582,616 A 6/1971 Wrob
 3,822,533 A 7/1974 Oranje et al.
 3,898,068 A 8/1975 McNeil
 3,988,132 A 10/1976 Oranje
 3,988,133 A 10/1976 Schady
 4,187,088 A 2/1980 Hodgson et al.
 4,236,903 A 12/1980 Malmsten
 4,373,228 A 2/1983 Dyson et al.
 4,393,536 A 7/1983 Tapp
 4,443,910 A 4/1984 Fitzwater
 4,573,236 A 3/1986 Dyson
 4,635,315 A 1/1987 Kozak
 4,826,515 A 5/1989 Dyson et al.
 4,831,685 A 5/1989 Bosyj et al.
 5,054,157 A 10/1991 Werner et al.
 5,078,761 A 1/1992 Dyson et al.
 5,129,125 A 7/1992 Gamou et al.
 5,230,722 A 7/1993 Yonkers
 5,287,591 A 2/1994 Rench et al.
 5,309,600 A 5/1994 Weaver et al.
 5,309,601 A 5/1994 Hampton et al.
 5,524,321 A 6/1996 Weaver et al.
 5,715,566 A 2/1998 Weaver et al.
 5,836,047 A * 11/1998 Lee A47L 5/225
 15/328
 5,842,254 A 12/1998 Lee
 5,858,038 A 1/1999 Dyson et al.
 6,058,559 A * 5/2000 Yoshimi A47L 5/225
 15/323
 6,070,291 A 6/2000 Bair et al.
 6,081,961 A 7/2000 Wang
 6,210,469 B1 4/2001 Tokar
 6,221,134 B1 4/2001 Conrad et al.
 6,228,260 B1 5/2001 Conrad et al.
 6,231,645 B1 5/2001 Conrad et al.
 6,251,296 B1 6/2001 Conrad et al.
 6,295,692 B1 10/2001 Shideler
 6,406,505 B1 6/2002 Oh et al.
 6,440,197 B1 8/2002 Conrad et al.
 6,463,622 B2 10/2002 Wright et al.
 6,531,066 B1 3/2003 Saunders et al.

6,553,612 B1 4/2003 Dyson et al.
 6,560,818 B1 5/2003 Hasko
 6,581,239 B1 6/2003 Dyson et al.
 6,599,338 B2 7/2003 Oh et al.
 6,623,539 B2 9/2003 Lee et al.
 6,736,873 B2 5/2004 Conrad et al.
 6,746,500 B1 6/2004 Park et al.
 6,782,583 B2 8/2004 Oh
 6,782,585 B1 8/2004 Conrad et al.
 6,833,015 B2 12/2004 Oh et al.
 6,848,146 B2 2/2005 Wright et al.
 6,874,197 B1 4/2005 Conrad et al.
 6,901,625 B2 6/2005 Yang et al.
 6,902,596 B2 6/2005 Conrad et al.
 7,131,165 B2 11/2006 Wright et al.
 7,146,681 B2 12/2006 Wright et al.
 7,160,346 B2 1/2007 Park
 7,222,392 B2 5/2007 McCormick et al.
 7,222,393 B2 5/2007 Kaffenberger et al.
 7,377,008 B2* 5/2008 Park A47L 5/225
 15/323
 7,381,234 B2 6/2008 Oh
 7,386,916 B2 6/2008 Bone
 7,448,363 B1 11/2008 Rasmussen et al.
 7,481,860 B2 1/2009 Ivarsson
 7,485,164 B2 2/2009 Jeong et al.
 7,547,338 B2 6/2009 Kim et al.
 7,581,286 B2 9/2009 Choi
 7,594,296 B2 9/2009 Park
 7,604,675 B2 10/2009 Makarov et al.
 7,624,475 B2 12/2009 Choi
 7,645,309 B2 1/2010 Jeong et al.
 7,645,311 B2 1/2010 Oh et al.
 7,686,858 B2 3/2010 Oh
 7,882,592 B2 2/2011 Hwang et al.
 7,887,612 B2 2/2011 Conrad
 7,922,794 B2 4/2011 Morphey
 7,937,802 B2 5/2011 Yoo et al.
 7,979,953 B2 7/2011 Yoo
 7,996,956 B2 8/2011 Wood et al.
 8,032,981 B2 10/2011 Yoo
 8,032,983 B2 10/2011 Griffith et al.
 8,082,623 B2 12/2011 Scott
 8,100,999 B2 1/2012 Ashbee et al.
 8,127,398 B2 3/2012 Conrad
 8,166,607 B2 5/2012 Conrad
 8,191,203 B2 6/2012 Yoo
 8,468,646 B2 6/2013 Yoo
 8,484,799 B2 7/2013 Conrad
 8,528,160 B2 9/2013 Conrad
 8,544,143 B2 10/2013 Hwang et al.
 9,138,114 B2* 9/2015 Conrad A47L 5/225
 9,314,138 B2 4/2016 Conrad
 9,364,127 B2 6/2016 Conrad
 2002/0011053 A1 1/2002 Oh
 2002/0062531 A1 5/2002 Oh
 2002/0134059 A1 9/2002 Oh
 2002/0162188 A1 11/2002 Harmen
 2002/0178535 A1 12/2002 Oh et al.
 2002/0178698 A1 12/2002 Oh et al.
 2002/0178699 A1 12/2002 Oh
 2003/0046910 A1 3/2003 Lee et al.
 2003/0066273 A1 4/2003 Choi et al.
 2003/0158238 A1 8/2003 Hale et al.
 2003/0159411 A1 8/2003 Hansen et al.
 2004/0010885 A1 1/2004 Hitzelberger et al.
 2004/0025285 A1 2/2004 McCormick et al.
 2004/0112022 A1 6/2004 Vuijk
 2004/0163201 A1 8/2004 Murphy et al.
 2004/0261213 A1 12/2004 Park et al.
 2005/0022338 A1 2/2005 Muhlenkamp
 2005/0198769 A1 9/2005 Lee et al.
 2005/0252179 A1 11/2005 Oh et al.
 2006/0037172 A1 2/2006 Choi
 2006/0042038 A1 3/2006 Arnold et al.
 2006/0042206 A1 3/2006 Arnold et al.
 2006/0080947 A1 4/2006 Lee et al.
 2006/0123590 A1 6/2006 Fester et al.
 2006/0137304 A1 6/2006 Jeong et al.

(56)

References Cited

U.S. PATENT DOCUMENTS

2006/0137305 A1 6/2006 Jung
 2006/0137306 A1 6/2006 Jeong et al.
 2006/0137309 A1 6/2006 Jeong et al.
 2006/0137314 A1 6/2006 Conrad et al.
 2006/0156699 A1 7/2006 Kim
 2006/0162298 A1 7/2006 Oh et al.
 2006/0162299 A1 7/2006 North
 2006/0168922 A1 8/2006 Oh
 2006/0168923 A1 8/2006 Lee et al.
 2006/0207055 A1 9/2006 Ivarsson et al.
 2006/0207231 A1 9/2006 Arnold
 2006/0230715 A1 10/2006 Oh et al.
 2006/0230723 A1 10/2006 Kim et al.
 2006/0230724 A1 10/2006 Han et al.
 2006/0230726 A1 10/2006 Oh et al.
 2006/0236663 A1 10/2006 Oh
 2006/0278081 A1 12/2006 Han et al.
 2007/0012002 A1 1/2007 Oh et al.
 2007/0012003 A1 1/2007 Oh et al.
 2007/0033765 A1 2/2007 Walker et al.
 2007/0039120 A1 2/2007 Choi
 2007/0067944 A1 3/2007 Kitamura et al.
 2007/0079473 A1 4/2007 Min et al.
 2007/0079584 A1 4/2007 Kim et al.
 2007/0079585 A1 4/2007 Oh et al.
 2007/0079587 A1 4/2007 Kim
 2007/0084161 A1 4/2007 Yoo
 2007/0095028 A1 5/2007 Kim et al.
 2007/0095029 A1 5/2007 Min et al.
 2007/0226947 A1 10/2007 Kang
 2007/0251048 A1 11/2007 Choi
 2007/0271724 A1 11/2007 Hakan et al.
 2007/0289085 A1 12/2007 Yoo
 2007/0289089 A1 12/2007 Yacobi
 2007/0289264 A1 12/2007 Oh
 2008/0047091 A1 2/2008 Nguyen
 2008/0083085 A1 4/2008 Genn
 2008/0134462 A1 6/2008 Jansen et al.
 2008/0172821 A1 7/2008 Kang et al.
 2008/0172995 A1 7/2008 Conrad
 2008/0178416 A1 7/2008 Conrad
 2008/0178420 A1 7/2008 Conrad
 2009/0031522 A1* 2/2009 Yoo A47L 5/28
 15/327.1
 2009/0044371 A1* 2/2009 Yoo A47L 5/225
 15/327.2
 2009/0144928 A1* 6/2009 Yoo A47L 5/225
 15/327.1
 2009/0144929 A1* 6/2009 Yoo A47L 5/225
 15/327.5
 2009/0178229 A1* 7/2009 Yoo A47L 5/225
 15/328
 2010/0005611 A1 1/2010 Hong et al.
 2010/0071152 A1 3/2010 Cho et al.
 2010/0071153 A1 3/2010 Genn
 2010/0095476 A1 4/2010 Kim et al.
 2010/0139030 A1 6/2010 Yoo
 2010/0139033 A1 6/2010 Makarov et al.
 2010/0162515 A1 7/2010 Stephens
 2010/0175217 A1 7/2010 Conrad
 2010/0175219 A1 7/2010 Soen et al.
 2010/0229336 A1* 9/2010 Conrad A47L 5/225
 15/415.1
 2010/0229338 A1 9/2010 Conrad
 2010/0242222 A1 9/2010 Conrad
 2011/0023262 A1 2/2011 Conrad
 2011/0219567 A1 9/2011 Conrad
 2011/0219573 A1 9/2011 Conrad
 2011/0314629 A1 12/2011 Conrad
 2012/0000030 A1 1/2012 Conrad
 2012/0159734 A1 6/2012 Fujiwara
 2012/0222245 A1 9/2012 Conrad
 2012/0222251 A1 9/2012 Conrad
 2012/0222262 A1 9/2012 Conrad

2012/0272472 A1 11/2012 Conrad
 2013/0091812 A1 4/2013 Smith
 2013/0091813 A1 4/2013 Smith
 2013/0104335 A1 5/2013 Conrad
 2014/0237755 A1 8/2014 Conrad
 2014/0237756 A1 8/2014 Conrad
 2015/0007409 A1 1/2015 Conrad

FOREIGN PATENT DOCUMENTS

CA 2241644 C 12/2007
 CA 2675723 A1 6/2008
 CA 2677530 A1 6/2008
 CA 2658005 A1 9/2010
 CA 2658381 A1 9/2010
 CA 2658651 A1 9/2010
 CA 2659212 A1 9/2010
 CA 2674056 A1 9/2010
 CA 2674761 A1 9/2010
 CA 2678119 A1 9/2010
 CA 2755305 A1 9/2010
 CA 2755307 A1 9/2010
 CA 2674758 A1 1/2011
 CA 2730689 A1 9/2011
 CA 2574291 C 8/2013
 CA 2677530 C 1/2014
 CA 2755305 C 7/2014
 CA 2755307 C 7/2014
 CA 2674761 C 10/2016
 CA 2674758 C 2/2017
 CN 1336154 A 2/2002
 CN 2524655 Y 12/2002
 CN 2534954 Y 2/2003
 CN 1434688 A 8/2003
 CN 1765283 A 5/2006
 CN 1806741 A 7/2006
 CN 1875846 A 12/2006
 CN 1875855 A 12/2006
 CN 101014274 A 8/2007
 CN 101108081 A 1/2008
 CN 101108106 A 1/2008
 CN 101108110 A 1/2008
 CN 201101488 Y 8/2008
 CN 101357051 A 2/2009
 CN 201290642 Y 8/2009
 CN 101657133 A 2/2010
 CN 101631484 B 11/2012
 CN 202699035 U 1/2013
 DE 3734355 C2 6/1989
 DE 69309275 T3 6/2002
 DE 10056935 C2 1/2003
 DE 10110581 C2 11/2003
 DE 69907201 T2 2/2004
 DE 10360002 A1 12/2004
 DE 60105004 T2 8/2005
 DE 60201666 T2 6/2006
 DE 60211663 T2 5/2007
 DE 102004028678 B4 9/2007
 DE 102007011457 A1 10/2007
 DE 60033986 T2 11/2007
 DE 102004055192 B4 11/2007
 DE 102004028677 B4 1/2008
 DE 102005008278 B2 3/2008
 DE 112006003479 T5 12/2008
 DE 112007001314 T5 4/2009
 DE 602006000726 T2 4/2009
 DE 112010001135 T5 8/2012
 DE 112011104642 T5 10/2013
 DE 112012000251 T5 10/2013
 DE 112011104642 T8 12/2013
 EP 489468 A1 6/1992
 EP 887040 A1 12/1998
 EP 1674009 A2 6/2006
 EP 1771104 B1 9/2008
 EP 966912 B1 3/2010
 EP 2049000 B1 6/2011
 EP 2201875 B1 4/2013
 EP 1629758 B1 10/2013
 FR 2812531 B1 11/2004

(56)

References Cited

OTHER PUBLICATIONS

FOREIGN PATENT DOCUMENTS

GB	2163703	B	1/1988	English machine translation of JP2000140533A published as of May 23, 2000.
GB	2365324	B	7/2002	English machine translation of JP2003135335A published as of May 13, 2003.
GB	2458243	A	9/2009	English machine translation of JP2003245232A published as of Sep. 2, 2003.
GB	2465781	A	6/2010	English machine Translation of JP2004121722 published as of Apr. 22, 2004.
GB	2458243	B	4/2012	English machine translation of JP2005040246 published as of Feb. 17, 2005.
GB	2465781	B	10/2012	English machine translation of JP2005087508 Published as of Apr. 7, 2005.
JP	2000140533	A	5/2000	English machine translation of JP2006272019 published as of Oct. 12, 2006.
JP	2003135335	A	5/2003	English machine translation of JP2009261501 published as of Nov. 12, 2009.
JP	2003245232	A	9/2003	English machine translation of JP2010081968 published as of Apr. 15, 2010.
JP	2004121722	A	4/2004	English machine translation of JP2010227287 published as of Oct. 14, 2010.
JP	2005040246	A	2/2005	English machine translation of KR1020010045598 Published as of Jun. 5, 2001.
JP	2005087508	A	4/2005	English machine translation of KR1020020067489 Published as of Aug. 22, 2002.
JP	2006272019	A	10/2006	English machine translation of KR1020020085478 Published as of Nov. 16, 2002.
JP	4352065	B2	10/2009	English machine translation of KR1020040050174 Published as of Jun. 16, 2004.
JP	2009261501	A	11/2009	English machine translation of KR1020050013696 Published as of Feb. 5, 2005.
JP	2010081968	A	4/2010	English machine translation of KR1020050054551 Published as of Jun. 10, 2005.
JP	2010227287	A	10/2010	English machine translation of KR1020050091821 Published as of Sep. 15, 2005.
KR	1020010045598	A	6/2001	English machine translation of KR1020050091824 Published as of Sep. 15, 2005.
KR	1020020067489	A	8/2002	English machine translation of KR1020050091826 Published as of Sep. 15, 2005.
KR	1020020085478	A	11/2002	English machine translation of KR1020050091829 Published as of Sep. 15, 2005.
KR	1020040050174	A	6/2004	English machine translation of KR1020050091830 Published as of Sep. 15, 2005.
KR	1020050013696	A	2/2005	English machine translation of KR1020050091833 Published as of Sep. 15, 2005.
KR	1020050054551	A	6/2005	English machine translation of KR1020050091834 Published as of Sep. 15, 2005.
KR	1020050091821	A	9/2005	English machine translation of KR1020050091835 Published as of Sep. 15, 2005.
KR	1020050091824	A	9/2005	English machine translation of KR1020050091836 Published as of Sep. 15, 2005.
KR	1020050091826	A	9/2005	English machine translation of KR1020050091837 Published as of Sep. 15, 2005.
KR	1020050091829	A	9/2005	English machine translation of KR1020050091838 Published as of Sep. 15, 2005.
KR	1020050091830	A	9/2005	English machine translation of KR1020050103343 Published as of Oct. 31, 2005.
KR	1020050091833	A	9/2005	English machine translation of KR1020050104614 Published as of Nov. 3, 2005.
KR	1020050091834	A	9/2005	English machine translation of KR1020050104614 Published as of Nov. 3, 2005.
KR	1020050091835	A	9/2005	English machine translation of KR1020050108623 Published as of Nov. 17, 2005.
KR	1020050091836	A	9/2005	English machine translation of KR1020060008365 Published as of Jan. 26, 2006.
KR	1020050091837	A	9/2005	English machine translation of KR1020060017131 Published as of Feb. 23, 2006.
KR	1020050091838	A	9/2005	English machine translation of KR1020060018004 Published as of Feb. 28, 2006.
KR	1020050103343	A	10/2005	English machine translation of KR1020060081229 Published as of Jul. 12, 2006.
KR	1020050104613	A	11/2005	English machine translation of KR1020060112420 Published as of Nov. 1, 2006.
KR	1020050104614	A	11/2005	
KR	1020050108623	A	11/2005	
KR	1020060008365	A	1/2006	
KR	1020060017131	A	2/2006	
KR	1020060018004	A	2/2006	
KR	1020060081229	A	7/2006	
KR	1020060112420	A	11/2006	
KR	1020060116293	A	11/2006	
KR	1020060118795	A	11/2006	
KR	1020060118800	A	11/2006	
KR	1020060118801	A	11/2006	
KR	1020060118802	A	11/2006	
KR	1020060118803	A	11/2006	
KR	1020060119587	A	11/2006	
KR	1020060122249	A	11/2006	
KR	1020060122521	A	11/2006	
KR	1020060125952	A	12/2006	
KR	1020060125954	A	12/2006	
KR	1020070017441	A	2/2007	
KR	1020100084127	A	7/2010	
WO	9619294	A1	6/1996	
WO	2005089618	A2	9/2005	
WO	2005089618	A3	2/2006	
WO	2006026414	A3	8/2007	
WO	2007104138	A1	9/2007	
WO	2007084699	A3	2/2008	
WO	2008017802	A1	2/2008	
WO	2008070966	A1	6/2008	
WO	2008070980	A1	6/2008	
WO	2008135708	A1	11/2008	
WO	2007078546	A3	2/2009	
WO	2009026709	A1	3/2009	
WO	2010102396	A1	9/2010	
WO	2010102410	A1	9/2010	
WO	2010102411	A1	9/2010	
WO	2014131106	A1	9/2014	

(56)

References Cited

OTHER PUBLICATIONS

English machine translation of KR1020060116293 Published as of Nov. 15, 2006.
English machine translation of KR1020060118795 Published as of Nov. 24, 2006.
English machine translation of KR1020060118800 Published as of Nov. 24, 2006.
English machine translation of KR1020060118801 Published as of Nov. 24, 2006.
English machine translation of KR1020060118802 Published as of Nov. 24, 2006.
English machine translation of KR1020060118803 Published as of Nov. 24, 2006.
English machine translation of KR1020060119587 Published as of Nov. 24, 2006.
English machine translation of KR1020060122249 Published as of Nov. 30, 2006.
English machine translation of KR1020060122521 Published as of Nov. 30, 2006.
English machine translation of KR1020060125952 Published as of Dec. 7, 2006.
English machine translation of KR1020060125954 Published as of Dec. 7, 2006.
English machine translation of KR1020070017441 Published as of Feb. 9, 2007.
English machine translation of KR1020100084127 Published as of Jul. 23, 2010.
English machine translation of DE602006000726 Published as of Apr. 16, 2009.
English machine translation of DE112012000251 Published as of Oct. 17, 2013.
English machine translation of DE112011104642 Published as of Oct. 2, 2013.
English machine translation of DE112010001135 Published as of Aug. 2, 2012.
English machine translation of DE112007001314 Published as of Apr. 23, 2009.
English machine translation of DE112006003479 Published as of Dec. 18, 2008.
English machine translation of DE102007011457 Published as of Oct. 25, 2007.
English machine translation of DE102004055192 Published as of Nov. 15, 2007.
English machine translation of DE102004028678 Published as of Sep. 6, 2007.
English machine translation of DE102004028677 Published as of Jan. 10, 2008.
English machine translation of CN202699035 Published as of Jan. 30, 2013.
English machine translation of CN201290642 Published as of Aug. 19, 2009.
English machine translation of CN201101488 Published as of Aug. 20, 2008.
English machine translation of CN101657133 Published as of Feb. 24, 2010.
English machine translation of CN101631484 Published as of Nov. 28, 2012.
English machine translation of CN101357051 Published as of Feb. 4, 2009.
English machine translation of CN101108110 Published as of Jan. 23, 2008.
English machine translation of CN101108106 Published as of Jan. 23, 2008.
English machine translation of CN101108081 Published as of Jan. 23, 2008.
English machine translation of CN101014274 Published as of Aug. 8, 2007.

English machine translation of DE69907201 Published as of Feb. 5, 2004.
English machine translation of DE69309275 Published as of Jun. 27, 2002.
English machine translation of DE60211663 Published as of May 10, 2007.
English machine translation of DE60201666 Published as of Jun. 1, 2006.
English machine translation of DE60105004 Published as of Aug. 18, 2005.
English machine translation of DE60033986 Published as of Nov. 29, 2007.
English machine translation of DE10360002 Published as of Dec. 16, 2004.
English machine translation of DE10110581 Published as of Nov. 13, 2003.
English machine translation of DE10056935 Published as of Jan. 16, 2003.
English machine translation of DE3734355 Published as of Jun. 29, 1989.
English machine translation of FR2812531 Published as of Nov. 5, 2004.
English machine translation of CN2534954 Published as of Feb. 12, 2003.
English machine translation of CN2524655 Published as of Dec. 11, 2002.
English machine translation of CN1875855 Published as of Dec. 13, 2006.
English machine translation of CN1875846 Published as of Dec. 13, 2006.
English machine translation of CN1806741 Published as of Jul. 26, 2006.
English machine translation of CN1765283 Published as of Jul. 26, 2006.
English machine translation of CN1434688 Published as of Aug. 6, 2003.
English machine translation of CN1336154 Published as of Feb. 20, 2002.
International Preliminary Report on Patentability, received in connection to PCT/CA2014/000135, dated Sep. 11, 2015.
International Search Report received in connection to PCT/CA2014/000135, dated May 12, 2014.
International Preliminary Report on Patentability, received in connection to PCT/CA2007/0003805, dated Jul. 24, 2007.
Supplementary European Search Report, dated Jun. 16, 2009, as received on the corresponding EP application No. 07719394.4.
International Search Report received on the corresponding international application No. PCT/CA2010/000366 dated Jun. 16, 2010.
International Search Report received on the corresponding international application No. PCT/CA2010/000342 dated Jun. 17, 2010.
Office Action received in connection to Chinese Patent Application No. 200880113799.8 dated Jul. 23, 2012.
English translation of the Chinese Office Action, received in connection to Chinese Patent Application No. 200880113799.8, dated Nov. 9, 2011.
English machine translation of DE102005008278 published as of Mar. 27, 2008.
English machine translation of JP2005040246, published on Feb. 17, 2005.
English machine translation of JP2009261501; published on Nov. 12, 2009.
English machine translation of DE112011104642T5, published on Oct. 2, 2013.
English machine translation of CN201101488Y, published on Aug. 20, 2008.
English machine translation of CN101357051, published on Feb. 4, 2009.

* cited by examiner

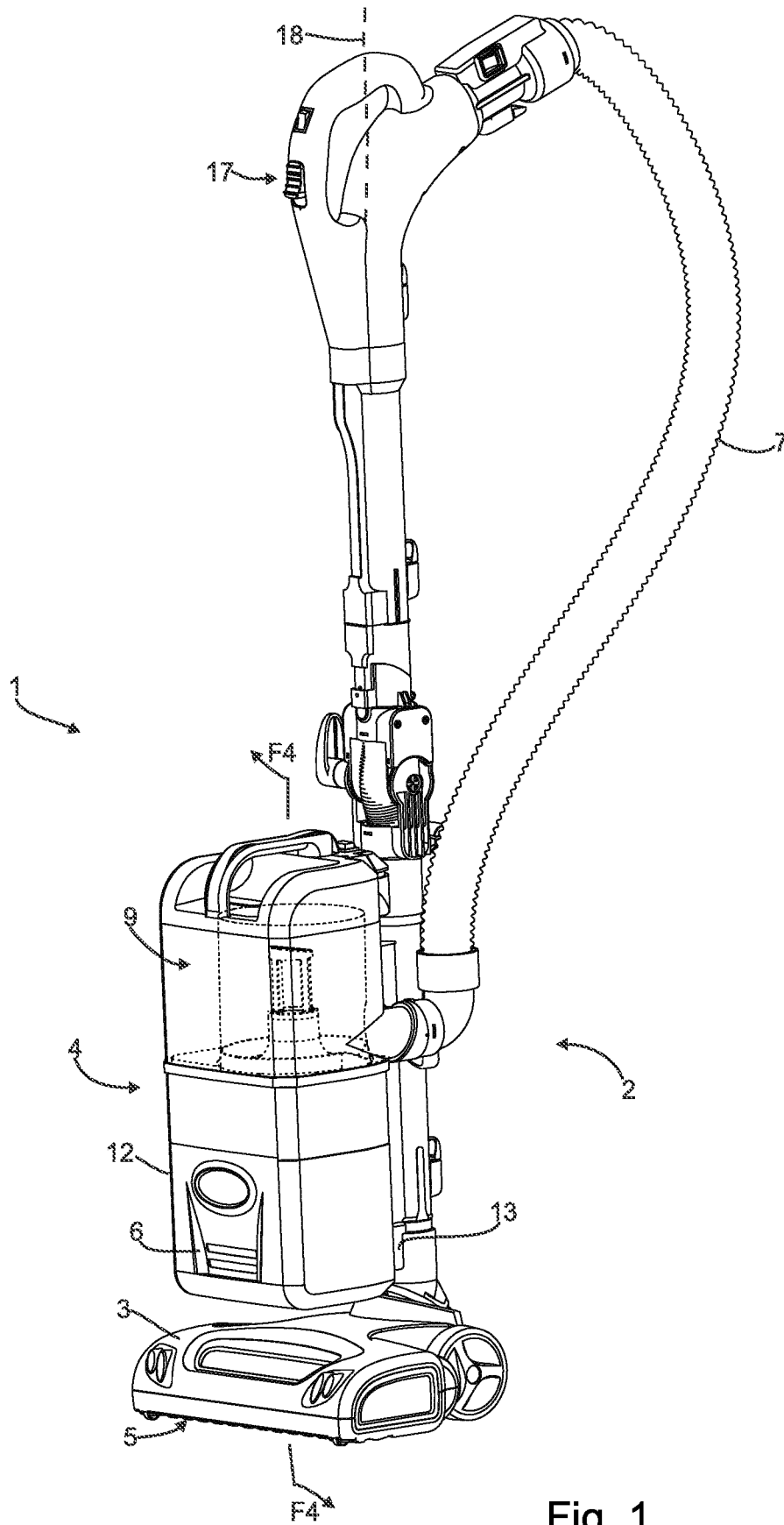

Fig. 1

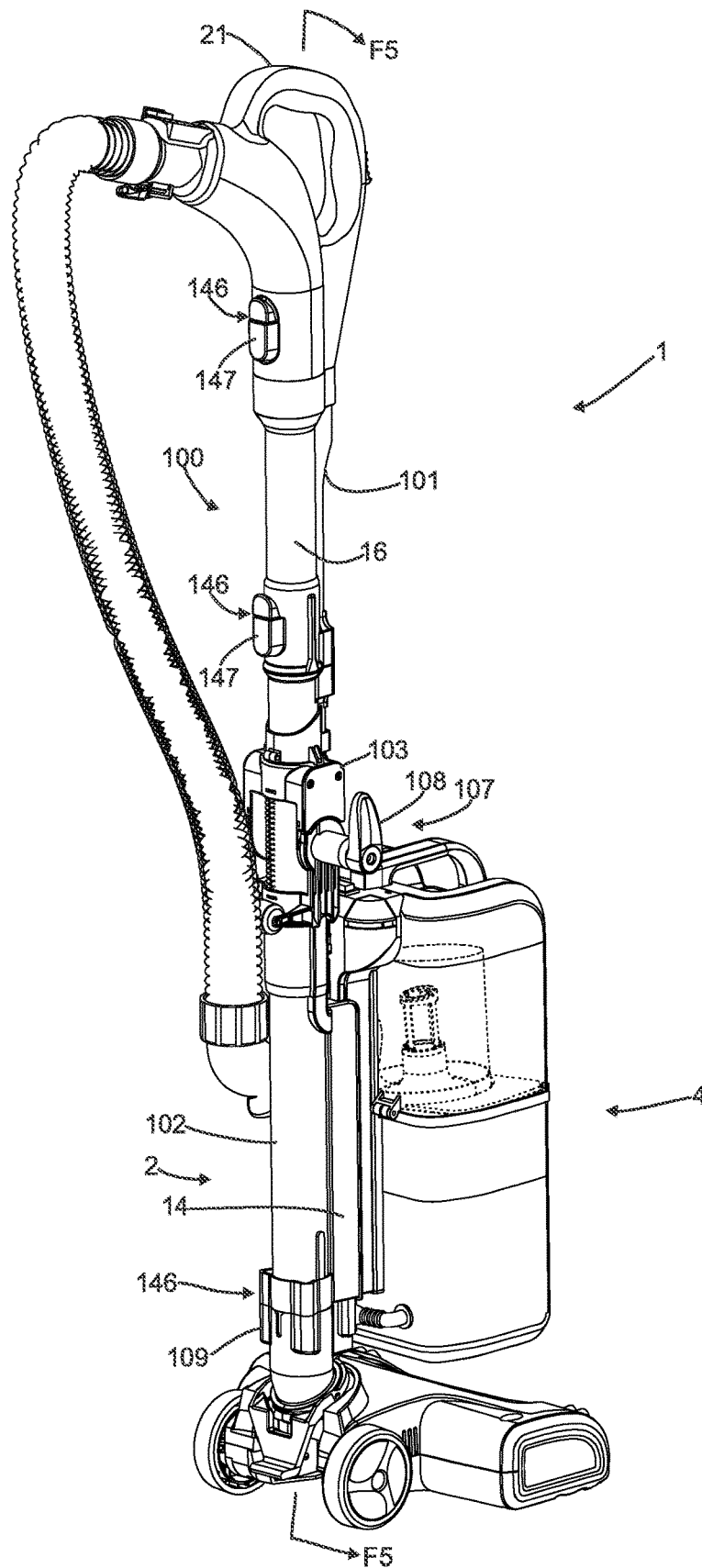

Fig. 2

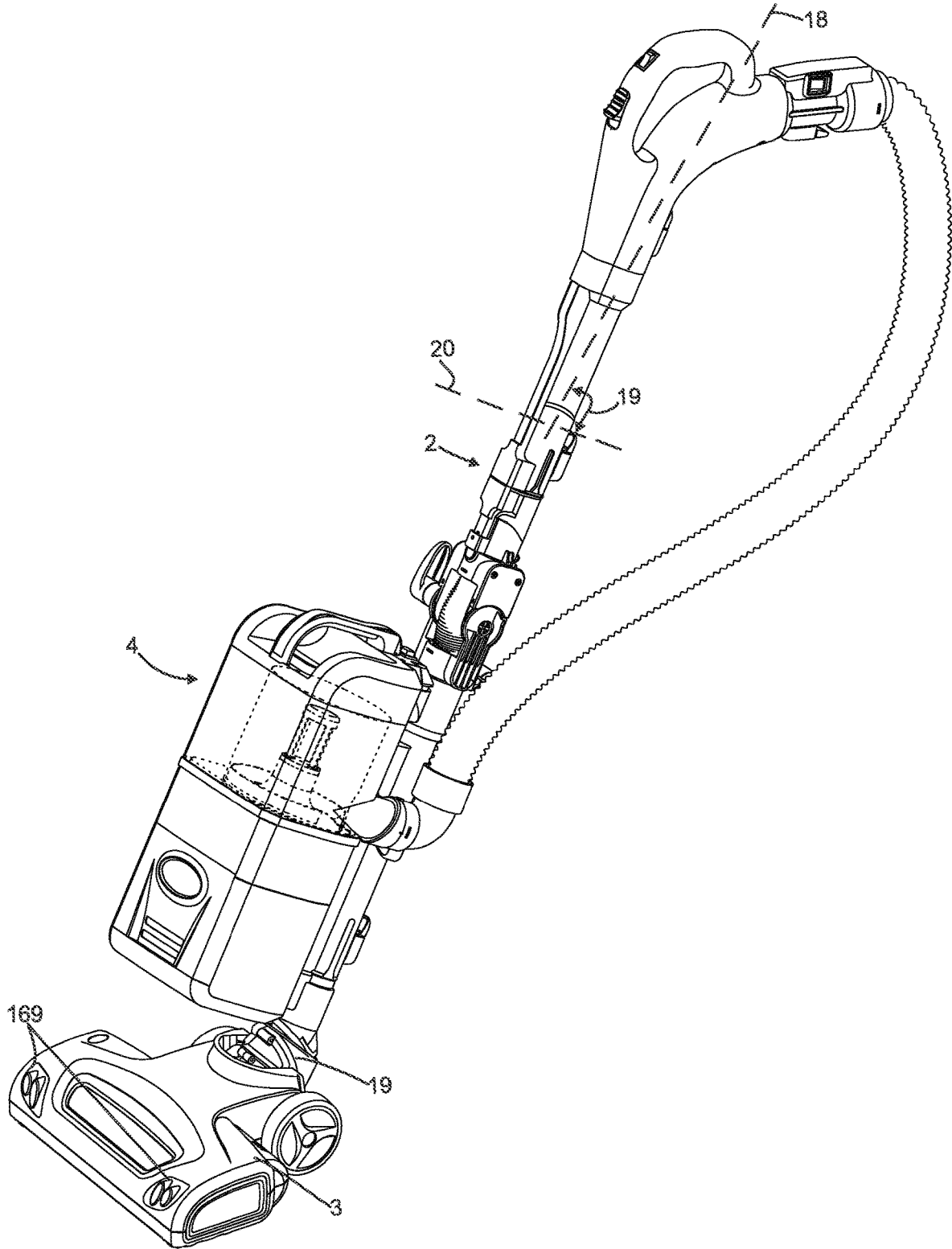

Fig. 3

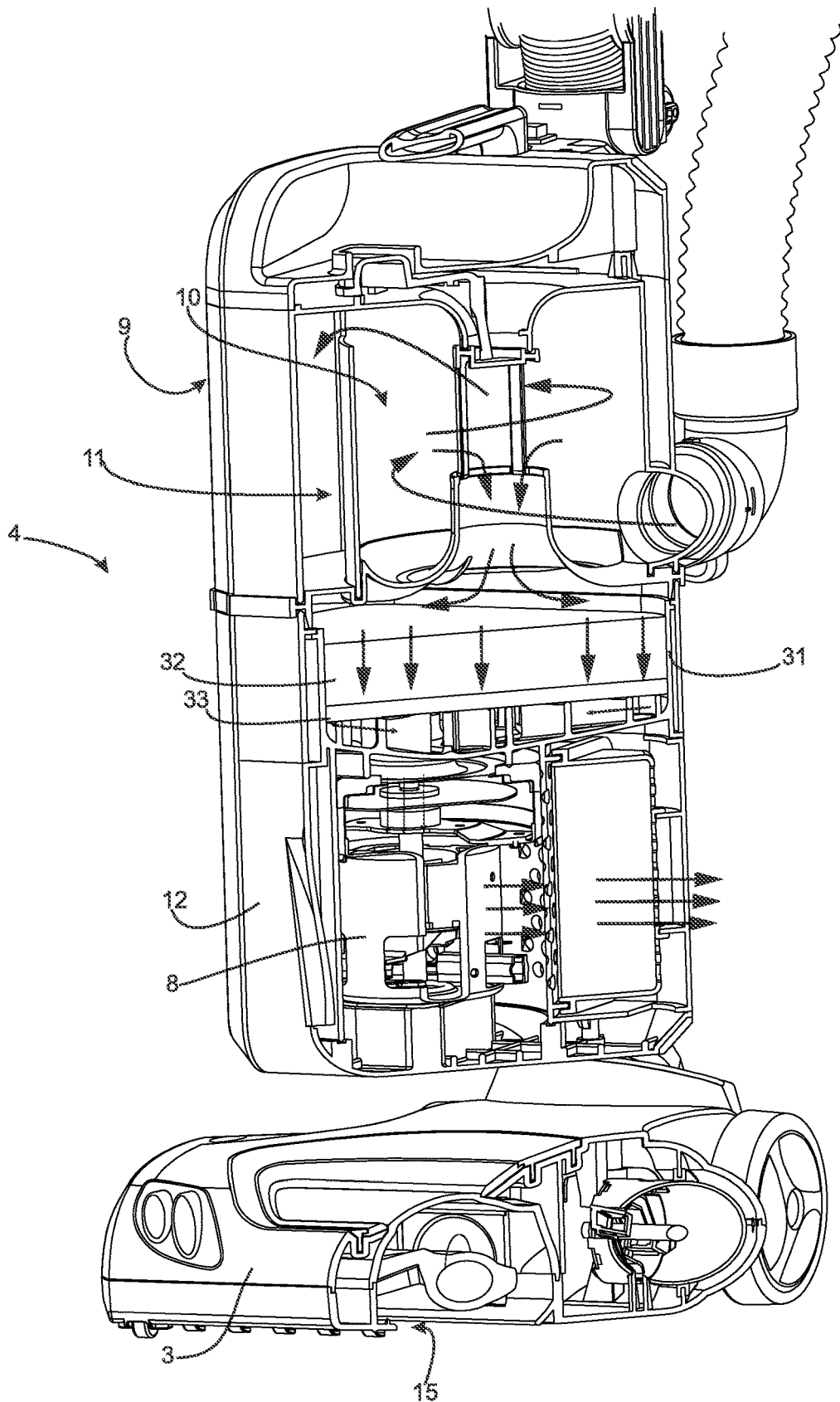

Fig. 4

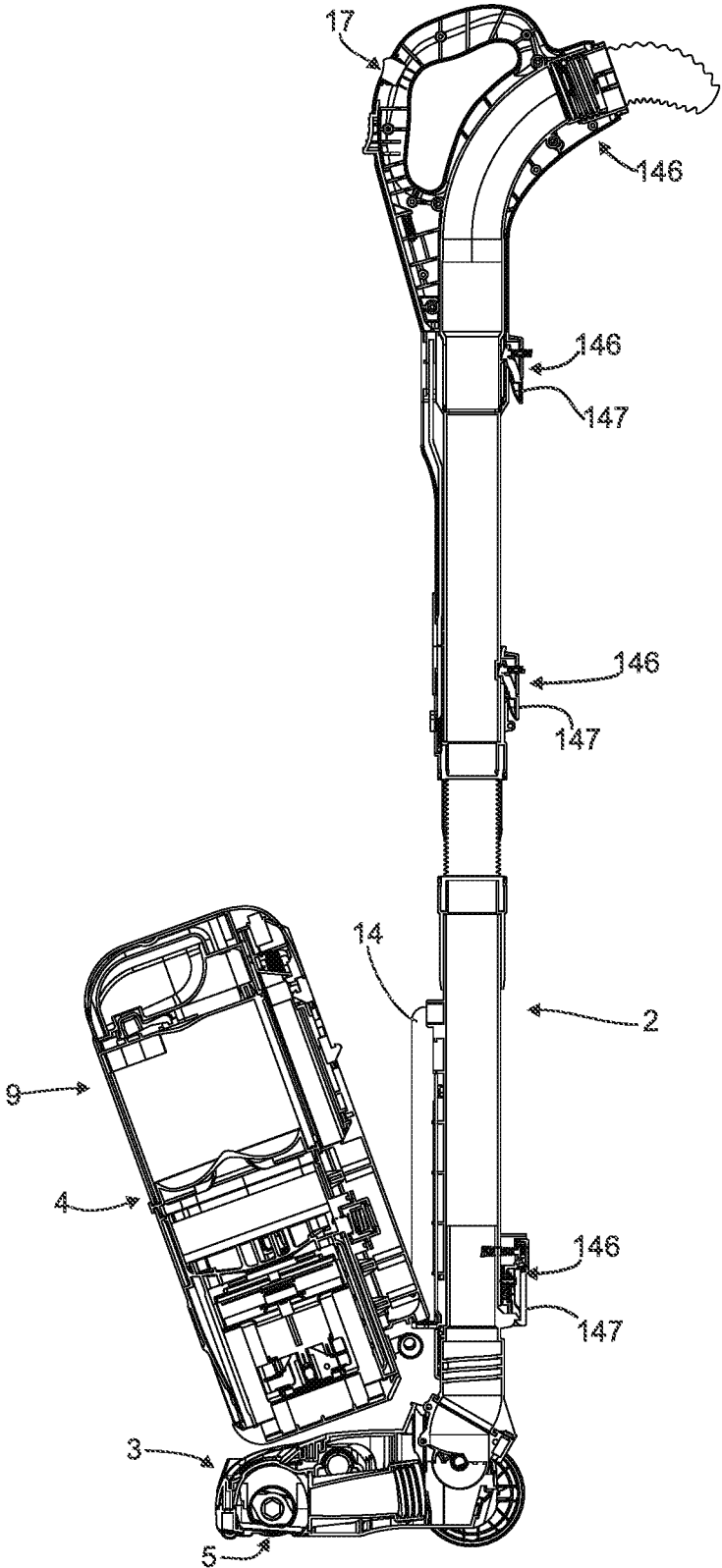

Fig. 5

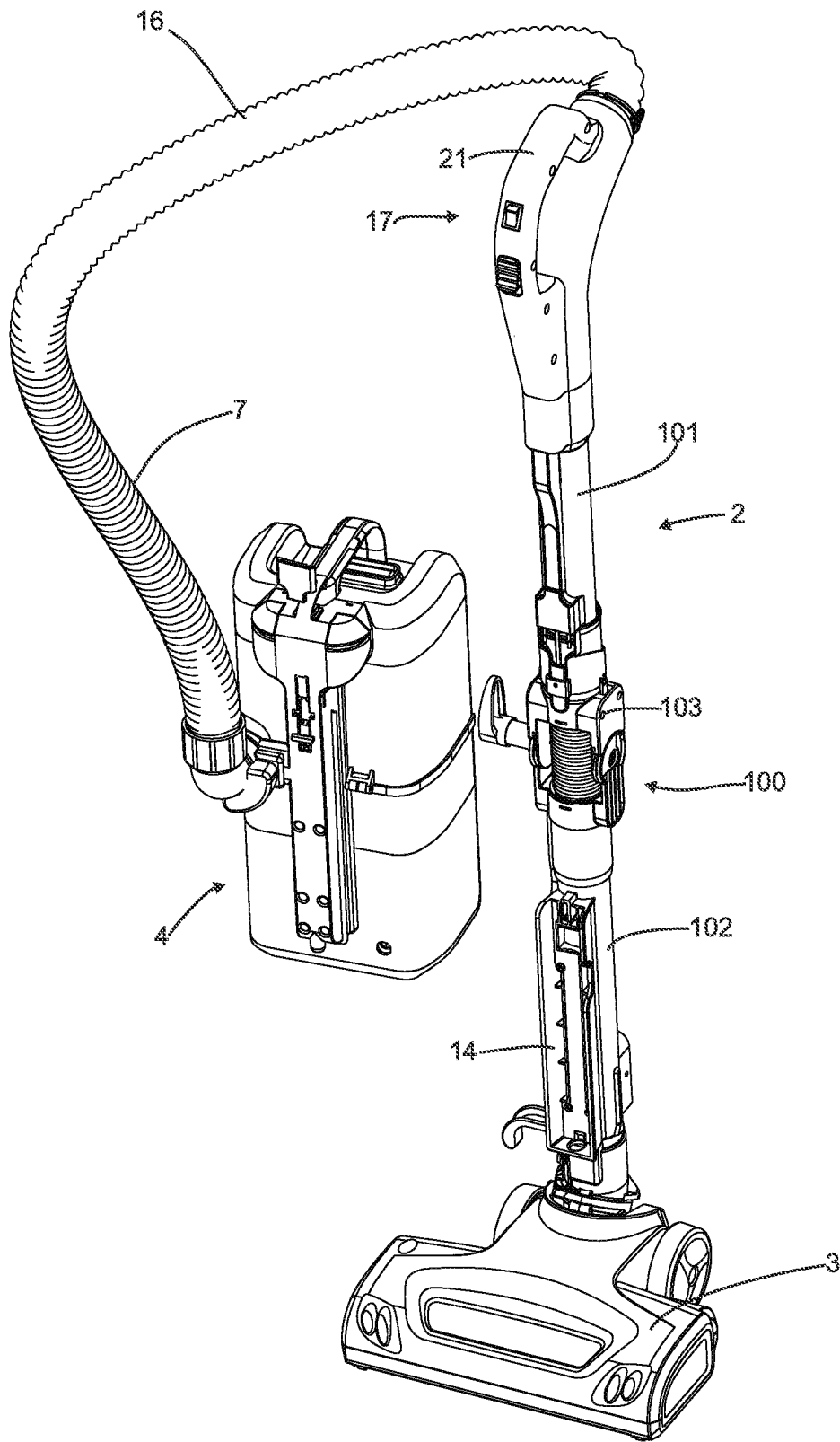

Fig. 6

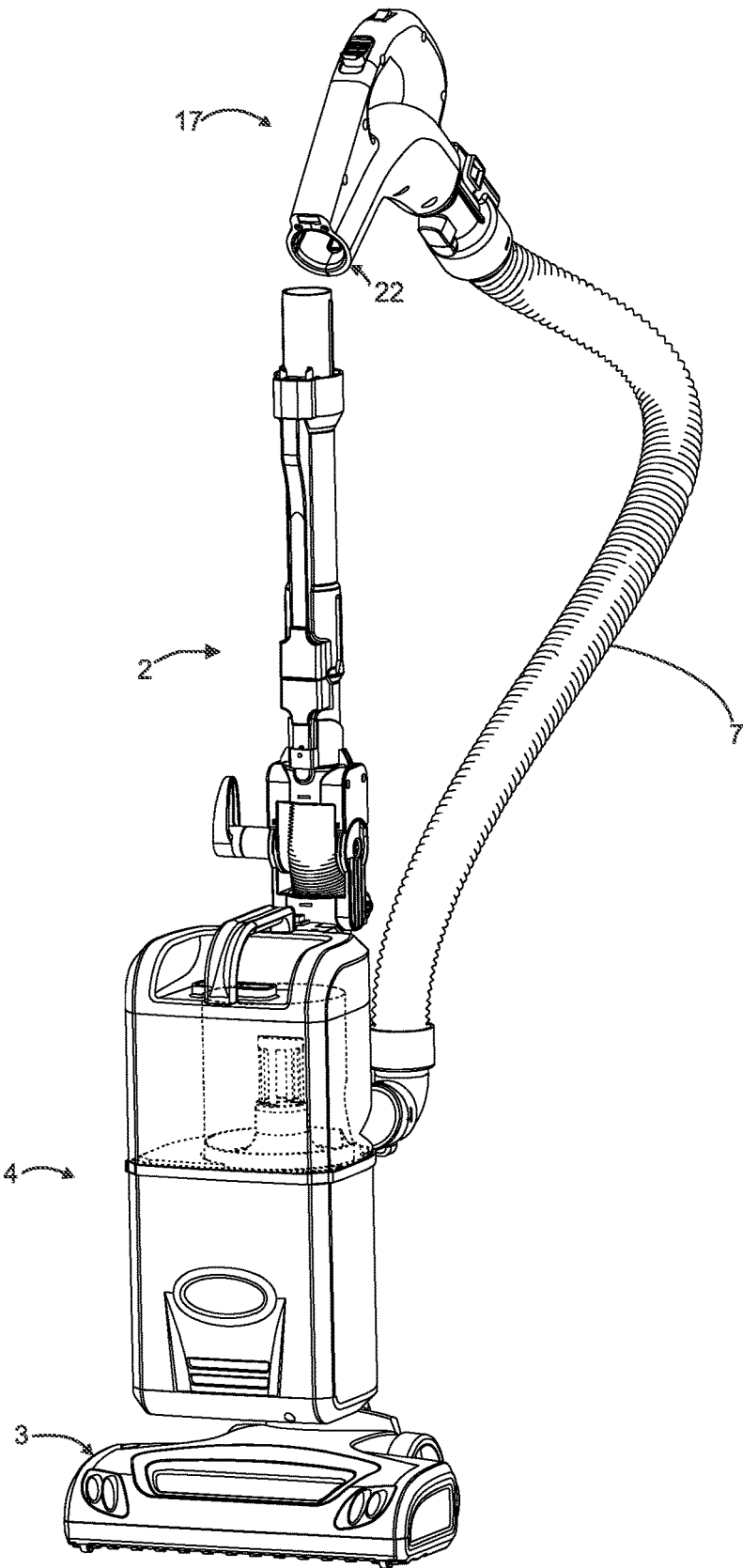

Fig. 7

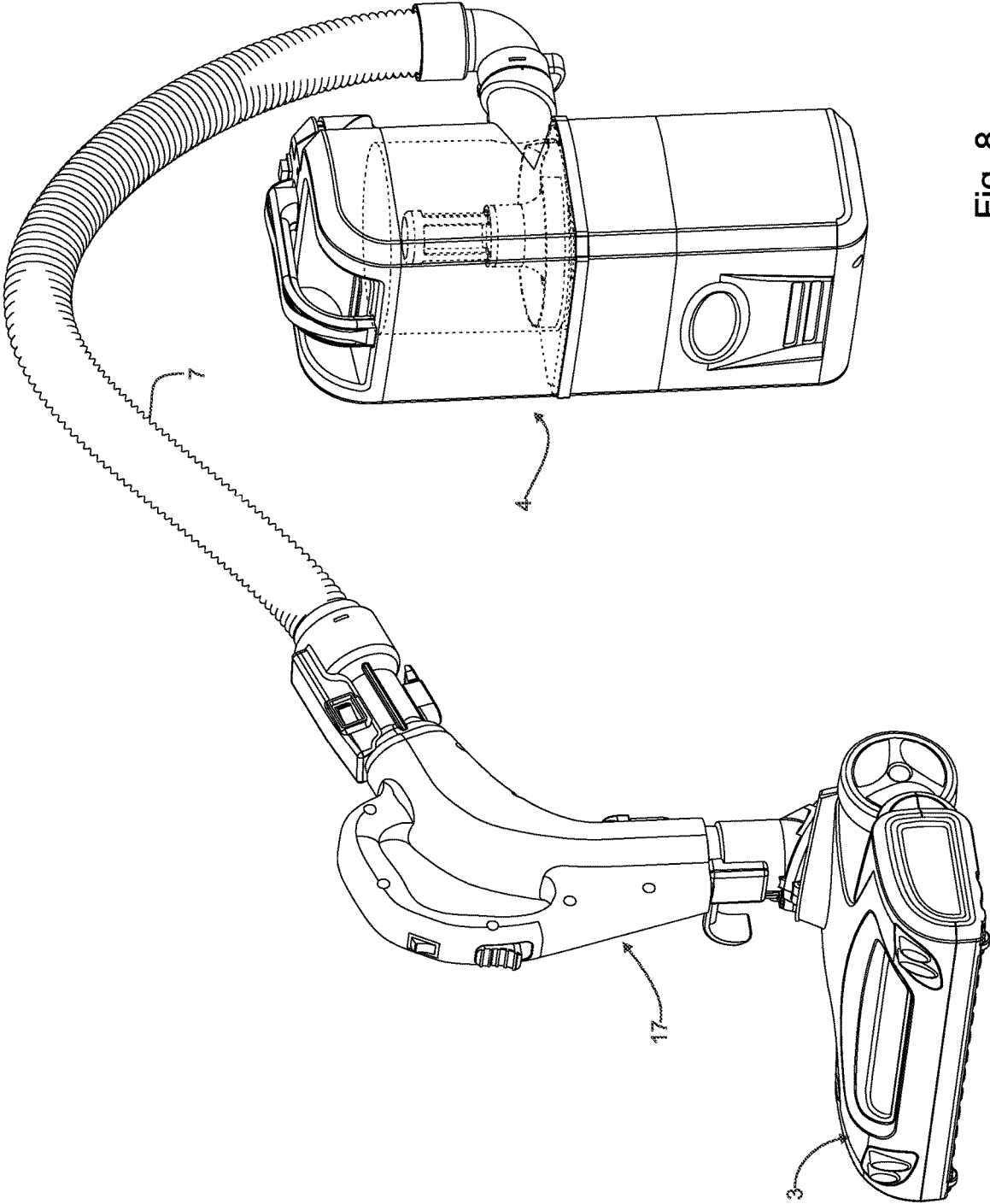

Fig. 8

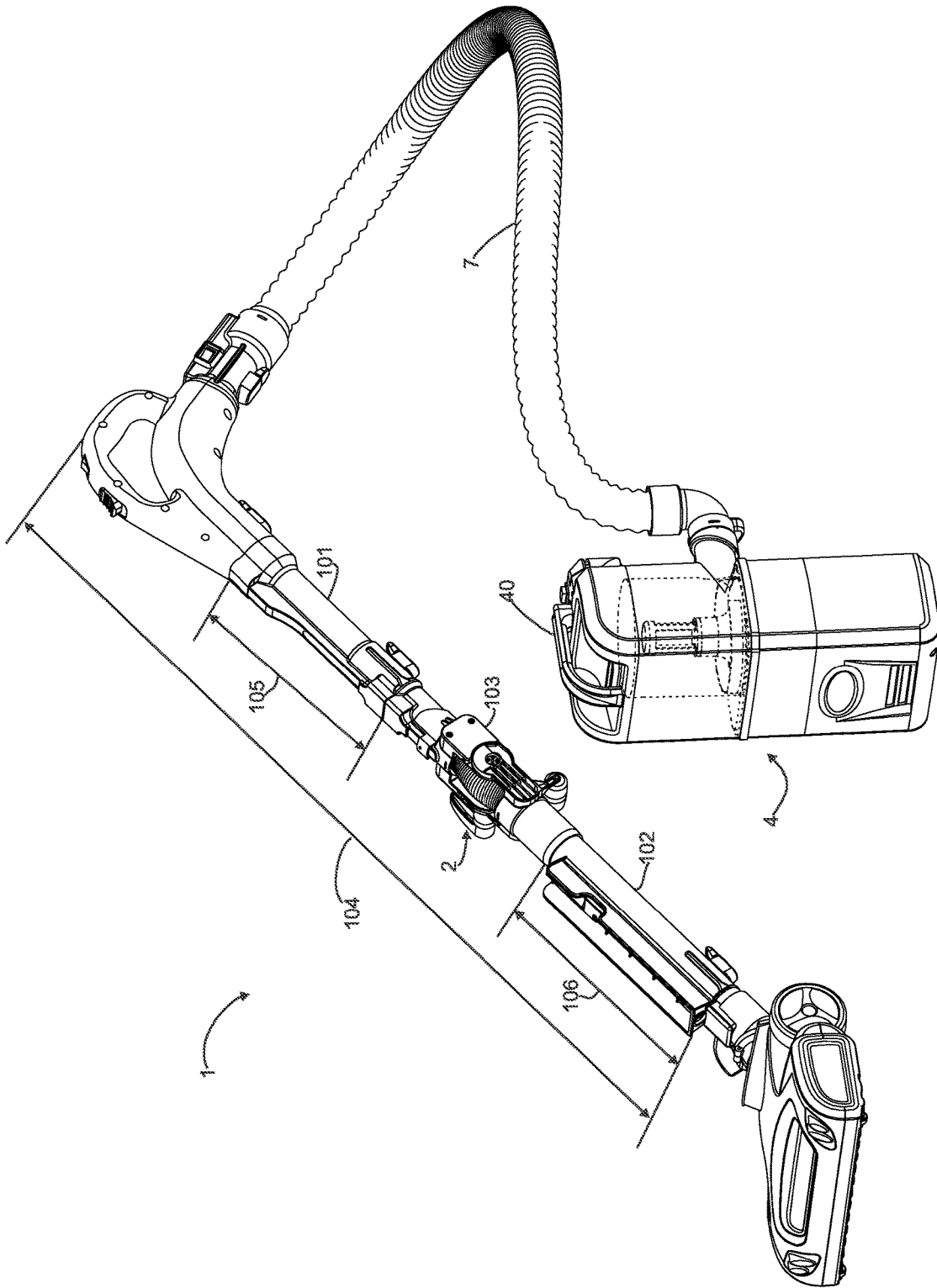

Fig. 9

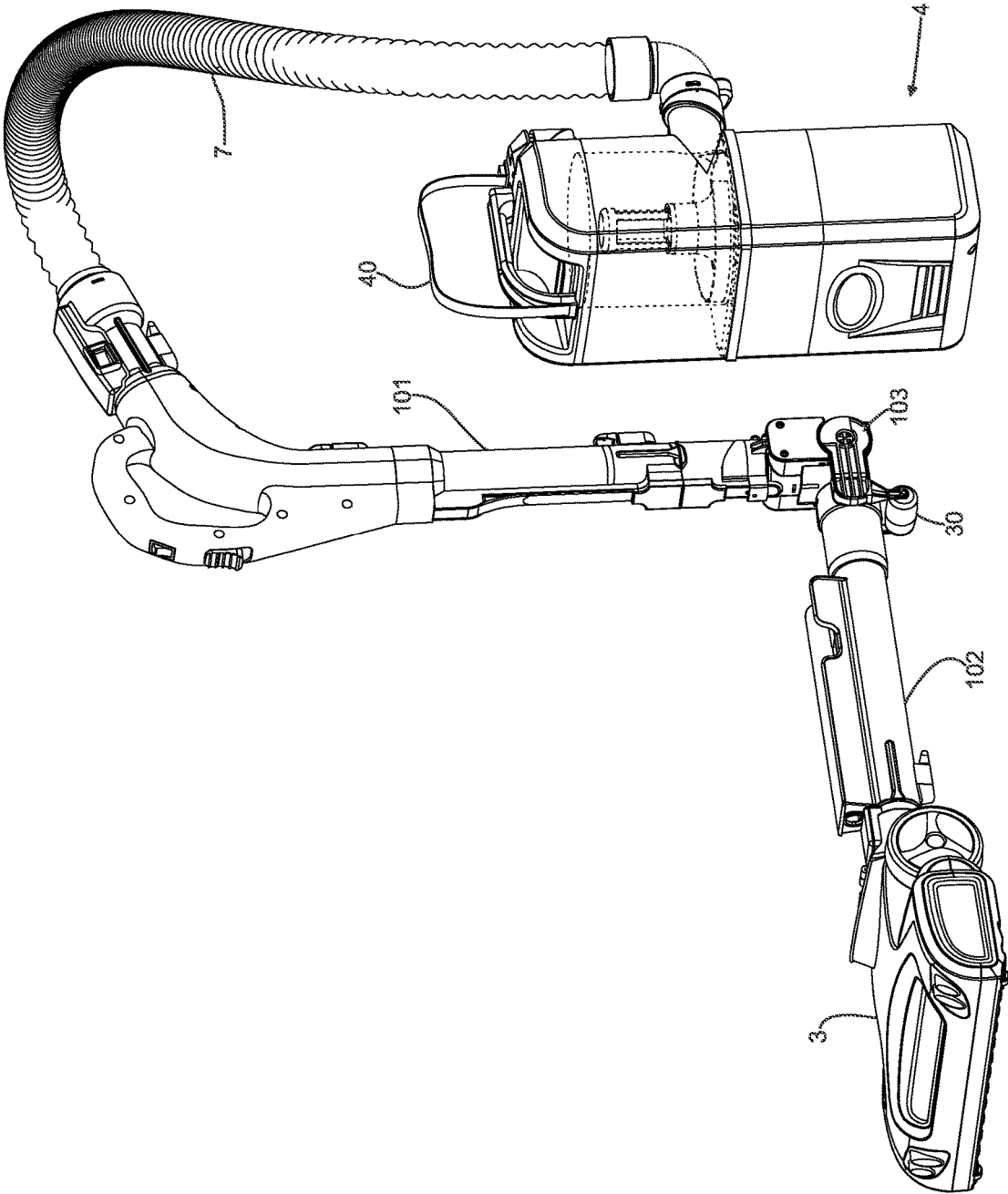

Fig. 10

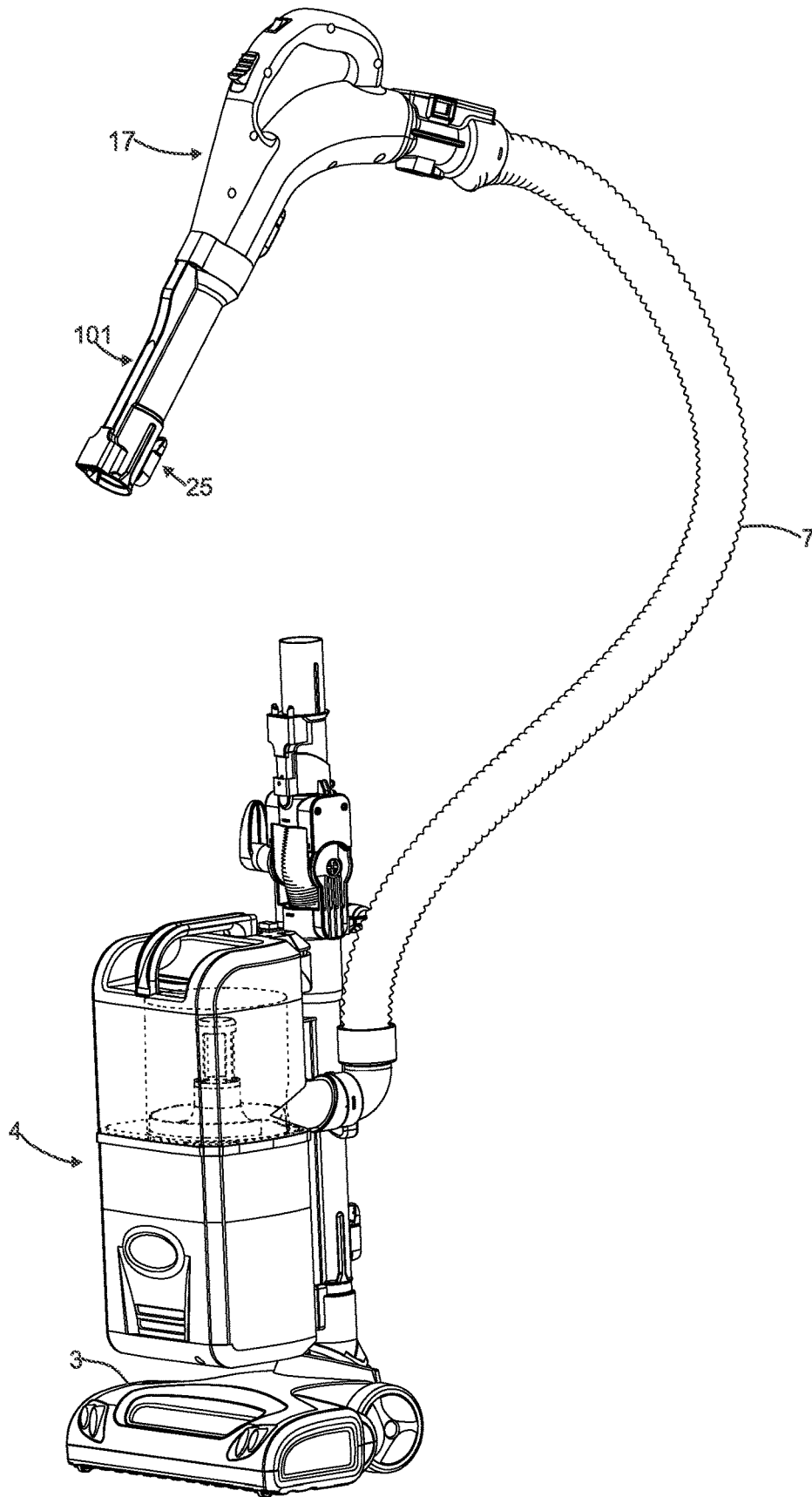

Fig. 11

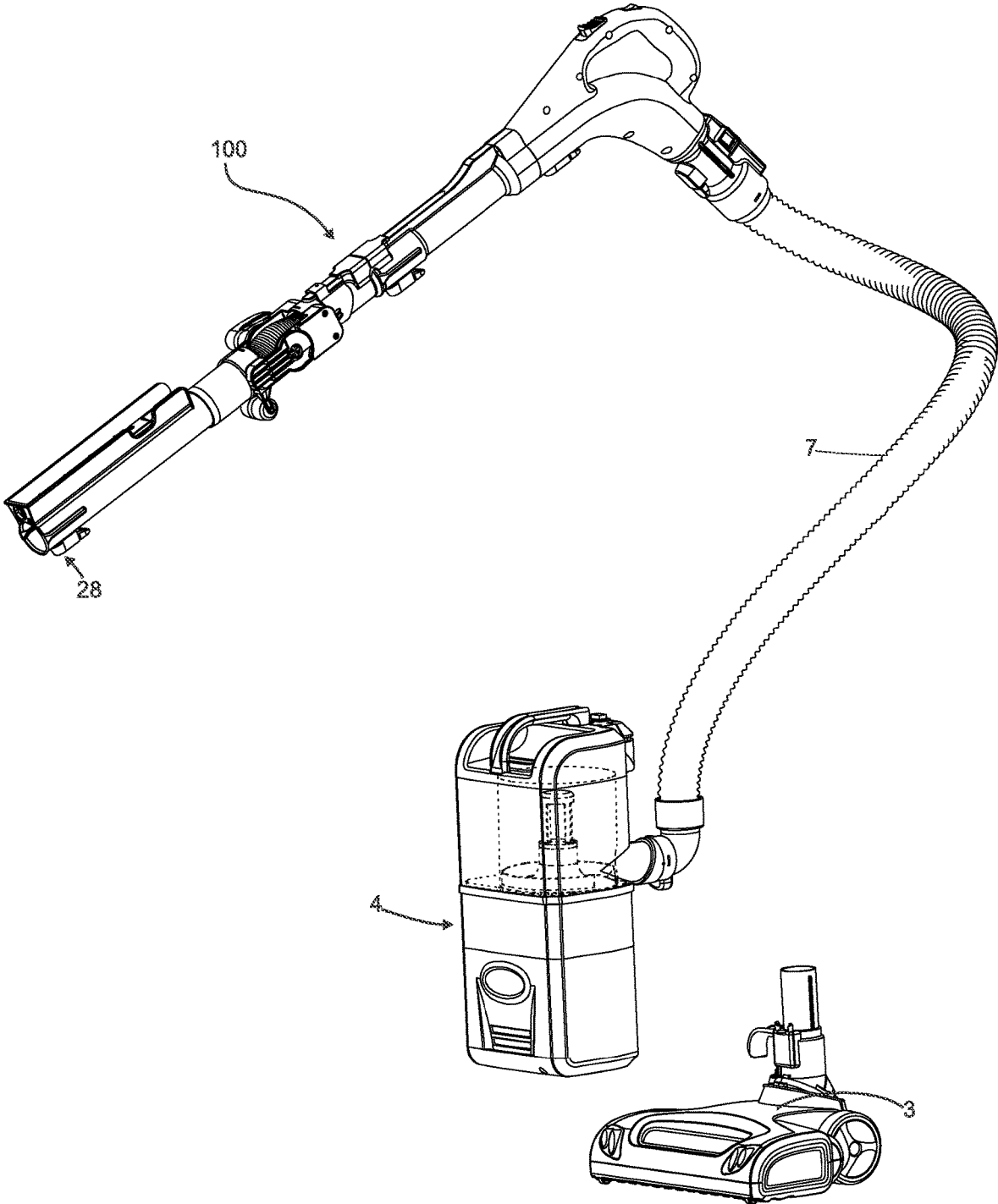

Fig. 12

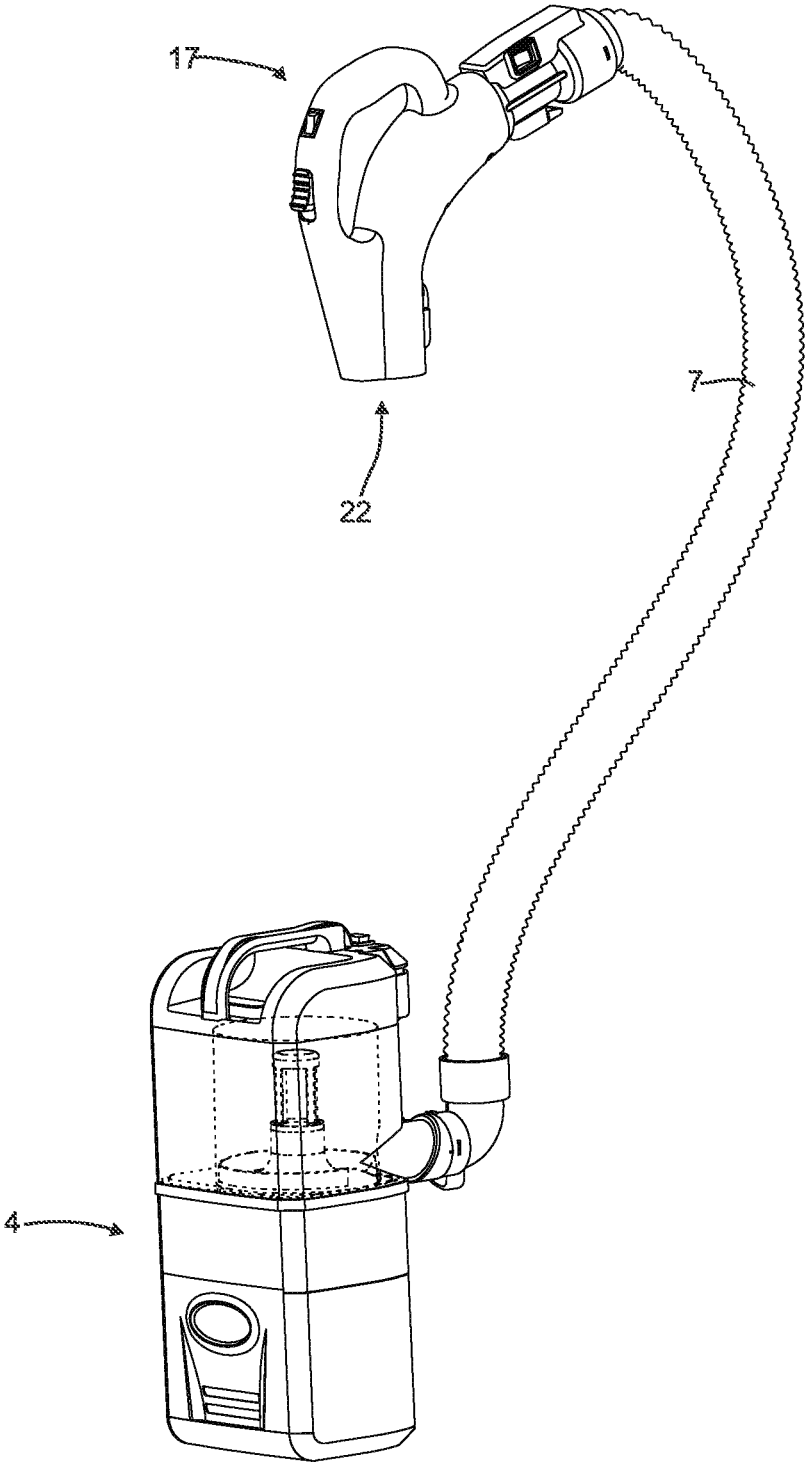

Fig. 13

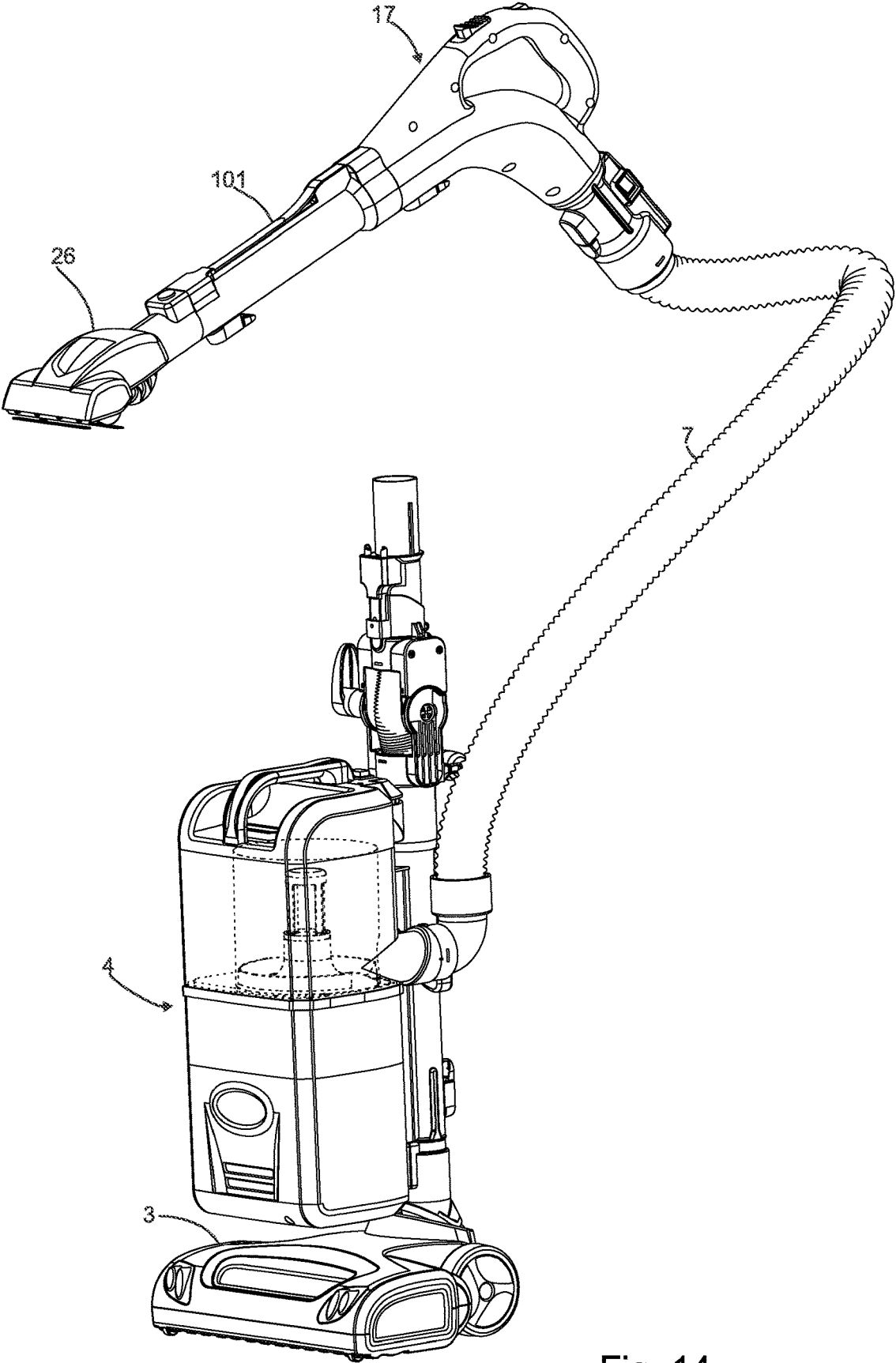

Fig. 14

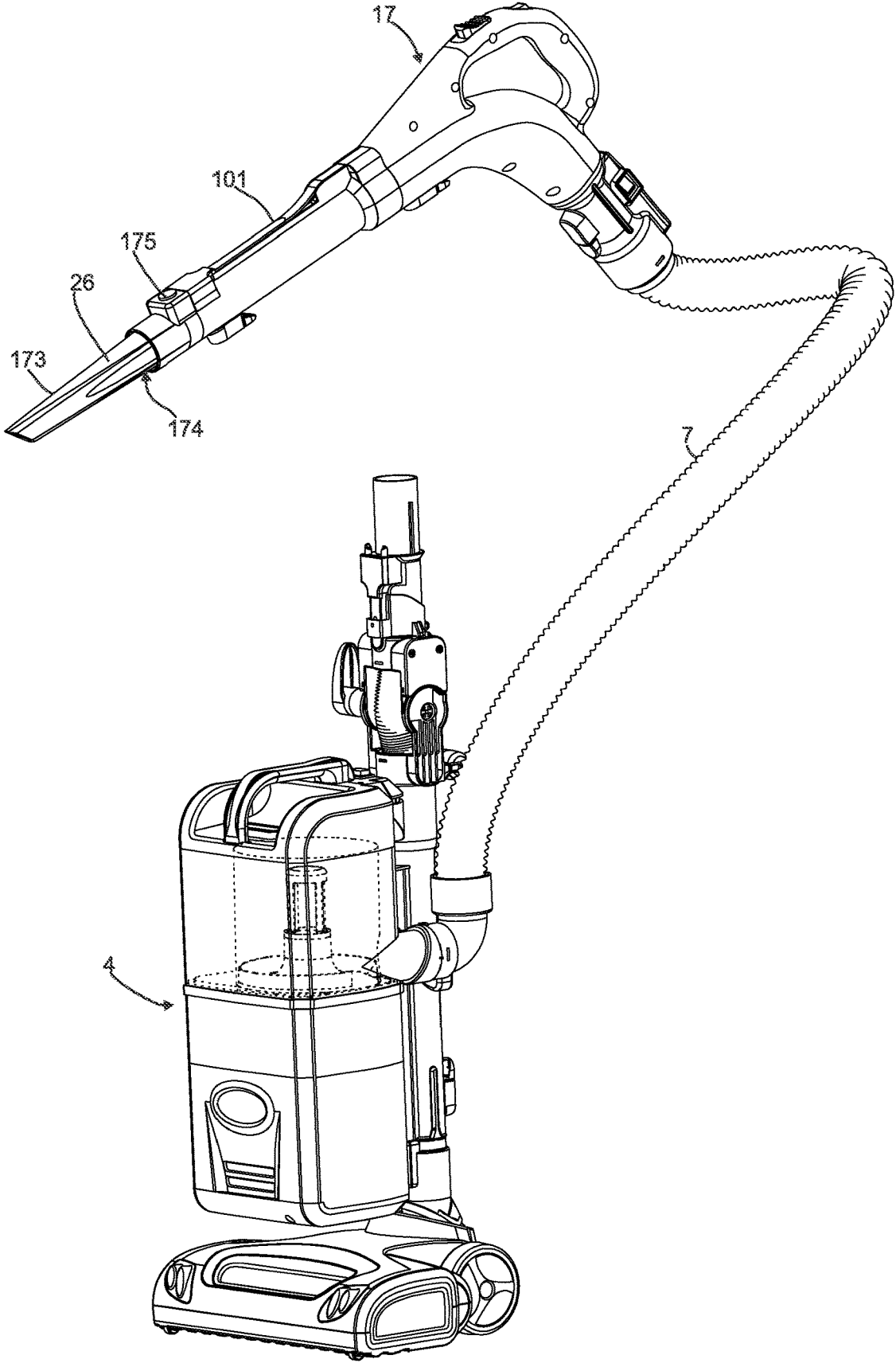

Fig. 15

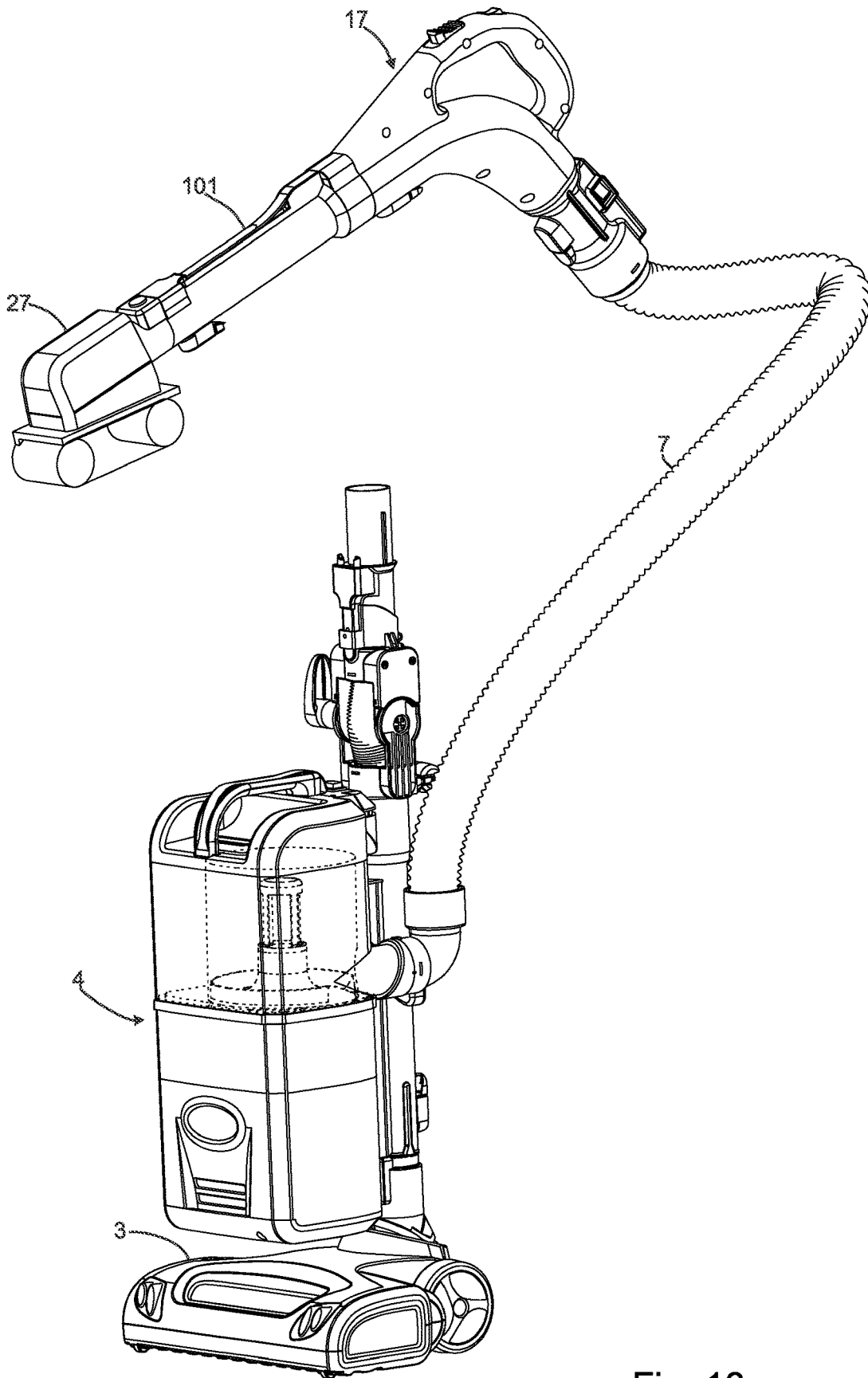

Fig. 16

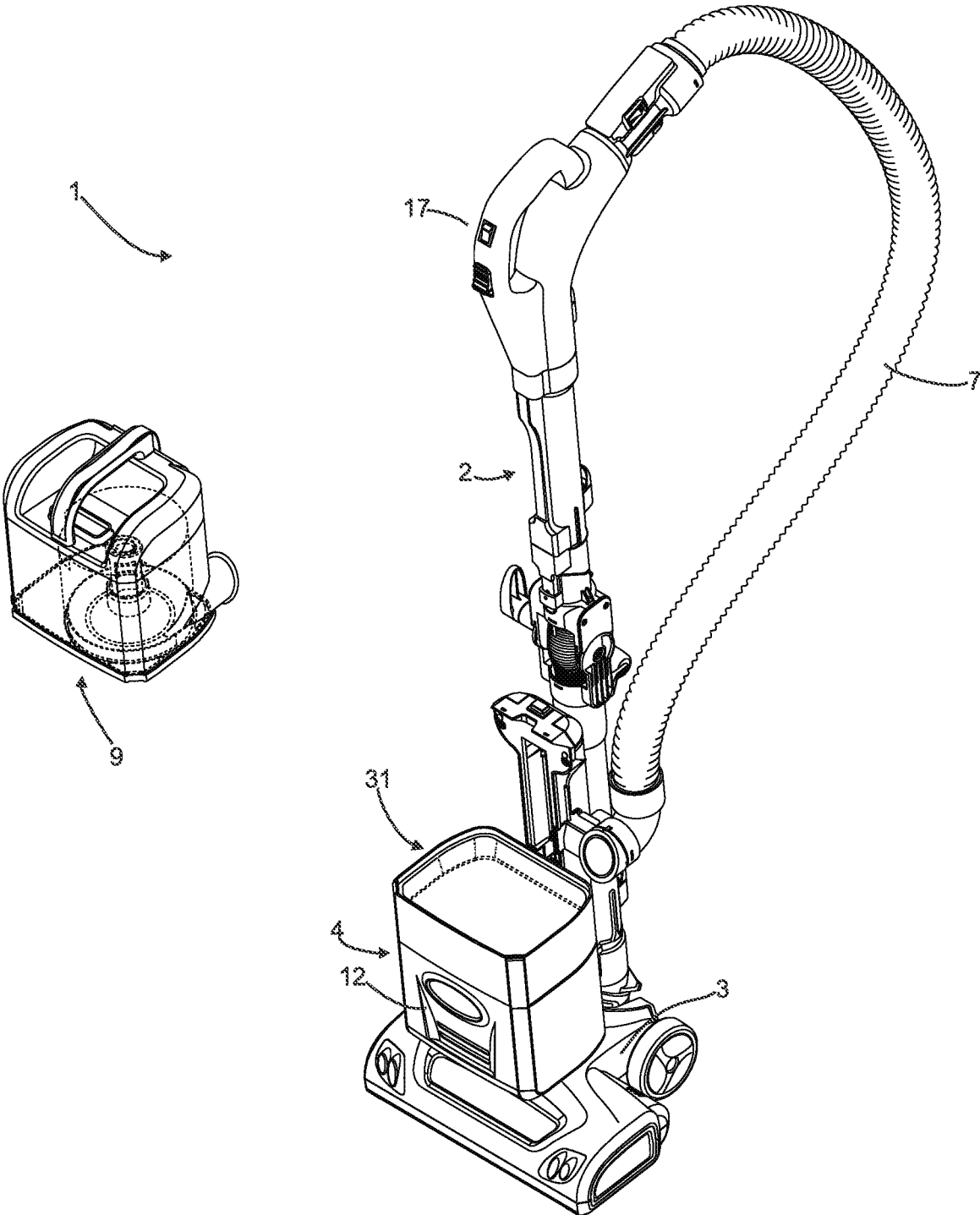

Fig. 17

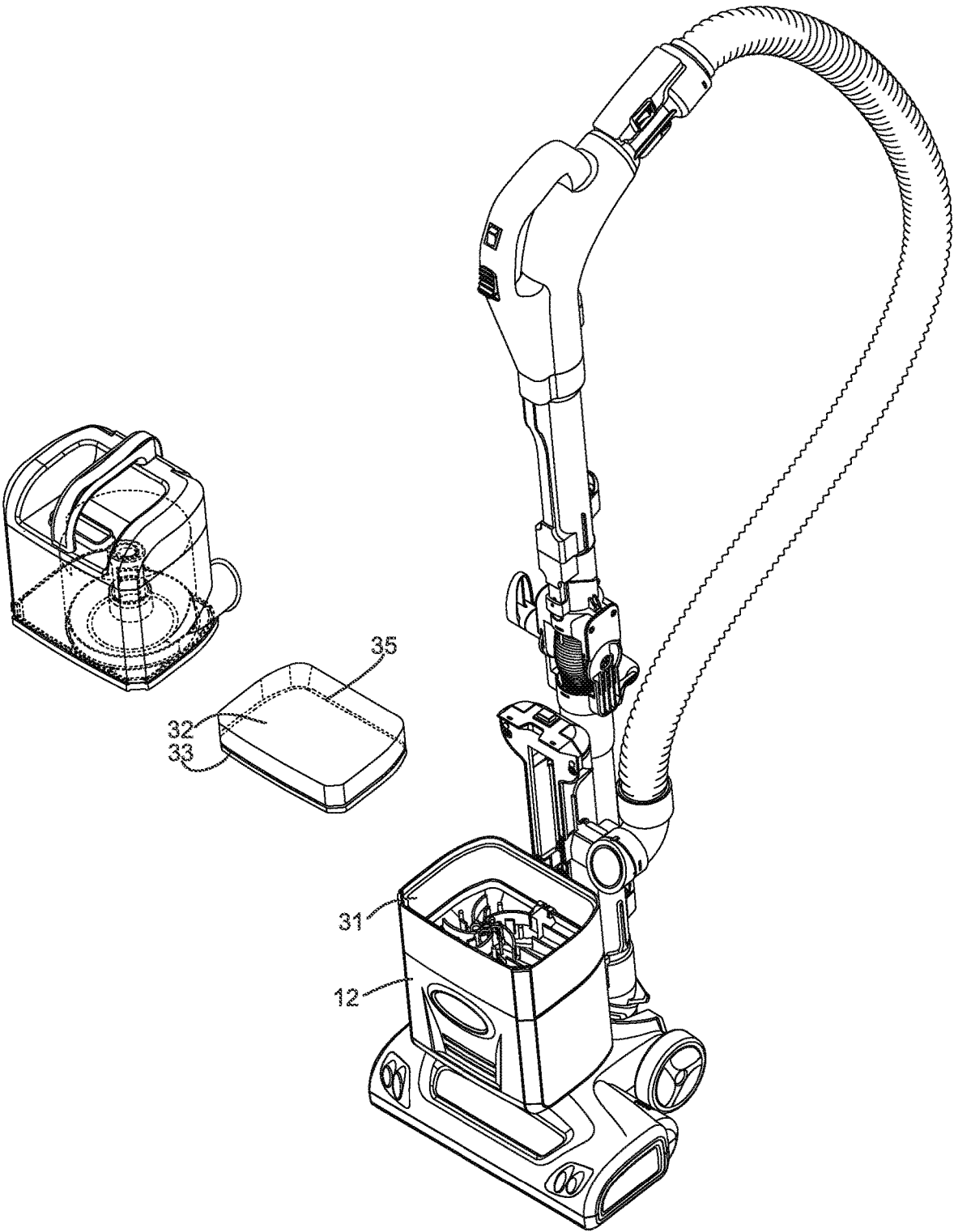

Fig. 18

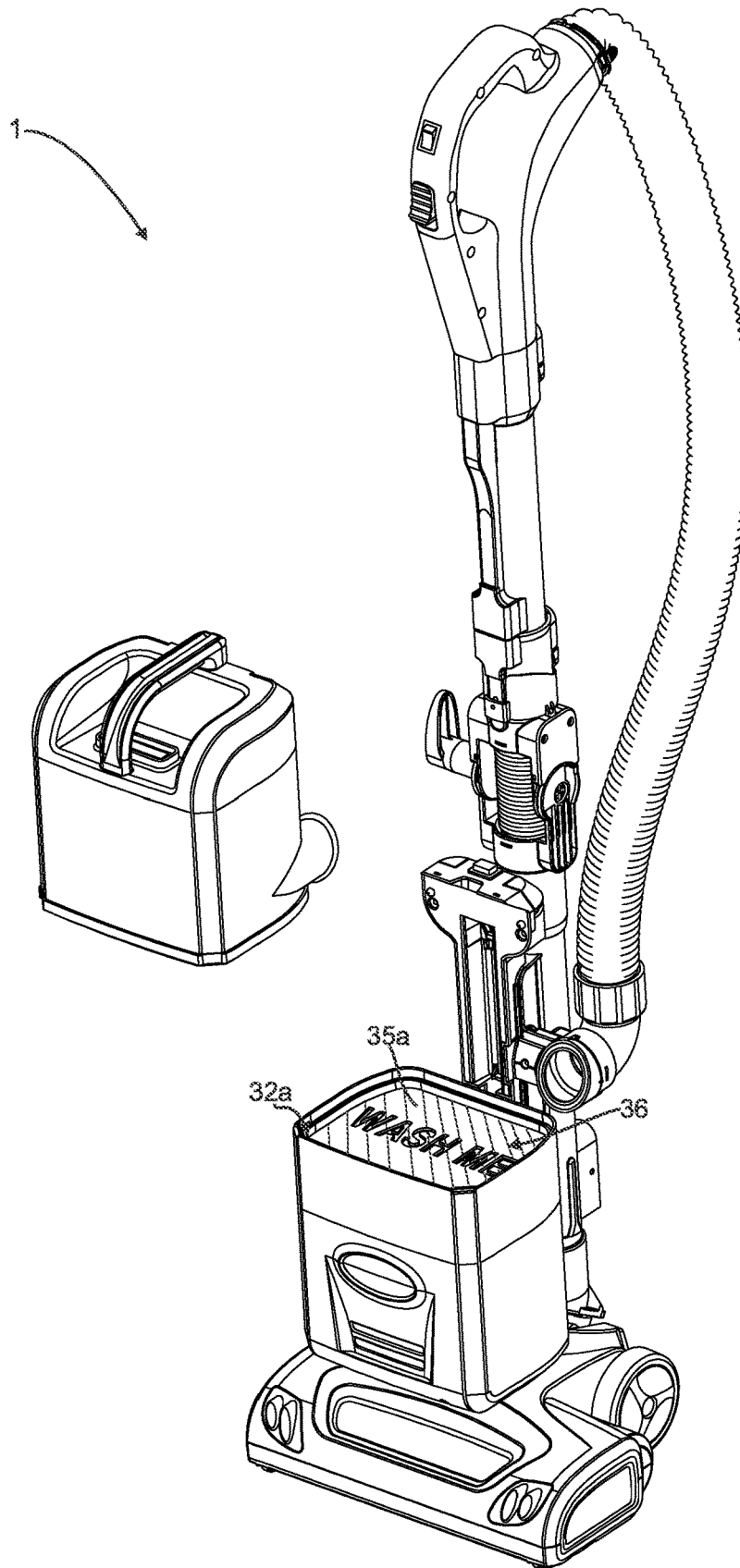

Fig. 19

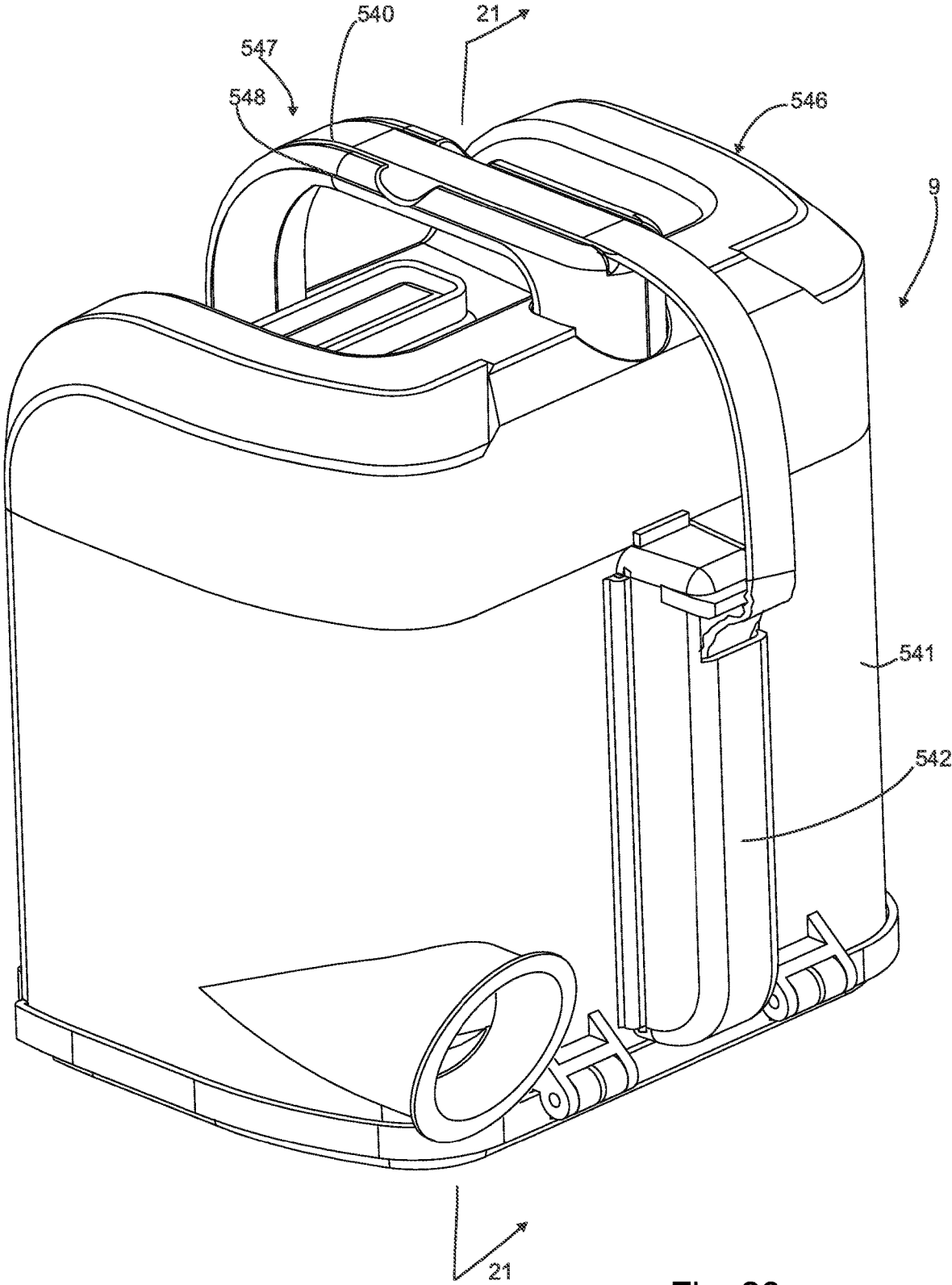

Fig. 20

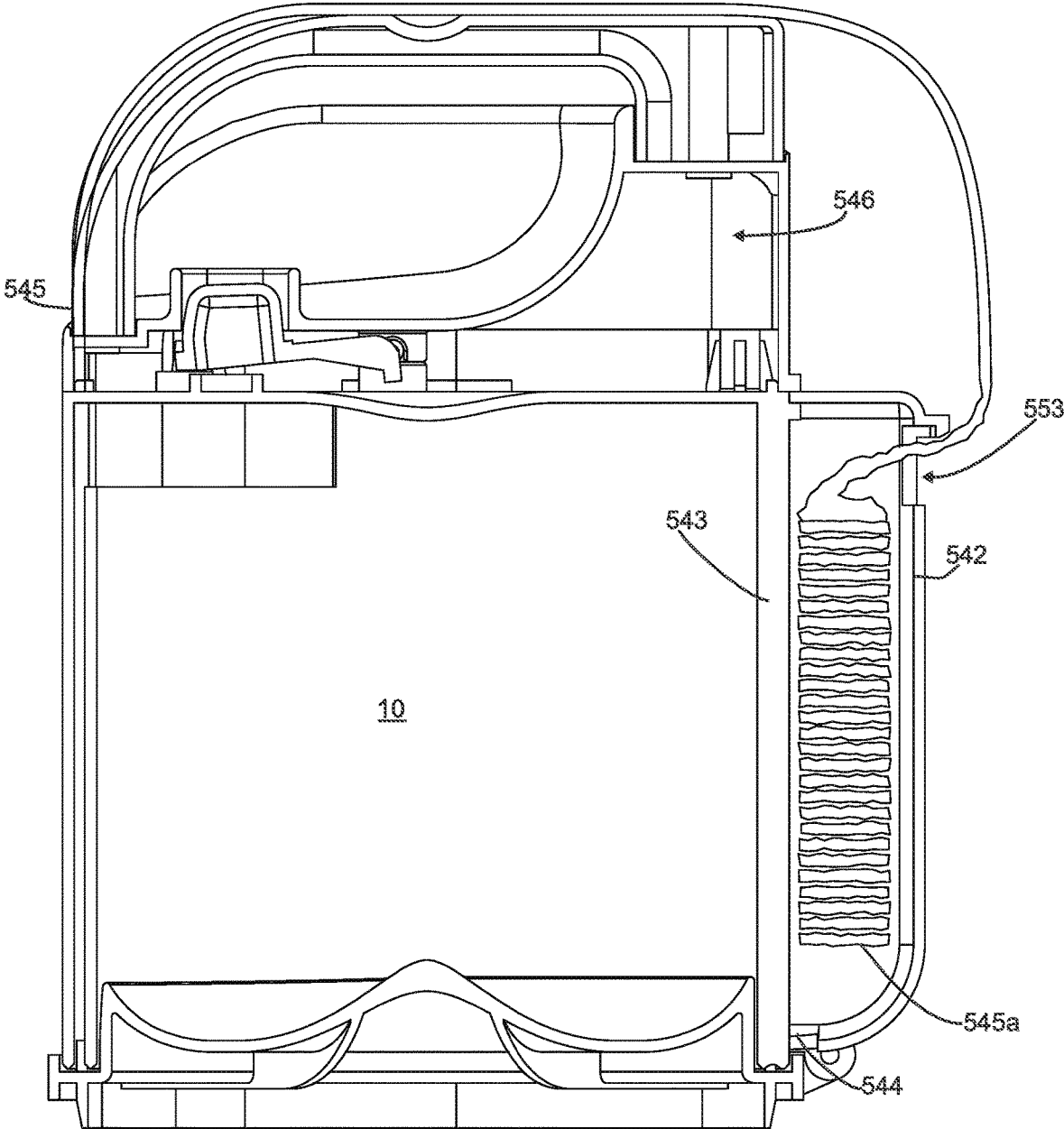

Fig. 21

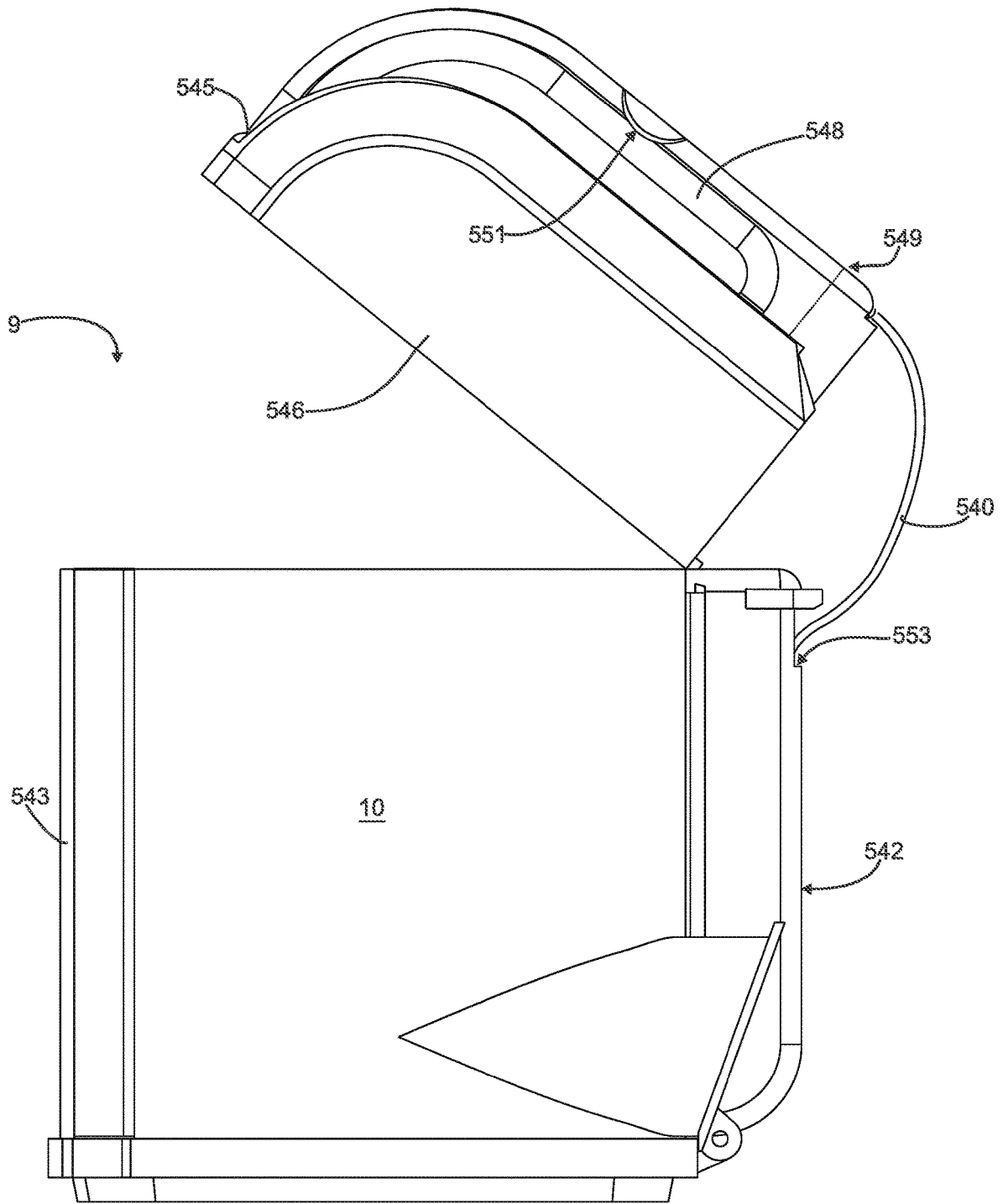

Fig. 22

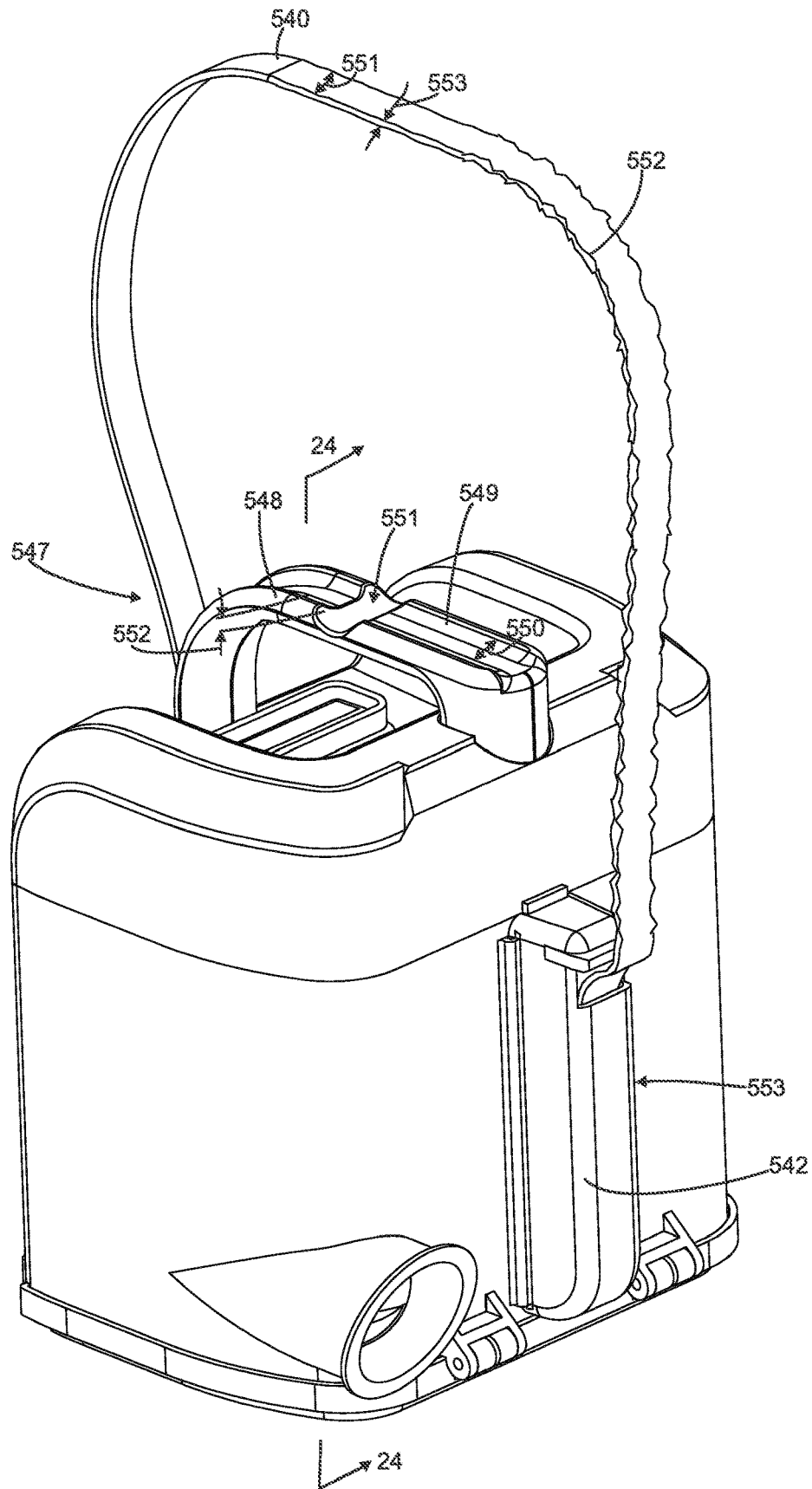

Fig. 23

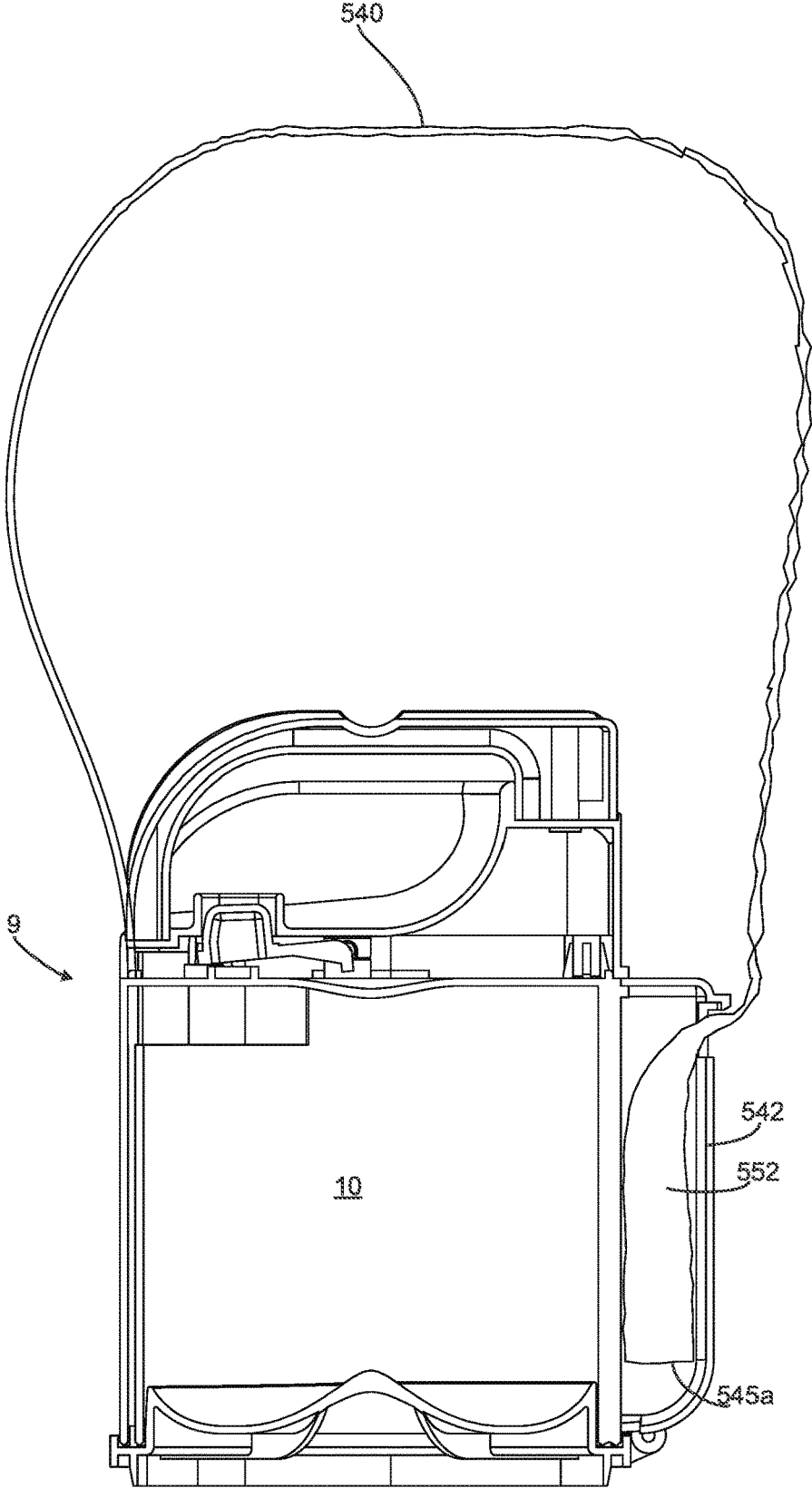

Fig. 24

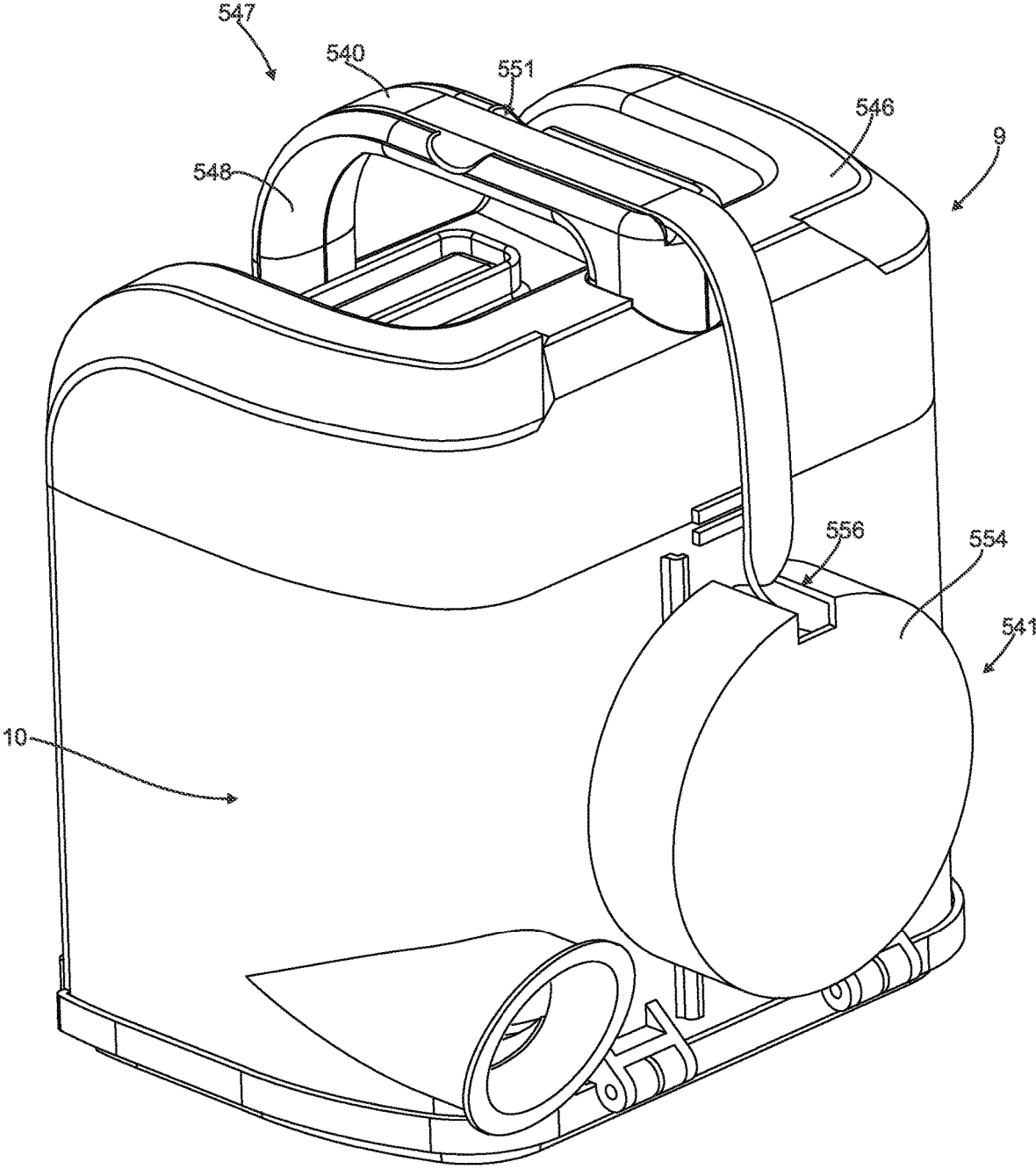

Fig. 25

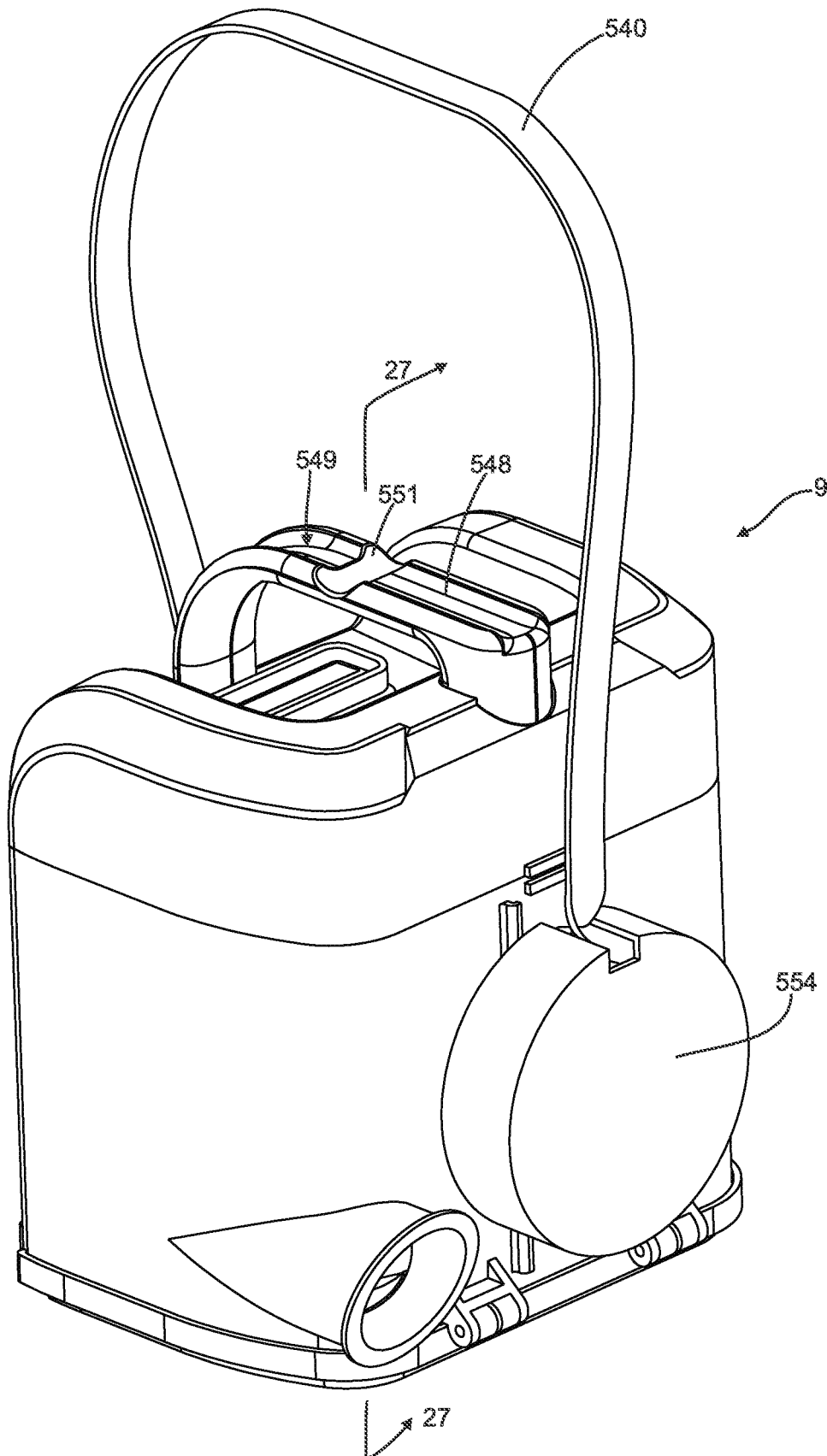

Fig. 26

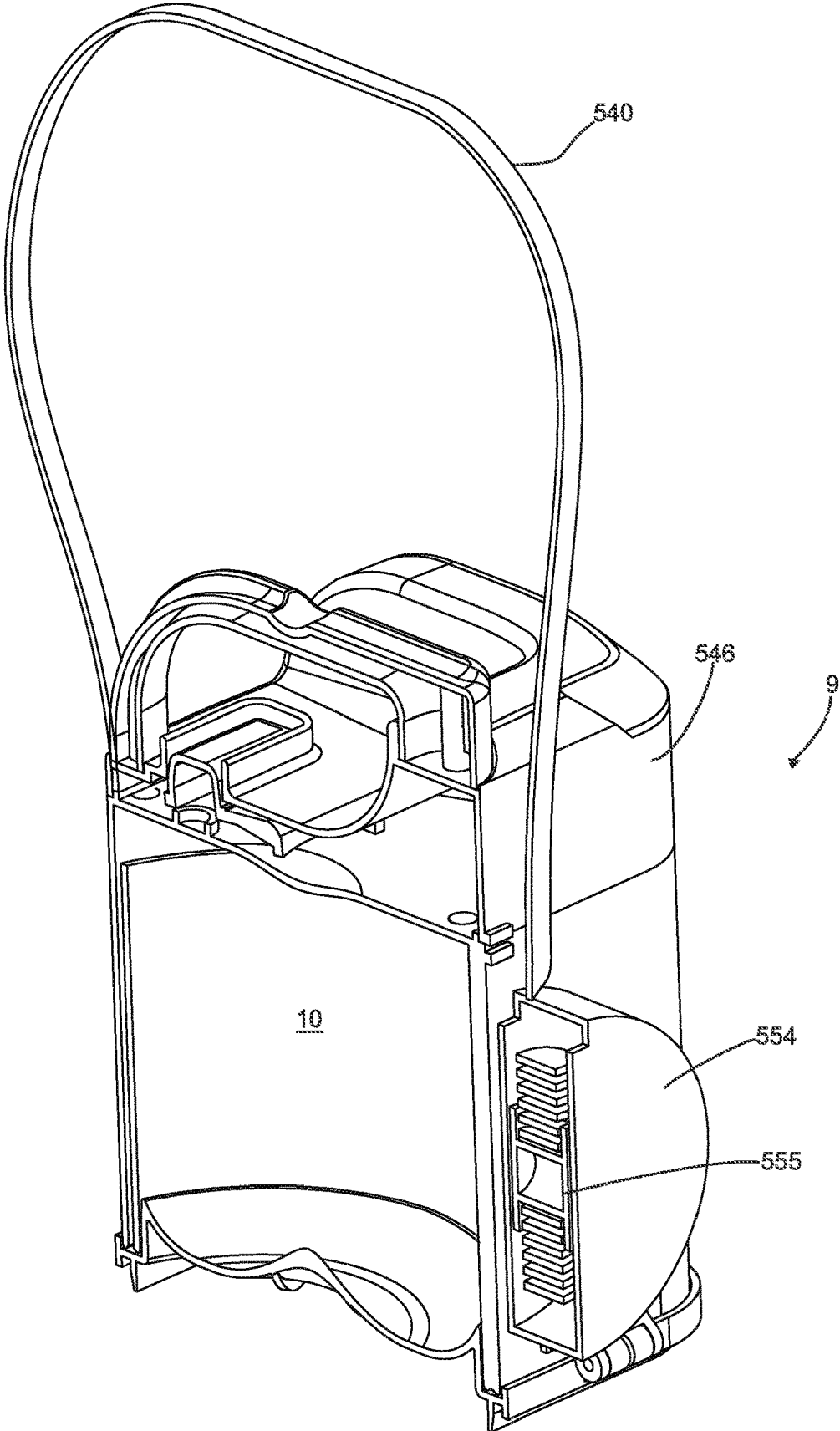

Fig. 27

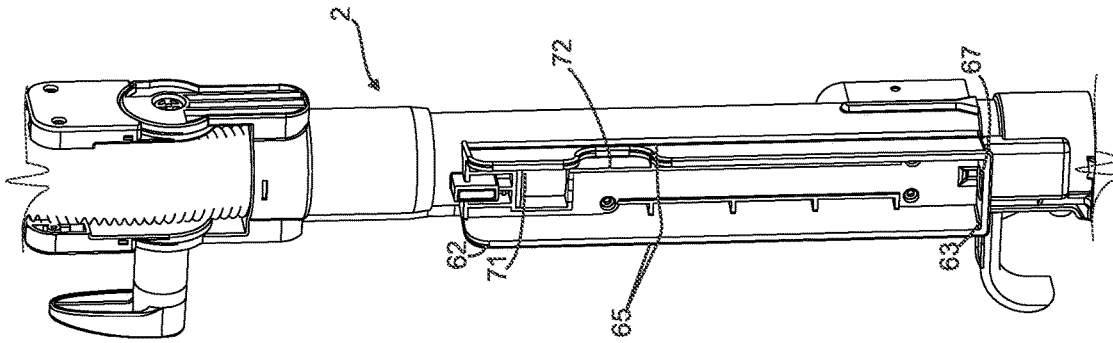

Fig. 28B

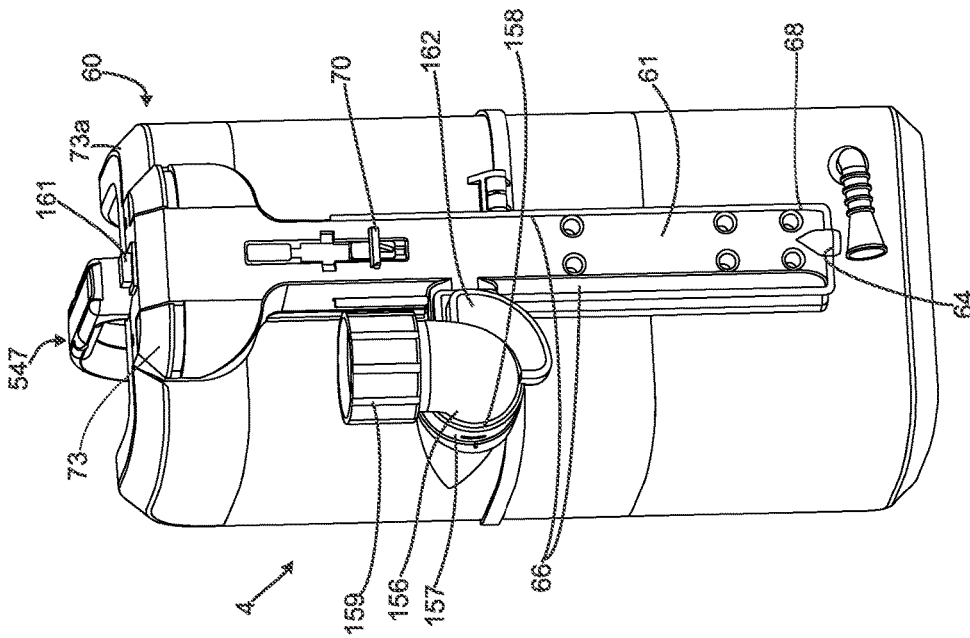

Fig. 28A

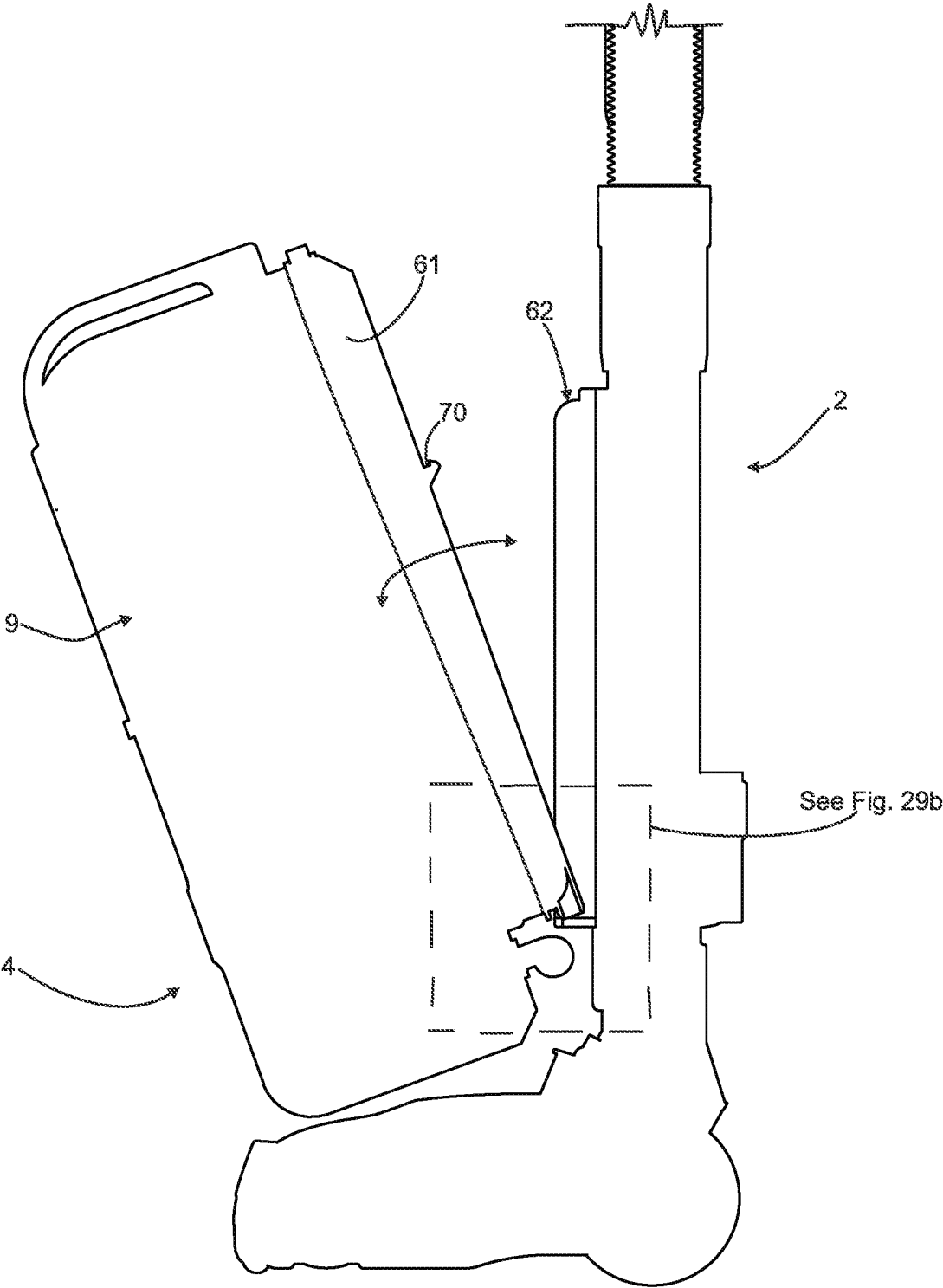

Fig. 29A

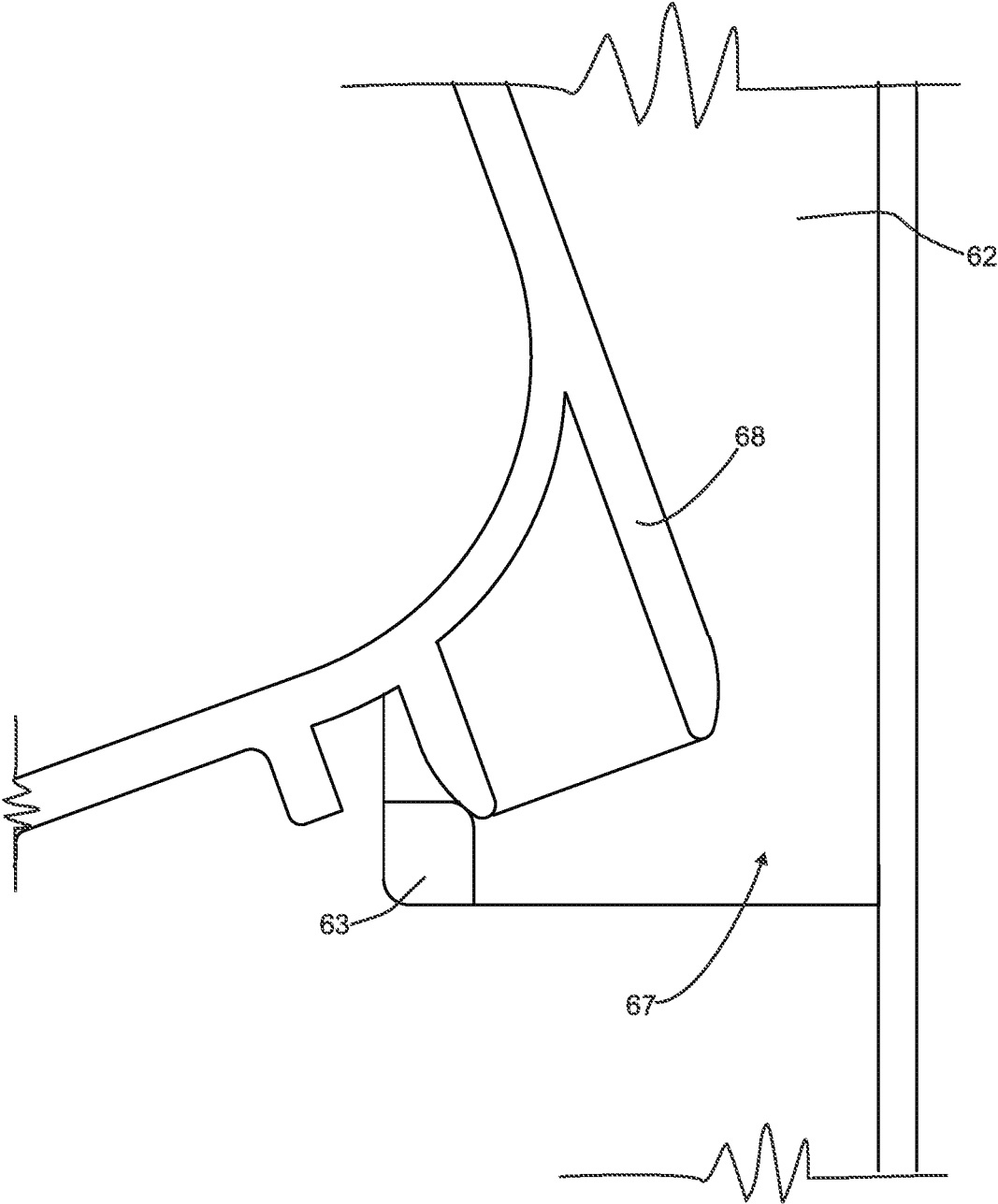

Fig. 29B

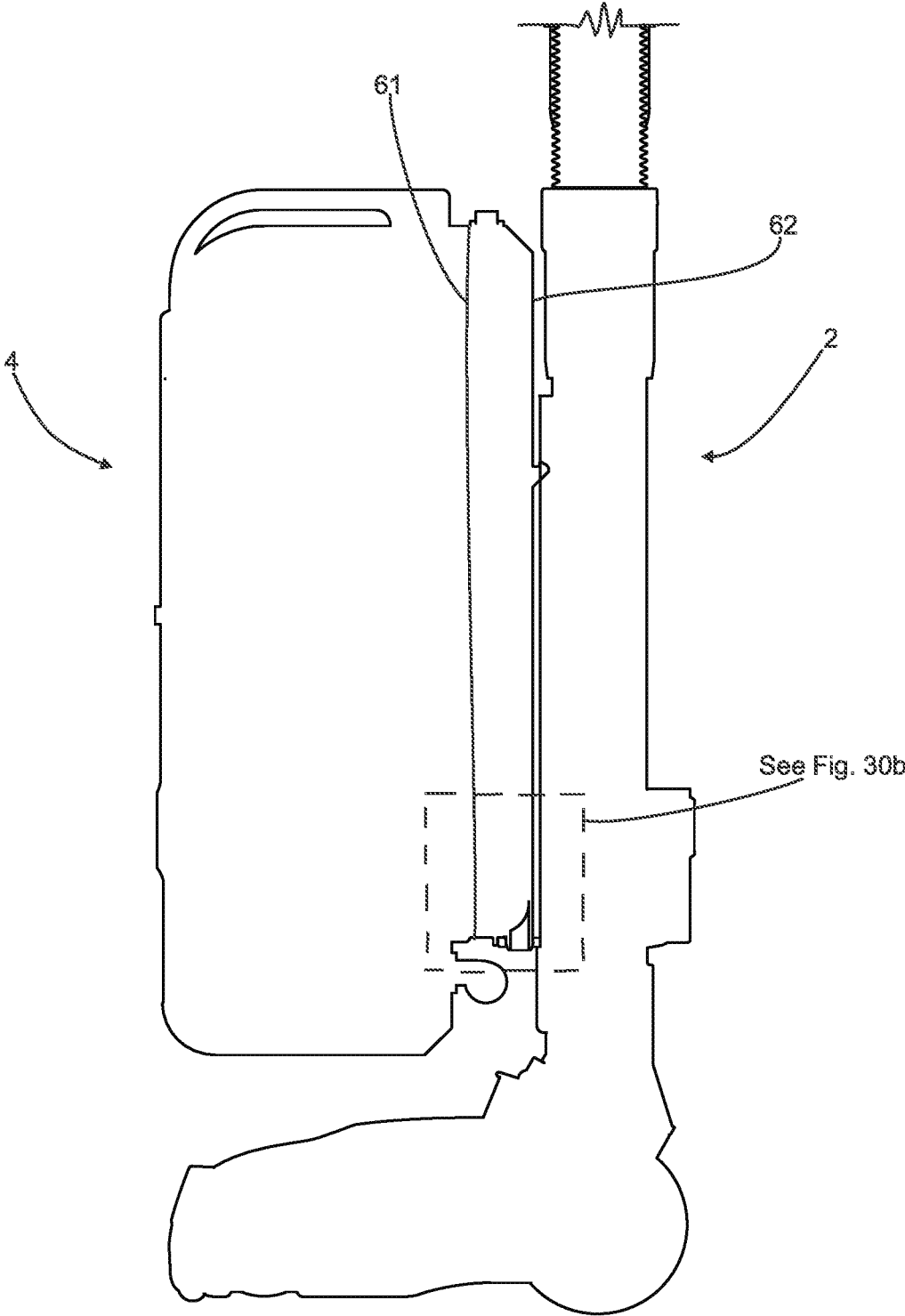

Fig. 30A

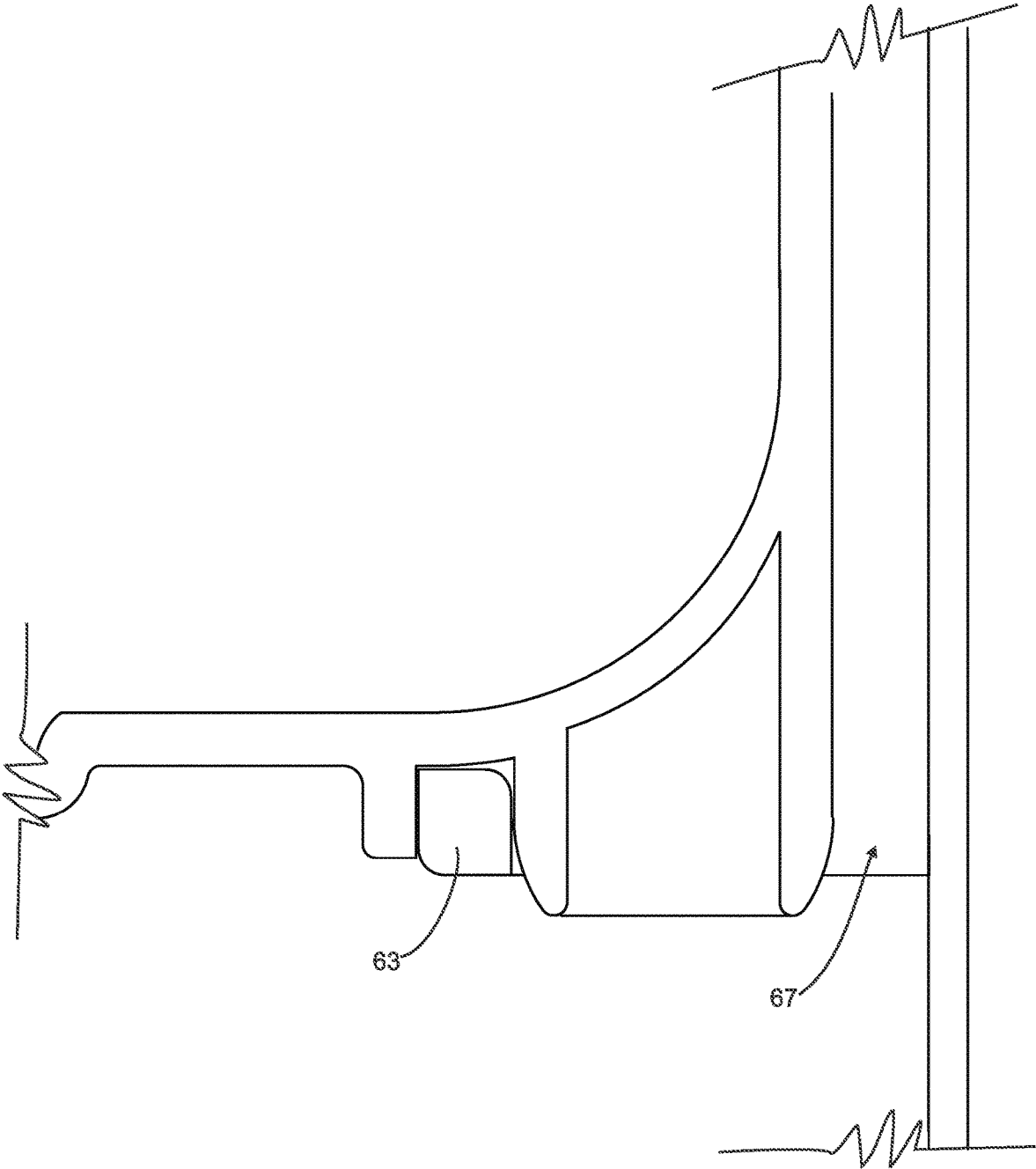

Fig. 30B

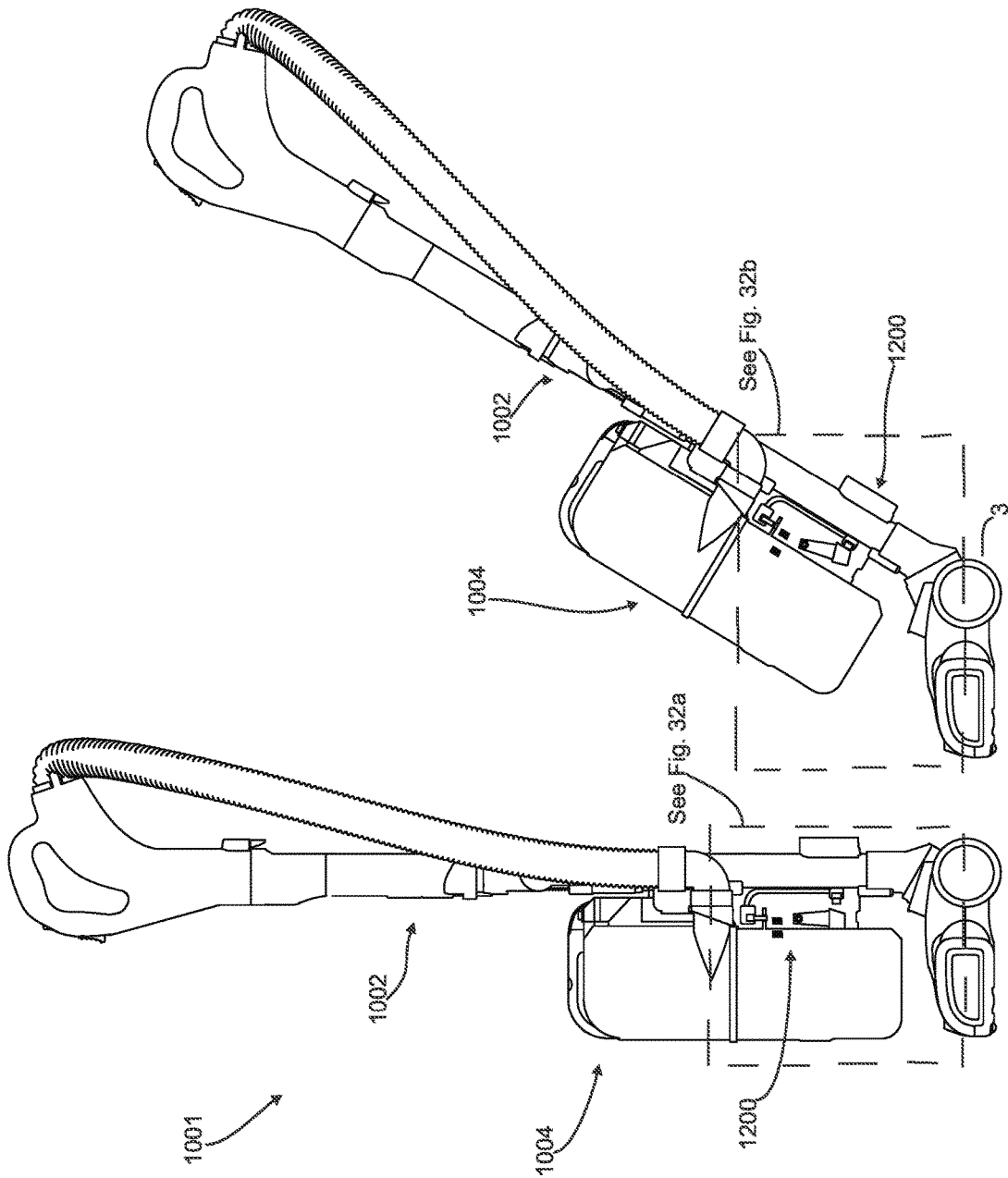

Fig. 31B

Fig. 31A

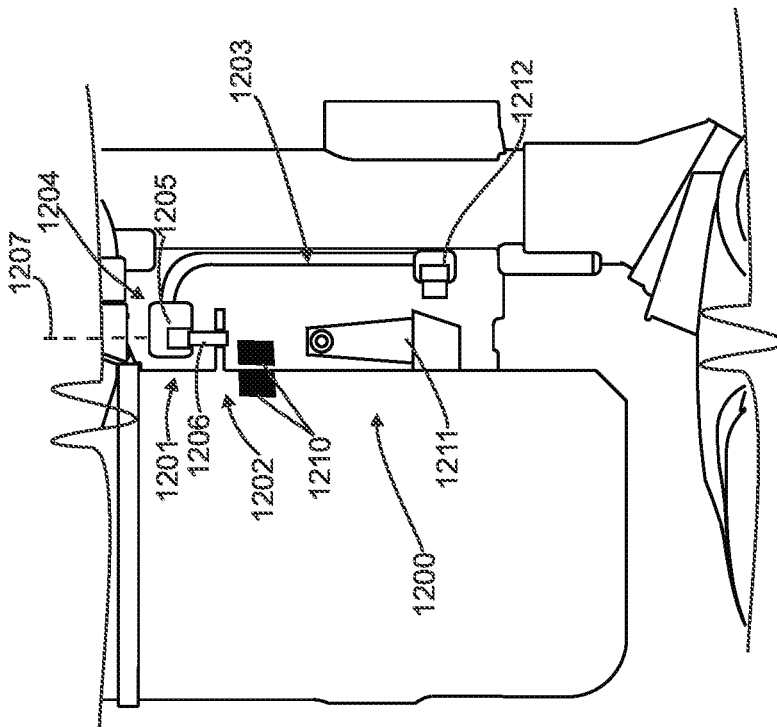

Fig. 32A

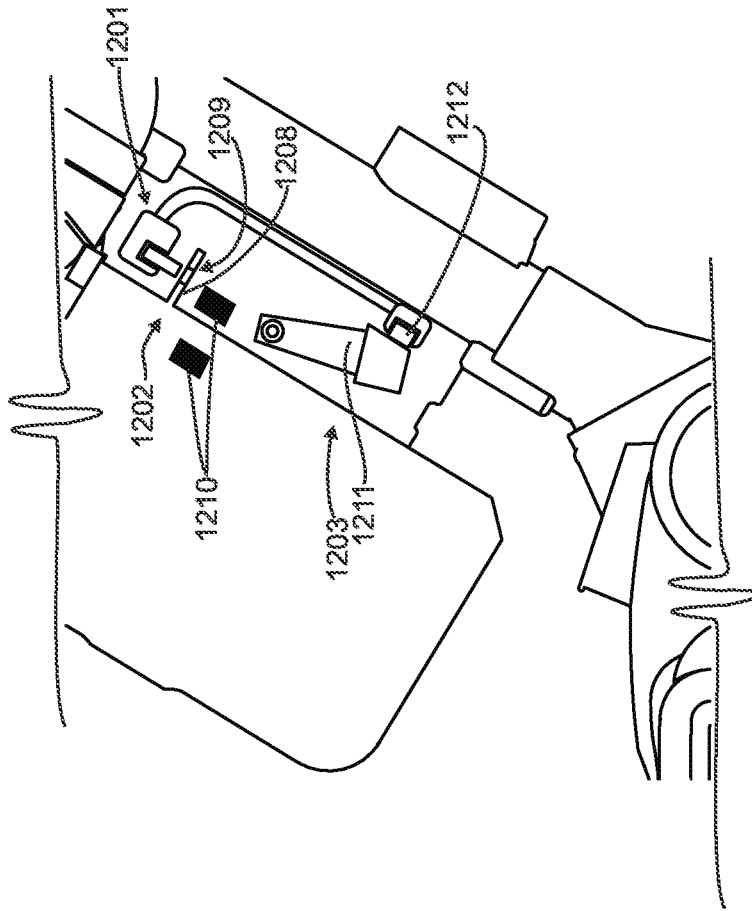

Fig. 32B

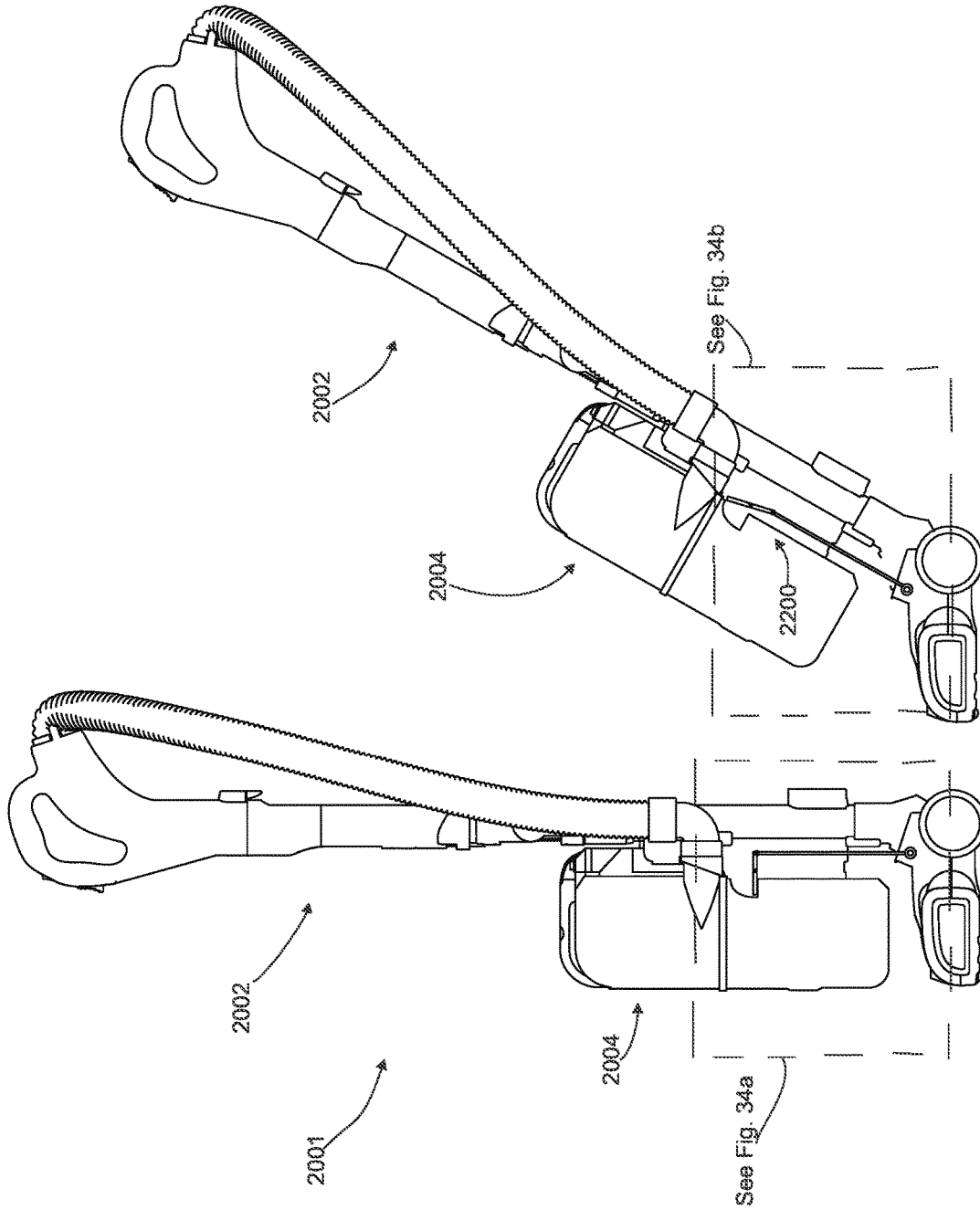

Fig. 33B

Fig. 33A

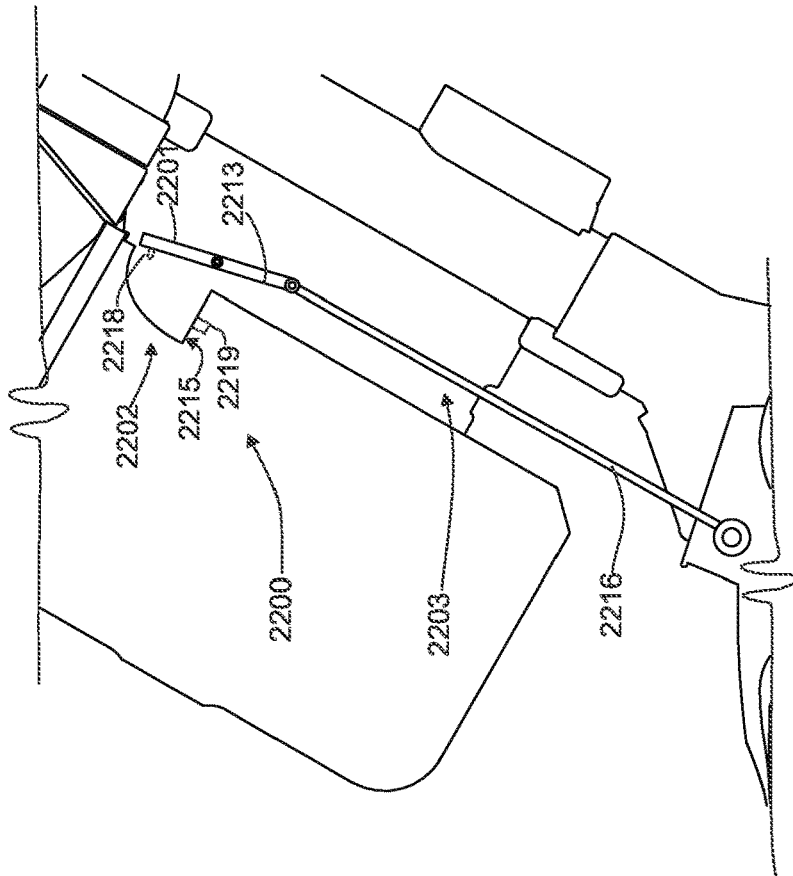

Fig. 34B

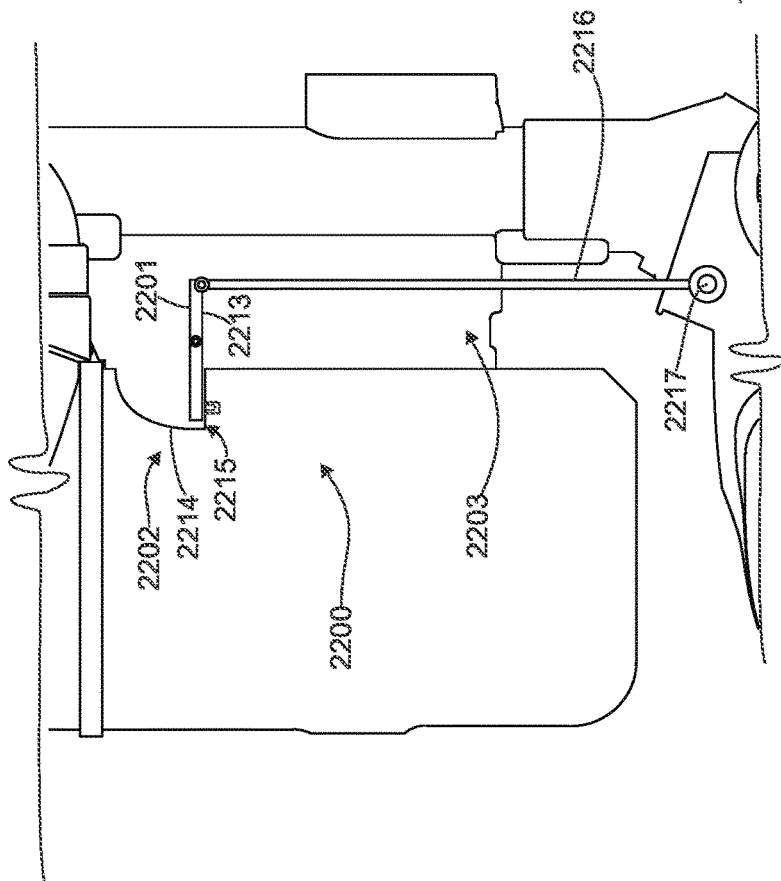

Fig. 34A

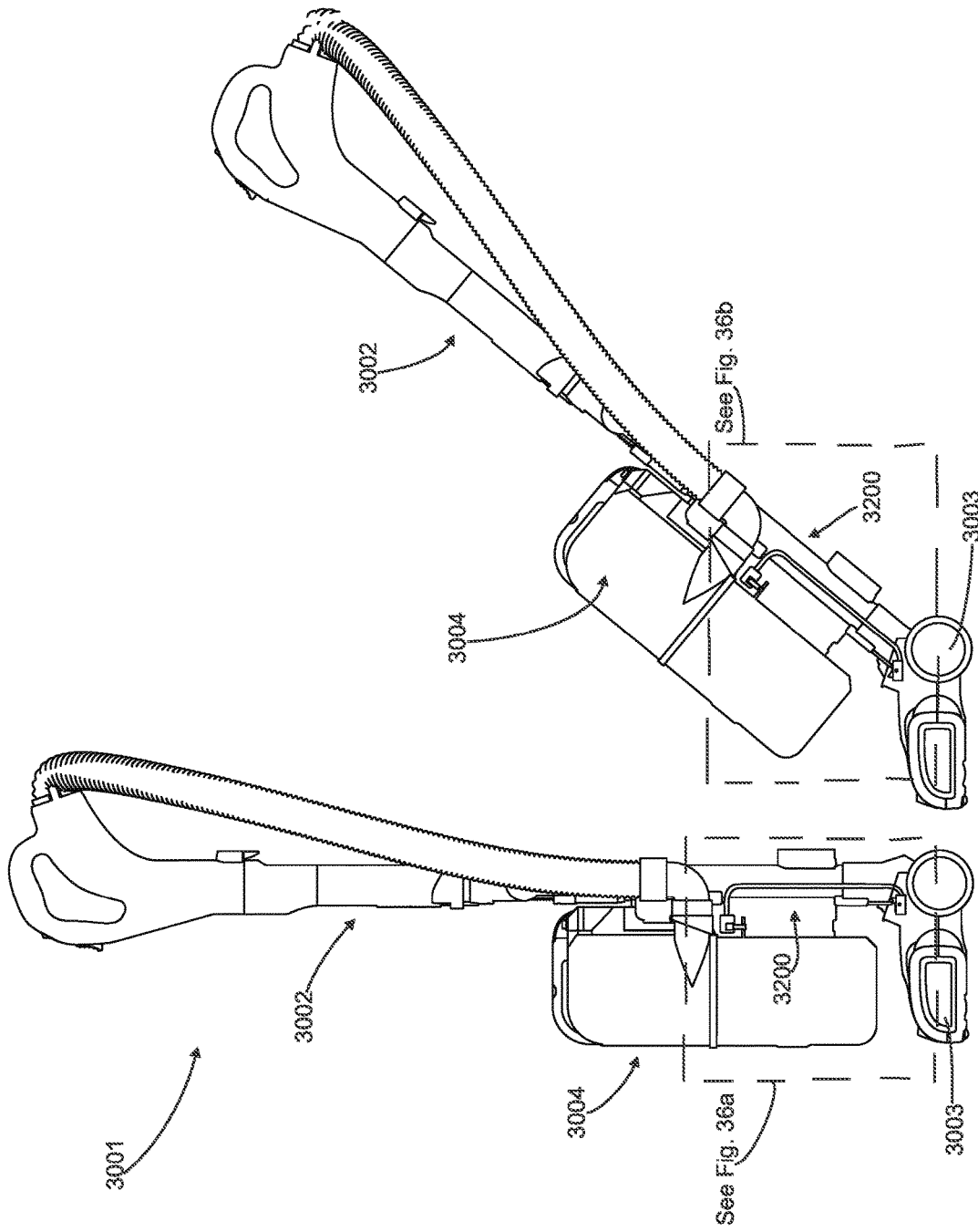

Fig. 35B

Fig. 35A

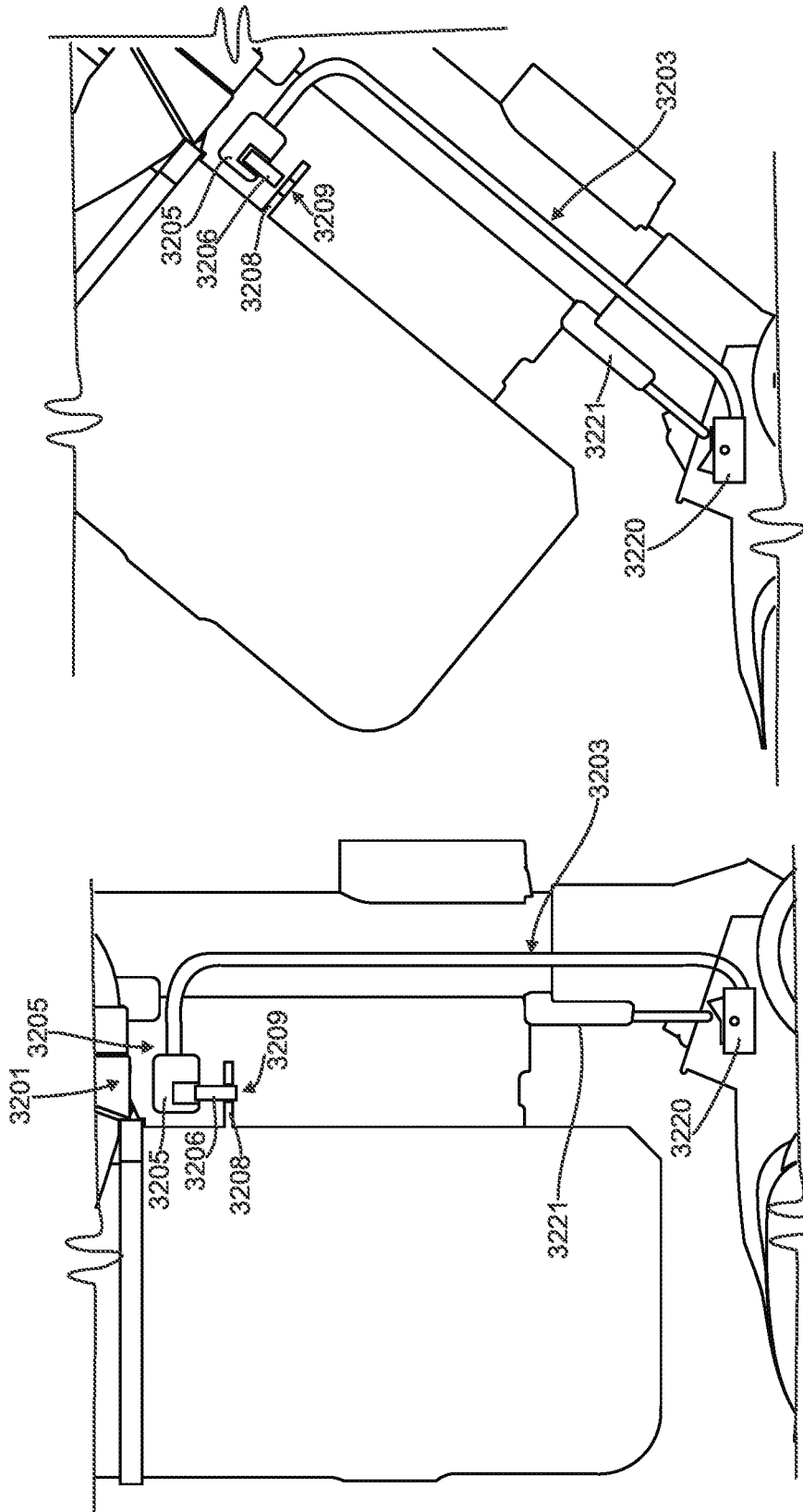

Fig. 36B

Fig. 36A

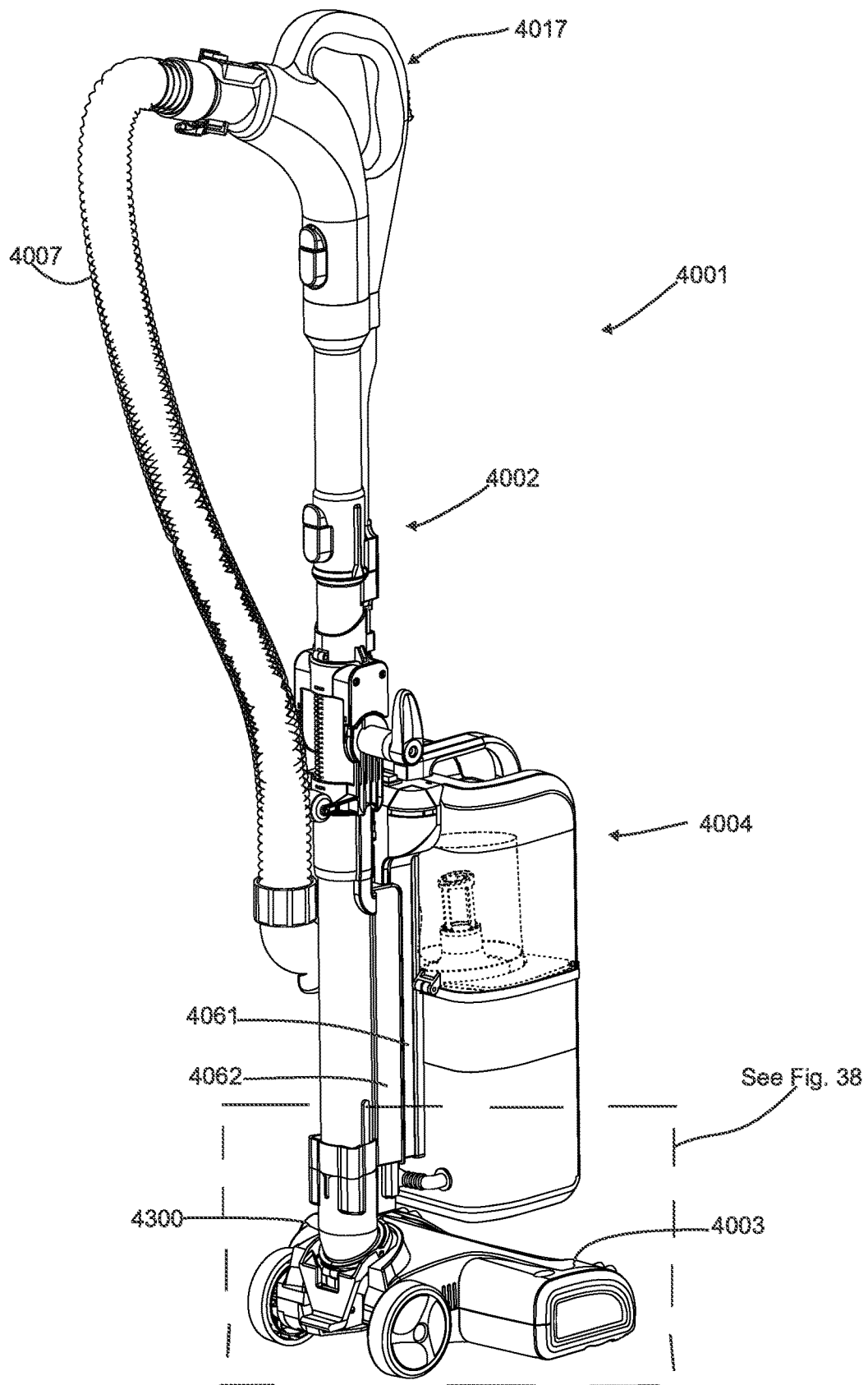

Fig. 37

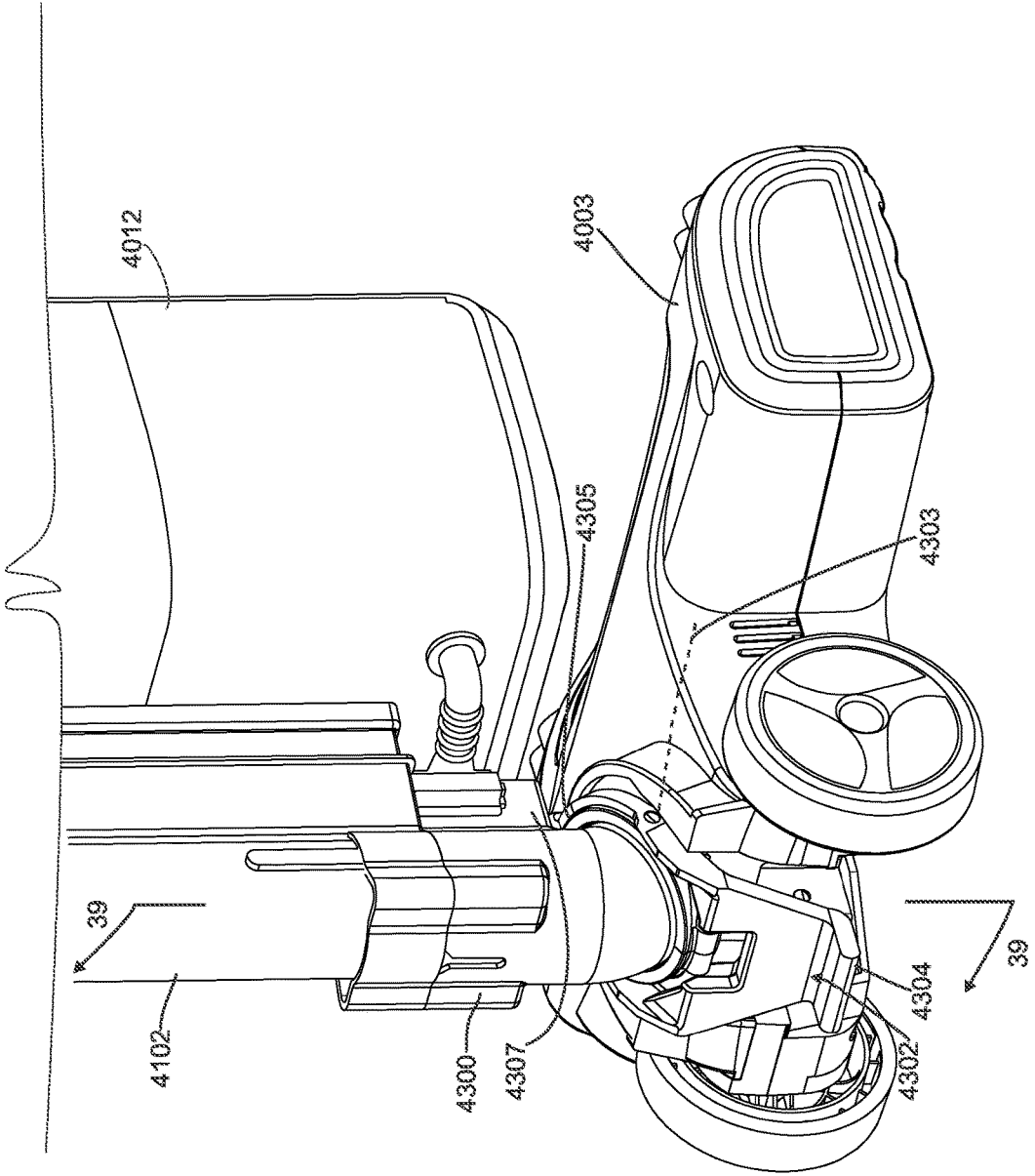

Fig. 38

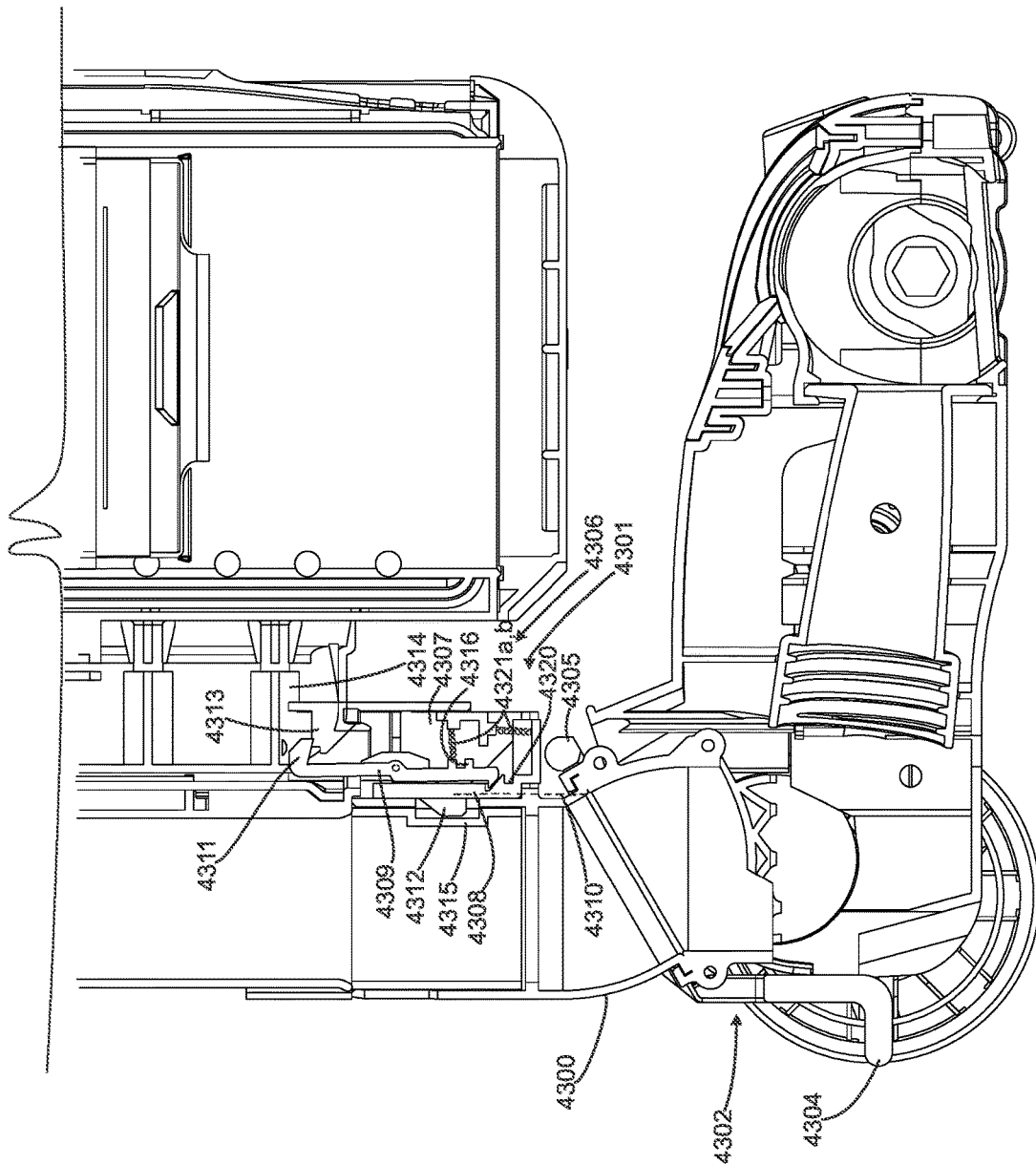

Fig. 39

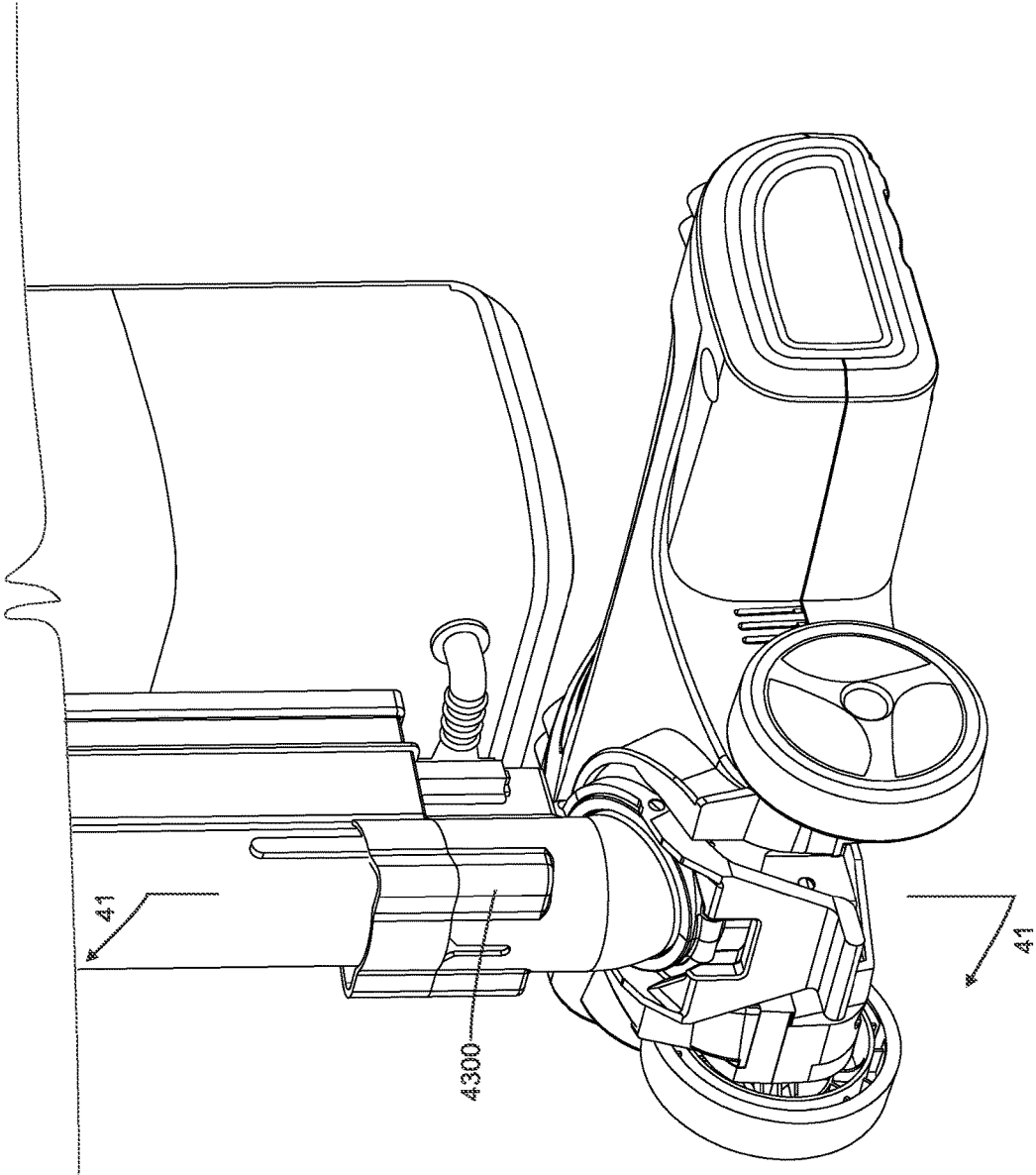

Fig. 40

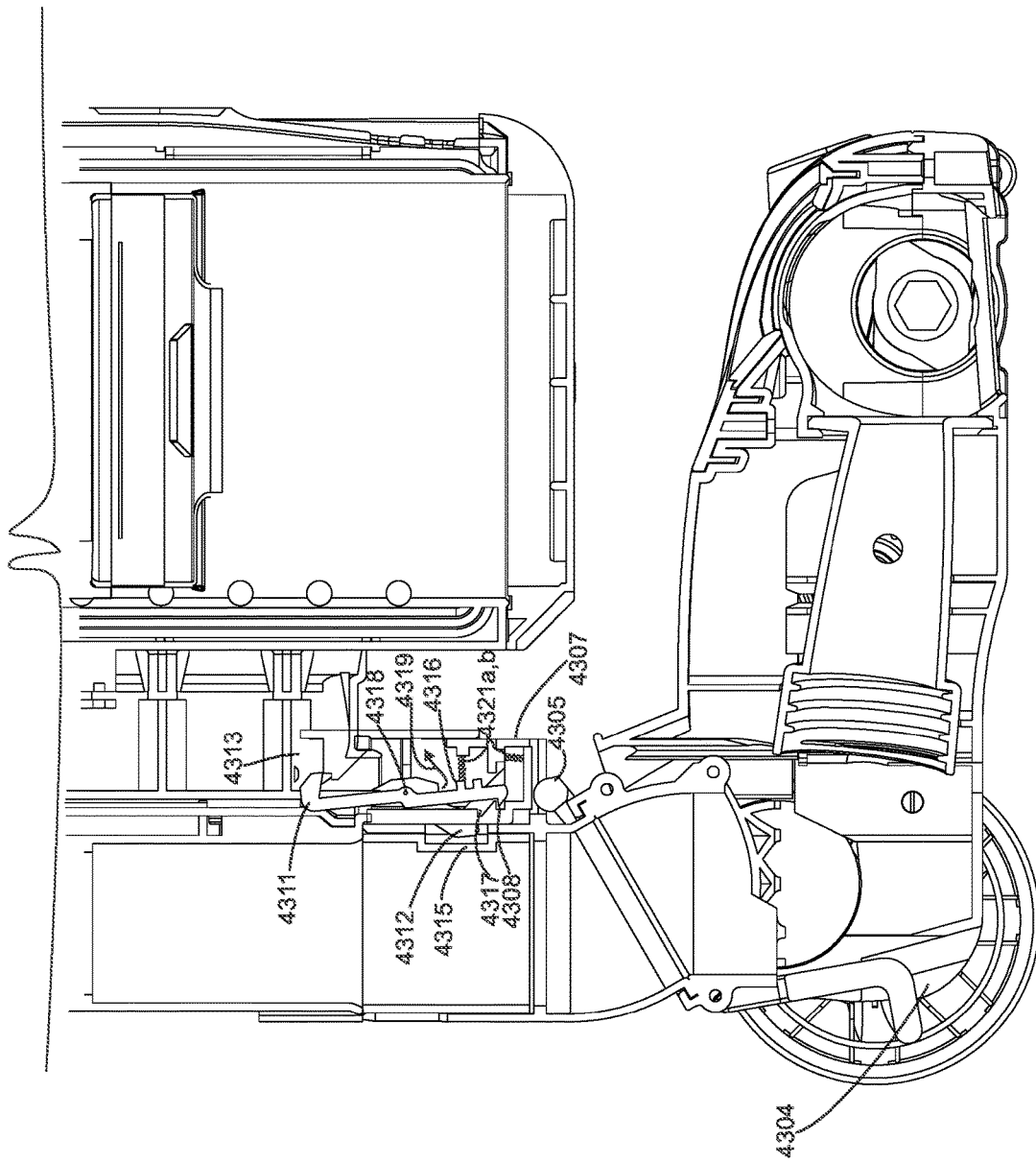

Fig. 41

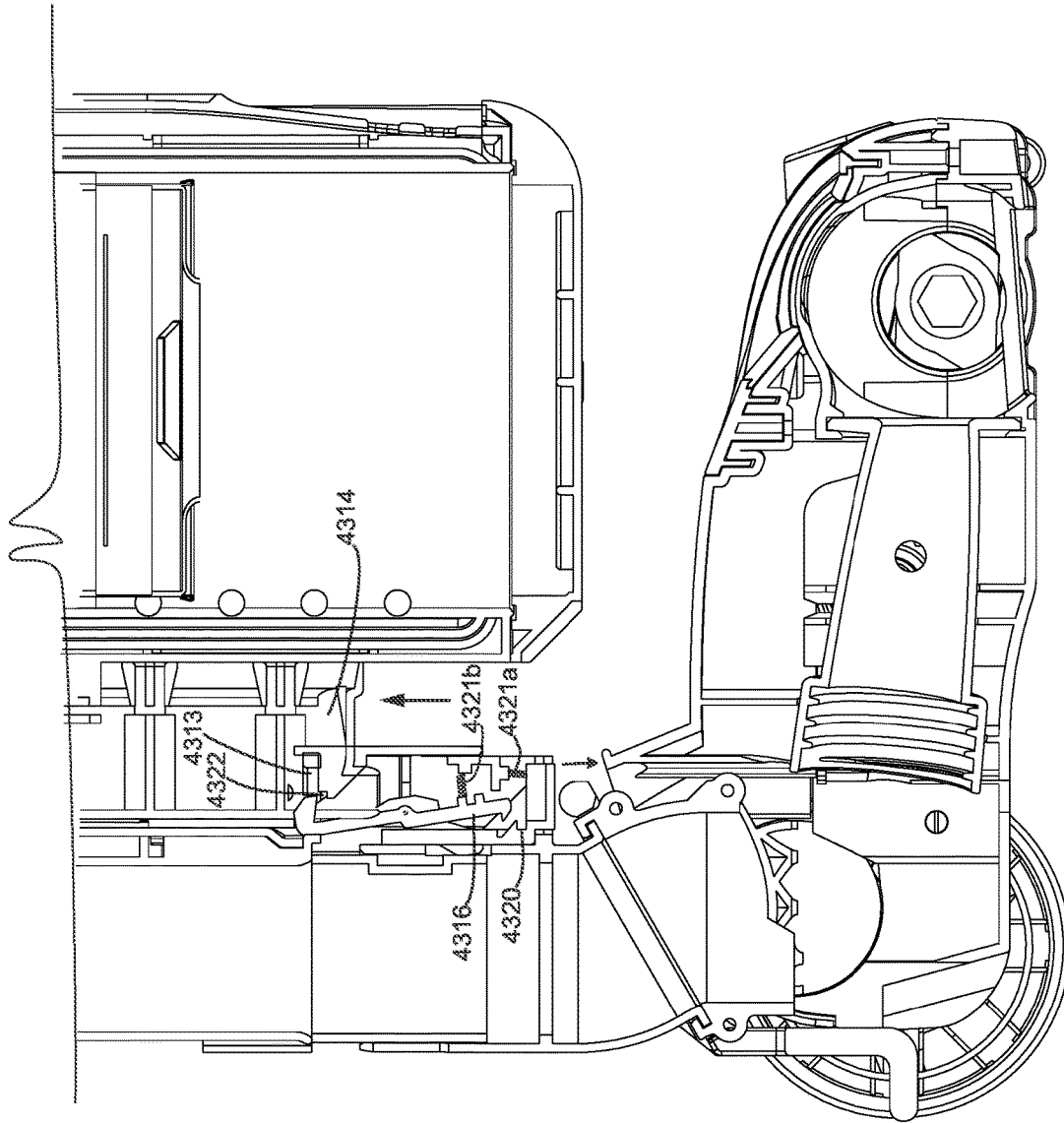

Fig. 42

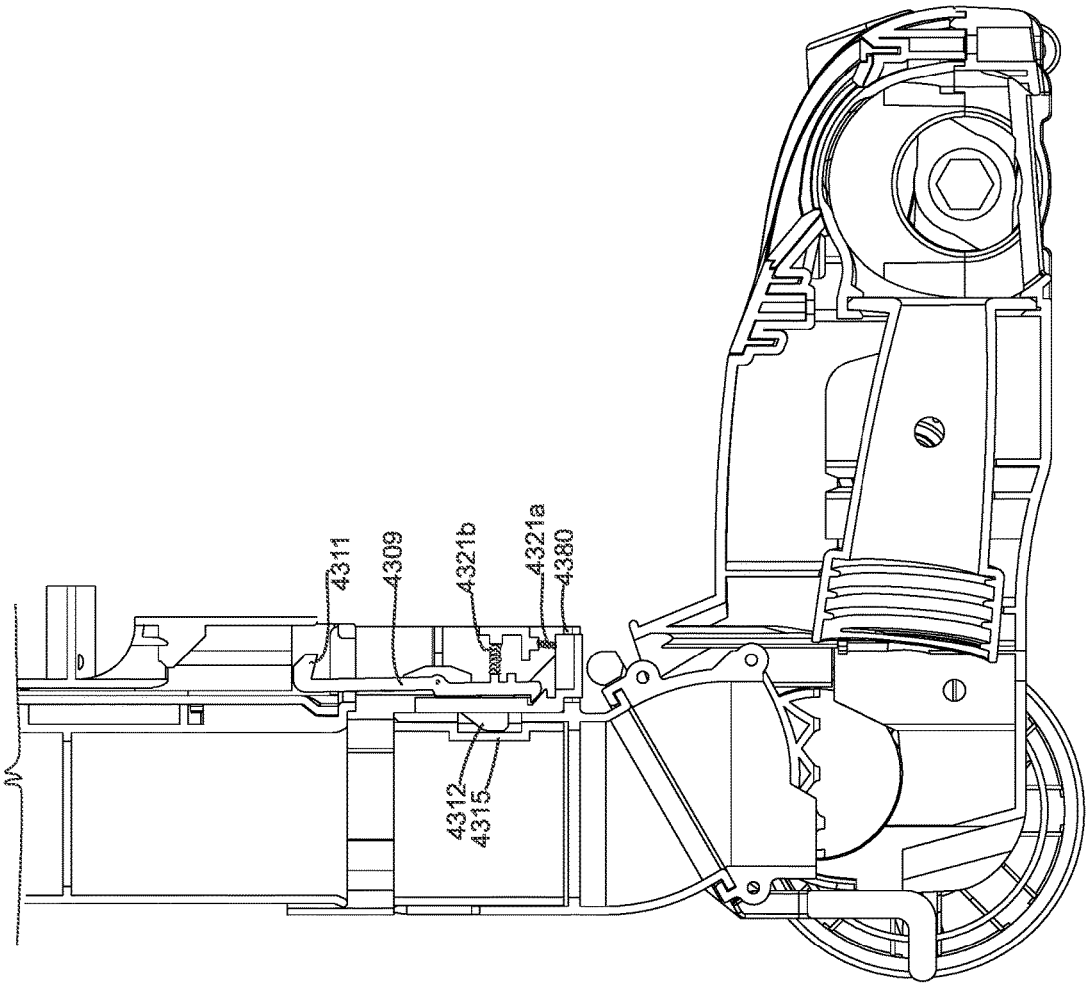

Fig. 43

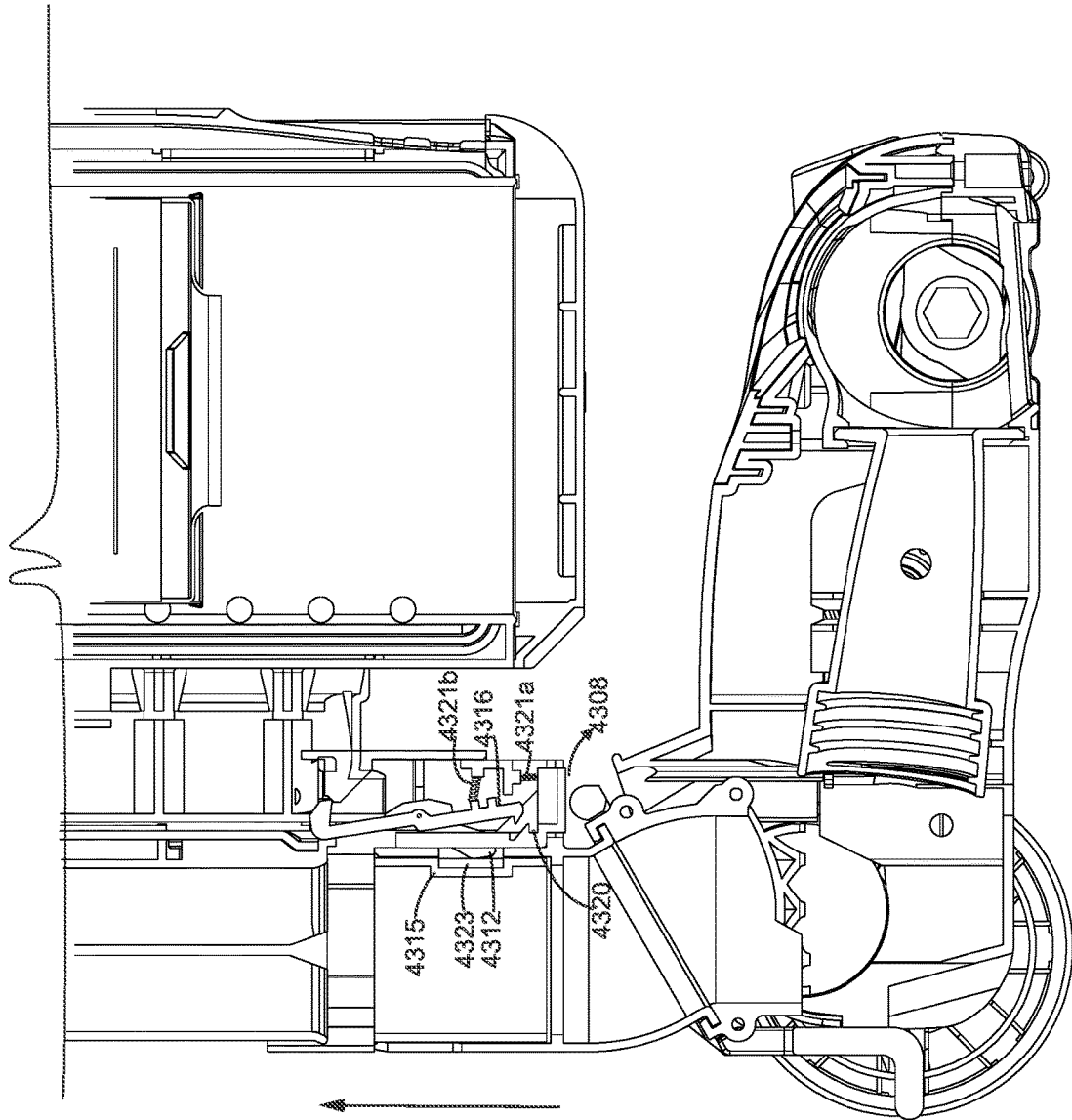

Fig. 44

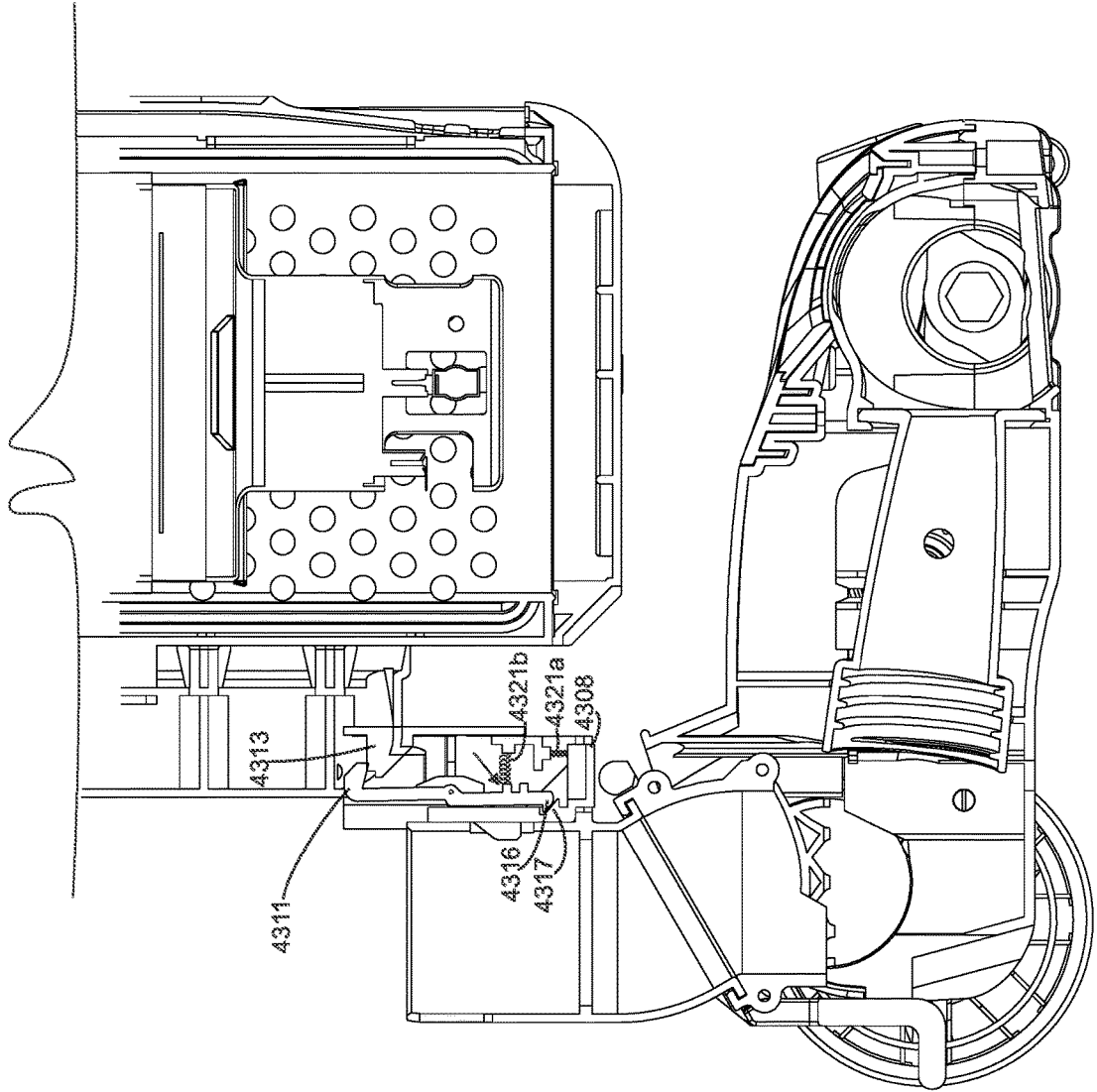

Fig. 45

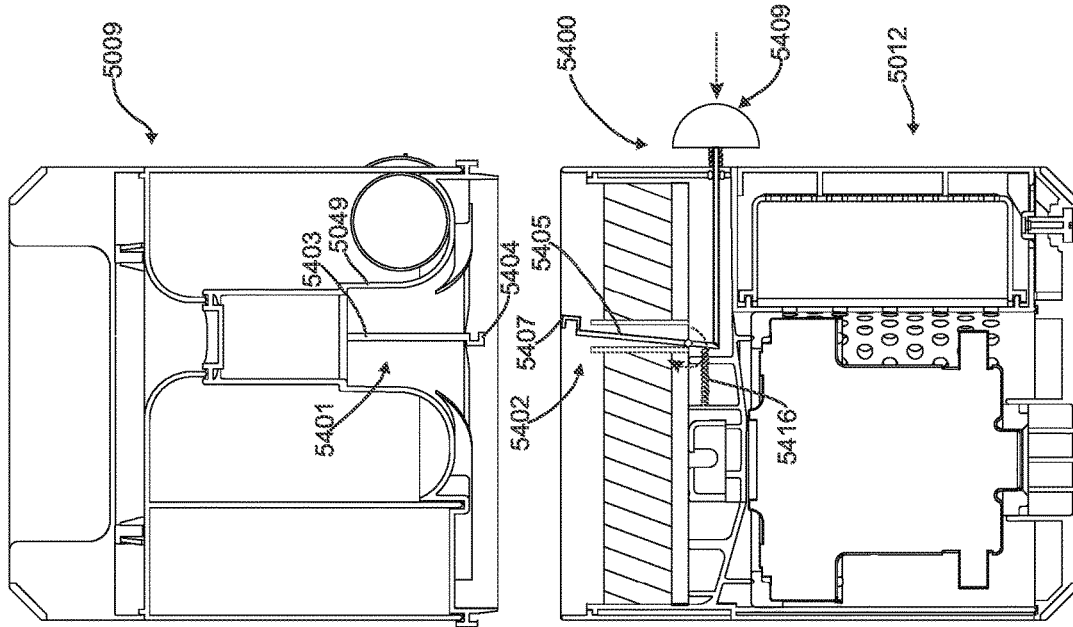

Fig. 46B

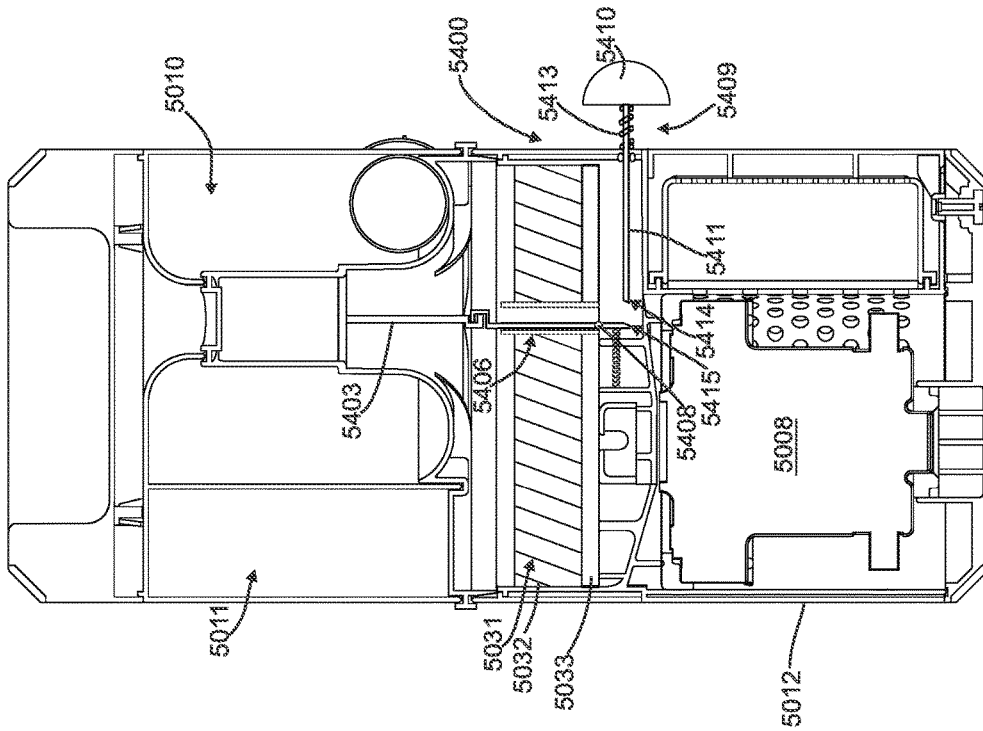

Fig. 46A

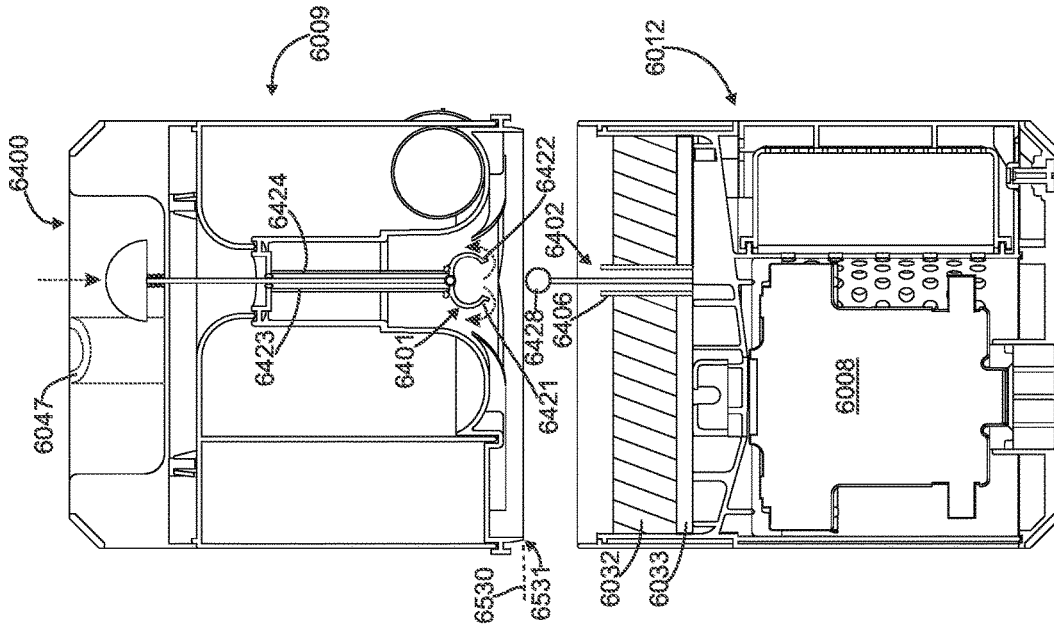

Fig. 47B

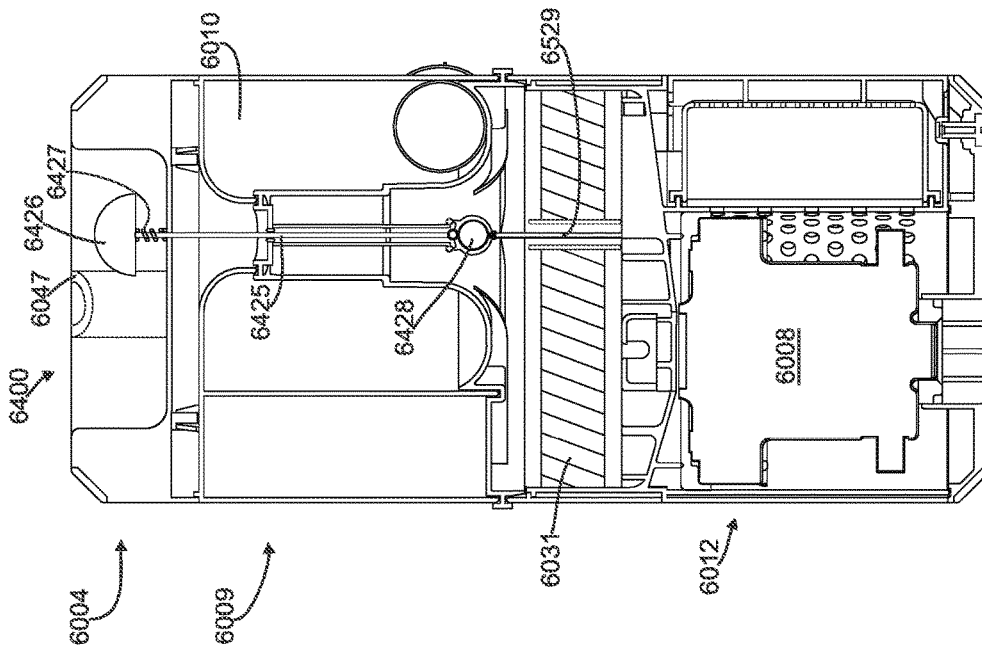

Fig. 47A

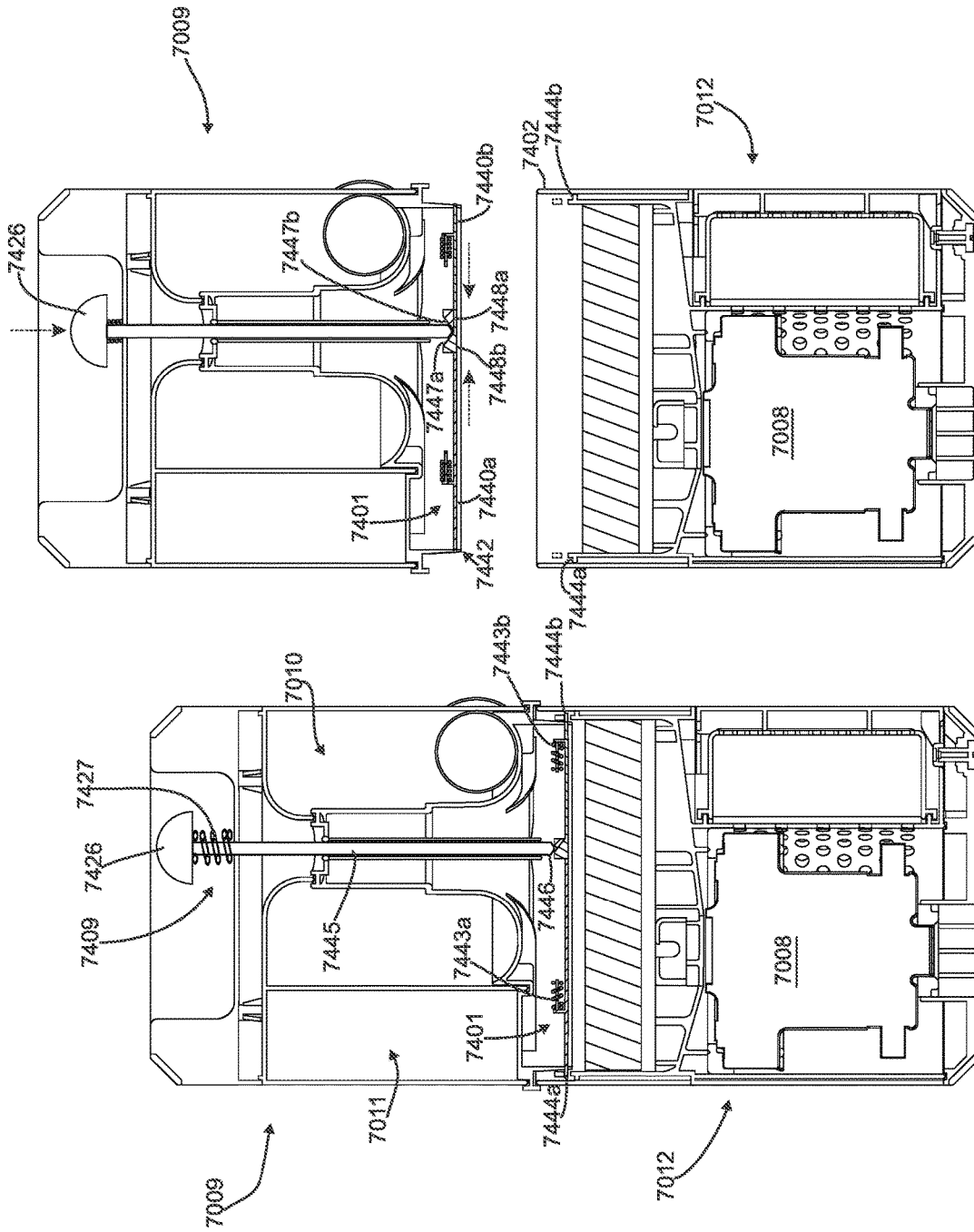

Fig. 48B

Fig. 48A

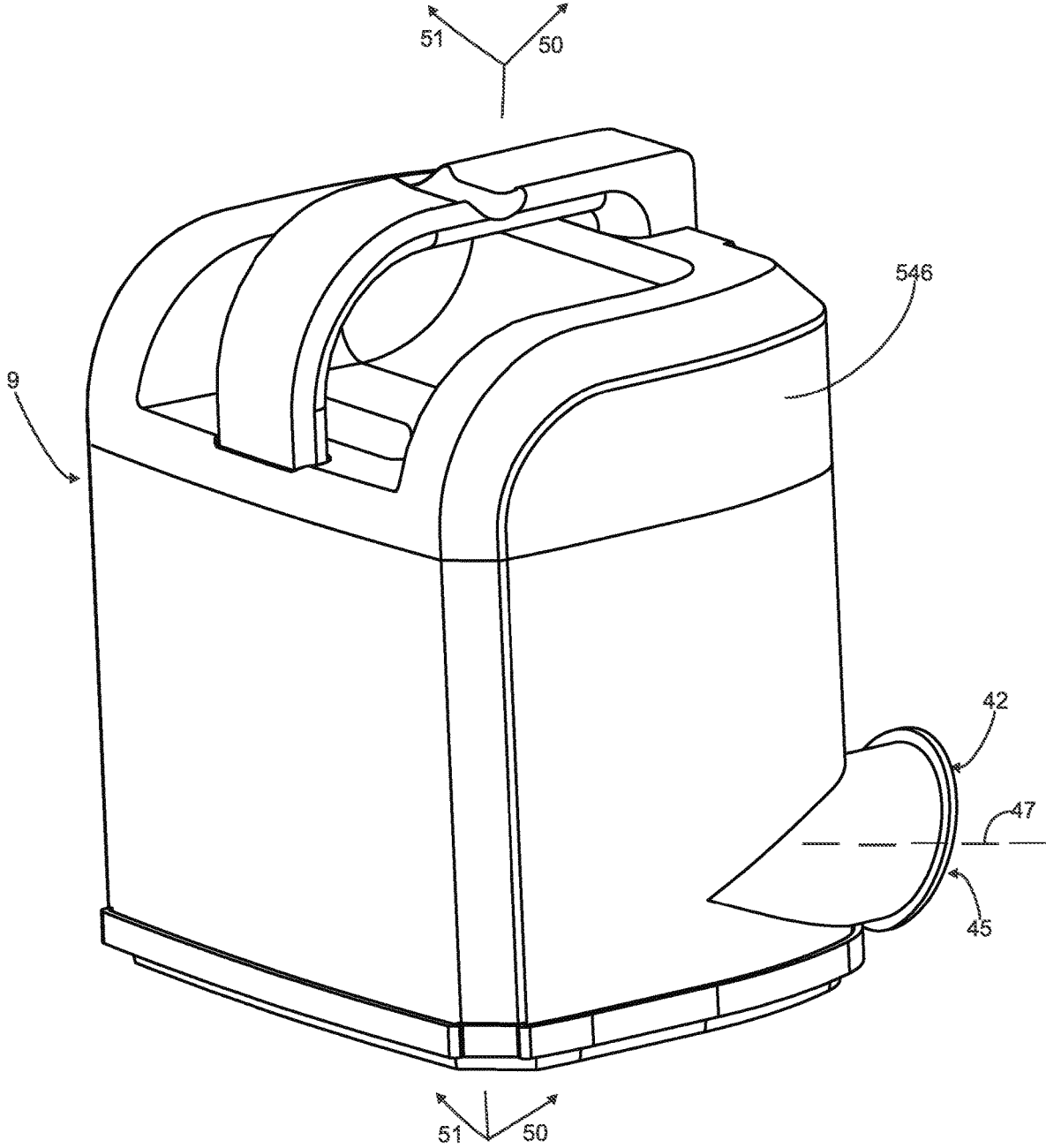

Fig. 49

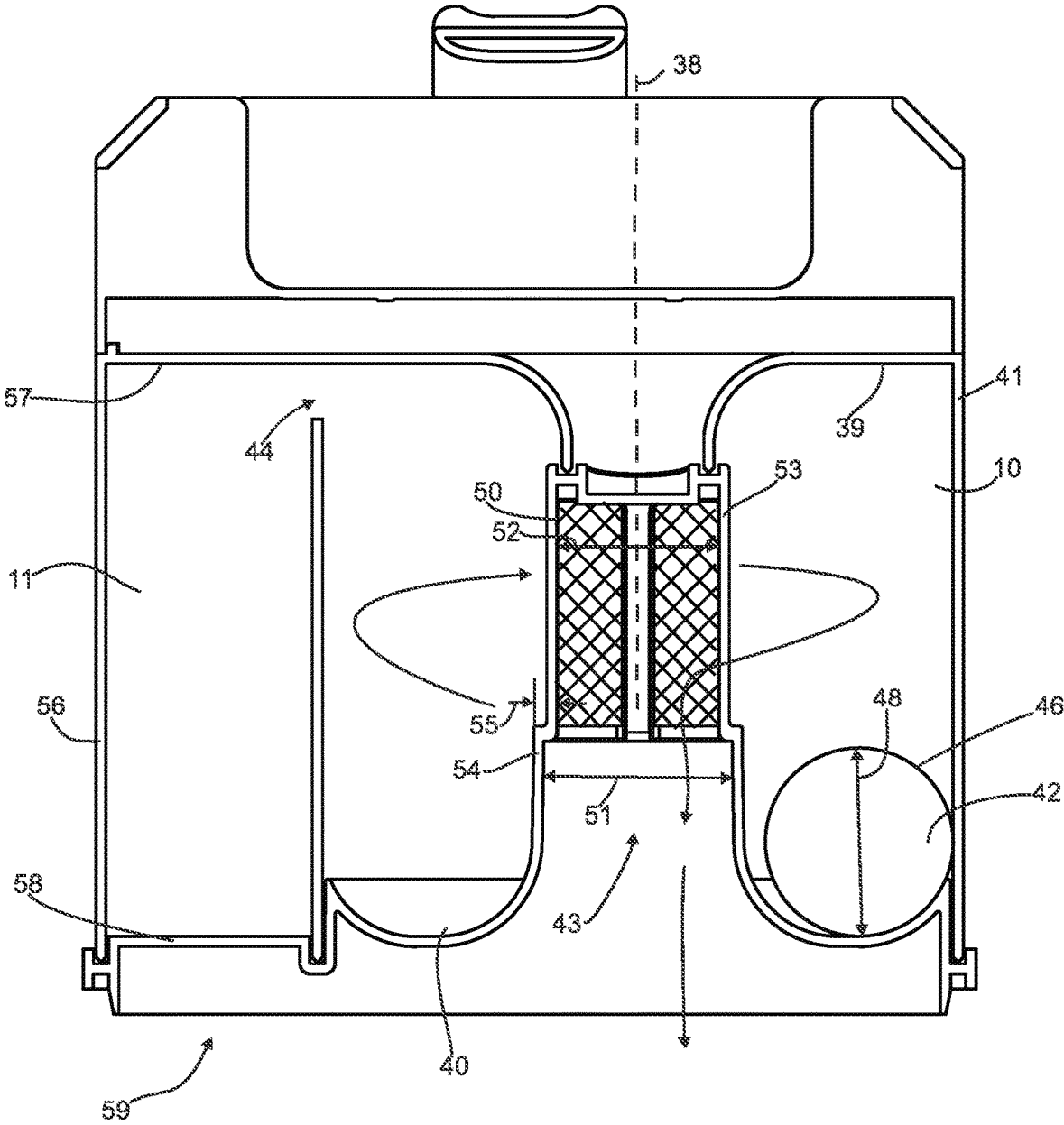

Fig. 50

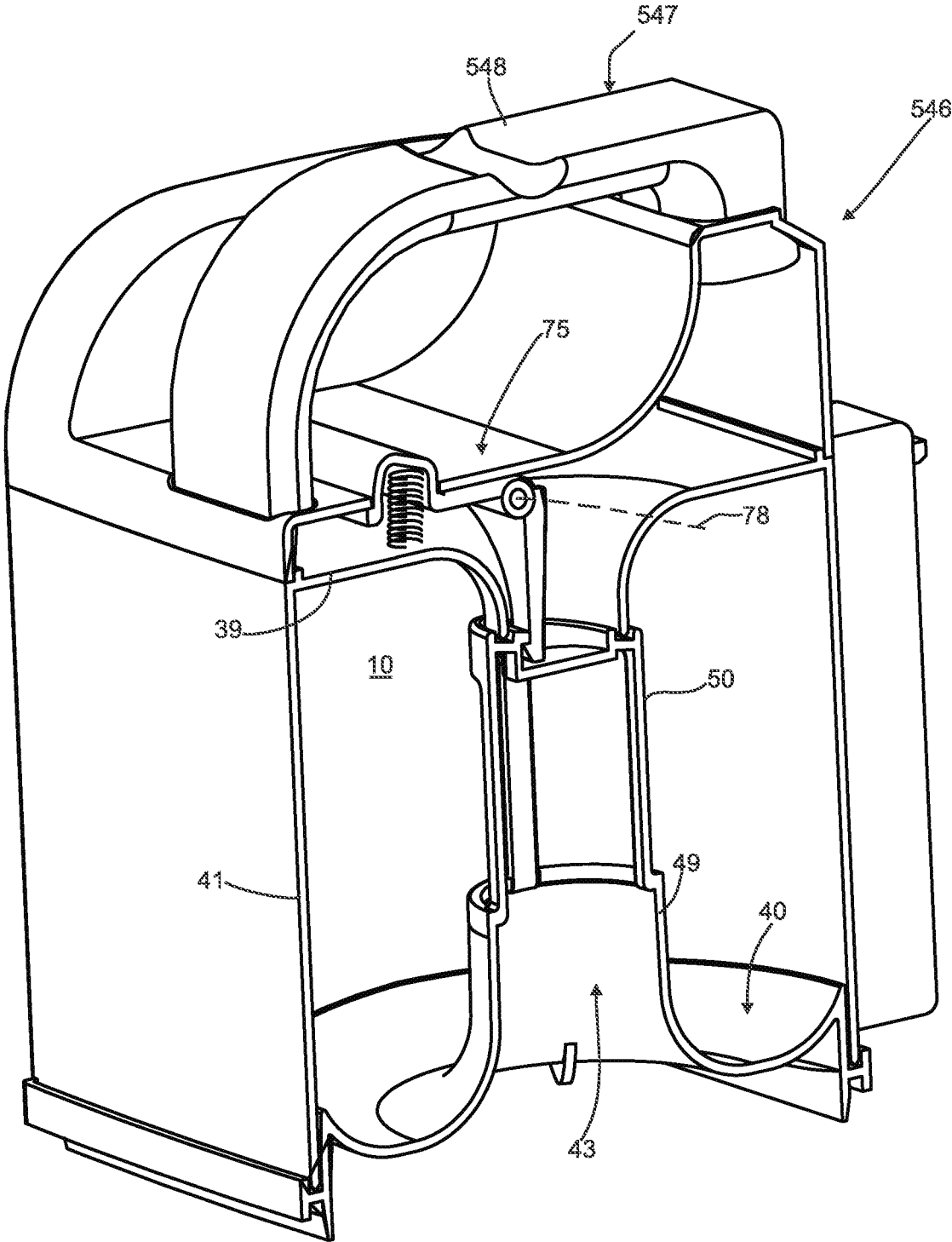

Fig. 51

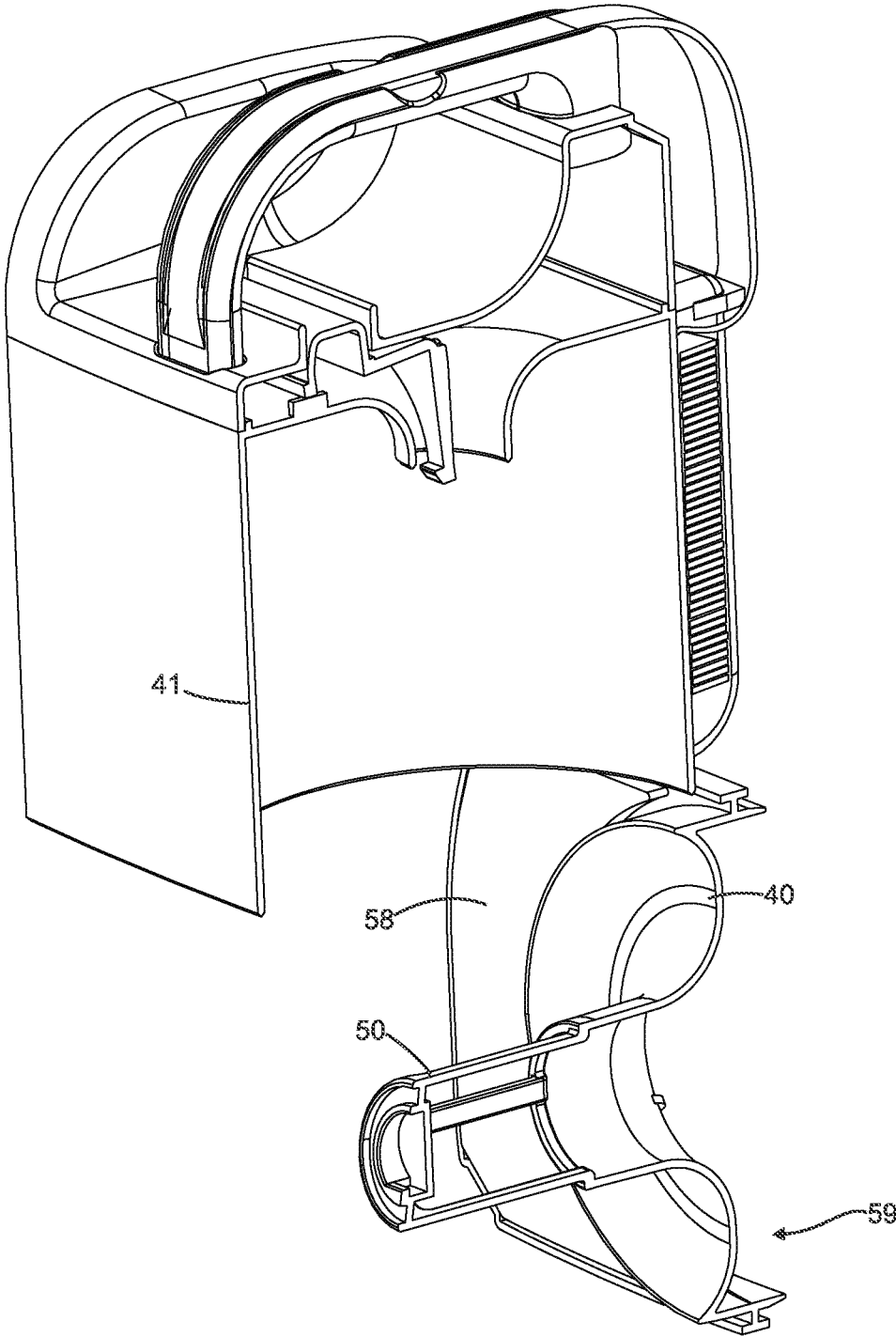

Fig. 52

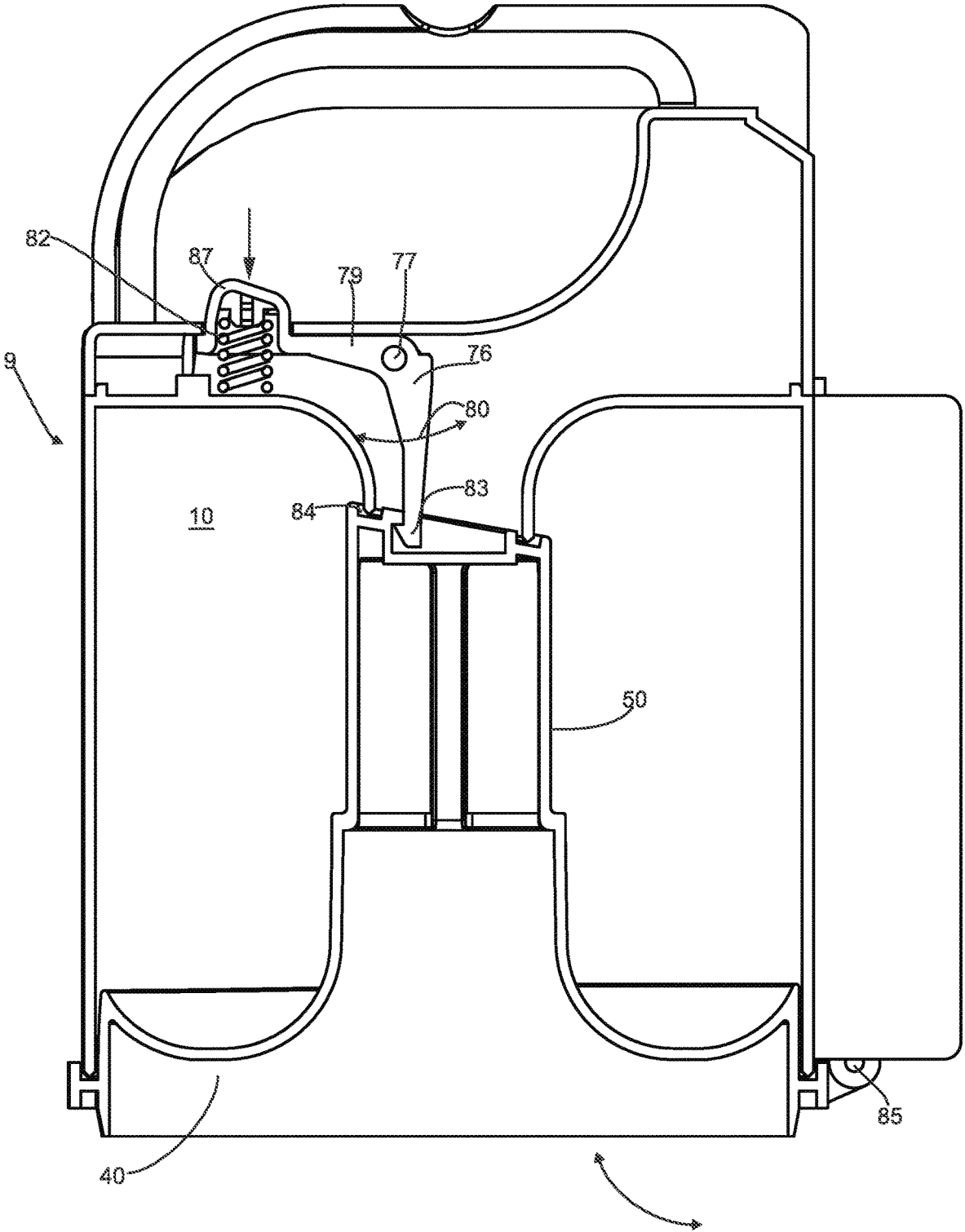

Fig. 53

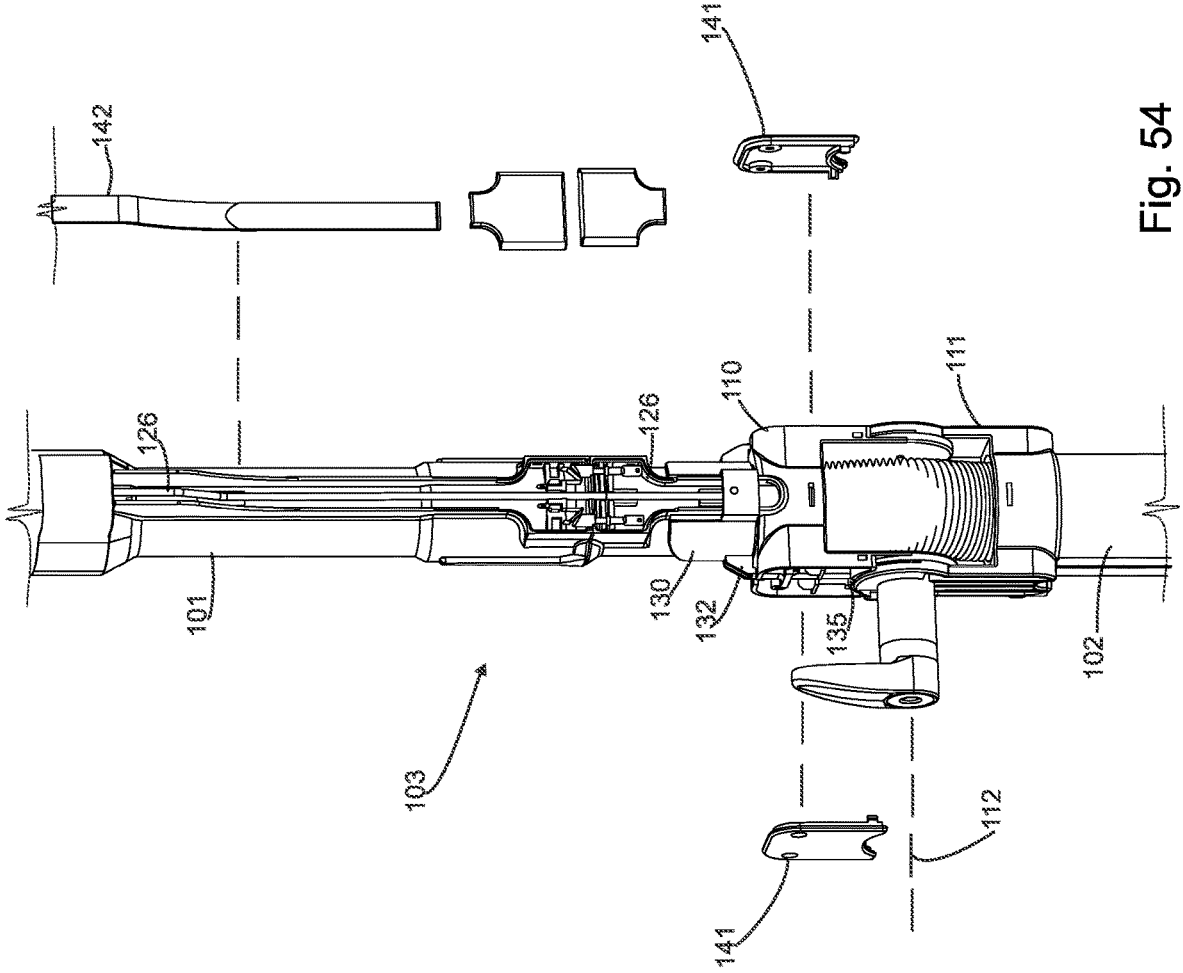

Fig. 54

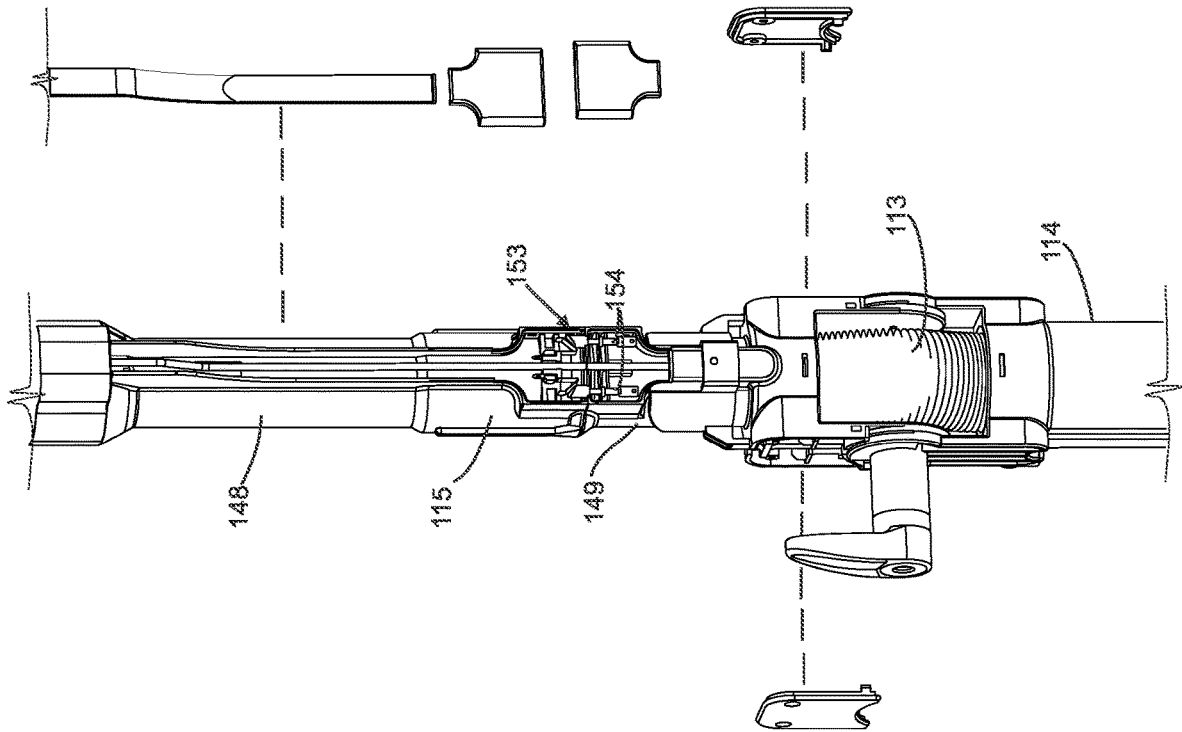

Fig. 55A

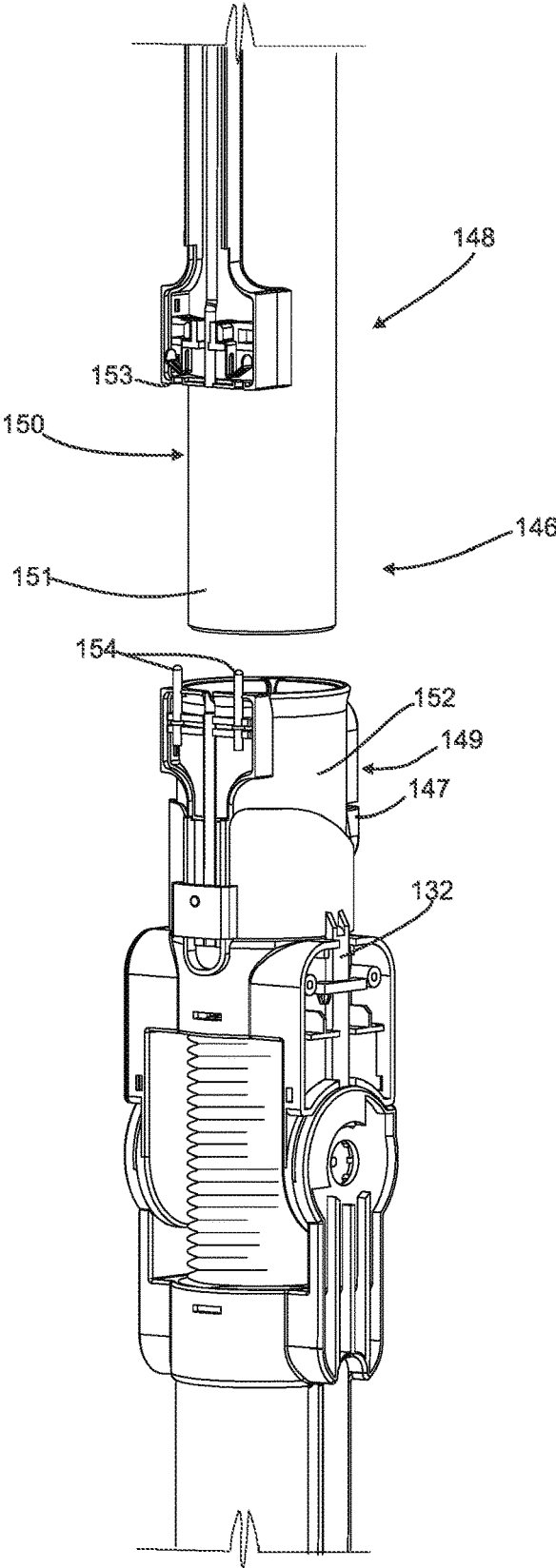

Fig. 55B

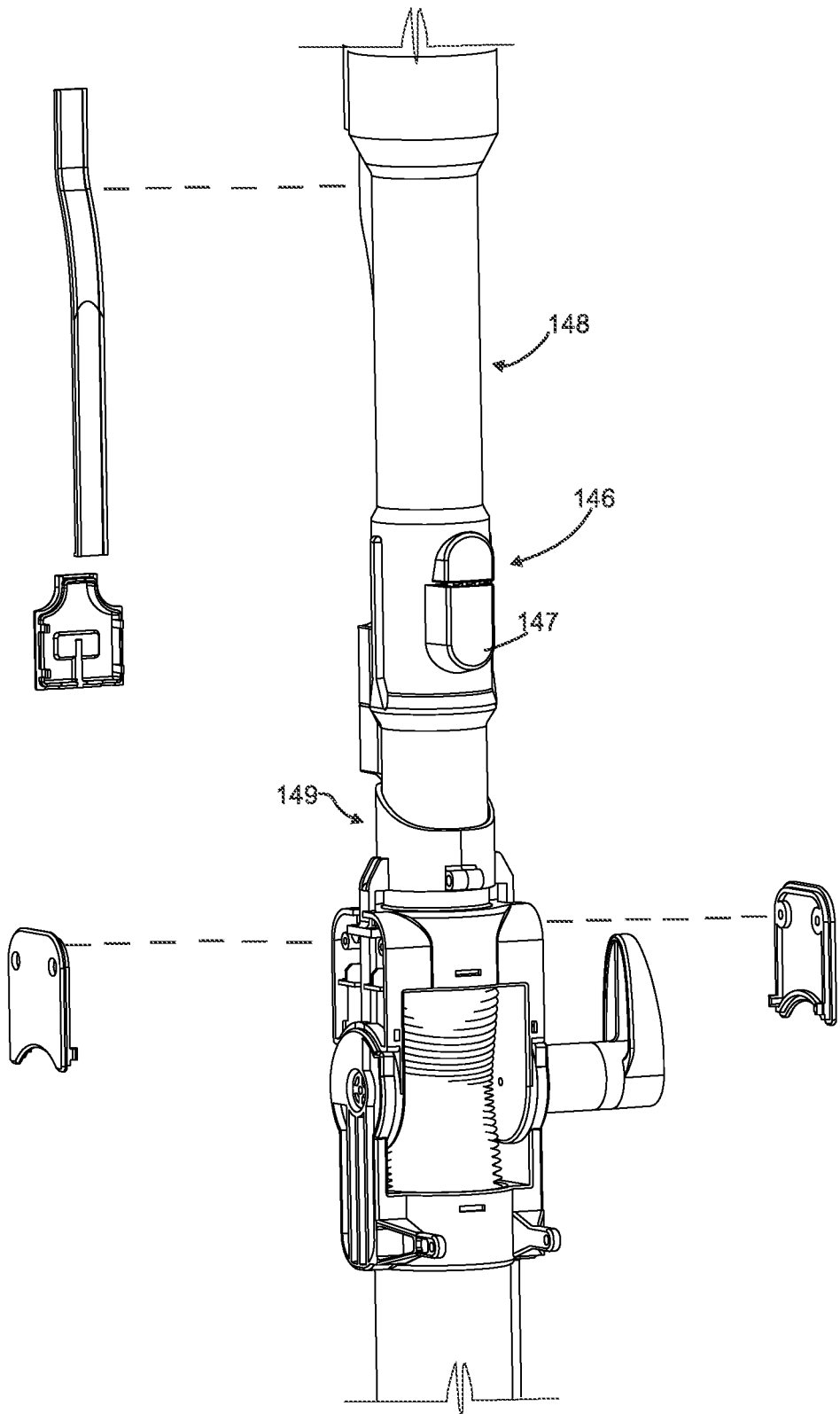

Fig. 56

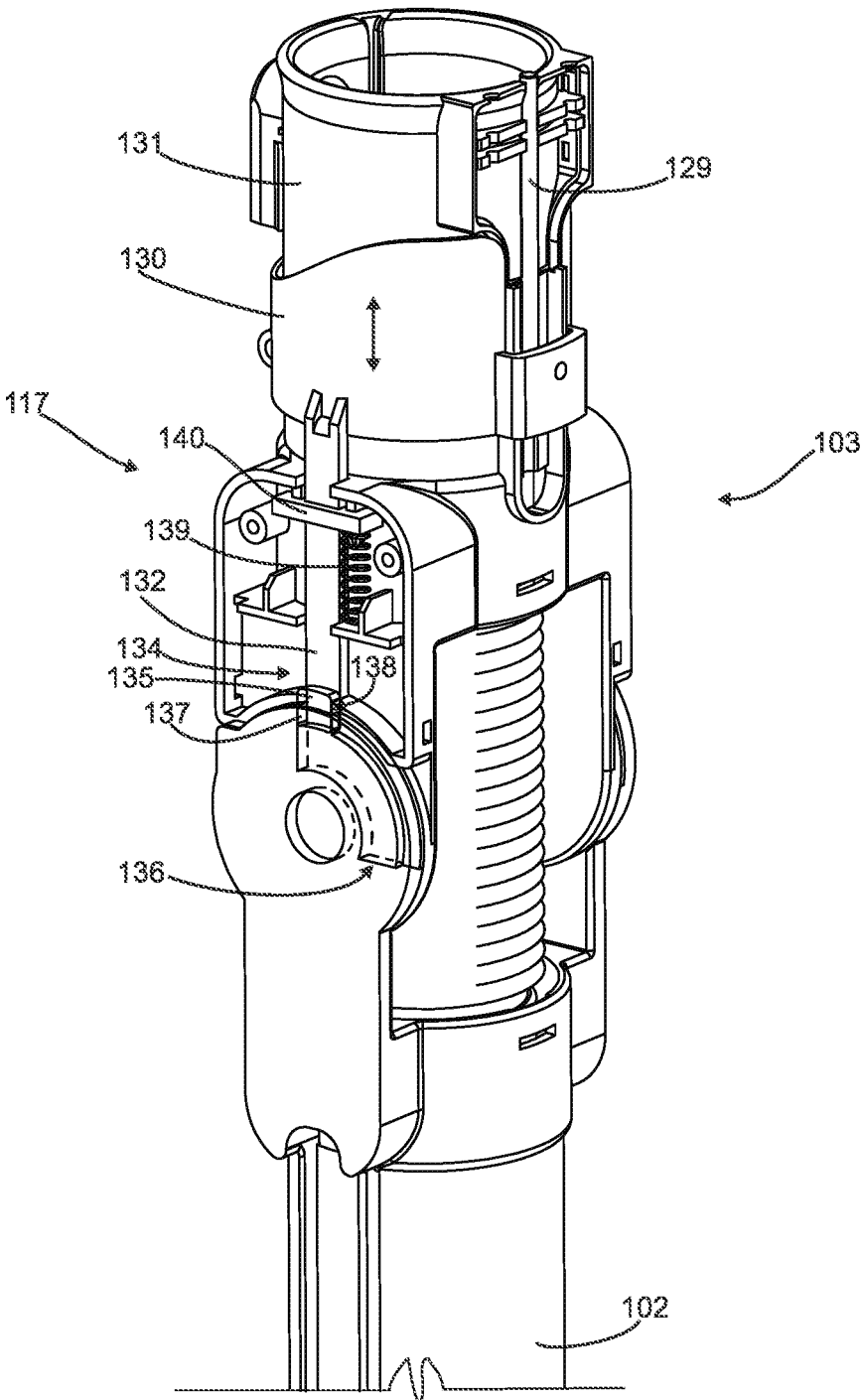

Fig. 57

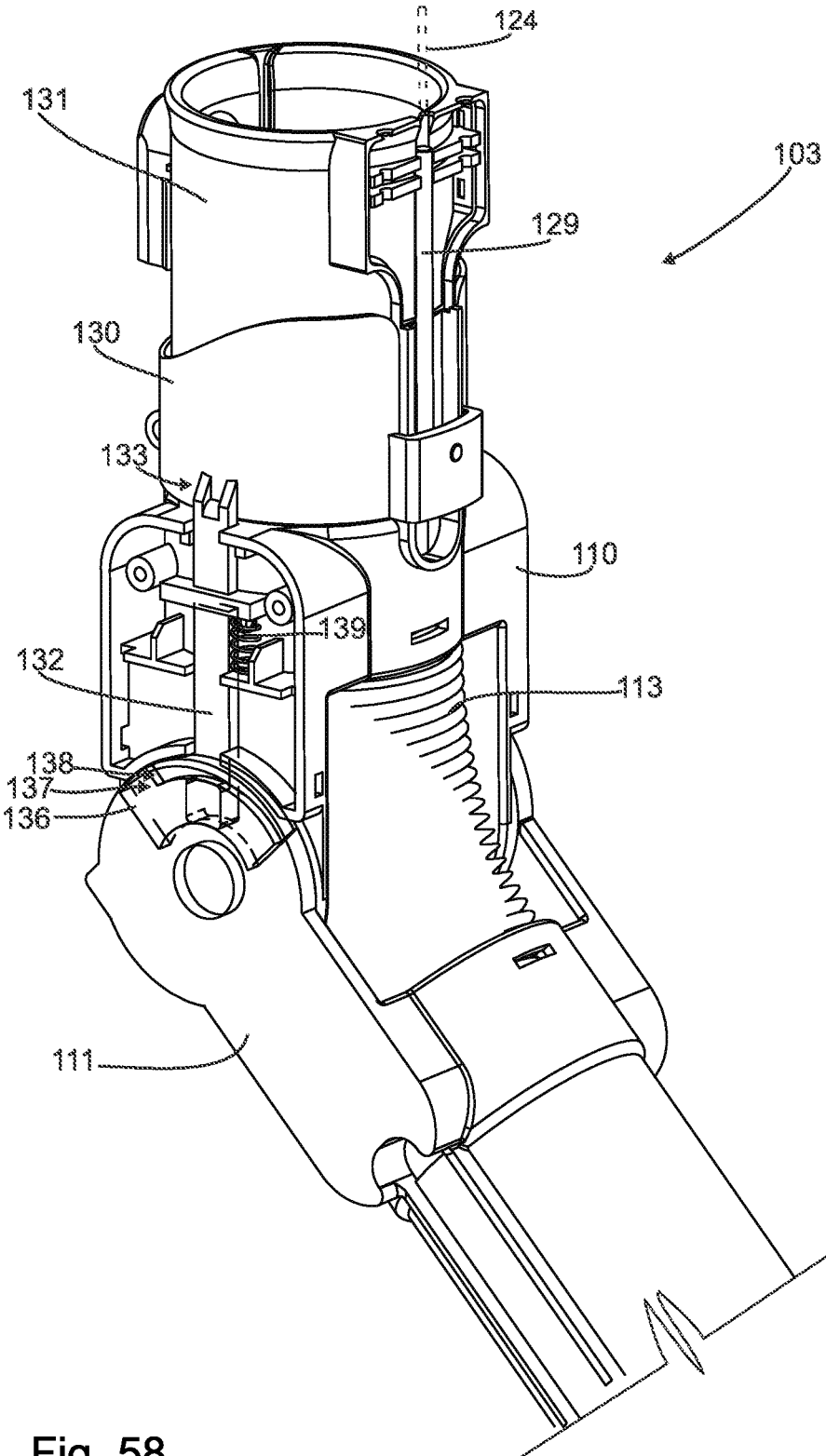

Fig. 58

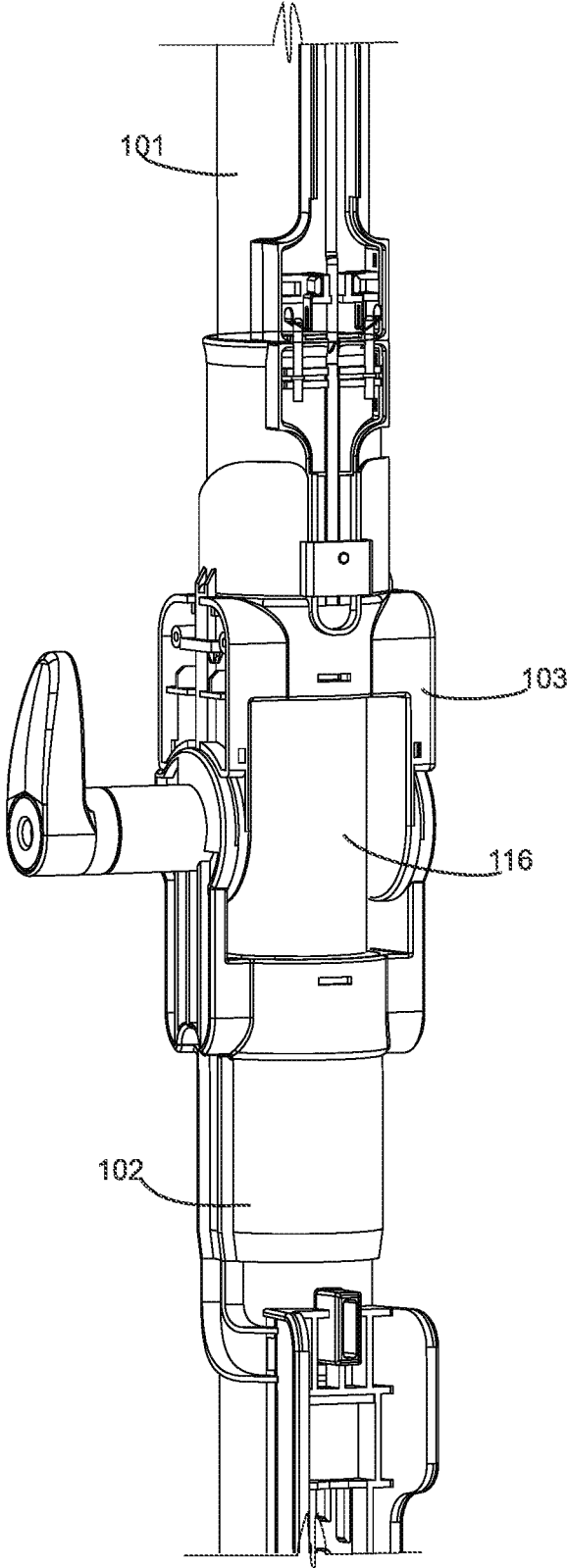

Fig. 59

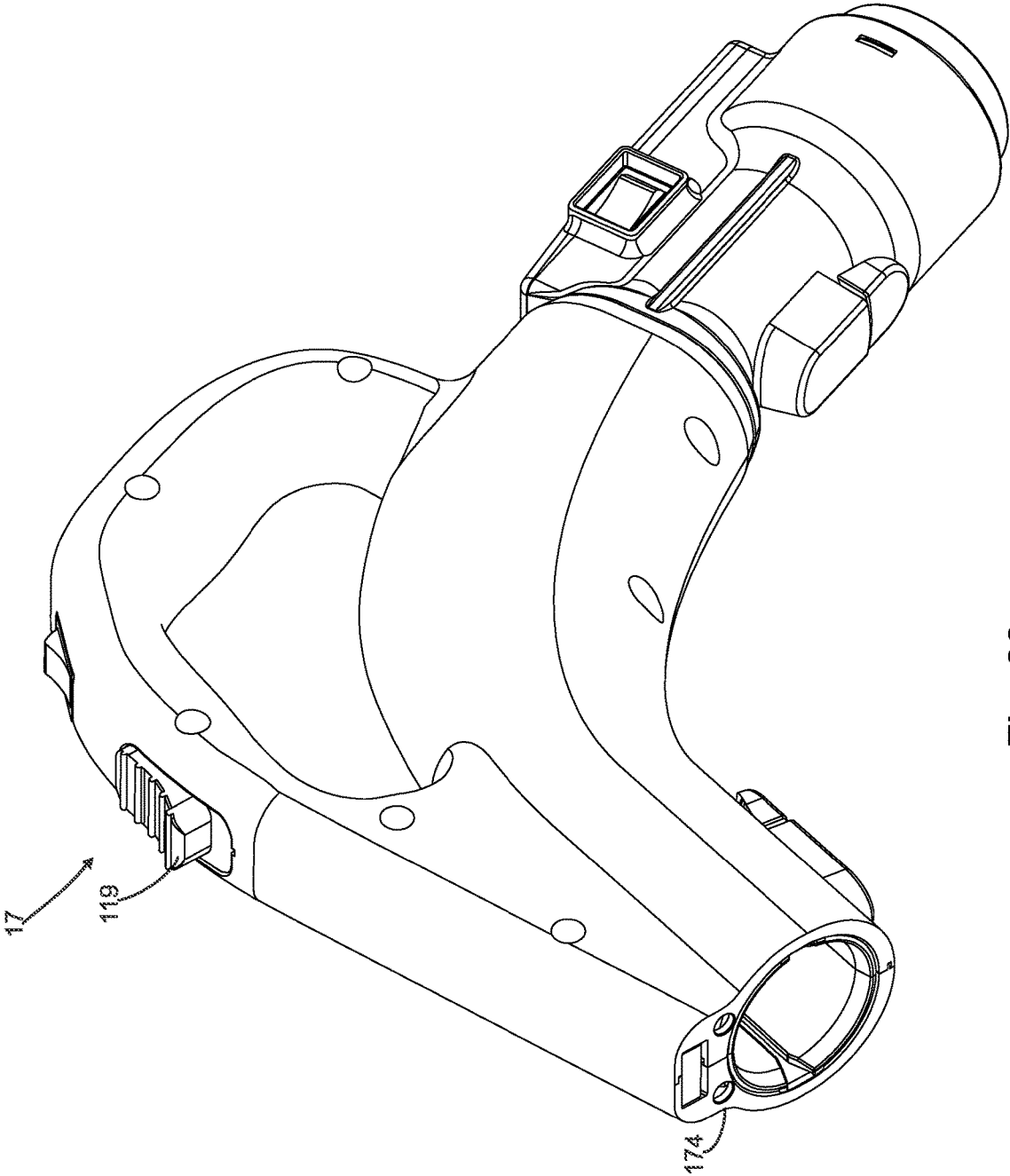

Fig. 60

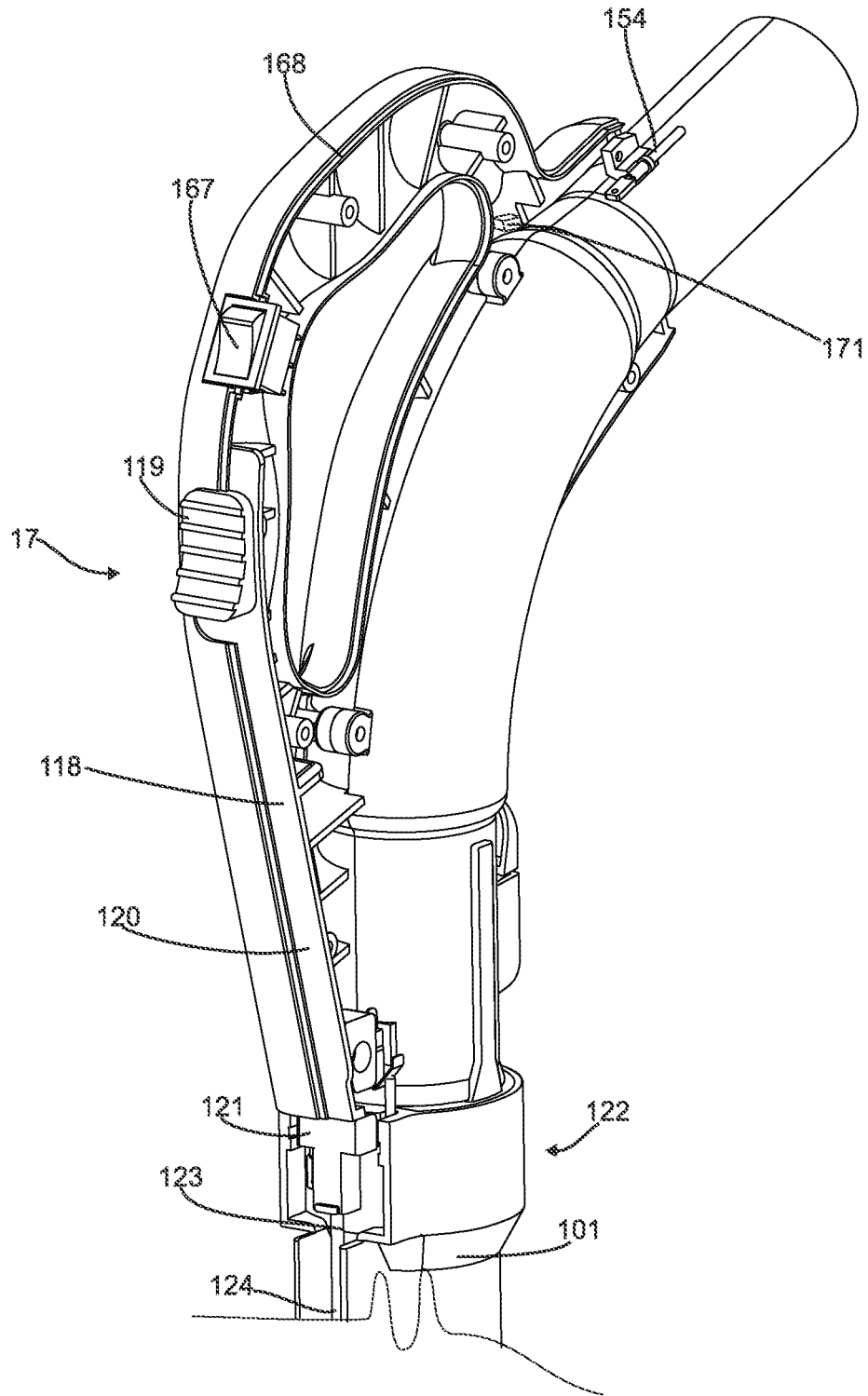

Fig. 61

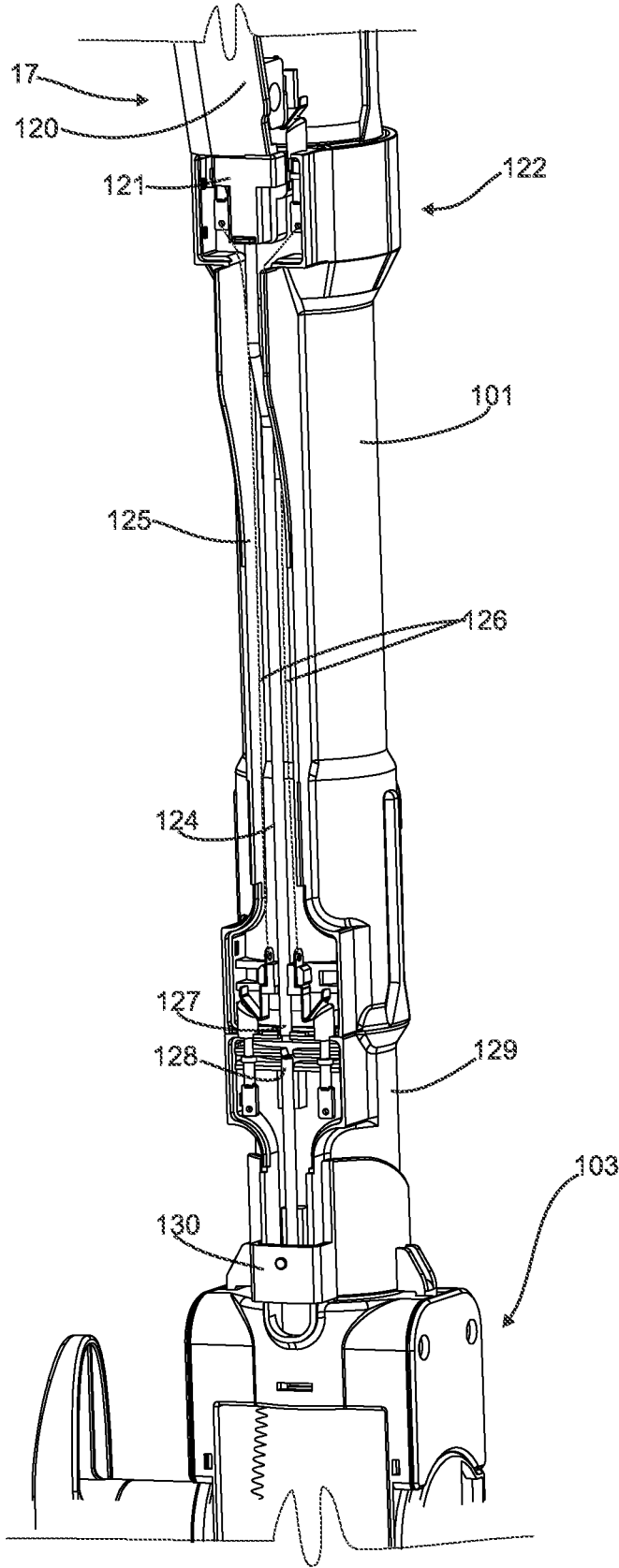

Fig. 62

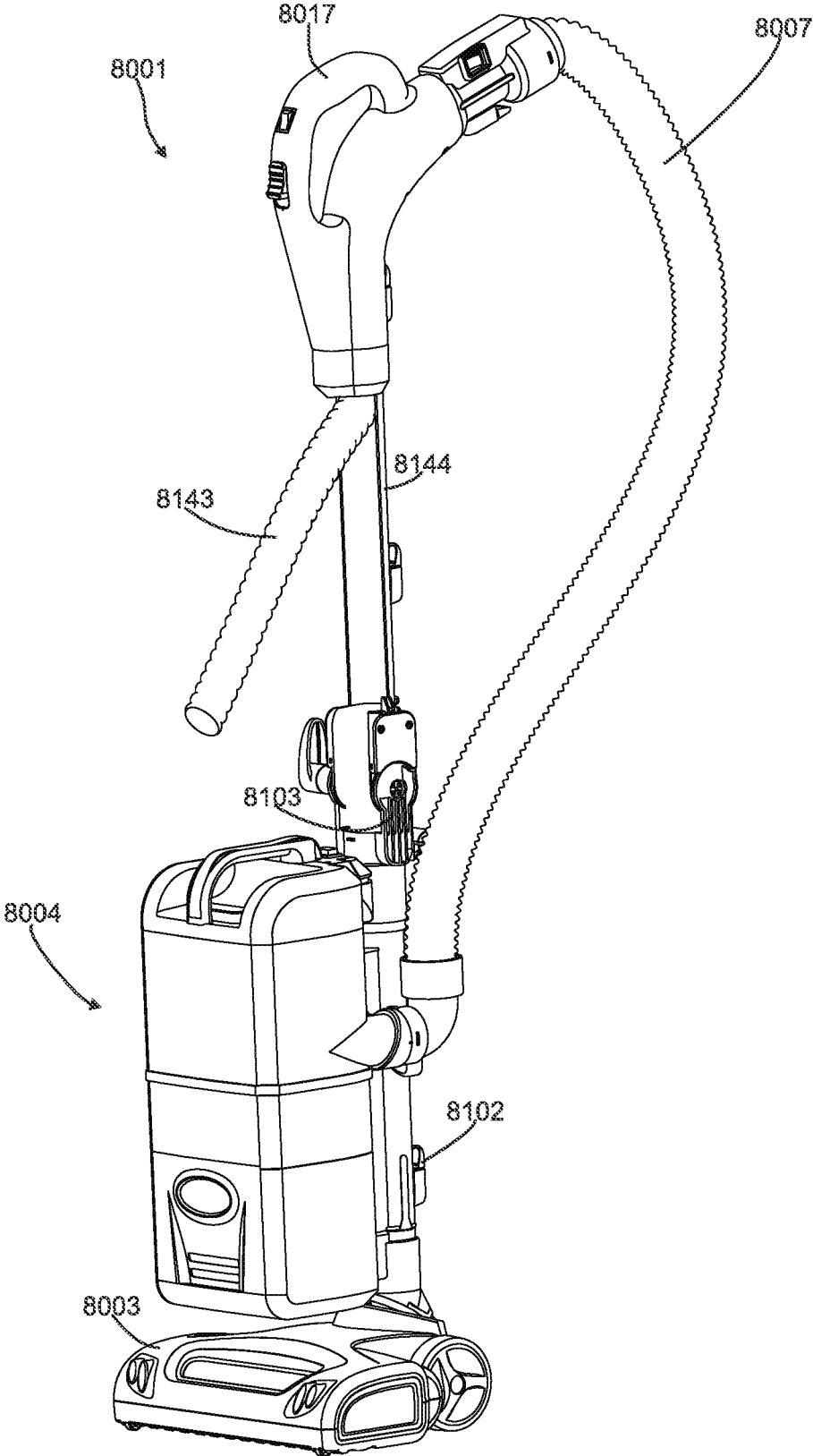

Fig. 63

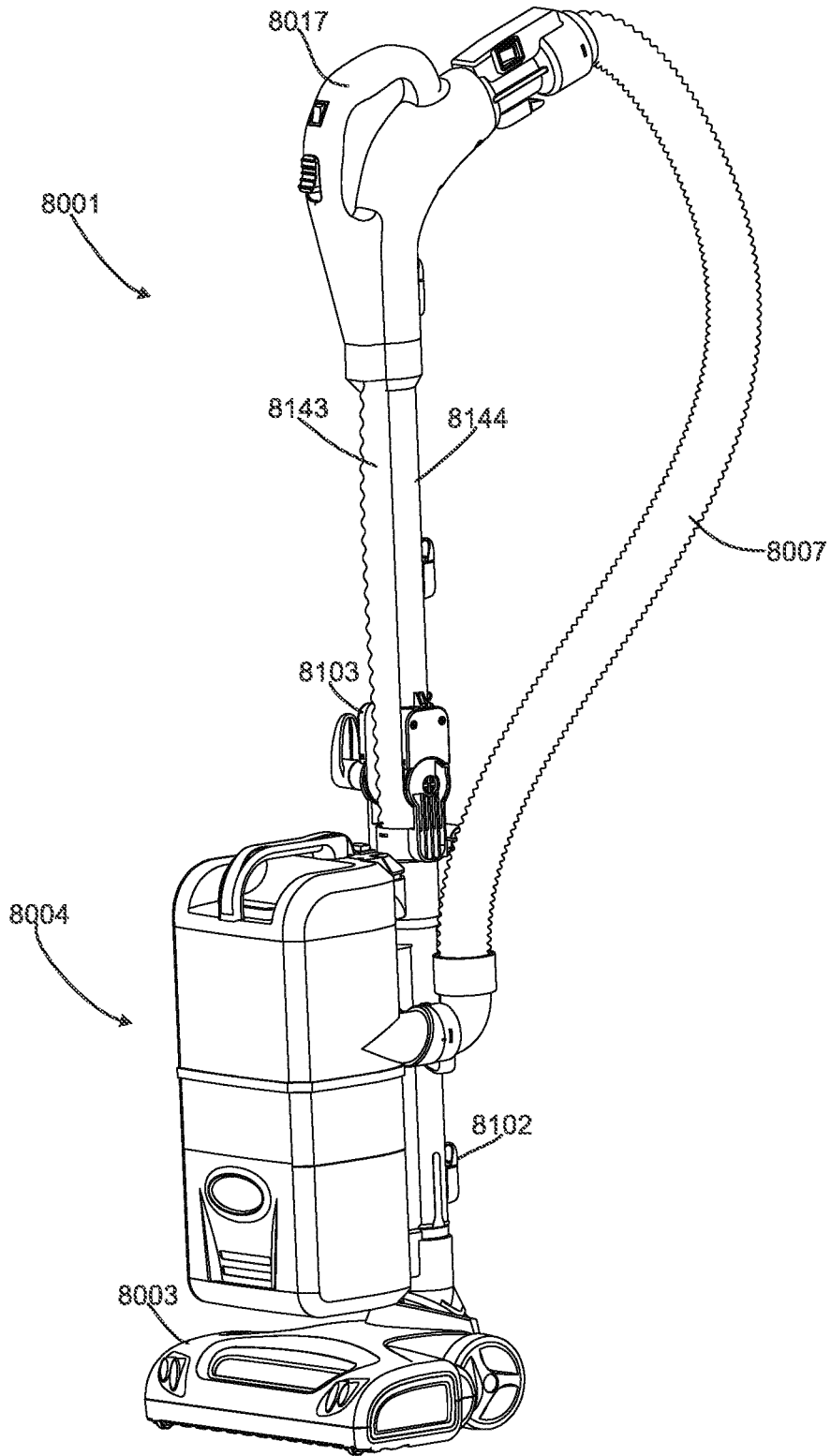

Fig. 64

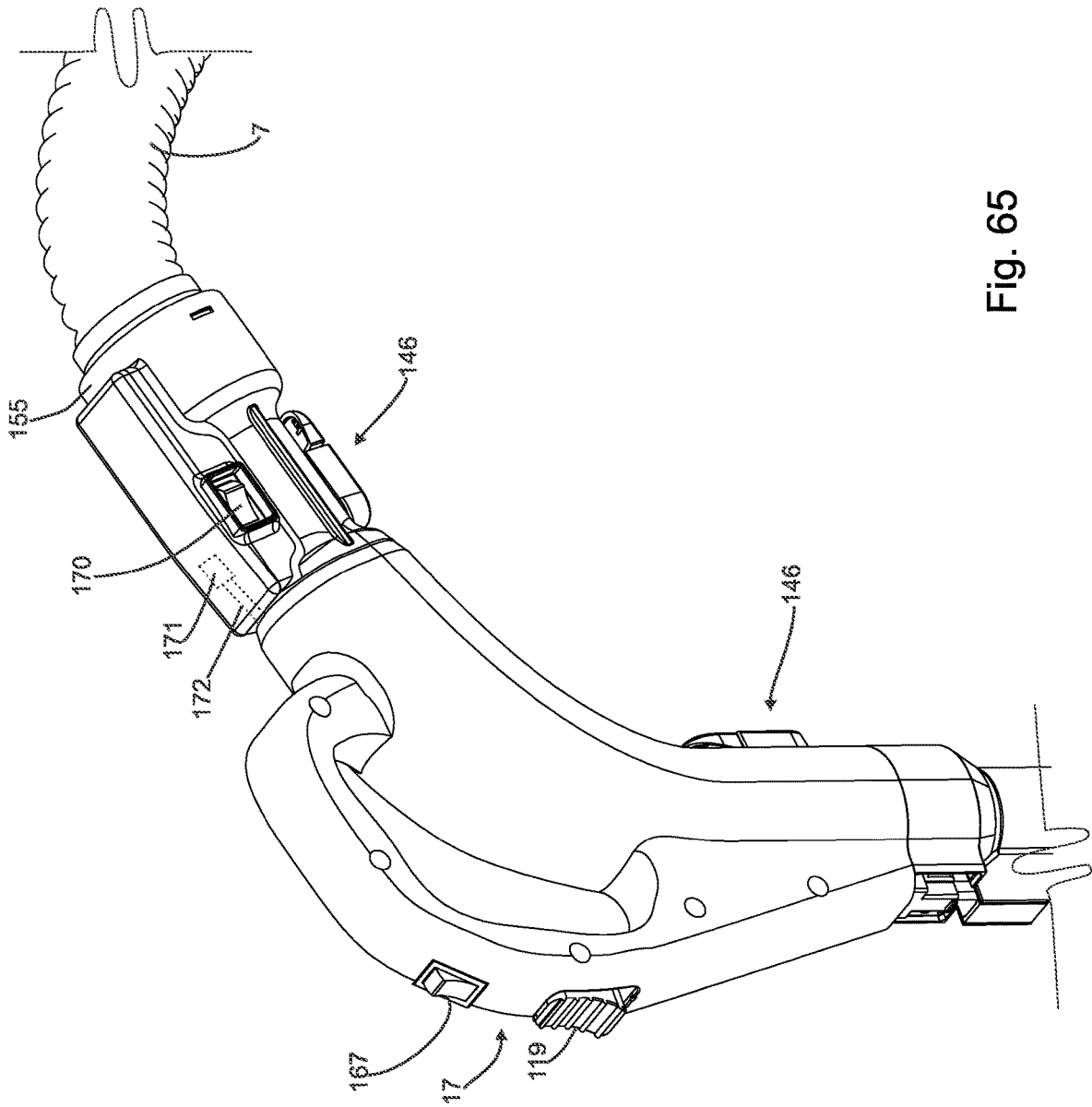

Fig. 65

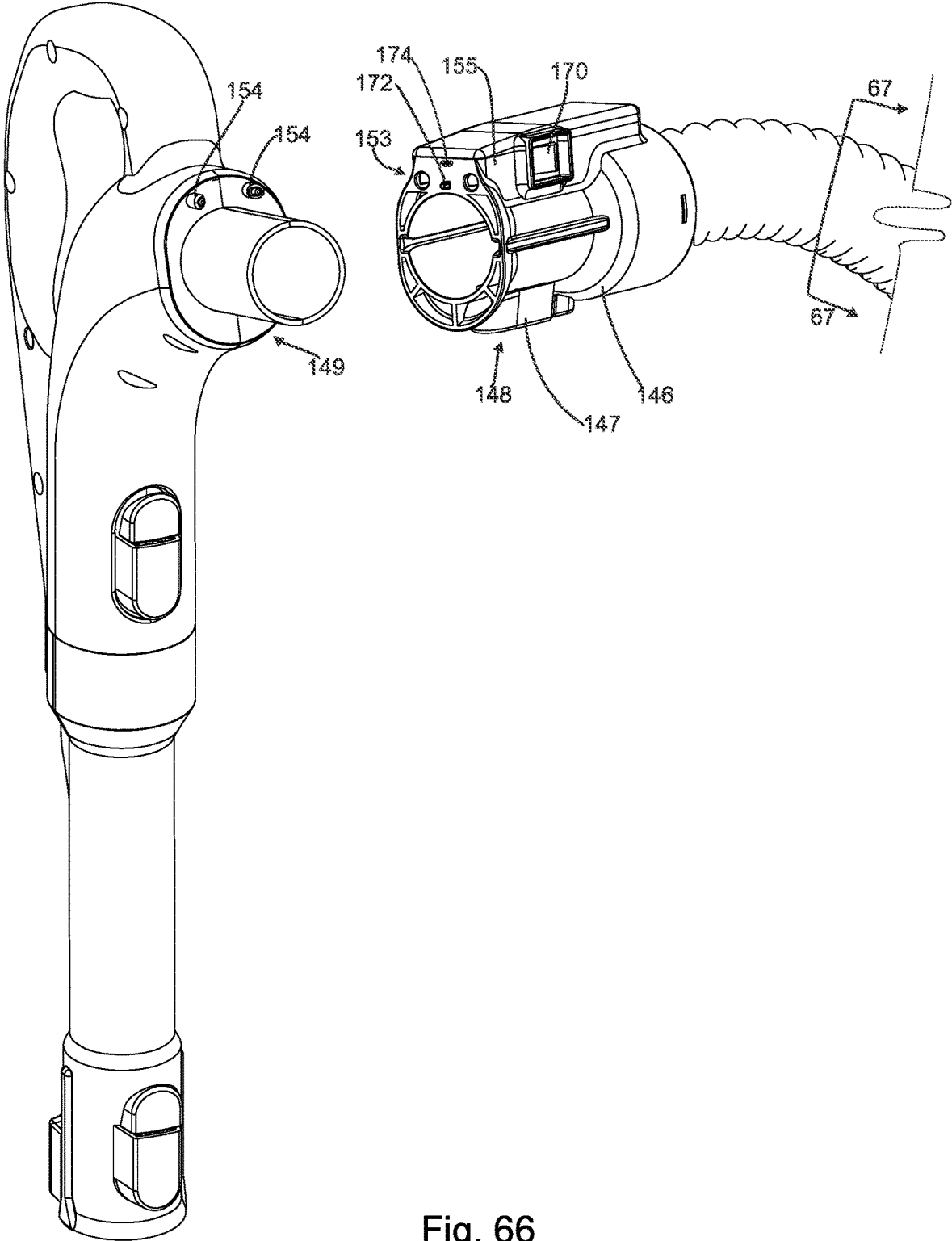

Fig. 66

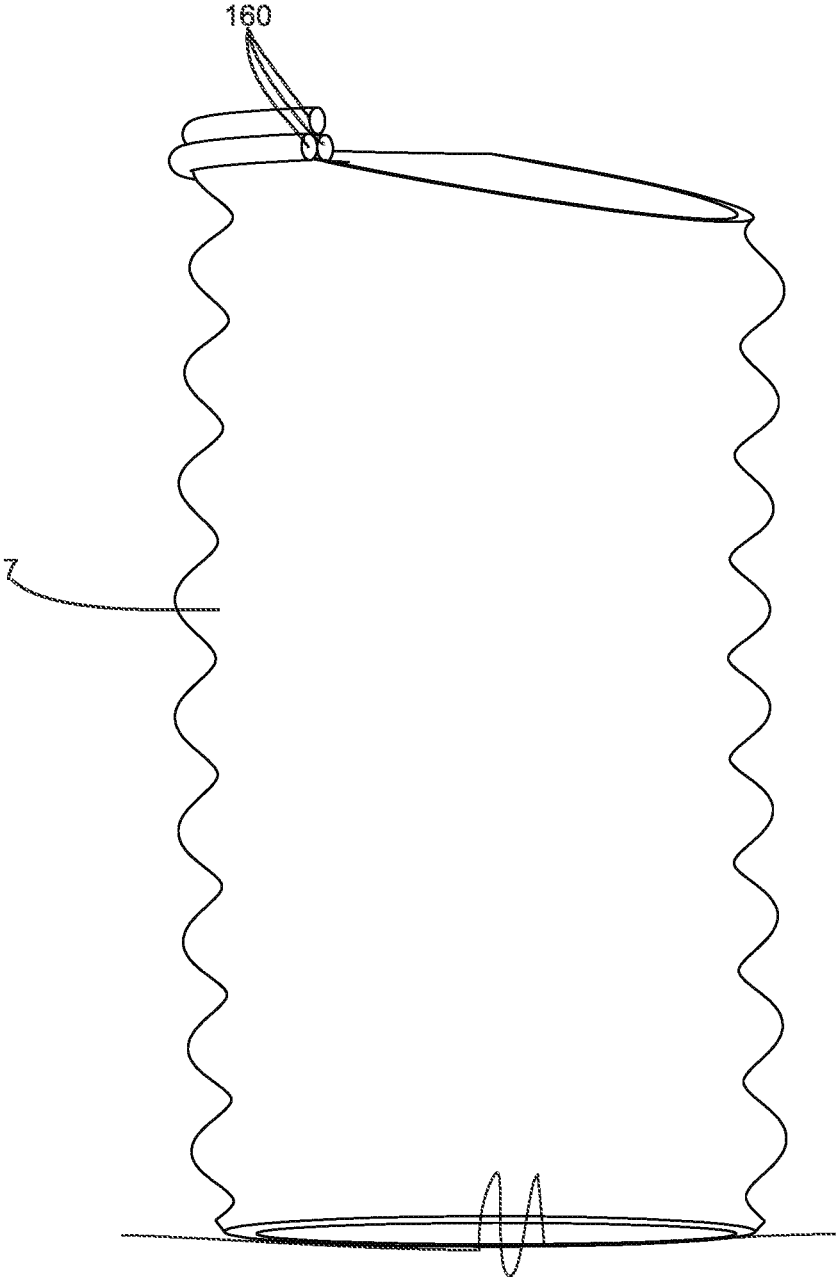

Fig. 67

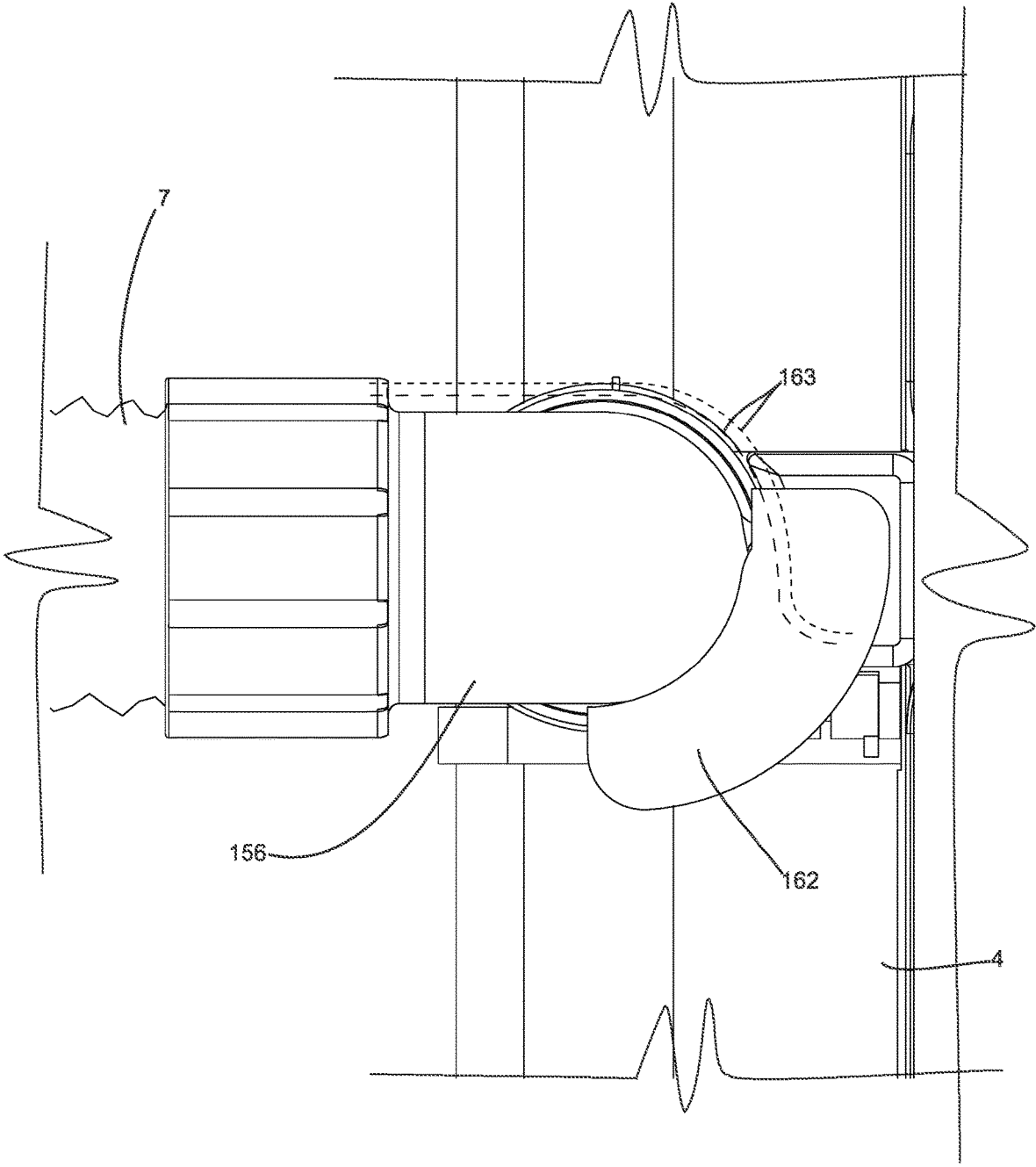

Fig. 68

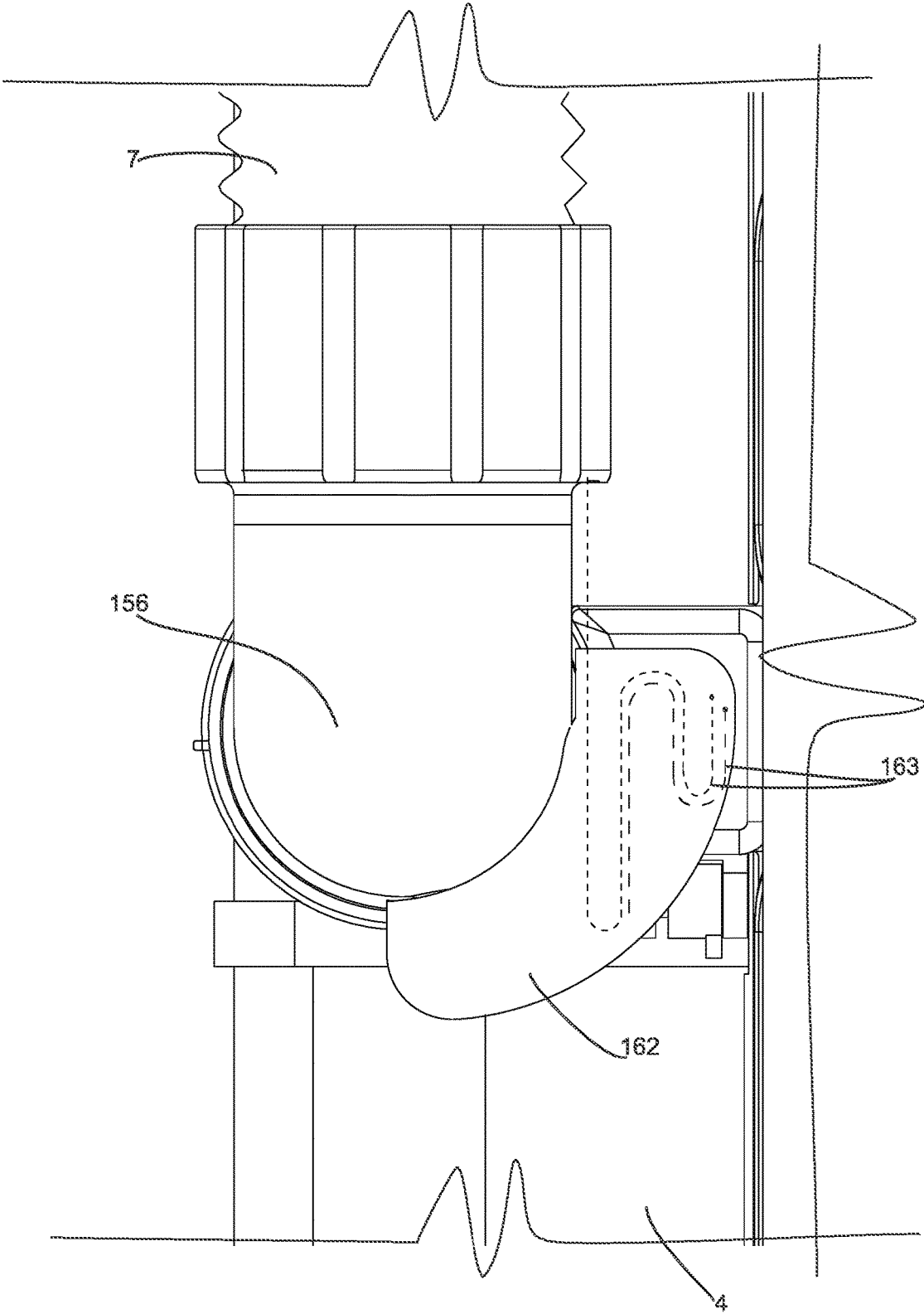

Fig. 69

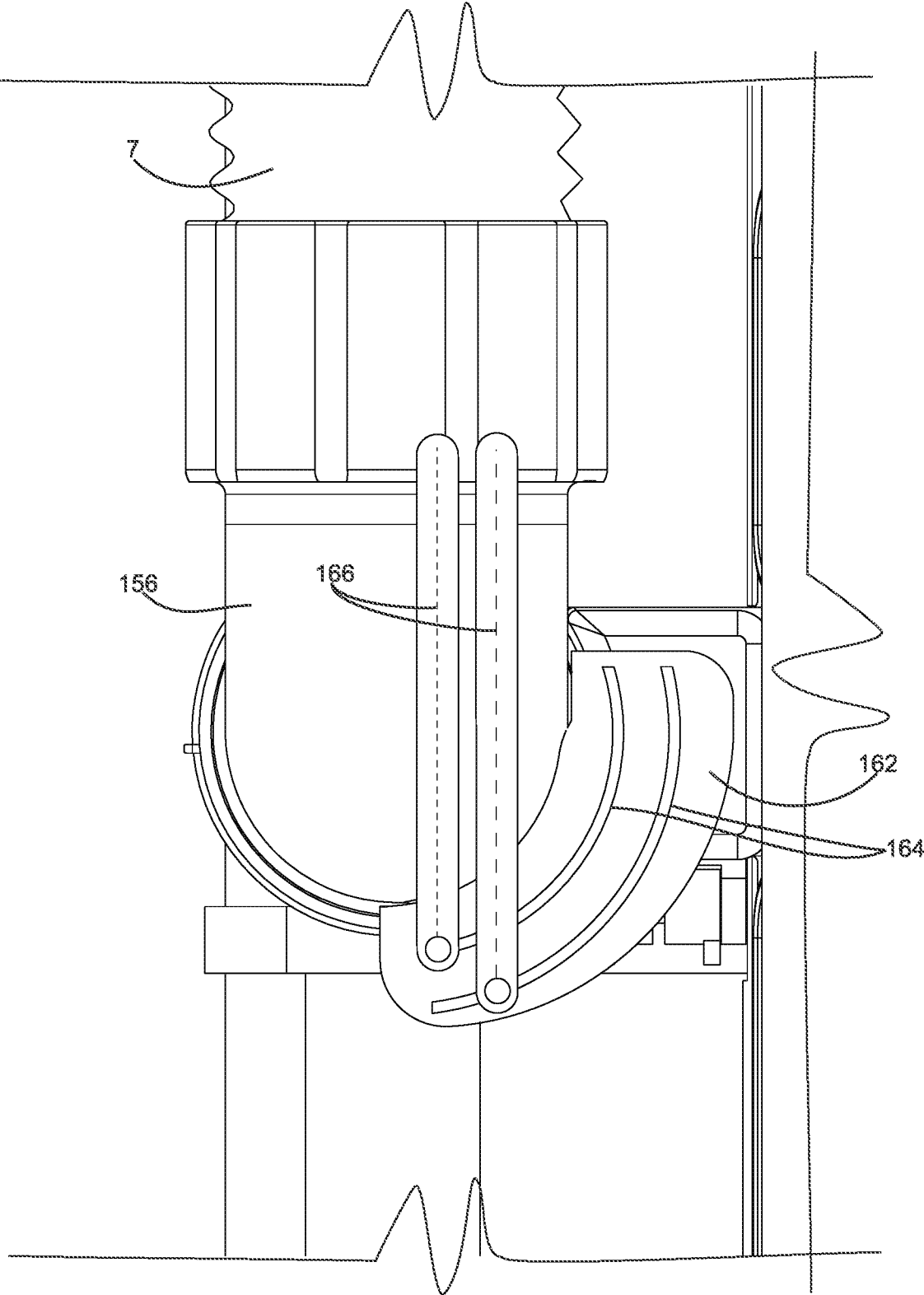

Fig. 70

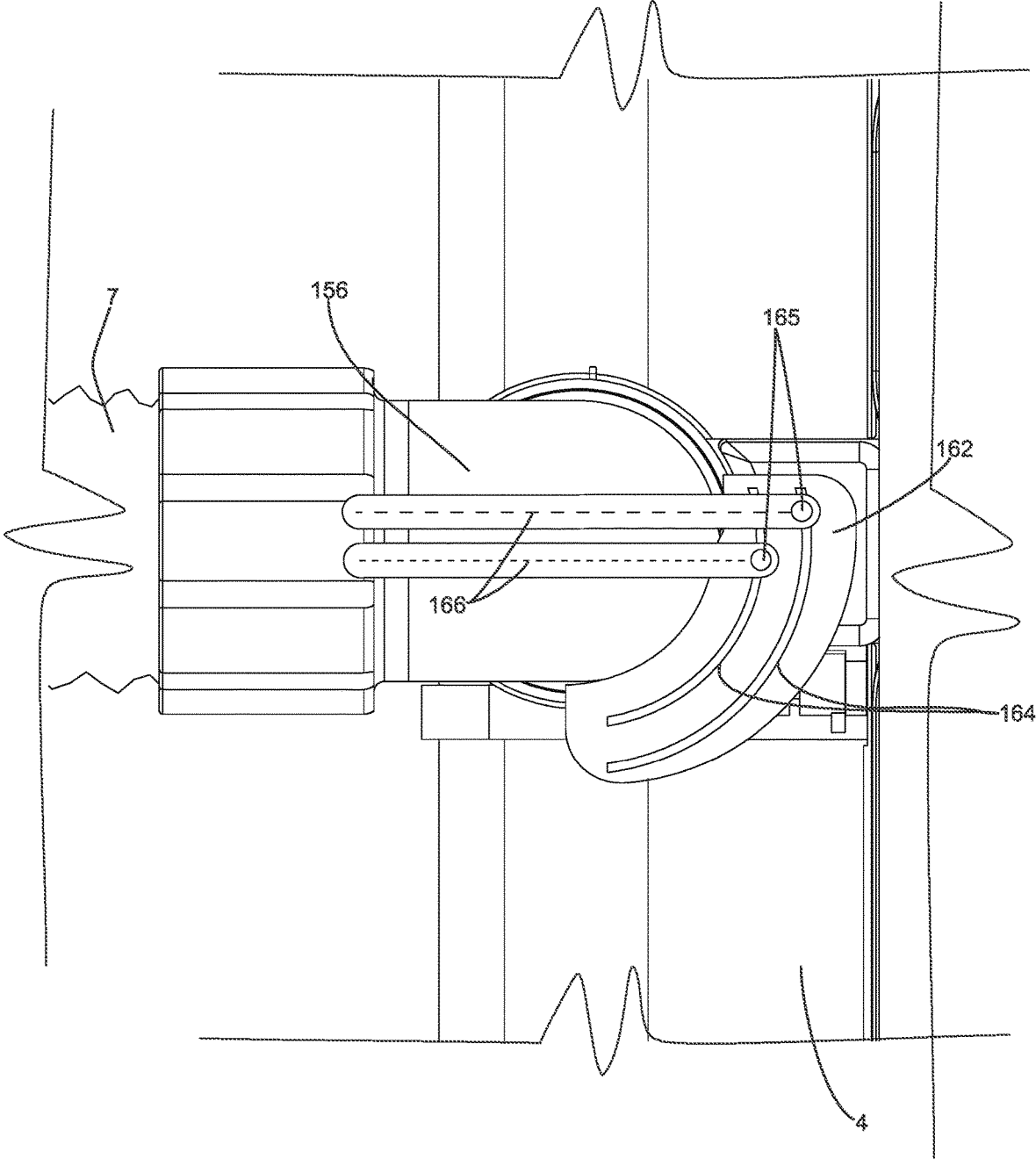

Fig. 71

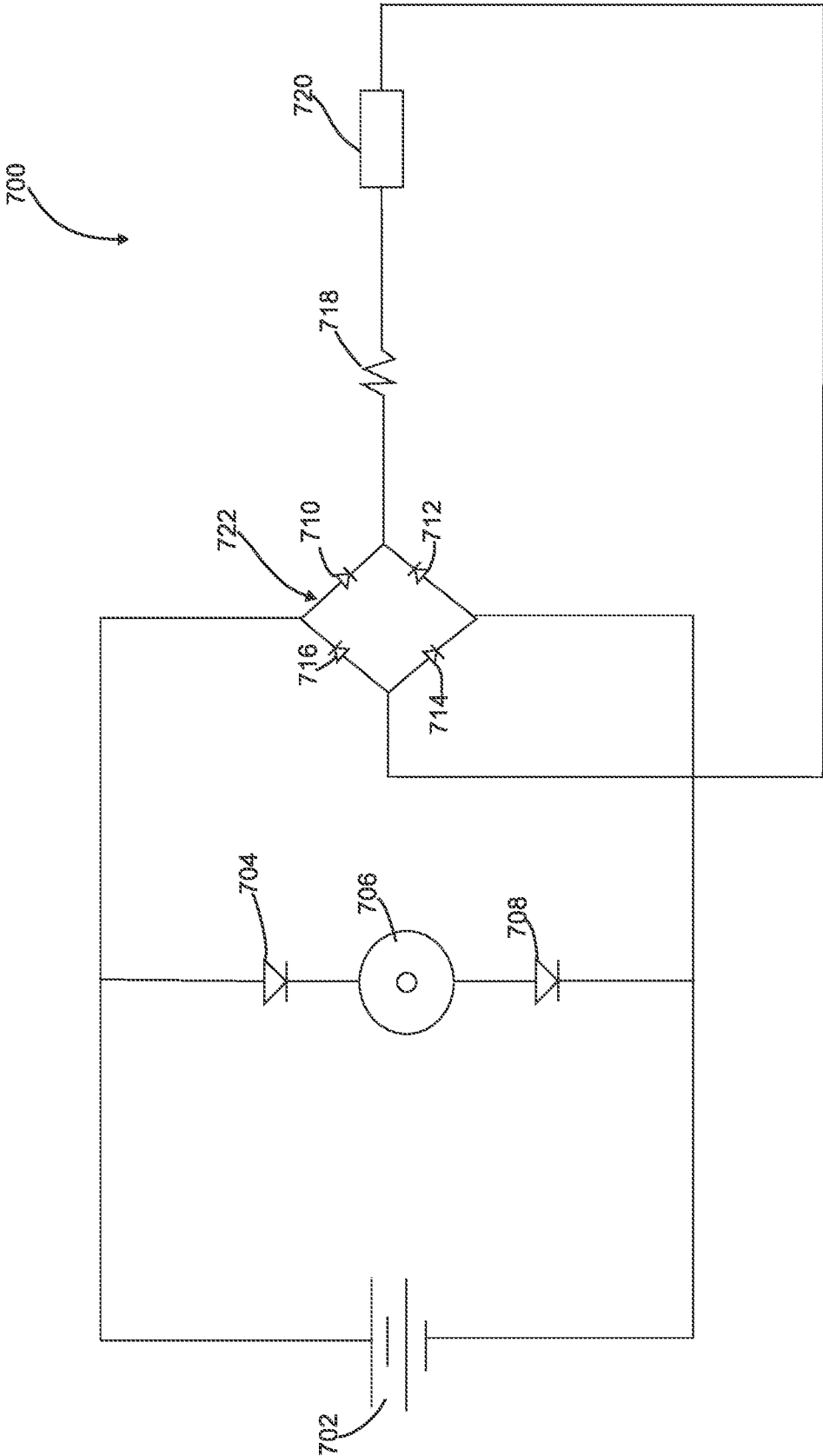

Fig. 72

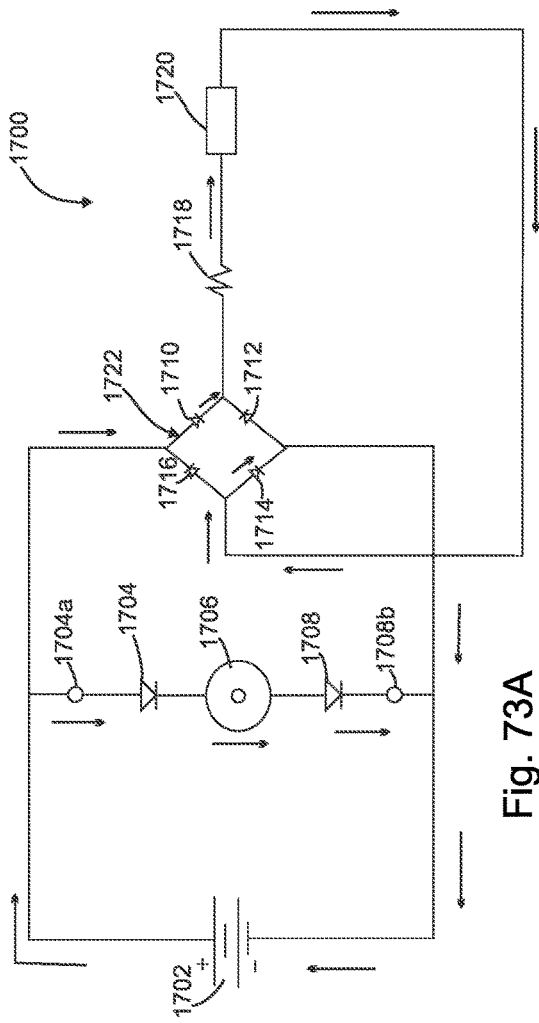

Fig. 73A

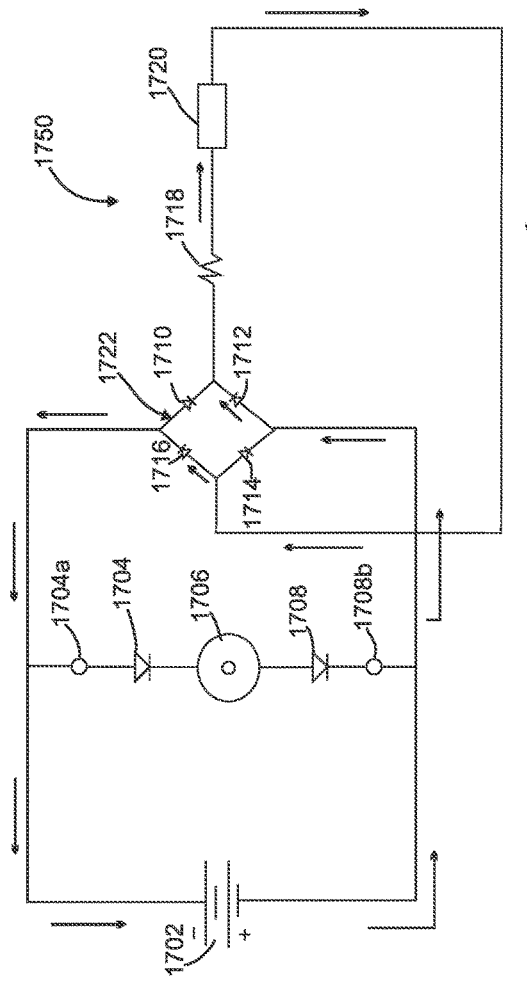

Fig. 73B

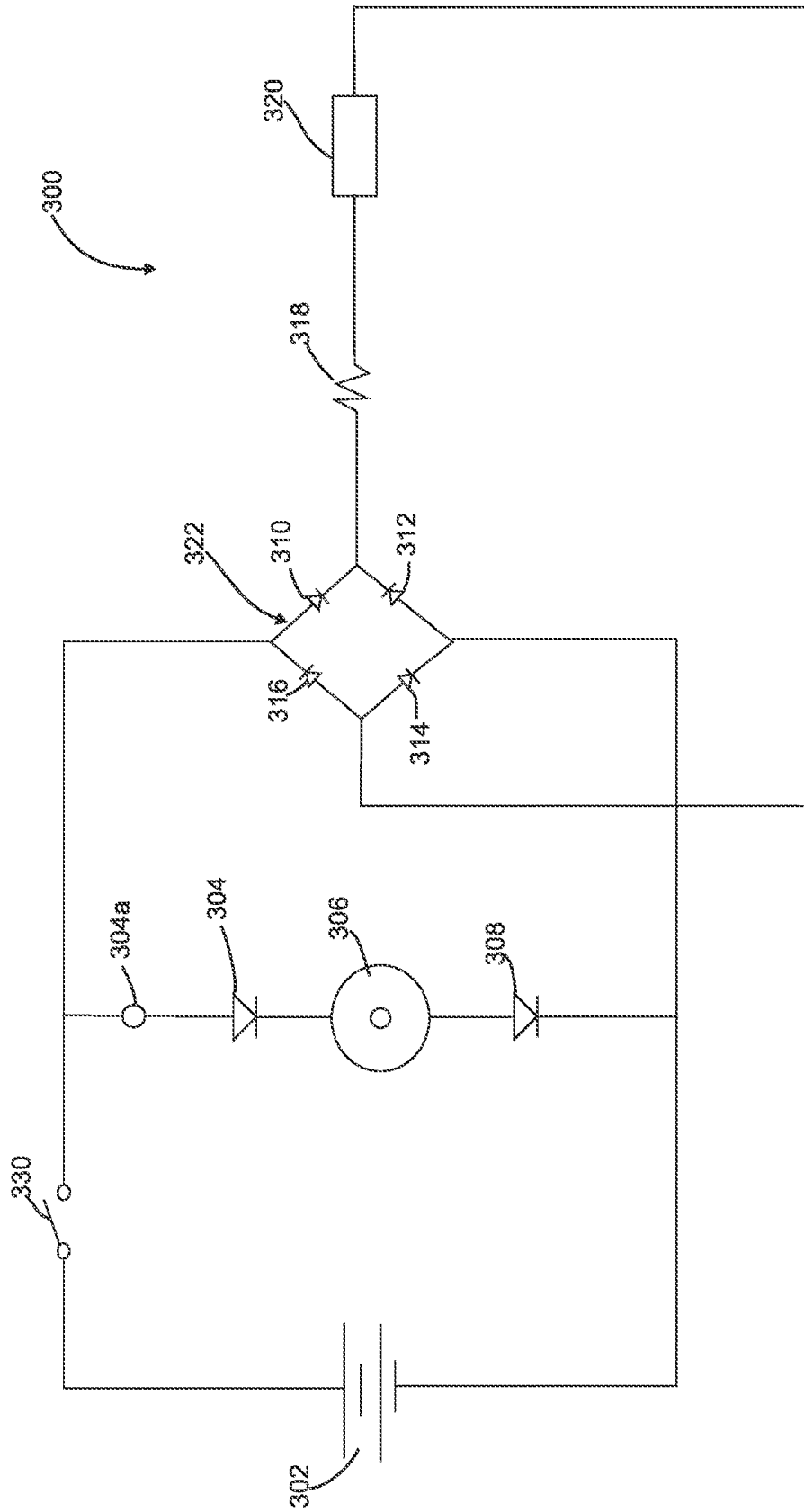

Fig. 74

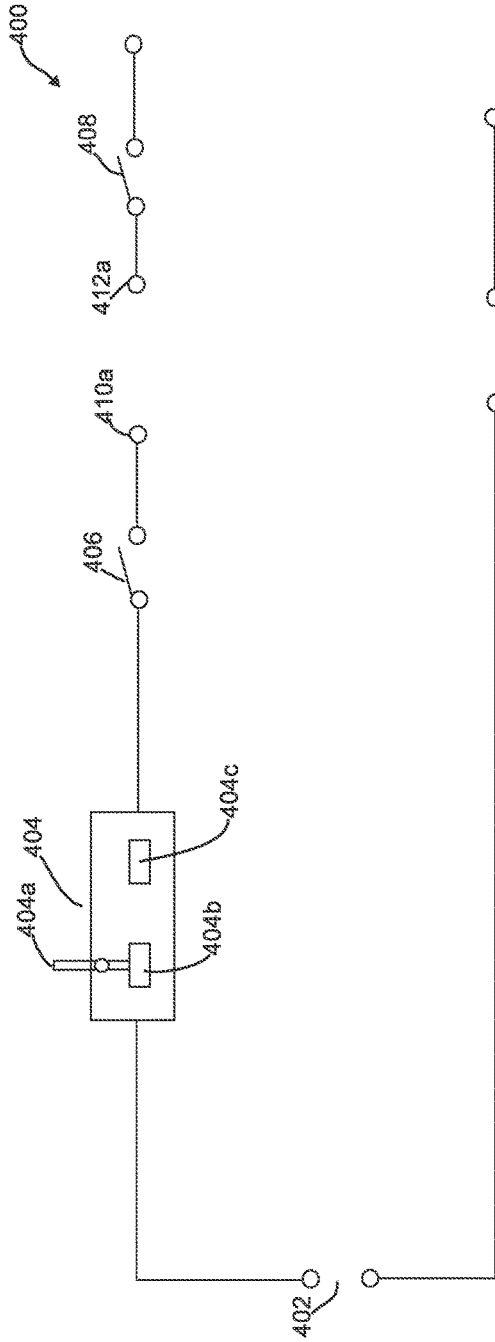

Fig. 75A

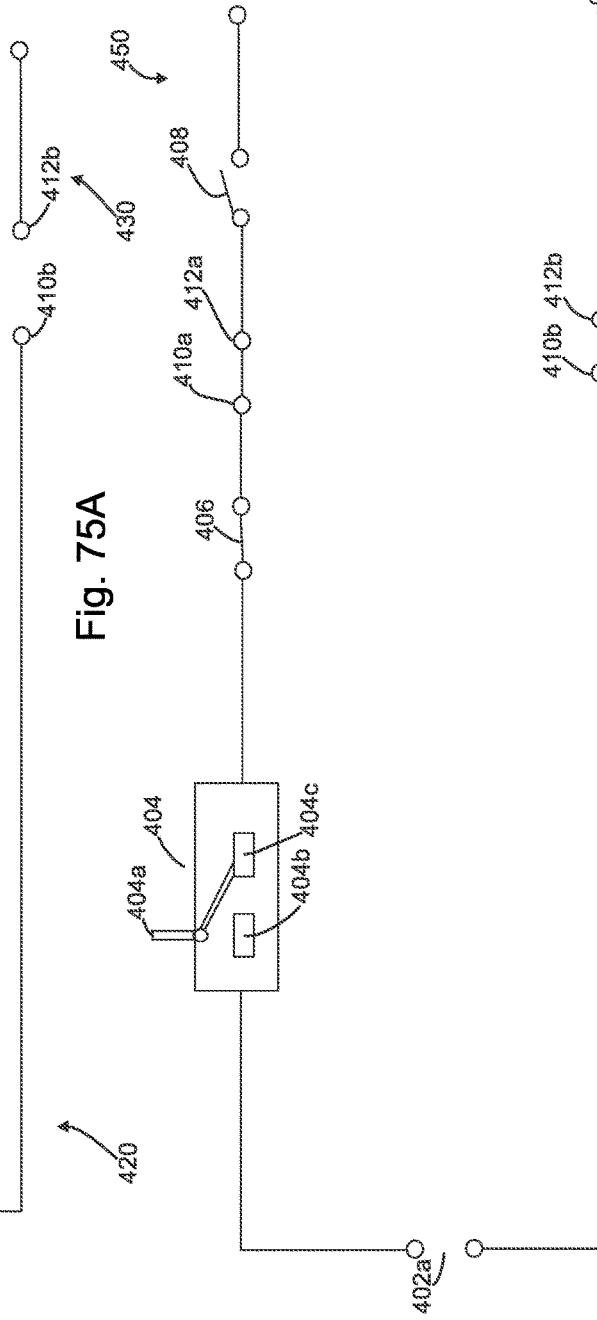

Fig. 75B

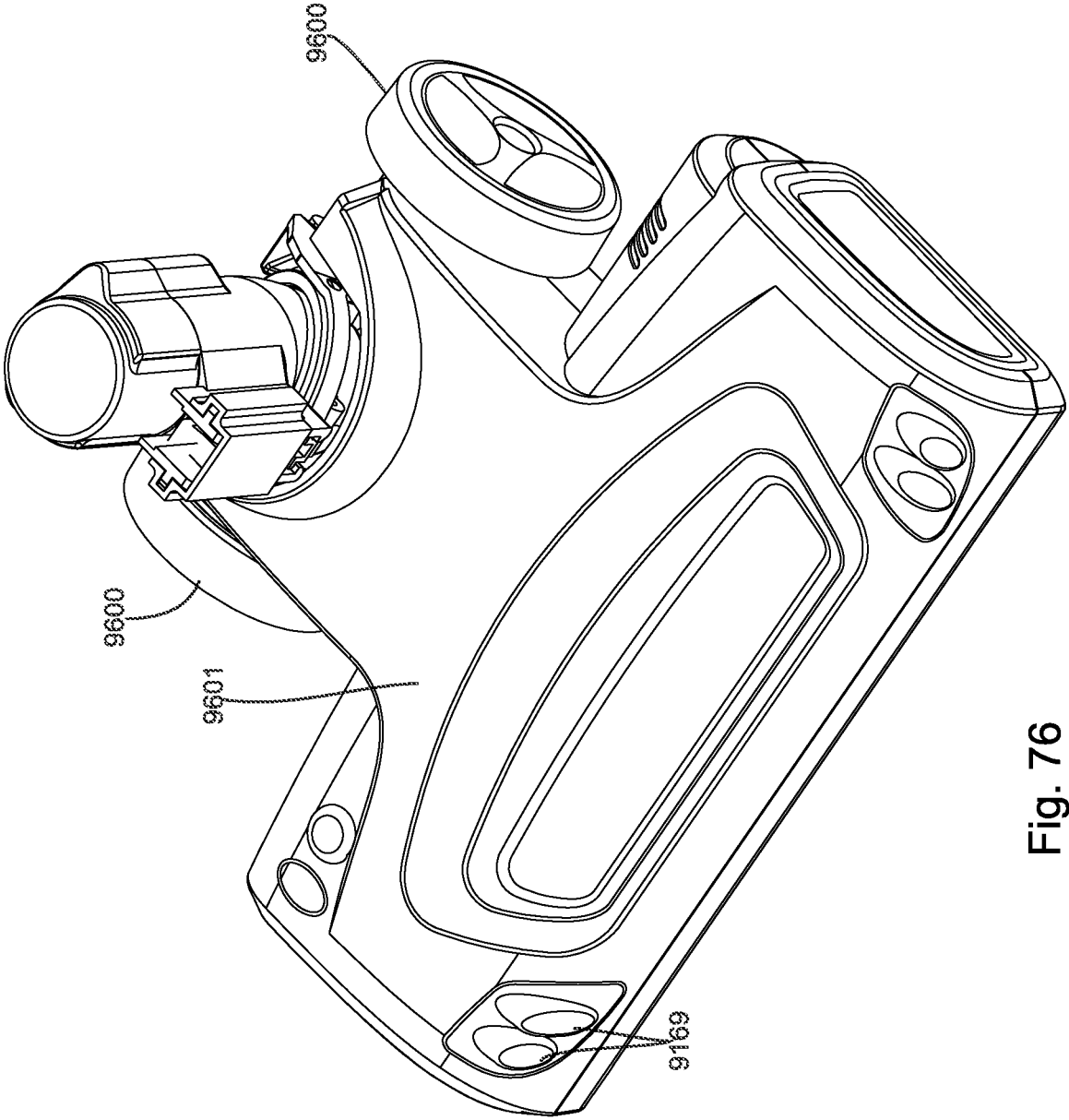

Fig. 76

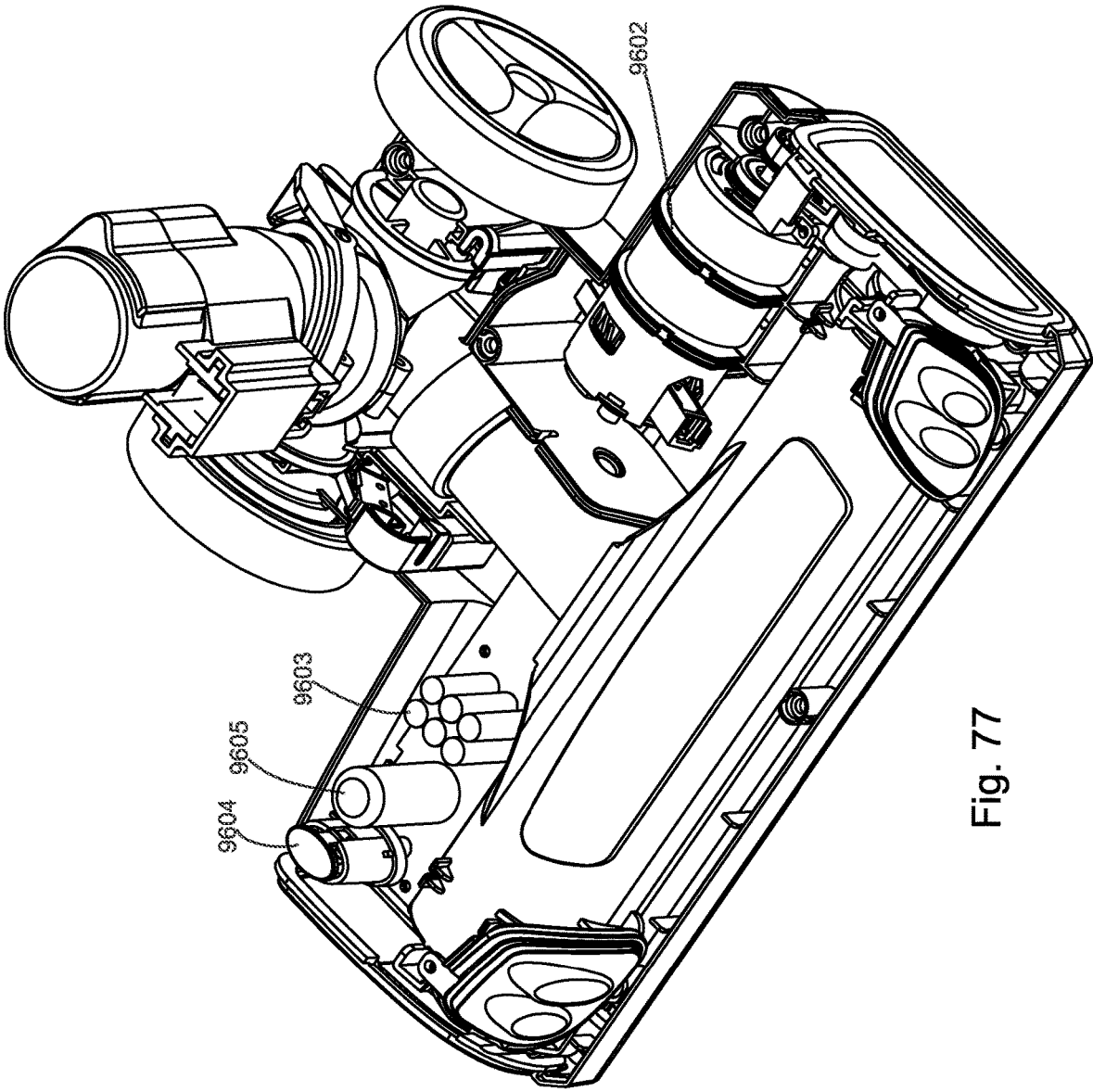

Fig. 77

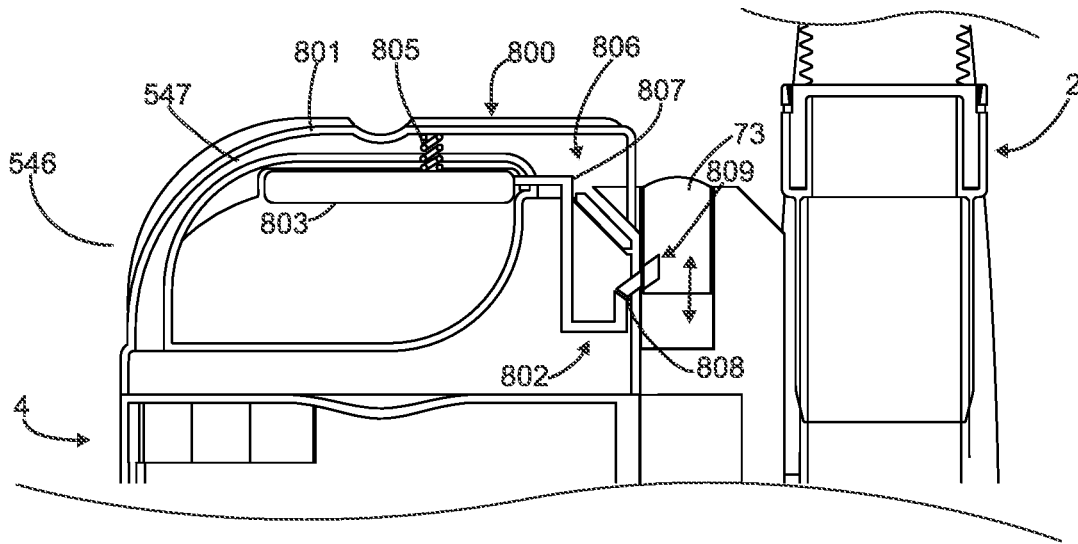

Fig. 78A

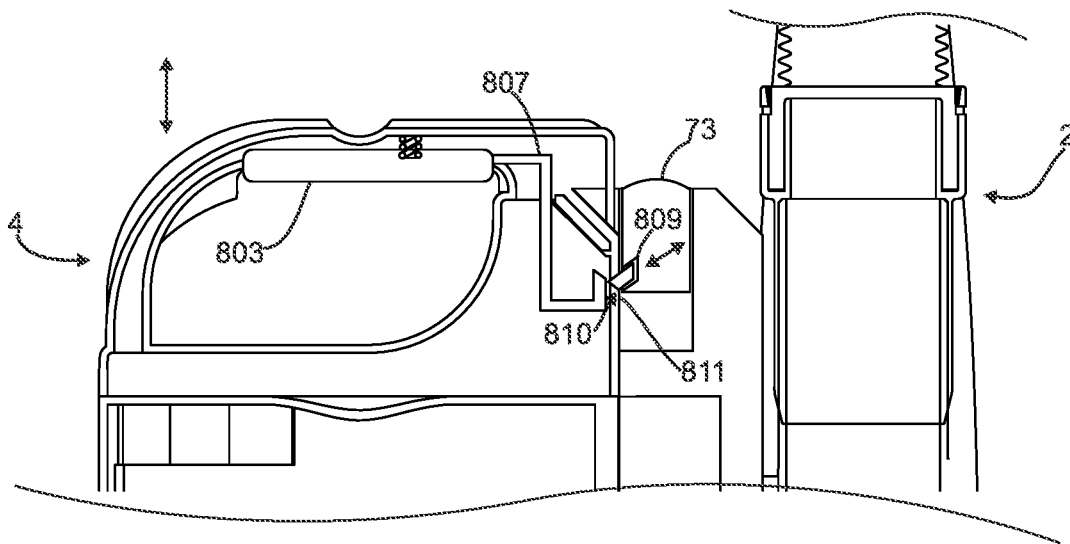

Fig. 78B

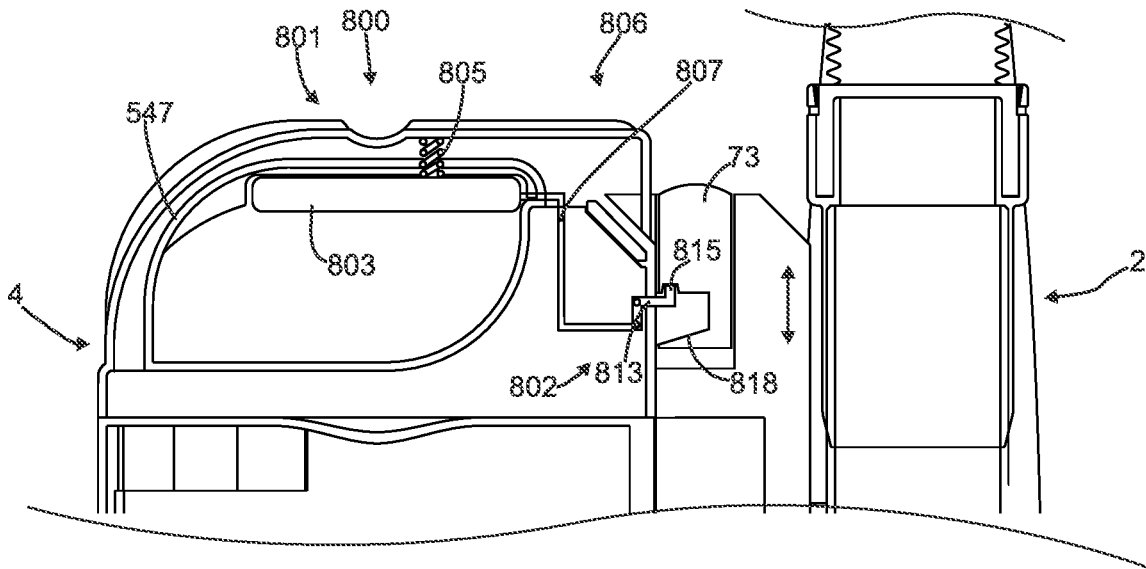

Fig. 79A

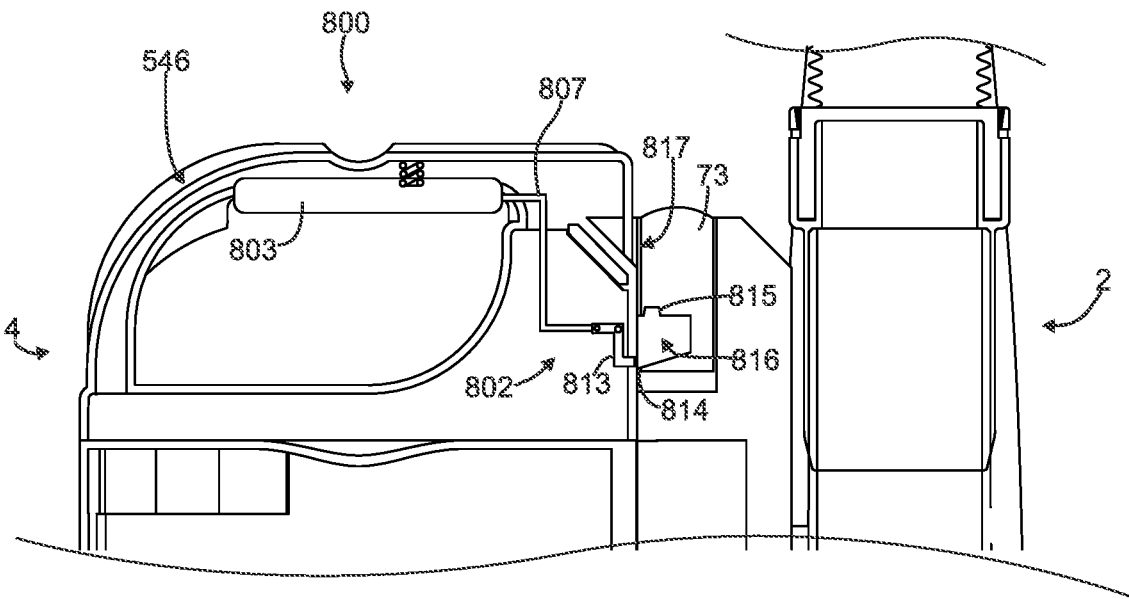

Fig. 79B

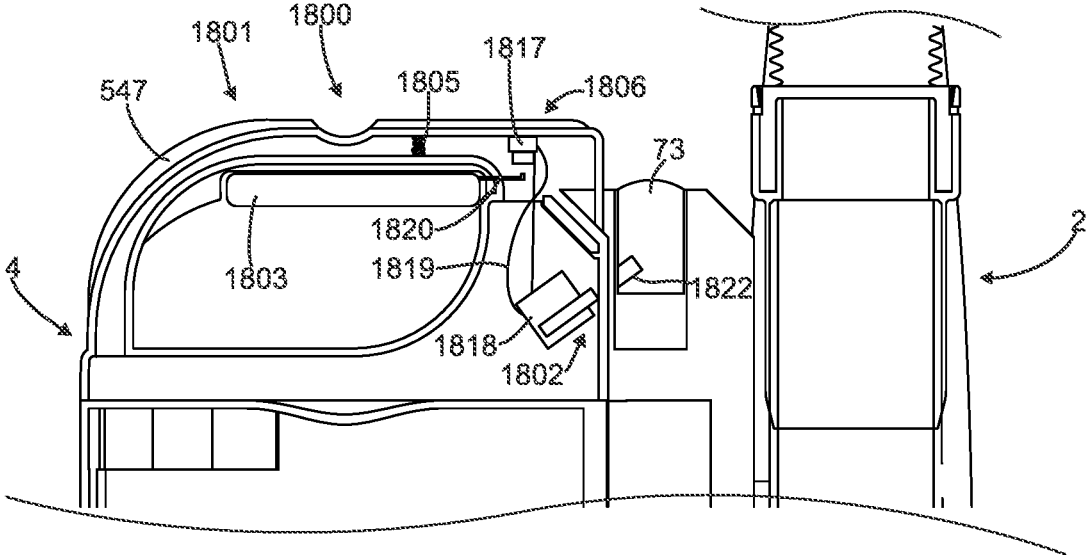

Fig. 80A

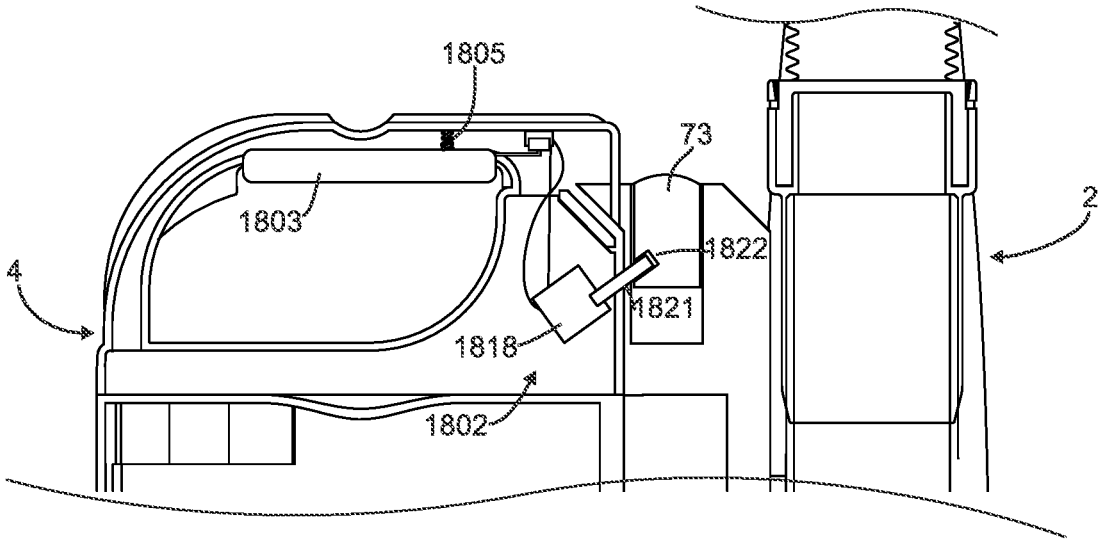

Fig. 80B

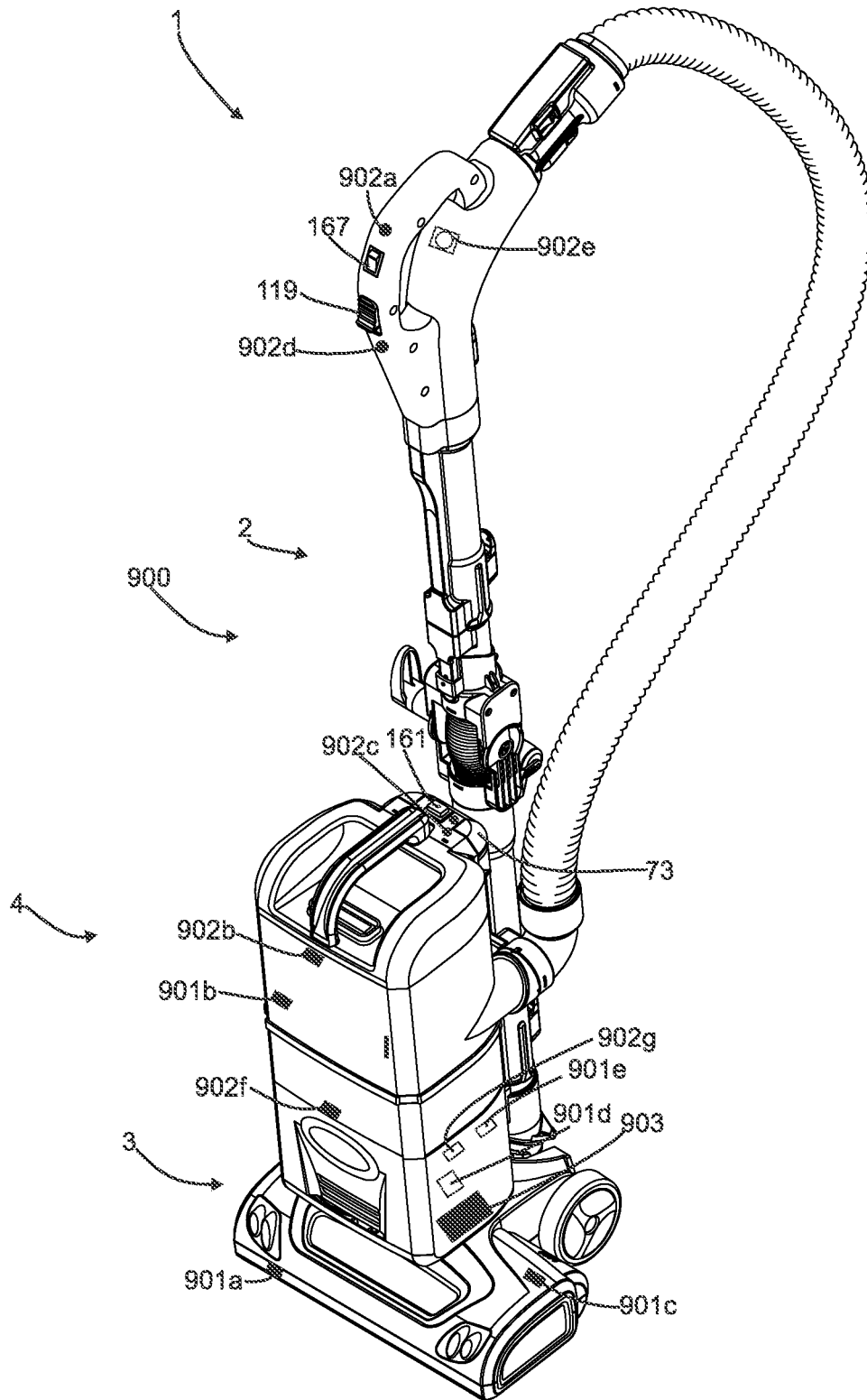

Fig. 81

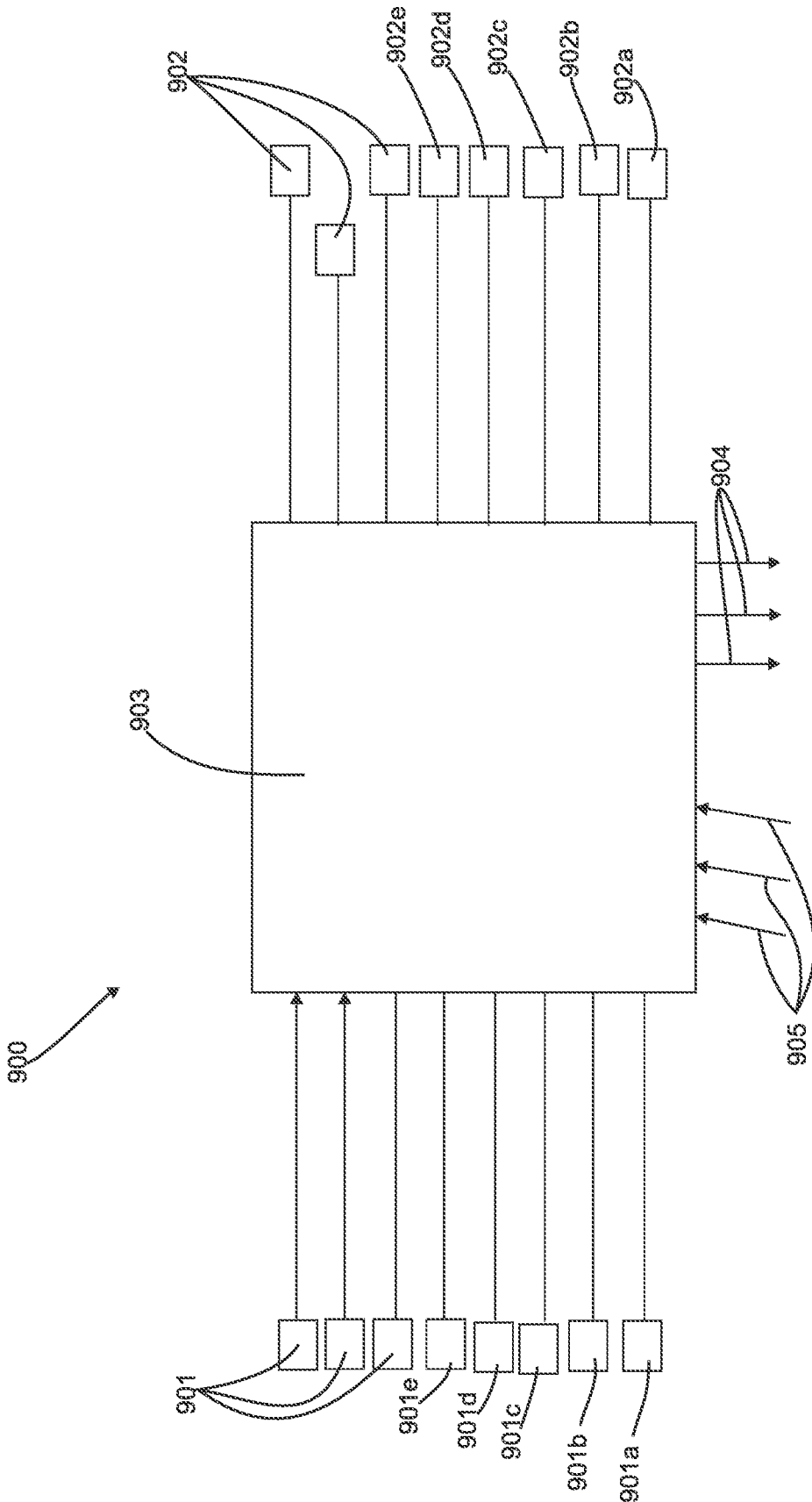

Fig. 82

SURFACE CLEANING APPARATUS**CROSS-REFERENCE TO PRIOR APPLICATIONS**

This application is a continuation of and claims the benefit of U.S. patent application Ser. No. 14/301,204 filed on Jun. 10, 2014, which is a continuation of and claims the benefit of U.S. patent application Ser. No. 13/781,324 filed on Feb. 28, 2013, now issued U.S. Pat. No. 9,456,721, each of which is incorporated herein in its entirety by reference.

FIELD

This specification relates to surface cleaning apparatus. In a preferred embodiment, the surface cleaning apparatus is an upright surface cleaning apparatus that has a portable surface cleaning unit, such as a hand vacuum cleaner or a pod, which is selectively detachable therefrom, such as an upper section of the upright surface cleaning apparatus.

INTRODUCTION

The following is not an admission that anything discussed below is part of the prior art or part of the common general knowledge of a person skilled in the art.

Various types of surface cleaning apparatus are known. Typically, an upright vacuum cleaner includes an upper section, including an air treatment member such as one or more cyclones and/or filters, drivingly mounted to a surface cleaning head. An up flow conduit is typically provided between the surface cleaning head and the upper section. In some such vacuum cleaners, a spine, casing or backbone extends between the surface cleaning head and the upper section for supporting the air treatment member. The suction motor may be provided in the upper section or in the surface cleaning head.

Surface cleaning apparatuses having a portable cleaning module that is removably mounted to an upright vacuum cleaner are known. See for example U.S. Pat. No. 5,309,600, 4,635,315 and US 2011/0314629. US 2011/0314629 discloses an upright vacuum cleaner having a surface cleaning head and an upright section pivotally mounted thereto. A hand vacuum cleaner is removably mounted on the upper section and is connected in airflow communication with the surface cleaning head via a flexible hose. A portion of the upper section is bendable so as to allow the surface cleaning head to extend under furniture. This bendable portion is external to the airflow path. In use, the hand vacuum cleaner is locked on the upper section. A user may manually unlock the hand vacuum cleaner so as to remove it for use as a hand vacuum cleaner and/or for emptying the cyclone bin assembly.

SUMMARY

This summary is intended to introduce the reader to the more detailed description that follows and not to limit or define any claimed or as yet unclaimed invention. One or more inventions may reside in any combination or sub-combination of the elements or process steps disclosed in any part of this document including its claims and figures.

According to one broad aspect, a surface cleaning apparatus, such as an upright vacuum cleaner, is provided which has a portable surface cleaning unit (such as a pod or hand vacuum cleaner) which is removably mounted thereto, such as to an upper portion that is pivotally mounted to a surface

cleaning head. The surface cleaning apparatus is configured such that the lock which secures the pod in position is automatically unlocked when the upper portion is moved to a floor cleaning position (e.g. the upper section is rotated rearwardly with respect to the surface cleaning head). The surface cleaning apparatus also includes a retaining member which maintains the pod on the upper portion when the lock is disengaged.

An advantage of this design is that the user may commence using the surface cleaning apparatus, such as by rotating a handle rearwardly and pushing the surface cleaning head over a surface to be cleaned. At some point during the operation, the user may desire to remove the pod from the upper portion. For example, the user may desire to clean under a piece of furniture and may therefore want to remove the pod so as to enhance the ability of the surface cleaning apparatus to extend further under the furniture. Alternately, the user may wish to use the pod as a portable surface cleaning unit without the remainder of the surface cleaning apparatus. In such a case, the user may pick up the pod and remove it from the upper portion while still holding the handle of the upper section in a floor cleaning position using their other hand. Accordingly, since the locking mechanism has been unlocked by the movement of the upper portion to the floor cleaning position, the user need not stop cleaning to disengage a lock and remove the pod. Instead, the user may remove the pod while still cleaning a carpet.

In accordance with this aspect, the retaining member that is utilized to mount the surface cleaning unit on the upper portion may be a magnet or a mechanical member which is configured to secure the portable surface cleaning unit in position due to the influence of gravity. For example, the retaining member may be a magnet on one or both of the pod and the upper portion. Alternately or in addition, the retaining member may comprise one or more fingers or engagement members which extend into the pod and/or the pod may have one or more fingers or other engagement members that extend into a mount provided on the upper portion. In a particularly preferred embodiment, the upper section is provided with a channel, such as a U-shaped channel, which has a seat at the bottom and the portable pod is provided with a mating structure, for example, a mounting member, which is configured to be received in the channel. The bottom of the mounting member may be provided with one or more protrusions which extend into an opening, recess or the like provided in the base of the U-shaped channel. The U-shaped channel may accordingly have sidewalls which extend forwardly and surround or abut the mounting member. An advantage to this particular design is that the sidewalls provide lateral stability to the portable surface cleaning unit (pod) when the lock is disengaged.

The lock may be of various constructions. For example, the lock could be electronic (e.g. it can be electronically actuated) or it could be a mechanically operable lock. With respect to the former, for example, the lock may comprise a solenoid or other motorized driver which is drivingly connected to an engagement member, such as a pin. When the upper portion is moved into the floor cleaning mode, a signal could be automatically sent to the solenoid, deactivating the lock (e.g., withdrawing a pin from engagement in a recess). It will be appreciated that the locking mechanism could be provided either on the portable surface cleaning unit, or on the upper portion, or both. The signal could be provided by a sensor provided on the upper portion. A mechanical locking mechanism can also be used. For example, a gravity based locking mechanism could be used. Accordingly, when

the upper section is moved rearwardly, a weight could move a lever or other mechanism causing a lock to disengage.

Alternately, the portable surface cleaning apparatus may be provided with a strap (e.g., a shoulder strap), which is preferably retractable. For example, the shoulder strap may be an elasticized member which is biased to a retracted position wherein the shoulder strap is stored in a shoulder strap holder, preferably provided on the rear of the surface cleaning apparatus. Alternately, the shoulder strap could be mounted on a reel, which, preferably, is also provided on the rear of the portable surface cleaning unit. In use, a user may remove the portable surface cleaning unit from the upper portion and carry the portable surface cleaning unit using the shoulder strap.

The air treatment member (e.g. a cyclone bin assembly) of the portable surface cleaning unit may be openable to allow the cyclone bin assembly to be emptied. Preferably, an openable lid is provided and a carry handle for the portable surface cleaning unit may be provided on the lid. The shoulder strap may be configured to abut the handle when in the retracted position. In order to assist the user to extend the shoulder strap to an in use position, one or more finger grooves may be provided on the handle so as to enable the user to reach underneath a portion of the strap and lift it off the handle. Alternately, or in addition, the forward portion of the shoulder strap may be secured to the lid. Accordingly, when the lid is opened to permit the user to empty the cyclone bin assembly, the shoulder strap will not interfere with this operation. For example, if the shoulder strap were secured to a forward portion of the cyclone bin assembly, then the strap would have to be moved out of the way to prevent it from blocking the lid from being opened.

It will be appreciated by a person skilled in the art that any of the features of the shoulder strap discussed herein need not be utilized with the automatic unlocking mechanism disclosed herein but may be used by itself or in combination with any other feature disclosed herein in a surface cleaning apparatus.

It will be appreciated that a user may desire to remove the portable surface cleaning unit (e.g., pod) when the surface cleaning apparatus has been stored (e.g. the upper portion is in the storage position and the lock is engaged). Accordingly, a release member, such as a button or other manually actuatable member may be provided to release the lock. Accordingly, the user may merely push a portable surface cleaning unit release button when the surface cleaning apparatus is in the upright position and remove the portable surface cleaning unit. Preferably, the release button is located proximate to a handle of the portable surface cleaning unit so as to enable a user to simultaneously push the button while holding the handle. A user could optionally utilize the handle of the portable surface cleaning unit to move the surface cleaning apparatus when the portable surface cleaning unit is mounted to the upper portion. In such a case, a lockout member may be provided to prevent the user from pushing the release button, or the release button operating, when the handle of the portable surface cleaning unit is used to carry or move the surface cleaning apparatus. An advantage of this design is that the user cannot accidentally release the portable surface cleaning unit (e.g., pod) and drop the surface cleaning apparatus when they are carrying the surface cleaning apparatus using the handle of the portable surface cleaning unit.

Different designs may be utilized for the lockout member. For example, a sensor may be provided on the handle which measures the force applied to the sensor. Accordingly, when a user uses the pod handle to carry the surface cleaning

apparatus, the sensor could detect a force equal to the weight of the surface cleaning apparatus. In such a case, the sensor could send a signal (e.g. to a solenoid) causing a lockout member (e.g. a pin), to prevent the button being depressed or to move a part of the release mechanism out of alignment with the button so that pressing the button will not release the lock. Alternately, if the lock is an electronic lock, then the sensor could disable a circuit so that pressing the button would not release the portable surface cleaning unit. Alternately, a mechanical lockout mechanism could be used. For example, the handle of the portable surface cleaning unit could be moveably mounted. Accordingly, when a user picks up the surface cleaning apparatus using the handle of the portable surface cleaning unit, the handle could be moved upwardly a sufficient distance so as to disengage the button from the lock mechanism or, alternately, to drive a linking member to block the downward movement of the button or to move a portion of the locking mechanism out of alignment with the button.

It will be appreciated by a person skilled in the art that any of the features of the lockout member discussed herein may not be utilized with the automatic unlocking mechanism disclosed herein but may be used by itself or in combination with any other feature disclosed herein in a surface cleaning apparatus.

It will be appreciated that the portable surface cleaning unit could be released by means of a foot peddle. An advantage of this design is that the user could hold the handle of the upper section in one hand, the handle of the portable surface cleaning unit in another hand, and simultaneously release the portable surface cleaning unit by depressing a foot peddle. It will be appreciated that the lockout member discussed previously could be utilized to disable a foot peddle release. The foot peddle could be mechanically linked to the locking mechanism or it could be electronically linked (e.g., as part of a wired or wireless circuit). It will be appreciated by a person skilled in the art that any of the features of the foot peddle discussed herein may not be utilized with the automatic unlocking mechanism disclosed herein but may be used by itself or in combination with any other feature disclosed herein in a surface cleaning apparatus.

Optionally, the surface cleaning apparatus may have an upper portion that is bendable (e.g. the upper portion may comprise first and second portions that are pivotally mounted to each other). The upper portion preferably comprises a portion of an airflow path of the surface cleaning apparatus. Accordingly, if the upper portion is part of the airflow path, and the user wants to, e.g. remove the portable surface cleaning unit to clean under furniture, the upper portion may be bent so as to enhance the extent to which the surface cleaning head may extend under furniture without compromising the airflow path. Further, the bendable upper portion may comprise an above-floor cleaning wand. Accordingly, the above-floor cleaning wand could be removed from a mount and an accessory tool attached thereto. The bendable wand would enable a user enhanced flexibility when cleaning using such an accessory tool. It will be appreciated by a person skilled in the art that any of the features of the bendable wand discussed herein may not be utilized with the automatic unlocking mechanism disclosed herein but may be used by itself or in combination with any other feature disclosed herein in a surface cleaning apparatus.

It will be appreciated that the auxiliary tool which is utilized may be battery operated, e.g., a battery operated mini surface cleaning head. Such a surface cleaning head

5

may have a rotary brush driven by a motor which is powered by batteries. Accordingly, when used in the above-floor cleaning mode, a motorized surface cleaning head may be used with the above-floor cleaning wand. It will be appreciated that other battery operated auxiliary tools could be utilized when a non-electrified hose is utilized. It will be appreciated that, if an electrified hose is utilized, that the battery in the auxiliary tool may be charged when connected to the above-floor cleaning wand. Alternately, if an electrified stretch hose is utilized, power for the motor in the auxiliary tool may be transmitted by the electrified hose. It will be appreciated by a person skilled in the art that any of the features of the battery operated tool and/or electrified stretch hose discussed herein may not be utilized with the automatic unlocking mechanism disclosed herein but may be used by themselves or in combination with any other feature disclosed herein in a surface cleaning apparatus.

Optionally, if the portable surface cleaning unit includes a cyclone bin assembly, then the cyclone bin assembly may be removably mounted to the portable surface cleaning unit. An advantage of this design is that the user need not carry the entire portable surface cleaning unit to a garbage bin or the like to empty the cyclone bin assembly. In addition, the cyclone bin may be removable from the portable surface cleaning unit while the portable surface cleaning unit is mounted to the upper portion. In accordance with this embodiment, it is preferred that the locking mechanism that secures the cyclone bin assembly on the portable surface cleaning unit is located internally. For example, a cyclone bin assembly lock which secures a cyclone bin assembly of the portable surface cleaning unit may have a first locking member provided on the cyclone bin assembly and the second locking member provided on another portion of the portable surface cleaning unit (such as a suction motor housing). Both of these locking members are preferably provided interior of the portable surface cleaning unit. A user may press a button on the exterior of the portable surface cleaning unit (e.g. proximate a pod handle). The button may actuate the lock and move it to the disengaged position. It will be appreciated that the lock may be an electronic lock or a mechanical lock. If the lock is electrically operated, then the button may send a signal to a motor, causing the lock to disengage. The signal may be sent via wires or wirelessly. It will be appreciated that the moveable portion of the locking mechanism may be located in the cyclone bin assembly and/or, e.g., the motor housing of the portable surface cleaning unit. If the lock is a mechanical lock, then part of the mechanism (e.g., the driving linking member) may extend through the cyclone bin assembly (e.g. via the vortex finder) to the second locking member. Accordingly, it will be appreciated that a portion of the airflow path (e.g. the vortex finder) may be utilized as part of the conduit through which the locking member extends. It will be appreciated by a person skilled in the art that any of the features of the internal locking mechanism discussed herein may not be utilized with the automatic unlocking mechanism disclosed herein but may be used by itself or in combination with any other feature disclosed herein in a surface cleaning apparatus.

Optionally, the surface cleaning apparatus may include one or more lights (preferably LEDs) which indicate the status of the surface cleaning apparatus. For example, the dirt collection bin may include a sensor to detect when the dirt collection bin is full. The sensor may send a signal causing an LED to illuminate when the sensor detects that the bin is full. The sensor could cause the LED to remain illuminated or to flash. For example, the LED may flash,

6

when the bin is approaching full, and may be fully illuminated when the bin is full. Similarly, a sensor may be provided for detecting when a filter (e.g. a pre-motor filter and/or a post-motor filter), requires cleaning or replacement.

The sensor may communicate with the same and, preferably, an alternate LED. The surface cleaning apparatus may include a rotary brush which automatically adjusts the rate of rotation based on the surface being cleaned. For example, the brush may be automatically disengaged when cleaning a bare floor and may have a higher rate of rotation when cleaning a short pile carpet and may have a slower rate of rotation when cleaning a higher pile carpet. The surface cleaning apparatus may include a plurality of LEDs which illuminate depending on whether the brush is disengaged or depending upon the rate of rotation of the brush (e.g. a high speed, a low speed LED and a brush off LED). It will be appreciated by a person skilled in the art that any of the features of the lights discussed herein may not be utilized with the automatic unlocking mechanism disclosed herein but may be used by itself or in combination with any other feature disclosed herein, in a surface cleaning apparatus.

In one embodiment there is provided a surface cleaning apparatus having comprising:

25 a surface cleaning head having a dirty air inlet;
 an upper portion moveably mounted to the surface cleaning head between a storage position and a floor cleaning position, the upper portion comprising a wand;
 30 a portable surface cleaning unit removably mounted to the upper portion, the portable cleaning unit comprising a suction motor, an air treatment member and a carry handle;
 an air flow path extending from the dirty air inlet to a clean air outlet and comprising an upstream portion that extends from the dirty air inlet to the surface cleaning unit, upstream portion of the air flow path comprising the wand and a flexible air flow conduit downstream of the wand; and,
 35 the portable cleaning unit is removable from the upper portion while maintaining the portable cleaning unit in air flow communication with the surface cleaning head.

In some embodiments, the wand is removable from the surface cleaning head for use in an above floor cleaning mode.

In some embodiments, the surface cleaning head has a forward direction of motion and the portable cleaning unit is removably mounted to a front side of the upper portion.

In some embodiments, the apparatus includes a portable surface cleaning unit lock having a locked position in which the portable surface cleaning unit is secured to the upper portion and an unlocked position in which the portable surface cleaning unit is removable from the upper portion and the portable surface cleaning unit lock is actuatable by a user while the user is operating the surface cleaning apparatus with one of the user's hands.

In some embodiments, the lock is button actuated.

In some embodiments, the air treatment member comprises a cyclone bin assembly and the cyclone bin assembly is removable while the portable cleaning unit is mounted to the upper section.

In some embodiments, the portable surface cleaning unit comprises the clean air outlet.

In some embodiments, the wand comprises a handle section and the handle section is removably mounted to an upper end of the wand.

In some embodiments, the apparatus also includes:

65 a portable surface cleaning unit lock having a locked position in which the portable surface cleaning unit is

secured to the upper portion and an unlocked position in which the portable surface cleaning unit is removable from the upper portion; and,

a retaining member maintaining the portable surface cleaning unit on the upper portion when the portable surface cleaning unit lock is in the unlocked position and the upper portion is in the floor cleaning position.

In some embodiments, the retaining member comprises a member configured to retain the portable surface cleaning unit on the upper portion under the influence of gravity.

In some embodiments, the portable surface cleaning unit has an openable lid provided on a cyclone bin assembly body and handle is provided on the openable lid.

In some embodiments, the upper portion further comprises first and second portions that are part of the air flow path, and the second portion is rotatable relative to the first portion about an axis that intersects a longitudinal axis of at least one of the first and second portions.

In some embodiments, a downstream end of the flexible air flow conduit is mounted to a sidewall of the portable cleaning unit.

In some embodiments, a downstream end of the flexible air flow conduit is rotatably mounted to the portable cleaning unit.

In some embodiments, the air treatment member comprises a cyclone, the portable cleaning unit comprises a suction motor housing and the cyclone is positioned above the suction motor.

In some embodiments, the air treatment member comprises a cyclone bin assembly that is mounted to the suction motor housing.

In some embodiments, the downstream end of the flexible air flow conduit is mounted to a sidewall of the cyclone bin assembly.

In some embodiments, the flexible air flow conduit comprises an electrified stretch hose.

In another embodiment, there is provided a surface cleaning apparatus having comprising:

a surface cleaning head having a dirty air inlet and an upper section mount moveably mounted thereto;

an upper portion moveably mounted to the upper section mount and moveable between a storage position and a floor cleaning position, the upper portion comprising a wand;

a portable surface cleaning unit removably mounted to the upper portion, the portable cleaning unit comprising a suction motor, an air treatment member and a carry handle;

an air flow path extending from the dirty air inlet to a clean air outlet and comprising an upstream portion that extends from the dirty air inlet to the surface cleaning unit, upstream portion of the air flow path comprising the wand and a flexible air flow conduit downstream of the wand; and,

each of the wand and the portable cleaning unit is separately removable from the upper section mount.

In some embodiments, the wand is removable while the portable cleaning unit remains in position on the upper section mount and while the wand remains in air flow communication with the portable cleaning unit.

In some embodiments, the portable cleaning unit is removable from the upper section mount while maintaining the portable cleaning unit in air flow communication with the surface cleaning head.

In some embodiments, the apparatus also includes a single locking member securing the wand and the portable cleaning unit on the upper section mount.

In some embodiments, the single locking member includes a single actuator.

In one embodiment, there is provided a surface cleaning apparatus comprising:

(a) a surface cleaning head having a dirty air inlet;

(b) an upper portion moveably mounted to the surface cleaning head between a storage position and a floor cleaning position;

(c) a portable surface cleaning unit comprising a suction motor and an air treatment member removably mounted to the upper portion;

(d) an air flow path extending from the dirty air inlet and including a flexible air flow conduit forming at least part of an air flow path from the dirty air inlet to the surface cleaning unit;

(e) a portable surface cleaning unit lock having a locked position in which the portable surface cleaning unit is secured to the upper portion and an unlocked position in which the portable surface cleaning unit is removable from the upper portion; and,

(f) a retaining member maintaining the portable surface cleaning unit on the upper portion when the portable surface cleaning unit lock is in the unlocked position wherein the portable surface cleaning unit lock is automatically moved to the unlock position when the upper portion is moved to the floor cleaning position.

In some embodiments, the retaining member may comprise a magnet.

In some embodiments, the retaining member may comprise a member configured to retain the portable surface cleaning unit on the upper portion under the influence of gravity.

In some embodiments, the portable surface cleaning unit lock may be electrically operated.

In some embodiments, the portable surface cleaning unit lock may comprise a solenoid drivingly connected to a pin provided on one of the and the portable surface cleaning unit and the upper portion and a member engageable by the pin provided on the other of the portable surface cleaning unit and the upper portion.

In some embodiments, the surface cleaning apparatus may further comprise a sensor (the micro switch) operatively connected to the solenoid wherein the solenoid is actuated when the sensor detects motion of the upper portion between the storage and floor cleaning positions.

In some embodiments, the portable surface cleaning unit may further comprise a retractable shoulder strap.

In some embodiments, the portable surface cleaning unit may have an openable lid provided on a cyclone bin assembly body and the shoulder strap may have a first end secured to the cyclone bin assembly body and a second end secured to the openable lid.

In some embodiments, the portable surface cleaning unit may further comprise a handle, the shoulder strap may seat on the handle when in a retracted position and the handle may include at least one finger grip recess provided on a portion of the handle on which the shoulder strap seats when in a retracted position.

In some embodiments, the portable surface cleaning unit may further comprise a handle and the portable surface cleaning unit lock may comprise a locking member, a manually actuatable member (the pod lock button) may be operatively connected to the locking member and a lockout member may be provided for disabling the portable surface cleaning unit lock when the handle is used to carry the surface cleaning apparatus.

In some embodiments, the portable surface cleaning unit lock may be electrically operated and the lockout member may comprise a sensor that disables the portable surface

cleaning unit lock when the sensor determines that the handle is used the handle is used to carry the surface cleaning apparatus.

In some embodiments, the handle may be moveably mounted with respect to the portable surface cleaning unit and may be drivingly connected to the lockout member whereby, when the handle is used to carry the surface cleaning apparatus, the handle moves upwardly and drives the lockout member to a lockout position whereby the portable surface cleaning unit lock is disabled.

In some embodiments, the portable surface cleaning unit may further comprise a cyclone bin assembly removably mounted to a suction motor housing and a cyclone bin assembly lock may be provided that releasably secures the cyclone bin assembly to the suction motor housing, the cyclone bin assembly lock may comprise a first locking member provided on the cyclone bin assembly and a second locking member provided on the suction motor housing and the first and second locking members are provided internal of the portable surface cleaning unit.

In some embodiments, the cyclone bin assembly lock may further comprise a bin release actuator provided on an exterior of the surface cleaning unit.

In some embodiments, the cyclone bin assembly may have a lower surface that is configured to stand on a horizontal surface when removed from the suction motor housing.

In some embodiments, the portable surface cleaning unit may further comprise a handle and the cyclone bin assembly lock may further comprise a locking member, a manually actuatable member (the bin lock button) drivingly connected to the locking member and a lockout member disabling the cyclone bin assembly lock when a the handle is used to carry the surface cleaning apparatus.

In some embodiments, the upper portion may further comprise first and second portions that are part of the air flow path, and the second portion is rotatable relative to the first portion about an axis that intersects a longitudinal axis of at least one of the first and second portions.

In some embodiments, the upper portion may comprise a wand that is upstream of the flexible air flow conduit and the wand is removable for use in an above floor cleaning mode.

In some embodiments, the surface cleaning head may comprise a rotary brush driven by a brush motor and a battery that is operatively connected to the brush motor.

In some embodiments, the upper portion may comprise a wand that is upstream of the flexible air flow conduit and the wand and the portable surface cleaning unit are removable from the surface cleaning apparatus for use in an above floor cleaning mode and, when the wand and the portable surface cleaning unit are connected as part of the surface cleaning apparatus, the battery is electrically connected to the surface cleaning unit.

In one embodiment, there is provided a surface cleaning apparatus comprising:

- (a) a surface cleaning head having a dirty air inlet;
- (b) an upper portion moveably mounted to the surface cleaning head between a storage position and a floor cleaning position;
- (c) a surface cleaning unit comprising a handle, a suction motor and an air treatment member removably mounted to a support structure;
- (d) an air flow path extending from the dirty air inlet and including a flexible air flow conduit forming at least part of an air flow path from the dirty air inlet to the surface cleaning unit; and,

(e) at least one of the following:

(i) a surface cleaning unit lock having a locked position in which the surface cleaning unit is secured to the upper portion and an unlocked position in which the surface cleaning unit is removable from the upper portion; and,

(ii) if the surface cleaning unit further comprises a cyclone bin assembly removably mounted to a suction motor housing, a cyclone bin assembly lock that releasably secures the cyclone bin assembly to the suction motor housing,

(f) and the at least one of the surface cleaning unit lock and the cyclone bin assembly lock comprises a locking member, a manually actuatable member operatively connected to the locking member and a lockout member disabling the at least one of the surface cleaning unit lock and the cyclone bin assembly lock when the handle is used to carry the surface cleaning apparatus.

In some embodiments, the surface cleaning apparatus may comprise the surface cleaning unit lock.

In some embodiments, the surface cleaning apparatus may further comprise a retaining member maintaining the surface cleaning unit on the upper portion when the surface cleaning unit lock is in the unlocked position, wherein the surface cleaning unit lock is automatically moved to the unlocked position when the upper portion is moved to the floor cleaning position.

In some embodiments, the surface cleaning apparatus may comprise the cyclone bin assembly lock.

In some embodiments, the manually actuatable member may be positioned proximate or on the handle.

In some embodiments, the at least one of the surface cleaning unit lock and the cyclone bin assembly lock may be electrically operated and the lockout member is electronically operated.

In some embodiments, the lockout member may comprise a sensor that disables the lock when the sensor determines that the handle is used to carry the surface cleaning apparatus.]

In some embodiments, the sensor may comprise a pressure sensor provided on the handle.

In some embodiments, the lockout member may be mechanically operated.

In some embodiments, the handle may be moveably mounted with respect to the surface cleaning unit and may be drivingly connected to the lockout member whereby, when the handle is used to carry the surface cleaning apparatus, the handle moves upwardly and drives the lockout member to a lockout position whereby the lock is disabled.

In some embodiments, the handle may be drivingly connected to a cam member and the cam member may be drivingly connected to the lockout member.

In some embodiments, one of the handle and the lockout member may be part of the cam member.

In some embodiments, the surface cleaning apparatus may comprise both the surface cleaning unit lock and the cyclone bin assembly lock.

In some embodiments, the manually actuatable member may comprise a surface cleaning unit manually actuatable member and a cyclone bin assembly manually actuatable member and the lockout member may be configured to disable both the surface cleaning unit lock and the cyclone bin assembly lock.

In some embodiments, the at least one of the surface cleaning unit lock and the cyclone bin assembly lock may be electrically operated.

11

In some embodiments, the surface cleaning unit lock may comprise a solenoid drivingly connected to a pin provided on one of the surface cleaning unit and the upper portion and a member engageable by the pin provided on the other of the surface cleaning unit and the upper portion.

In some embodiments, the solenoid may be biased to the locked position when the solenoid is isolated from a source of power.

In some embodiments, the surface cleaning apparatus may further comprise a sensor operatively connected to the solenoid wherein the solenoid is actuated when the sensor detects motion of the upper portion between the storage and floor cleaning positions.

In some embodiments, the cyclone bin assembly lock may comprise a solenoid drivingly connected to a pin provided on one of the cyclone bin assembly and the suction motor housing and a member engageable by the pin provided on the other of cyclone bin assembly and the suction motor housing.

In some embodiments, the solenoid may be biased to the locked position when the solenoid is isolated from a source of power.

In one embodiment, there is provided a surface cleaning apparatus comprising:

- (a) a body housing a suction motor;
- (b) a cyclone bin assembly comprising at least one cyclone removably mounted to the body;
- (c) an air flow path extending from a dirty air inlet to a clean air outlet and including the suction motor and a cyclone bin assembly; and,
- (d) a cyclone bin assembly lock that releasably secures the cyclone bin assembly to the body, the cyclone bin assembly lock comprises a first locking member provided on the cyclone bin assembly and a second locking member provided on the body and the first and second locking members are provided internal of the surface cleaning apparatus.

In some embodiments, the cyclone bin assembly lock may further comprise a bin release actuator provided on an exterior of the surface cleaning apparatus.

In some embodiments, the cyclone bin assembly may further comprise a handle and the bin release actuator is provided proximate or on the handle.

In some embodiments, the cyclone bin assembly may have a lower surface that is configured to stand on a horizontal surface when removed from the body.

In some embodiments, the lower surface may be flat and the first locking member may be provided internal of the cyclone bin assembly.

In some embodiments, the first locking member may comprise feet provided on the lower surface and are engageable with the second locking member provided on an upper portion of the body.

In some embodiments, the first locking member may be provided internal of the cyclone bin assembly.

In some embodiments, the first locking member may comprise a locking portion that is moveably between a locked and an unlocked position and may be operatively controlled by a bin release actuator and the second locking member may comprise a stationary member provided on the body.

In some embodiments, the second locking member may extend into a recess in the cyclone bin assembly.

In some embodiments, the first locking member may extend into an air flow conduit of the cyclone bin assembly.

12

In some embodiments, the first locking member may extend downwardly through the cyclone bin assembly and the locking portion may be positioned in the air flow conduit of the cyclone bin assembly.

In some embodiments, the air flow conduit of the cyclone bin assembly may comprise a vortex finder.

In some embodiments, a portion of the cyclone bin assembly lock may be provided in the air flow path.

In some embodiments, one of the first and second locking members may comprise two locking portions that are moveable between a locked and an unlocked position.

In some embodiments, the locking portions may be moveably mounted at a common pivot point.

In some embodiments, the cyclone bin assembly lock may be electrically operated.

In some embodiments, the cyclone bin assembly may further comprise a handle and the surface cleaning apparatus may further comprise a lockout member that disables the cyclone bin assembly lock when the handle is used to carry the surface cleaning apparatus.

In some embodiments, the handle may be moveably mounted with respect to the cyclone bin assembly and may be drivingly connected to a lockout member whereby, when the handle is used to carry the surface cleaning apparatus, the handle moves upwardly and drives the lockout member to a lockout position whereby the cyclone bin assembly lock is disabled.

In some embodiments, the lockout member may be electronically operated.

In some embodiments, the lockout member may comprise a sensor that disables the cyclone bin assembly lock when the sensor determines that the handle is used to carry the surface cleaning apparatus.

In yet another embodiment, there is provided a surface cleaning apparatus comprising:

- (a) a surface cleaning head having a dirty air inlet;
- (b) an upper portion moveably mounted to the surface cleaning head between a storage position and a floor cleaning position;
- (c) a portable cleaning unit removably mounted to the upper portion, the portable cleaning unit comprising a suction motor, an air treatment member and a strap compartment;
- (d) a retractable strap having a first end connected to the portable cleaning unit external the strap compartment and an opposed second end disposed within the strap compartment, the strap moveable between a retracted position, in which at least a portion of the strap is disposed within the strap compartment, and an extended position, in which the at least a portion of the strap is external the strap compartment; and
- (e) an air flow path extending from the dirty air inlet and including a flexible air flow conduit forming at least part of an air flow path from the dirty air inlet to the surface cleaning unit.

In yet another embodiment, there is provided a surface cleaning apparatus having:

- (a) a surface cleaning head having a dirty air inlet;
- (b) an upper portion moveably mounted to the surface cleaning head between a storage position and a floor cleaning position;
- (c) a portable cleaning unit removably mounted to the upper portion, the portable cleaning unit comprising a suction motor and an air treatment member; (d) an air flow path extending from the dirty air inlet and includ-

13

ing a flexible air flow conduit forming at least part of an air flow path from the dirty air inlet to the surface cleaning unit;

- (e) a portable cleaning unit lock having a locked position in which the portable surface cleaning unit is secured to the upper portion and an unlocked position in which the portable surface cleaning unit is removable from the upper portion; and
- (f) a foot pedal mechanism disposed on one of the surface cleaning head and the upper portion, the foot pedal operably connected to the portable cleaning unit lock whereby depressing the foot pedal places the portable cleaning unit lock in the unlocked position.

In yet another embodiment there is provided a surface cleaning apparatus comprising:

- (a) a surface cleaning head having a dirty air inlet;
- (b) an upper portion moveably mounted to the surface cleaning head between a storage position and a floor cleaning position, the upper portion including a rigid lower air flow conduit and a rigid upper air flow conduit that is in fluid communication downstream from the lower air flow conduit and pivotally mounted relative to the lower air flow conduit;
- (c) a portable cleaning unit removably mounted to the upper portion, the portable cleaning unit comprising a suction motor and an air treatment member;
- (d) an air flow path extending from the dirty air inlet to the surface cleaning unit and comprising the lower air flow conduit, the upper air flow conduit and a flexible air flow conduit upstream of the upper air flow conduit.

In yet another embodiment there is provided a surface cleaning apparatus comprising:

- (a) a surface cleaning head having a dirty air inlet;
- (b) an upper portion moveably mounted to the surface cleaning head between a storage position and a floor cleaning position;
- (c) a cleaning unit mounted to the upper portion, the portable cleaning unit comprising a suction motor;
- (d) an air flow path extending from the dirty air inlet to the cleaning unit; and
- (e) a user information display system having a controller, a plurality of sensors connected to the controller, the sensors providing information to the controller based on a machine operating conditions and at least one output member connected to the controller and operable to provide information to a user based on one or more detected machine operating conditions thereby alerting the user of the one or more of the detected machine operating conditions.

In yet another embodiment there is provided a surface cleaning apparatus comprising:

- (a) a surface cleaning head having a dirty air inlet, a rotary brush driven by a brush motor and a battery operatively connected to the brush motor;
- (b) an upper portion moveably mounted to the surface cleaning head between a storage position and a floor cleaning position;
- (c) a portable cleaning unit removably mounted to the upper portion, the portable cleaning unit comprising a suction motor connectable to a power source and an air treatment member;
- (d) an air flow path extending from the dirty air inlet to the surface cleaning unit and including at least the lower air flow conduit, the upper air flow conduit and a flexible air flow conduit forming at least part of an air flow path.

14

In yet another embodiment, which may be used in combination with some or all of the other embodiments described herein, there is provided an upright surface cleaning apparatus having:

- a surface cleaning head having a dirty air inlet;
- an upper portion moveably mounted to the surface cleaning head between a storage position and a floor cleaning position, the upper portion comprising a wand;
- a portable surface cleaning unit removably mounted to the upper portion, the portable cleaning unit comprising a suction motor, an air treatment member and a carry handle;
- an air flow path extending from the dirty air inlet to a clean air outlet and comprising an upstream portion that extends from the dirty air inlet to the surface cleaning unit, the upstream portion of the air flow path comprising the wand and a flexible air flow conduit downstream of the wand; and,
- each of the wand and the portable cleaning unit is separately removable from the upper portion.

The wand may be removable while the portable cleaning unit remains in position on the upper portion and while the wand remains in air flow communication with the portable cleaning unit.

The portable cleaning unit may be removable from the upper portion while maintaining the portable cleaning unit in air flow communication with the surface cleaning head.

A single locking member may secure the wand and the portable cleaning unit on the upper portion. The single locking member may include a single actuator.

The single actuator may include a foot pedal disposed on one of the surface cleaning head and the upper portion.

The single locking member may include a latching mechanism that is configurable in an unlocked position and a locked position. When the latching mechanism is in the unlocked position both the wand and the portable cleaning unit are unlocked and either one of the wand and the portable cleaning unit can be separated from the upper portion.

The portable cleaning unit may include a first engagement portion, the wand may include a second engagement portion and the latching mechanism may include a first latch member configured to engage the first engagement portion and a second latch member spaced apart from the first latch member. The latching mechanism may be configured to engage the second engagement portion. When the latching mechanism is in the unlocked position the first latch member may be disengaged from the first engagement portion and the second latch member may be disengaged from the second engagement portion.

The first latch member and the second latch member may be moveable in unison with each other.

The second engagement portion may include an aperture in the wand.

The latching mechanism may be biased toward the locked position and wherein separating one of the wand and the portable cleaning unit from the upper portion engages the latch member and automatically returns the single locking member to the locked position and automatically re-locks the other one of the wand and the portable cleaning unit to the upper portion.

When the one of the wand and the portable cleaning unit has been separated from the upper portion and the single locking member has been returned to the unlocked position the other one of the wand and the surface cleaning apparatus can be separated from the upper portion.

15

The surface cleaning head may have a forward direction of motion and the portable cleaning unit is removably mounted to a front side of the upper portion.

The air treatment member may include a cyclone bin assembly and the cyclone bin assembly may be removable while the portable cleaning unit is mounted to the upper section.

The upper portion may include first and second portions that are part of the air flow path. The second portion may be rotatable relative to the first portion about an axis that intersects a longitudinal axis of at least one of the first and second portions.

The flexible air flow conduit may include an electrified stretch hose.

An upper section mount and each of the wand and the portable cleaning unit may be removably mounted to the upper section mount.

An up flow duct may be moveably mounted to the surface cleaning head and the upper section mount is provided on the up flow duct.

The portable cleaning unit may be spaced from the surface cleaning head when mounted to the upper portion.

The upper portion may also be rotatably mounted with respect to the surface cleaning head.

The upper section may include an upper section mount. The upper section mount may have an outlet port in fluid flow communication with the dirty air inlet. The wand may be in air flow communication with the outlet port when mounted to the upper section mount and each of the wand and the portable cleaning unit may be removably mounted to the upper section mount.

The wand may be mated with the outlet port when mounted to the upper section mount.

The surface cleaning head may include an electric motor drivingly coupled to a rotary brush. The electric motor may be electrically connected to the surface cleaning unit when the surface cleaning unit is mounted on the upper section and may remain electrically connected to the surface to the surface cleaning unit when the surface cleaning unit is removed from the upper portion and the wand remains moveably mounted to the surface cleaning head.

The electric connection between the electric motor and the surface cleaning unit may be uninterrupted when the upright surface cleaning apparatus is in a first configuration wherein the surface cleaning unit is attached to the upper portion and when the upright surface cleaning apparatus is in a second configuration wherein the wand remains moveably mounted to the surface cleaning head and the surface cleaning unit is detached from the upper portion. The electrical connection between the surface cleaning unit and the electric motor may include an electrified stretch hose.

It will be appreciated by a person skilled in the art that a surface cleaning apparatus may embody any one or more of the features from one or more of the embodiments contained herein and that the features from one or more suitable embodiments may be used in any particular combination or sub-combination.

BRIEF DESCRIPTION OF THE DRAWINGS

The drawings included herewith are for illustrating various examples of articles, methods, and apparatuses of the teaching of the present specification and are not intended to limit the scope of what is taught in any way.

In the drawings:

FIG. 1 is a front perspective view of a surface cleaning apparatus in the storage position;

16

FIG. 2 is a rear perspective view of the surface cleaning apparatus of FIG. 1;

FIG. 3 is a front perspective view of the surface cleaning apparatus of FIG. 1 in a floor cleaning position;

FIG. 4 is a cross sectional perspective view taken along line F4-F4 in FIG. 1;

FIG. 5 is cross sectional view taken along line F5-F5 in FIG. 2 with the portable surface cleaning unit being installed on the upper portion;

FIGS. 6-15 are perspective views of the surface cleaning apparatus of FIG. 1 in different cleaning configurations;

FIG. 16 is a perspective view of the surface cleaning apparatus of FIG. 1 with a power tool attached to the wand;

FIG. 17 is a partially exploded perspective view of the surface cleaning apparatus of FIG. 1;

FIG. 18 is a partially exploded perspective view of the surface cleaning apparatus of FIG. 1;

FIG. 19 is a partially exploded perspective view of the surface cleaning apparatus of FIG. 1 with an alternate embodiment of a filter;

FIG. 20 is a perspective view of a cyclone bin assembly with a first embodiment of a carrying strap;

FIG. 21 is a cross-sectional view taken along line 21-21 in FIG. 20;

FIG. 22 is a side view of the cyclone bin assembly of FIG. 20;

FIG. 23 is a perspective view of the cyclone bin assembly of FIG. 20 with the strap extended;

FIG. 24 is the cross-sectional view of FIG. 1 with the strap extended;

FIG. 25 is a perspective view of a cyclone bin assembly with another embodiment of a carrying strap;

FIG. 26 is the perspective view of FIG. 25 with the strap extended;

FIG. 27 is a cross sectional view taken along line 27-27 in FIG. 27;

FIG. 28A is a perspective view of a portion of the surface cleaning apparatus of FIG. 1;

FIG. 28B is a perspective view of another portion of the surface cleaning apparatus of FIG. 1;

FIG. 29A is a schematic representation of the surface cleaning apparatus of FIG. 1 with a surface cleaning unit unlocked;

FIG. 29B is an enlarged view of a portion of FIG. 29A;

FIG. 30A is the schematic view of FIG. 29A with the surface cleaning unit locked;

FIG. 30B is an enlarged view of a portion of FIG. 30A;

FIG. 31A is a side view of another embodiment of a surface cleaning apparatus in an upright position;

FIG. 31B is the side view of FIG. 31A with the surface cleaning apparatus in a use position;

FIG. 32A is an enlarged view of a portion of FIG. 31A;

FIG. 32B is an enlarged view of a portion of FIG. 31B;

FIG. 33A is a side view of another embodiment of a surface cleaning apparatus in an upright position;

FIG. 33B is the side view of FIG. 33A with the surface cleaning apparatus in a use position;

FIG. 34A is an enlarged view of a portion of FIG. 33A;

FIG. 34B is an enlarged view of a portion of FIG. 33B;

FIG. 35A is a side view of another embodiment of a surface cleaning apparatus in an upright position;

FIG. 35B is the side view of FIG. 35A with the surface cleaning apparatus in a use position;

FIG. 36A is an enlarged view of a portion of FIG. 35A;

FIG. 36B is an enlarged view of a portion of FIG. 35B;

FIG. 37 is a rear perspective view of another embodiment of a surface cleaning apparatus;

17

FIG. 38 is an enlarged view of a portion of FIG. 37;
 FIG. 39 is a cross-sectional view of the portion the surface cleaning apparatus of FIG. 38, taken along line 39-39 in FIG. 38;
 FIG. 40 is an enlarged view of a portion of FIG. 37 with a pedal in a depressed position;
 FIG. 41 is a cross-sectional view of the portion the surface cleaning apparatus of FIG. 40, taken along line 41-41 in FIG. 38;
 FIG. 42 is the cross-sectional view of FIG. 39, with a locking mechanism in an unlocked configuration;
 FIG. 43 is the cross-sectional view of FIG. 42 with a surface cleaning unit removed;
 FIG. 44 is the cross-sectional view of FIG. 39, with a lower wand portion partially removed;
 FIG. 45 is the cross-sectional view of FIG. 39 with the lower wand portion removed;
 FIG. 46A is a cross-sectional view of another embodiment of a surface cleaning apparatus;
 FIG. 46B is the cross-sectional view of FIG. 46A with a cyclone bin assembly detached;
 FIG. 47A is a cross-sectional view of another embodiment of a surface cleaning apparatus;
 FIG. 47B is the cross-sectional view of FIG. 47A with a cyclone bin assembly detached;
 FIG. 48A is a cross-sectional view of another embodiment of a surface cleaning apparatus;
 FIG. 48B is the cross-sectional view of FIG. 48A with a cyclone bin assembly detached;
 FIG. 49 is a front perspective view of an embodiment of a cyclone bin assembly;
 FIG. 50 is a cross-sectional view of the cyclone bin assembly of FIG. 49, taken along line 50-50 in FIG. 49;
 FIG. 51 is a cross-sectional view of the cyclone bin assembly of FIG. 49, taken along line 51-51 in FIG. 49;
 FIG. 52 is a cross-sectional view of the cyclone bin assembly of FIG. 51 with a door open;
 FIG. 53 is a cross-sectional view of an embodiment of a cyclone bin assembly;
 FIG. 54 is a perspective view of a portion of the surface cleaning apparatus of FIG. 1;
 FIG. 55A is the perspective view of FIG. 54 with a collar member in an unlocked position;
 FIG. 55B is another perspective view of the portion of the surface cleaning apparatus of FIG. 54 with an upper wand portion detached;
 FIG. 56 is a rear perspective view of the portion of the surface cleaning apparatus of FIG. 54;
 FIG. 57 is a perspective view of a hinge member of the surface cleaning apparatus of FIG. 1;
 FIG. 58 is the hinge member of FIG. 57 in a bent configuration;
 FIG. 59 is a perspective view of the portion of the surface cleaning apparatus of FIG. 54 with an alternate embodiment of an air flow conduit;
 FIG. 60 is a perspective view of a handle portion of the surface cleaning apparatus of FIG. 1;
 FIG. 61 is a perspective view of the handle of FIG. 60 with a portion of the housing removed;
 FIG. 62 is a perspective view of a portion of the surface cleaning apparatus of FIG. 1;
 FIGS. 63 and 64 are perspective views of another embodiment of a surface cleaning apparatus;
 FIG. 65 is a perspective view of a portion of the surface cleaning apparatus of FIG. 1;
 FIG. 66 is a perspective view of a portion of the surface cleaning apparatus of FIG. 1;

18

FIG. 67 is a cross-sectional perspective view taken along line 67-67 in FIG. 66;
 FIG. 68 is a perspective view of a portion of the surface cleaning apparatus of FIG. 1 showing an embodiment of an electrified hose coupling;
 FIG. 69 is the perspective view of FIG. 68 with the hose coupling in a different position;
 FIG. 70 is a perspective view of a portion of the surface cleaning apparatus of FIG. 1 showing an alternate embodiment of an electrified hose coupling;
 FIG. 71 is the perspective view of FIG. 68 with the hose coupling in a different position;
 FIG. 72 is a schematic diagram of an embodiment of a switching circuit;
 FIGS. 73A and 73B are schematic diagrams of another embodiment of a switching circuit;
 FIG. 74 is a schematic diagram of another embodiment of a switching circuit;
 FIG. 75A is a schematic diagram of an embodiment of a connecting circuit;
 FIG. 75B is a schematic diagram of another embodiment of a connecting circuit;
 FIG. 76 is a perspective view of an embodiment of a surface cleaning head;
 FIG. 77 is the perspective view of FIG. 76 with a portion of the housing removed;
 FIGS. 78A and 78B are schematic representations of an embodiment of a locking mechanism;
 FIGS. 79A and 79B are schematic representations of an alternate embodiment of a locking mechanism;
 FIGS. 80A and 80B are schematic representations of an alternate embodiment of a locking mechanism;
 FIG. 81 is a perspective view of an alternate embodiment of a surface cleaning apparatus; and
 FIG. 82 is a schematic representation of an information system.

DETAILED DESCRIPTION

Various apparatuses or processes will be described below to provide an example of an embodiment of each claimed invention. No embodiment described below limits any claimed invention and any claimed invention may cover processes or apparatuses that differ from those described below. The claimed inventions are not limited to apparatuses or processes having all of the features of any one apparatus or process described below or to features common to multiple or all of the apparatuses described below. It is possible that an apparatus or process described below is not an embodiment of any claimed invention. Any invention disclosed in an apparatus or process described below that is not claimed in this document may be the subject matter of another protective instrument, for example, a continuing patent application, and the applicants, inventors or owners do not intend to abandon, disclaim or dedicate to the public any such invention by its disclosure in this document.

General Description of an Upright Vacuum Cleaner

Referring to FIGS. 1-3, a first embodiment of a surface cleaning apparatus 1 is shown. In the embodiment shown, the surface cleaning apparatus is an upright vacuum cleaner. In alternate embodiments, the surface cleaning apparatus may be another suitable type of surface cleaning apparatus, such as a canister type vacuum cleaner, and hand vacuum cleaner, a stick vac, a wet-dry type vacuum cleaner or a carpet extractor.

In the illustrated example, the surface cleaning apparatus 1 includes an upper portion or support structure 2 that is

movably and drivingly connected to a surface cleaning head 3. A surface cleaning unit 4 is mounted on the upper portion 2. The surface cleaning apparatus 1 also has at least one dirty air inlet 5, at least one clean air outlet 6, and an air flow path or passage extending therebetween. In the illustrated example, the air flow path includes at least one flexible air flow conduit member (such as a hose 7 or other flexible conduit). Alternatively, the air flow path may be formed from rigid members.

At least one suction motor and at least one air treatment member are positioned in the air flow path to separate dirt and other debris from the airflow. The suction motor and the air treatment member may be provided in the upper portion and/or the surface cleaning head of an upright surface cleaning apparatus. Preferably, the suction motor and the air treatment member are provided in a removable surface cleaning unit. The air treatment member may be any suitable air treatment member, including, for example, one or more cyclones, filters, and bags, and preferably the at least one air treatment member is provided upstream from the suction motor. Preferably, as exemplified in FIG. 4, the surface cleaning unit includes both the suction motor 8, in a motor housing 12 and an air treatment member in form of a cyclone bin assembly 9. The motor housing can include at least one removable or openable door 13 which may allow a user to access the interior of the motor housing 12, for example to access the motor 8, a filter or any other component within the housing 12. The cyclone bin assembly 9 includes a cyclone chamber 10 and a dirt collection chamber 11.

Optionally, the surface cleaning unit 4 may be a portable surface cleaning unit and may be detachable from the upper portion (FIG. 5). In such embodiments, the surface cleaning unit 4 may be connected to the upper portion 2 by a mount apparatus 14 that allows the surface cleaning unit 4 to be detached from the upper section 2. It will be appreciated that a portable surface cleaning unit 4 could be carried by a hand of a user, a shoulder strap or the like and could be in the form of a pod or other portable surface cleaning apparatus. All such surface cleaning apparatus are referred to herein as a hand carryable surface cleaning apparatus.

In the embodiment shown, the surface cleaning head 3 includes the dirty air inlet 5 in the form of a slot or opening 15 (FIG. 4) formed in a generally downward facing surface of the surface cleaning head 3. From the dirty air inlet 5, the air flow path extends through the surface cleaning head 3, and through an up flow conduit 16 (FIG. 2) in the upper portion 2 to the surface cleaning unit 4. In the illustrated example, the clean air outlet 6 is provided in the front of the surface cleaning unit 4, and is configured to direct the clear air in a generally lateral direction, toward the front of the apparatus 1.

A handle 17 is provided on the upper portion 2 to allow a user to manipulate the surface cleaning apparatus 1. Referring to FIGS. 1 and 3, the upper portion extends along an upper axis 18 and is moveably mounted to the surface cleaning head 3. In the illustrated example, the upper portion 2 is pivotally mounted to the surface cleaning head via a pivot joint 19. The pivot joint 19 may be any suitable pivot joint. In this embodiment, the upper portion 2 is movable, relative to the surface cleaning head 3, between a storage position (FIG. 1), and a use or floor cleaning position (FIG. 3). In the floor cleaning position the upper portion 2 may be inclined relative to the surface being cleaned, and an angle 19 between a plane 20 parallel to the surface and the upper axis 18 may be between about 20 and about 85°.

Alternatively, or in addition to being pivotally coupled to the surface cleaning head, the upper portion may also be

rotatably mounted to surface cleaning head. In this configuration, the upper portion, and the surface cleaning unit supported thereon, may be rotatable about the upper axis. In this configuration, rotation of the upper portion about the upper axis may help steer the surface cleaning head across the floor (or other surface being cleaned). It will be appreciated that the forgoing discussion is exemplary and that an upright vacuum cleaner may use a surface cleaning head and upper portion of any design and they may be moveably connected together by any means known in the art.

Handle/Cleaning Wand Construction

The following is a description of a cleaning wand that may be used by itself in any surface cleaning apparatus or in any combination or sub-combination with any other feature or features disclosed herein.

As exemplified, the air flow path between the surface cleaning head 3 and the surface cleaning unit 4 may include a bendable hollow conduit or wand member 100, which may be used in combination with a flexible hose portion 7. Preferably, the hose 7 is extensible and more preferably is elastically or resiliently extensible.

Referring to FIG. 2, the wand member 100 includes an upper wand portion 101 and a lower wand portion 102. The upper and lower wand portions 101, 102 are connected to each other via a connection, e.g., a hinge 103 member, which allows relative movement between the upper and lower wand portions 102, 103. Optionally, the hinge member 103 can be configured to form part of the air flow path and to provide fluid communication between the upper and lower wand portions 101, 102, as well as provide a pivoting, mechanical linkage. For example, upper and lower wand portions 101, 102 may be moveably connected to each other by providing a pivot joint that permits the upper and lower wand portions 101, 102 to be connected in air flow communication or by each wand portion having projections that are pivotally connected to each other and with a flexible hose to provide the air flow communication between the wand portions. Alternatively, the air flow path can be external to the hinge. The handle 17 is provided toward the top of the upper portion 2 and is attached to the upper or downstream end of the upper wand portion 101. In the illustrated embodiment, the handle 17 includes a hand grip portion 21 that is configured to be grasped by a user. The hinge member 103 can be locked in a straight configuration (FIG. 9) and can be unlocked to allow the upper wand portion 101 to pivot relative to the lower wand member 102 (FIG. 10).

In the illustrated example, the upper and lower wand portions 101, 102 and the handle 17 are hollow tube-like conduit members that form part of the air flow path and can carry at least some of the weight of the surface cleaning apparatus 4. The wand 100 is also configured to transfer driving and steering forces between the handle 17 and the surface cleaning head 3.

The upper and lower wand portions 101, 102 may be made of any suitable material that can withstand the weight of the surface cleaning apparatus 4 and the driving and steering forces, including, for example, plastic, metal and the like. Optionally, upper and lower wand portions 101, 102 may be formed from the same material. Alternatively, they may be formed from different materials.

Referring to FIG. 9 the distance 104 between the surface cleaning head 3 and the upper end of the handle 17 defines an upper portion height. Preferably, the upper portion height 104 can be selected so that the handle 17 is positioned so to be grasped by users of varying heights. The upper portion height 104 may be between, for example, about 35 inches and about 60 inches, and preferably is between about 40

inches and about 50 inches. In the illustrated example, the upper portion height **104** is between about 41 inches and about 45 inches.

The upper wand portion **101** defines an upper wand length **105** and the lower wand portion **102** defines a lower wand length **106**. The upper and lower wand lengths **105**, **106** may be the same, or may be different. Preferably, each of the upper and lower wand lengths **105**, **106** are between about 15% and about 80% of the upper portion height **104**. Altering the relative lengths of the upper and lower wand portions may change the position of the hinge **103** relative to the surface cleaning head **3**.

In one aspect of the teachings described herein, which may be used in combination with any one or more other aspects, the upright vacuum cleaner **1** may be operable in a variety different functional configurations or operating modes. The versatility of operating in different operating modes may be achieved by permitting the surface cleaning unit to be detachable from the upper portion. Alternatively, or in addition, further versatility may be achieved by permitting portions of the vacuum cleaner to be detachable from each other at a plurality of locations in the upper portion, and re-connectable to each other in a variety of combinations and configurations.

In the example illustrated, mounting the surface cleaning unit **4** on the upper portion **2** increases the weight of the upper portion **2** and can affect the maneuverability and ease of use of the surface cleaning apparatus. With the surface cleaning unit **4** attached, the vacuum cleaner **1** may be operated like a traditional upright style vacuum cleaner, as illustrated in FIGS. 1-3.

Alternatively, in some cleaning situations the user may preferably detach the surface cleaning unit **4** from the upper portion **2** and choose to carry the surface cleaning unit **4** (e.g. by hand or by a strap) separately from the upper portion **2**, while still using the upper portion **2** to drivingly maneuver the surface cleaning head **3**. When the surface cleaning unit **4** is detached, a user may more easily maneuver the surface cleaning head **3** around or under obstacles, like furniture and stairs.

To enable the vacuum suction generated by the surface cleaning unit **4** to reach the surface cleaning head **3** when the surface cleaning unit **4** is detached from the support structure **2**, the airflow connection between the surface cleaning head **3** and the cleaning unit **4** is preferably at least partially formed by a flexible conduit, such as the flexible hose **7**. The use of a flexible conduit allows a user to detach the surface cleaning unit **4** and maintain a flow connection between the portable surface cleaning unit **4** and the surface cleaning head **3** without having to reconfigure or reconnect any portions of the airflow conduit **16** (FIG. 6).

Referring to FIG. 6, when the surface cleaning apparatus **1** is in use, a user may detach the surface cleaning unit **4** from the upper portion **2** without interrupting the airflow communication between the cleaning unit **4** and the surface cleaning head **3**. This allows a user to selectively detach and re-attach the cleaning unit **4** to the support structure **2** during use without having to stop and reconfigure the connecting hoses **7** or other portions of the airflow conduit **16**.

FIGS. 6, 9 and 10 illustrate a configuration in which the vacuum cleaner **1** can be operated with the surface cleaning unit **4** detached from the upper portion **2** and the air flow path between the surface cleaning unit **4** and the surface cleaning head **3** remains intact. FIG. 9 shows the upper portion **2** in a straight configuration. FIG. 10 shows the

upper portion **2** in an optional bent configuration. In both configurations, the surface cleaning head **3** is operable to clean the floor.

Alternatively, in some cleaning operations the user may wish to reconfigure portions of the air flow path to provide a surface cleaning apparatus with a desired configuration. For example, in another configuration, as exemplified in FIG. 8, the wand portion of the upper section **2** is removed and the upstream end of the handle **17**, and the handle **17** is coupled directly to the surface cleaning head **3**. This configuration may be useful when cleaning stairs or other surfaces that are elevated. This is another example of a floor or surface cleaning operating mode.

In addition to being operable to clean floors or surfaces, the vacuum cleaner may be operated in a variety of cleaning modes that do not include use of the surface cleaning head, and may be generally described as above floor cleaning modes. This can generally include cleaning furniture, walls, drapes and other objects as opposed to cleaning a large, planar surface.

In one example of an above floor cleaning mode, as exemplified in FIG. 7, the surface cleaning unit **4** can remain mounted on the upper portion **2**. This eliminates the need for the user to separately support the weight of the surface cleaning unit **4**. In the illustrated configuration, the upstream end of the handle **17** is separated from the downstream end of the upper wand portion **100**. In this configuration the upstream end **22** of the handle **17** can function as the dirty air inlet for the vacuum cleaner **1**. Optionally, accessory tools, such as wands, crevasse tools, turbo brushes, hoses or other devices may be coupled to the upstream end **22** of the handle **17**.

In another example of an above floor cleaning mode, as exemplified in FIG. 11, the surface cleaning unit **4** can remain mounted on the upper portion **2** and the upper wand portion **101** can be detached from the hinge **103** to provide an extended wand for above floor cleaning. This configuration may help extend the reach of a user, as compared to the configuration of FIG. 7. Optionally, additional accessory tools may be coupled to the upstream end **25** of the upper wand portion **101**, including for example a crevice tool (FIG. 15), a cleaning brush **26** (optionally an electrically powered brush or an air driven turbo brush, see FIG. 14) and any other type of accessory including a power tool such as a sander **27** (FIG. 16).

In another example of an above floor cleaning mode, as exemplified in FIG. 12, the surface cleaning unit **4** can be detached from the upper portion **2**, and substantially all of the upper portion **2** can be detached from the surface cleaning head **3**. In this configuration, both the upper and lower wand portions **101**, **102** co-operate to further extend the user's reach, as compared to the configurations of FIGS. 7 and 11. Optionally, additional accessory tools may be coupled to the upstream end **28** of the upper portion **2**.

In another example of an above floor cleaning mode, as exemplified in FIG. 13, the surface cleaning unit **4** can be detached from the upper portion **2** and the handle **17** can be detached from the upper portion **2**.

Optionally, one or more auxiliary support members, including for example a wheel and a roller, can be provided on the rear of the surface cleaning apparatus and/or the upper portion and configured to contact the floor (or other surface) when the upper portion is inclined or placed close to the surface (see FIG. 10). Providing an auxiliary support member may help carry some of the weight of the surface cleaning unit and/or upper portion when in a generally horizontal configuration. The auxiliary support member may

also help the upper portion 2 and/or surface cleaning unit 4 to roll relatively easily over the floor when in the horizontal position. This may help a user to more easily maneuver the upper portion and/or surface cleaning unit under obstacles, such as a bed, cabinet or other piece of furniture. In the illustrated embodiment the auxiliary support member is a roller 30 provided on the back side of the lower wand portion 102.

Removable Cyclone

The following is a description of a removable cyclone that may be used by itself in any surface cleaning apparatus or in any combination or sub-combination with any other feature or features disclosed herein.

Optionally, the cyclone bin assembly 9 can be detachable from the motor housing 12. Providing a detachable cyclone bin assembly 9 may allow a user to carry the cyclone bin assembly 9 to a garbage can for emptying, without needing to carry or move the rest of the surface cleaning apparatus 1. Preferably, the cyclone bin assembly 9 can be separated from the motor housing 12 while the surface cleaning unit 4 is mounted on the upper portion 2 and also when the surface cleaning unit 4 is separated from the upper portion 2. Referring to FIG. 17, in the illustrated embodiment the cyclone bin assembly 9 is removable as a closed module, which may help prevent dirt and debris from spilling out of the cyclone bin assembly 9 during transport.

In the illustrated embodiment, removing the cyclone bin assembly 9 reveals a pre-motor filter chamber 31 that is positioned in the air flow path between the cyclone bin assembly 9 and the suction motor 8 (see also FIG. 4). One or more filters can be provided in the pre-motor filter chamber 31 to filter the air exiting the cyclone bin assembly 9 before it reaches the motor 8. In the illustrated example, the pre-motor filter includes a foam filter 32 and a downstream felt layer 33 positioned within the pre-motor filter chamber 31. Preferably, the filters 32, 33 are removable (FIG. 18) to allow a user to clean and/or replace them when they are dirty. Optionally, part or all of the sidewalls 34 of the pre-motor filter chamber or housing 31 can be at least partially transparent so that a user can visually inspect the condition of the filters 32, 33 without having to remove the cyclone bin assembly 9.

Filter Status Indicator Mechanism

The following is a description of a filter status indicator that may be used by itself in any surface cleaning apparatus or in any combination or sub-combination with any other feature or features disclosed herein.

Optionally, one or both of the filters 32, 33 can be provided with an indicator mechanism to alert a user that the filters 32, 33 are dirty and require cleaning. If the filters are installed in a stacked formation as exemplified, then only the upstream filter may be provided with the filter status indicator. Preferably, the indicator mechanism is provided on an exposed portion of the filters 32, 33 that is visible to the user when a filter chamber is opened to access the filters 32, 33 are installed, and more preferably the indicator mechanism is provide on the upstream side 35 (FIG. 18) of the filter 32. Preferably, the upstream side 35 of the filter 32 is visible when the filter housing is opened, e.g., the cyclone bin assembly is removed, and accordingly a user will be advised of the status of the filters when a user removes the cyclone bin assembly 9. Optionally the filter status indicator may be visible when the cyclone bin assembly 9 is attached if all or part of the sidewall 34 is transparent and/or includes an inspection window.

The indicator mechanism can be any type of apparatus or feature that provides a visual indication that the upstream

side 35 of the filter 32 is dirty or getting dirty. For example, the indicator mechanism may include a pattern or graphic that is visible when the surface 35 is clean, but becomes obscured when dirt accumulates on the surface 35. When the graphic is no longer visible, a user is alerted that the filter 32 requires maintenance. Alternatively, the indicator mechanism may be a graphic element that becomes visible when the filter 32 is dirty, instead of disappearing or becoming obscured as described above.

Referring to FIG. 19, one embodiment of a filter 32a that includes and indicator mechanism 36 is shown. The filter 32a is generally similar to filter 32, and can be used in combination with the surface cleaning apparatus 1. In the illustrated embodiment, the indicator mechanism 36 is a graphic element that includes the text "Wash Me" in addition to a plurality of cross hatch lines. Any particular graphic may be used. Preferably, the graphics 36 are formed from a material that has the same colour as a clean, unsoiled filter 32a (typically white, but may be any suitable colour), but that has different dirt absorption properties than the filter material used to make filter 32a (typically a foam material). For example, if the filter 32a is formed from a generally porous foam-like material, the portion containing the graphics 36 may be formed from a less porous material or it may be treated to be less porous, such as by silk-screening graphic 36 onto the upstream surface of the filter. In this configuration, the portion of filter 32a containing the graphics 36 may be less permeable than the rest of the filter 32a, and dirt may have less penetration into the upstream side of this portion of the filter. As a result, the portion with the graphics may remain "whiter" than the foam filter 32a after being exposed to a dirty air flow. When the colour of the foam 32a darkens due to the accumulated dirt, the contrast between the filter 32a and the graphics 36 increases, thereby making the graphics 36 visible to the user.

In this configuration, when the filter 32a is unsoiled, the graphics 36 will be the same colour as the filter 32a, and will not be visually obvious (i.e. the contrast between the graphics 36 and the filter 32a will be very slight). In this state, the filter 32a will appear like a blank foam filter. When the surface cleaning apparatus is in use, dirt and debris may accumulate in the upstream side 35a of the filter 32a, preferentially in the part that does not contain the graphics, thereby revealing the graphics 36.

Carrying Strap for Surface Cleaning Unit

The following is a description of a carry strap and handle construction that may be used by itself in any surface cleaning apparatus or in any combination or sub-combination with any other feature or features disclosed herein.

As exemplified in FIGS. 9 and 10, a carrying strap 540 may be provided on the surface cleaning unit 4. The carrying strap 540 may allow a user to support the surface cleaning unit 4 from the user's shoulder when the surface cleaning unit 4 is detached from the upper portion 2. Providing such a strap 540 may help reduce the weight a user must carry in the user's hands, and may allow a user to carry the surface cleaning unit 4 while keeping the user's hands free to perform other tasks (e.g. manipulate the upper portion 2 and/or move furniture out of the way of a surface cleaning head). The strap 540 may be of any suitable configuration, and may be formed from any suitable material, including, for example, extensible or elastic material, non-elastic material, webbing, fabric, elastic film and/or strands and non-woven material.

The strap 540 may be attached to the surface cleaning unit 4 at any suitable location. For example, the strap 540 can be attached to the cyclone bin assembly 9. When the cyclone

bin assembly 9 is mounted on the motor housing 12, the strap 540 can be used to carry the entire surface cleaning unit 4 (FIG. 10). When the cyclone bin assembly 9 is detached from the motor housing 12, the strap 540 can remain with the cyclone bin assembly 9, and can be used to carry the cyclone bin assembly 9 for emptying. Alternatively, the strap 540 may be connected to the motor housing 12 such that the strap 540 remains with the motor housing 12 when the cyclone bin assembly 9 is removed. In yet another alternate configuration, the strap 540 may be connected so that one end of the strap is attached to the cyclone bin assembly 9 and the other is attached to the motor housing 12. In this configuration, the strap 540 may tether the cyclone bin assembly 9 to the motor housing 12. If the cyclone bin assembly 9 is to be removed for emptying, the entire surface cleaning unit 4 may be moved proximate the garbage can, and/or one or both ends of the strap 540 may be detached to free the cyclone bin assembly 9 from the motor housing 12.

Optionally, the strap 540 can be a retractable strap that can be stored in a retracted position (FIG. 9) when not in use, and then withdrawn to an extended position (FIG. 10) when required. Providing a retractable strap 540 may help provide a relatively long strap (sufficient to reach a user's shoulder) when needed, and may help eliminate any loose hanging slack when the strap 540 is not in use. Eliminating the loose hanging strap/slack when not in use may help reduce the likelihood that the strap 540 will be tangled or caught on portions of the surface cleaning apparatus 1 or surrounding objects. Preferably, the strap 540 can be retracted into a suitable strap storage mechanism.

Referring to FIG. 20, the cyclone bin assembly 9 is illustrated including one embodiment of a strap storage mechanism 541. In this embodiment, the strap storage mechanism includes a strap compartment 542 mounted to the rear of the cyclone bin assembly 9, external the cyclone chamber 10 and dirt collection chamber 11. Referring to FIG. 21, in this embodiment the front sidewall 543 of the strap compartment 542 is integral with a portion of the sidewall 544 of the cyclone chamber 10.

The strap is preferably attached to the surface cleaning unit so as to permit lid 546 to be opened without interference from the strap. As exemplified, the strap 540 includes a first end 545 that is connected to a lid portion 546 of the cyclone bin assembly 9 and a second end 545a that is fastened inside the strap compartment 542. In this configuration, when the lid 546 is moved to an open position (FIG. 22) the first end 545 of the strap 540 may travel with the lid 546. This may allow the lid 546 to be freely opened without interference from the strap 540. Alternatively, the first end 545 of the strap 540 may be coupled to the sidewall 543 or other portions of the cyclone bin assembly 9, and need not be moveable/openable with the lid 546. In such configurations, the first end 545 of the strap 540 may be detachable so that it can be decoupled to allow the lid 546 to open.

Portions of the strap 540 between the first and second ends 545, 545a may extend over any suitable portions of the lid 546 of the cyclone bin assembly 9. In the illustrated embodiment, the lid 546 includes a handle 547 and the strap 540 passes over the handle. The handle 547 may be of any suitable configuration and may be used to carry the entire surface cleaning apparatus 1 (when the surface cleaning unit 4 is attached to upper portion 2), the surface cleaning unit 4 (when detached from the upper portion 2) and the cyclone bin assembly 9 (when detached from the motor housing 12). The handle 547 may include a hand grip portion 548 that is configured to be grasped by the user. Positioning the strap

540 in proximity to the hand grip portion 548 may make it easy for a user to transfer from the hand grip 548 to the strap 540.

Optionally, the lid 546 can include a strap guide for guiding and optionally at least partially restraining the strap 540. Providing a strap guide may help reduce the likelihood that the strap 540 will shift from its desired location and/or slip off of the edge of the lid 546. The strap guide may be of any suitable configuration, including for example, a channel or groove, retaining clips and other fasteners.

In the illustrated embodiment, the cyclone bin assembly 9 includes a strap guide in the form of a channel 549 (FIG. 23) formed on the lid 546. The channel 549 extends along the upper surface of the handle 48 and is sized to receive the strap 540. In the illustrated embodiment, the channel 549 has a width 550 that is preferably equal to or greater than the width 551 of the strap 540, and a depth 552 that is preferably equal to or greater than the thickness 553 of the strap 540, but may be less than the thickness 553. When contracted (FIG. 22) the strap 540 is nested within the channel 549.

Optionally, to assist with removal of the strap 540 from the channel 549, the handle 547 may be provided with one or more strap access features that may allow a user to access one or both the sides of the strap 540 when it is seated on the handle, e.g., it is seated within the channel 549. In the illustrated embodiment, the channel 549 includes strap access features in the form of a finger cut-out groove 551 extending generally perpendicular to the hand grip portion 549. The groove 551 allows a user to place their fingers under the strap to grasp the edges of the strap 540 and pull it upwardly thereby removing it from the channel 549. Alternatively, the groove 551 may be in any suitable orientation.

Optionally, as exemplified, at least a portion 552 of the strap 540 is resilient or elastically extensible to allow the strap 540 to be extended and retracted as required. In this configuration, the resilient nature of portion 552 will urge the strap 540 toward its retracted position. Optionally, the entire strap 540 may be formed from a resiliently extensible material.

In the retracted position, some or all of the resilient portion 552 can be accumulated within the strap compartment 542 (FIG. 21). The strap 540 may be configured so that the resilient portion 552 tends to fold or accordion onto itself when contracted, or may simply contract into a shirred configuration. When entering and exiting the strap compartment 542, the strap 540 passes through an opening 553 that is sized to receive the strap 540. The opening 553 can be generally open and free of obstacles (as illustrated) to allow free passage of the strap 540. Alternatively, the opening 553 may snugly receive the strap 540 and/or may include one or more guide members or flow metering members to engage the strap 540 as it passes through the opening 553. When in the extended position (FIG. 24), portions of the resilient portion 552 are drawn out of the strap compartment 542 as the strap 540 extends.

In this embodiment, the strap 540 is not locked or otherwise retained in the contracted position. To extend the strap 540, a user may simply grasp an exposed portion of the strap 540 and pull. The resilient portion 552 will yield to the user's applied force, and the strap may expand to its extended position (FIG. 23). Similarly, in this embodiment the strap 540 is not locked or retained in its extended position. When a user releases the strap 540, the resilient portion 552 will contract, nesting itself within the strap compartment 542 and thereby retracting the strap 540. Alternatively, a locking mechanism (e.g. a clamp or clip)

may be provided to inhibit movement of the strap 540 and to hold the strap 540 in its contracted or extended positions, or both, until the locking mechanism is released. Providing a locking mechanism may allow a user to release the strap 540, for example when temporarily resting the surface cleaning unit 4 on a surface, without the strap 540 automatically retracting.

Referring to FIG. 25, the cyclone bin assembly 9 is illustrated with an alternate embodiment of a strap storage mechanism 541. In this embodiment, the strap storage mechanism includes a strap reel 554 coupled to the rear face of the cyclone bin assembly 9. In this embodiment, the strap 540 is wound within the reel 554 and is movable between a retracted position (FIG. 25) and an extended position (FIG. 26) by unwinding and/or winding the reel 554.

The reel 554 may be any suitable reel mechanism, and in the example illustrated includes an internal spool 555 about which the strap 540 is wound. The spool 555 can be biased or driven using any suitable mechanism in the winding direction of the spool 555, so that the strap 540 is automatically retracted within the reel 554 absent an external force. For example, the spool 55 may be sprung or spring biased to return to its wound position. Alternately, a motor may be provided to wind and or unwind the strap on the reel.

Like the previous embodiment, in this configuration the strap 540 may be freely extendable when pulled, and may tend to automatically retract when released. Alternatively, a suitable locking mechanism may be provided, e.g., at the outlet 556 of the reel 554 to selectively hold the strap 540 in its retracted and/or an extended configuration.

Surface Cleaning Unit Mount

Referring to FIGS. 28A and 28B, the surface cleaning unit 4 may be detachable or removable from the upper portion 2, and may be secured thereto using any suitable mounting apparatus. The mounting apparatus may include a retaining mechanism for supporting and positioning the surface cleaning unit 4 relative to the upper portion 2, and may include a locking mechanism for securing the surface cleaning unit 4 to the upper portion 2.

The following is a description of a mount for the portable surface cleaning unit that may be used by itself in any surface cleaning apparatus or in any combination or sub-combination with any other feature or features disclosed herein.

Optionally, the mount for retaining the surface cleaning unit on the upper portion may include a guide member to assist in replacing the surface cleaning unit on the upper portion and/or to laterally support the surface cleaning unit when mounted on the upper portion.

In the illustrated embodiment, a mounting apparatus 60 includes a spine member 61 provided on the back surface of the cyclone bin assembly 9 and a corresponding or mating channel portion 62 on the upper portion 2. The channel 62 includes a bottom wall 63 for engaging and supporting a bottom surface 64 on the spine 61, and sidewalls 65 for engaging corresponding side surfaces 66 on the spine 61. When the spine 61 is seated within the channel 62, downward movement of the surface cleaning unit 4 is constrained by bottom wall 63, and lateral movement and rotation of the surface cleaning unit 4 relative to the upper portion 2 is constrained by sidewalls 65.

The bottom wall 63 may be a generally flat surface, and optionally may include one or more alignment or locating members. Providing an alignment member may help a user position the spine 61 appropriately within the channel 62. In the illustrated embodiment, the channel 62 includes a locating member in the form of an aperture 67 in the bottom wall

63 (see the schematic representation in FIG. 29A. The spine 61 (or other portion of the surface cleaning unit 4) includes a mounting pin 68 that is configured to fit within aperture 67.

Referring to the schematic representation of FIGS. 29A and 29B, when a user mounts the surface cleaning unit 4 on the upper portion 2, the mounting pin 68 may be inserted into the aperture 67 to orient and locate the spine 61 relative to the channel 62. As the unit 4 is tilted forwardly, a user may look downwardly so they may see the engagement portion on the bottom wall and therefore align pin 68 with the aperture 76. The surface cleaning unit 4 can then be pivoted rearwardly (see FIGS. 30A and 30B) until the spine 61 is seated properly within the channel 62.

The engagement members (e.g., pin 68 and aperture 67) may be of any desired configuration provided they inter-engage. It will be appreciated that the aperture could be provided on unit 4. If the engagement members have a substantial lateral extent (i.e., in a direction transverse to the forward direction) or two or more are provided, then the engagement members may inhibit lateral movement of the lower end of the spine 61 relative to the channel 62. Alternately or in addition, the sidewalls of the channel may inhibit lateral movement of unit 4 when mounted in the channel.

In addition to, or as an alternative to the alignment and retaining members, the mounting apparatus 60 can also include any suitable locking mechanism for locking the surface cleaning apparatus to the upper portion 2. Referring to FIG. 28A, in the illustrated embodiment the mounting apparatus includes a locking member in the form of a latch 70 on the spine 61 and a corresponding slot 71 in the back wall 72 of the channel 62.

The latch 70 is configured to engage the slot 71 and to prevent the spine 61 from being lifted or moved laterally away from the channel 62. In combination with the other surfaces and features of the spine 61 and channel 62, engaging the latch 70 can prevent removal of the surface cleaning unit 4.

To remove the surface cleaning unit 4, a user can depress the latch release button 73, which may be provided on the spine 61. The latch release button 73 is drivingly connected to the latch member 70 using a connecting linkage. Depressing the release button 73 translates the latch 71 downwardly thereby disengaging the latch 70 from the slot 71. The surface cleaning unit 4 can then be pivoted forward, and then lifted to remove the pin 68 from the aperture 67. The latch release button 73, and linkage connected thereto, can be biased to the locked position (for example using a spring) so that the latch 70 remains locked until triggered by a user.

Automatic Unlocking of the Surface Cleaning Unit

The following is a description of an automatic unlocking system that may be used by itself in any surface cleaning apparatus or in any combination or sub-combination with any other feature or features disclosed herein.

In the illustrated embodiment, the unlocking of the surface cleaning unit 4 is a manual operation. Alternatively, in accordance with one aspect of the teachings described herein, the locking mechanism used to lock the surface cleaning unit 4 to the upper portion 2 may be automatically operable to change state (i.e. locked to unlocked and/or unlocked to locked) based on the configuration of the surface cleaning apparatus 1. For example, the locking mechanism may be automatically disengaged or unlocked when the surface cleaning apparatus 1 is in a surface or floor cleaning position (FIG. 3) and may be automatically locked when the surface cleaning apparatus 1 is in a storage position (FIG. 1). A mechanical, electro-mechanical or electronic

surface cleaning unit lock may be used. This may allow a user to freely remove the surface cleaning unit 4, for example using a single hand, from the upper portion 2 while the surface cleaning apparatus is in use without requiring the user to deactivate or unlock any locking device. This may allow a user to easily change between cleaning modes (e.g. FIG. 3 to FIG. 9, and vice versa). Preferably, this feature is used in combination with a portable surface cleaning unit mount that will retain the portable cleaning unit in position on the upper portion when the lock is disengaged and the upper portion is in a floor cleaning position. Such a retaining member may be mechanical (e.g., inter-engaging members, one or more magnets or the like).

Referring to FIGS. 31A and 31B, another embodiment of a surface cleaning apparatus 1001 including one embodiment of an automatic unlocking system 1200 is shown. This embodiment exemplifies an electro-mechanical surface cleaning unit lock. Surface cleaning apparatus 1001 is generally similar to surface cleaning apparatus 1, and analogous features are identified using like reference characters indexed by 1000.

Referring also to FIGS. 32A and 32B, in the illustrated embodiment, the unlocking system 1200 includes a latching member 1201 that can engage a corresponding receiving member 1202, thereby locking the surface cleaning unit 1004 to the upper portion 1002 (i.e. inhibiting its removal). The system 1200 also includes an actuating mechanism 1203 that is operable to control the latching member 1201 based on the configuration of the surface cleaning apparatus.

In the illustrated embodiment, the latching member 1201 is provided in the form of a solenoid 1204 that has a body portion 1205 and a pin 1206 that can be extended and retracted along axis 1207. The receiving member 1202 is provided in the form of a flange 1208 extending from the surface cleaning unit 100, which includes a hole 1209 sized to receive the pin 1206. When the pin 1206 is inserted into the hole 1209 (FIG. 32A) the surface cleaning unit 1004 is locked to the upper portion 2. When the pin 1206 is retracted from the hole 1209 (FIG. 32B) the surface cleaning unit 1004 is unlocked. Preferably, the solenoid is configured so as to be in the locked position when de-energized. An advantage of this design is that, if the surface cleaning unit is unplugged, the lock will be in the locked position.

Optionally, the surface cleaning unit 1001 may also include any suitable type of retaining member (including the spine and channel and pin and slot described herein) to help hold the surface cleaning unit 1004 in a desired position (FIG. 31B) even though the locking mechanism has been disengaged. In the illustrated embodiment, the surface cleaning apparatus 1001 includes a retaining member in the form of mating magnets 1210 provided on the surface cleaning unit 1004 and upper portion 1002. The magnet attraction between the magnets 1210 can hold the surface cleaning unit 1004 in place when the locking mechanism is unlocked. The holding force of the magnets 1210 can be selected so that a user can overpower the holding force when attempting to remove the surface cleaning unit 1004. Providing magnetic retention in this manner may allow the surface cleaning unit 1004 to be held in place when unlocked, while still allowing the user to remove the surface cleaning unit 1004 using a single hand and/or without having to unlock mechanical devices.

In the illustrated embodiment, the system 1200 is configured to lock the surface cleaning apparatus 1004 when the upper portion 1002 is upright (FIG. 31A) and automatically unlock when the upper portion 1002 is inclined (FIG. 31B). Referring to FIG. 32A, the actuating mechanism 1203

includes a pendulum member 1211 that is pivotally mounted to the upper portion 2. When the upper portion 1002 is inclined, the pendulum member 1211 can pivot under the force of gravity to contact and engage a trigger button 1212 (FIG. 32B). The trigger button 1212 is electrically connected to solenoid 1205, and is configured such that actuating the button 1212 retracts the pin 1206 from the hole 1209, thereby unlocking surface cleaning unit 4. When the upper portion 1002 is returned to its upright position, the pendulum member 1211 may swing away from the trigger button 1212, thereby causing the pin 1206 to extend into the hole 1209, thereby locking the surface cleaning unit 1004 in position. Accordingly, if the latch 70 is released, the surface cleaning unit 4 will remain in position due to pin 1206 being engaged with hole 1209.

Referring to FIGS. 33A to 34B, another embodiment of a surface cleaning apparatus 2001 including one embodiment of an automatic unlocking system 2200 is shown. Surface cleaning apparatus 2001 is generally similar to surface cleaning apparatus 1, and analogous features are identified using like reference characters indexed by 2000. In this embodiment, the surface cleaning unit lock is mechanical,

In this embodiment, the automatic unlocking system 2200 includes a latching member 2201 provided on the upper portion 2002, and a corresponding receiving member 2202 on the surface cleaning unit 2004. An actuating mechanism 2203 is connected to the latching member 2201 to automatically engage and/or disengage the latching member 2201 based on the position of the upper portion 2002.

In the illustrated embodiment, the latching member 2201 is provided in the form of a locking arm 2213 that is pivotally coupled to the upper portion 2002, and the receiving member 2202 is provided in the form of a cavity 2214 having an engagement surface 2215. The locking arm 2213 is movable between a locked position (FIG. 34A) in which it bears against the engagement surface 2215, and an unlocked position (FIG. 34B) in which the locking arm 2213 is spaced apart from the engagement surface 2215.

The actuating mechanism 2203 is provided in the form of a linkage rod 2216 that is pivotally connected to the surface cleaning head 2003 and the locking arm 2213. As the pivot axis 2217 of the linkage rod 2216 is offset from the pivot joint connecting the upper portion 2002 to the surface cleaning head 2003, pivoting the upper portion 2002 relative to the cleaning head 2003 will cause the locking arm 2213 to pivot as shown.

If additional securement is desired, the locking arm 2213 may be provided with an optional projection 2218 that is sized to be inserted into a corresponding hole 2219 in the engagement surface 2215. This may provide additional securement in the lateral direction (as illustrated).

Referring to FIGS. 35A to 36B, another embodiment of a surface cleaning apparatus 3001 including one embodiment of an automatic unlocking system 3200 is shown. Surface cleaning apparatus 3001 is generally similar to surface cleaning apparatus 1, and analogous features are identified using like reference characters indexed by 3000.

In this embodiment, similar to the embodiment of FIGS. 31A-32B, the latching member 3201 is a solenoid 3204, having a body 3205 and a movable pin 3206. The receiving member 1202 is a flange 3208 having a hole 3209 to receive the pin 3206. The actuating mechanism 3203 includes a switch 3220 provided on the surface cleaning head 3003, and a trigger member 3221 provided on the upper portion 3002. The trigger member is positioned so that when the upper portion 3002 is moved from the upright position (FIG. 36A) to an inclined position (FIG. 36B) the trigger member

3221 moves the switch **3220** to an unlocked position causing the solenoid pin **3206** to retract, thereby unlocking the surface cleaning unit **3004**. When the upper portion **3002** is pivoted from an inclined position (FIG. 36B) to the upright position (FIG. 36A) the trigger member **3221** moves the switch to a locked position causing the solenoid pin **3206** to extend into the hole **3209** thereby locking the surface cleaning unit **3220**.

In other embodiments, any suitable type of actuating mechanism may be used (including, for example proximity switches, optical sensors, micro switches, etc.) and the relative position of the latching and receiving members can be switched.

Foot Pedal Lock Release

The following is a description of a foot pedal that may be used by itself in any surface cleaning apparatus or in any combination or sub-combination with any other feature or features disclosed herein.

In accordance with one aspect of the teachings described herein, the locking mechanism used to lock the surface cleaning unit to the upper portion may be unlocked and/or disengaged using a foot operated mechanism, including for example a foot pedal, instead of (or in addition to) the hand operated and automatic embodiments described herein.

Referring to FIG. 37, another embodiment of a surface cleaning apparatus **4001** is illustrated. The surface cleaning apparatus **4001** is generally similar to surface cleaning apparatus **1**, and analogous features are identified using like reference characters indexed by **4000**.

In this embodiment, the surface cleaning unit **4004** includes a spine **4061** that seats within a corresponding channel **4062** on the upper portion **4002** and is mounted on and at least partially supported by an upper section mount. In the illustrated example, the upper section mount is configured as a pedestal member **4300** that is pivotally coupled to the surface cleaning head **4003**. In this configuration the surface cleaning unit **4004** is directly coupled to the surface cleaning head **4003**, as opposed to be entirely supported on the lower wand portion **4102**, and can remain seated on the pedestal member **4300** when the upper wand portion **4102** is removed.

In the illustrated embodiment, both the surface cleaning unit **4004** and the lower wand portion **4102** are coupled to the pedestal member **4300** using a single locking member that can be actuated via a single actuator. In the illustrated example, the single locking member is configured as common locking mechanism **4301** (see also FIG. 39). The locking mechanism **4301** is configured to be foot-operable, and includes an actuator in the form of a foot pedal **4302** that is pivotally connected to the pedestal **4300** and pivotal about axis **4303**.

The pedal **4302** includes a contact portion **4304** that is configured to be stepped on by a user, and an engagement portion **4305** (see also FIG. 39). The contact portion **4304** and engagement portion **4305** are rigidly connected to each other on opposite sides of the pivot axis **4303**, so that downward movement of the contact portion **4304** causes a corresponding upward movement of the engagement portion **4305**, and vice versa. In the illustrated example, the contact portion **4304** can be pivoted between a raised position (FIG. 38) and a lowered or depressed position (FIG. 40). Preferably, the pedal **4302** is biased (for example using a spring) so that the contact portion **4304** is biased toward the raised position.

Referring to FIG. 39, in the illustrated embodiment the locking mechanism **4301** also includes a latching mechanism **4306** that can be actuated by the pedal **4304**. In this

configuration, the latching mechanism **4306** includes a housing **4307** that contains a slidable driving member **4308** and pivotal latch member **4309**.

The driving member **4308** is positioned within the housing **4307** and can translate axially along axis **4310** when driven by the engagement portion **4305** of the pedal **4302**. For example, when pedal **4302** is not depressed (FIG. 39) the engagement portion **4305** is spaced apart from, and positioned beneath the driving member **4308**. When the pedal **4302** is depressed (FIG. 4) the engagement portion **4305** is moved upward, into contact with the driving member **4308** and moves the driving member **4308** upwards, within the housing **4307**.

Referring to FIG. 39, when the locking mechanism **4301** is in its locked configuration, driving member **4308** is located toward the bottom of the housing **4307** and the latch member **4309** locks both the surface cleaning unit **4004** and the lower wand portion **4102** to the pedestal **4300**. In the illustrated embodiment, the latch member **4309** includes an upper latch member **4311** for locking the surface cleaning unit **4004** and a lower latch member **4312** for locking the lower wand portion **4102**. The latching member **4309** also includes connecting arm **4316** configured to engage the driving member **4308**.

The upper latch member **4311** engages an upward facing shoulder surface **4313** on a bracket **4314** extending from the surface cleaning unit **4**, and inhibits vertical movement of the bracket **4314**, thereby preventing detachment of the surface cleaning unit **4**. The lower latch member **4312** extends rearwardly, out of the housing **4307** and engages a corresponding notch **4315** in the sidewall of the lower wand portion **4102**, thereby inhibiting its vertical movement relative to the pedestal **4300** and locking it in place. In the locked configuration, the distal end of the connecting arm **4316** is received within a chamfered notch **4317** in the driving member **4308**.

To unlock both of the lower wand portion **4102** and the surface cleaning unit **4004** a user can depress the pedal **4302**. When the pedal **4302** is pivoted, the engagement portion **4305** moves the driving member **4308** upwards (FIG. 41). Due to the inclined or chamfered nature of the notch **4317**, moving the driving member **4308** urges the connecting arm **4316** out of the notch **4317** and causes the entire latching member **4309** to pivot about its pivot axis **4318** to an unlocked position (FIG. 41), as illustrated by arrow **4319**. Biasing springs **4321** provided within the housing **4307** resist both the upward movement of the driving member **4308** and the rotation of the latching member **4309**.

When the latch member **4309** pivots to the unlocked position, the upper latch **4311** is moved clear of the retaining shoulder **4313** and the lower latch **4312** is moved inwardly, and at least partially removed from notch **4315**. Simultaneously, the free end of the connection arm **4316** is urged into and retained in lower notch **4320** in the driving member **4308** by the biasing spring **4321** acting against the latching member **4309**. When the latching member **4309** is in the position illustrated in FIG. 41, the locking mechanism is in an unlocked or charged position, and either of the surface cleaning unit **4004** and the lower wand portion **4102** can be removed. Further, when the connecting arm **4316** is engaged within lower notch **4320** and biasing springs **4321** exert their biasing forces on the latching member **4309** and the driving member **4308**, the locking mechanism **4301** will remain in its unlocked position even if the pedal **4302** is released. From this unlocked or charged position, a user may remove either of the surface cleaning unit **4004** or the lower wand portion **4102** and the locking mechanism **4301** is operable to

automatically re-lock the remaining one of the surface cleaning unit **4004** or the lower wand portion **4102** to the pedestal **4300**. This allows a user to remove one portion of the surface cleaning apparatus, and automatically have the other portion re-locked so that it is not unintentionally removed. For example, a user may wish to detach the lower wand portion **4102** to perform above floor cleaning and may wish to keep the surface cleaning unit **4004** locked to the pedestal **4300** so that it does not accidentally fall off or become disconnected.

For example, referring to FIG. **42**, if the surface cleaning unit **4004** is removed by translating it vertically, a projection **4322** extending laterally from the bracket **4314** (beyond the shoulder surface **4313**) contacts the upper latch **4311** and moves it to the left as illustrated, thereby causing a slight over-rotation of the latch member **4309** (counter-clockwise as illustrated). This over-rotation causes connecting arm **4316** to pivot out of lower notch **4320** on the driving member **4308**. When the connecting arm **4316** is free from the lower notch **4320**, the biasing force of the vertical spring **4321a** urges the driving member **4308** downward. Simultaneously, the biasing force of horizontal spring **4321b** acts on the latching member **4309** and rotates it clockwise (as illustrated) until it both the driving member **4308** and latching member **4309** are returned to their original, locked positions (FIG. **43**), in which the lower latch **4312** engages the notch **4315** and locks the lower wand portion **4102** to the pedestal **4300**.

Alternatively, instead of removing the surface cleaning unit **4004**, a user may wish to remove the lower wand portion **4102**. Referring to FIG. **44**, if the locking mechanism **4301** is in the unlocked or charged position (FIG. **39**) a user may remove the lower wand portion **4102** by pulling it upward, as illustrated. Pulling the lower wand portion **4102** upward causes the lower edge **4323** of the notch **4315** to contact and urge the lower latch **4312** to the right (as illustrated) thereby pivoting the latching member **4309** in a counter-clockwise direction. As noted above, pivoting the latching member **4309** in a counter clockwise direction disengages the connecting arm **4316** from the lower notch **4320**, thereby allowing the springs **4321a** and **4321b** to drive the driving member **4308** and latching member **4309** back to their locked positions (FIG. **45**). In the locked position, the upper latch **4311** engages the shoulder surface **4313** and locks the surface cleaning apparatus **4004** to the pedestal **4300**.

If a user wishes to separate both the surface cleaning unit **4004** and the lower wand portion **4102** from the pedestal **4300**, the locking mechanism **4301** can be operated twice, in series. For example, the user may depress the pedal **4302** to unlock the mechanism **4301** and then remove the surface cleaning unit **4004**. This will re-lock the lower wand portion **4102**. A user can then depress the pedal **4302** again to unlock the mechanism **4301** and then remove the lower wand portion **4102** (or vice versa). It will be appreciated that the foot pedal may be operable to only release unit **4** and not the wand.

Internal Cyclone Bin Assembly Locking Mechanism

The following is a description of an internal locking system that may be used by itself in any surface cleaning apparatus or in any combination or sub-combination with any other feature or features disclosed herein. According to this embodiment, the cyclone bin assembly (or other portion of the surface cleaning unit) may be secured in position (e. g. to a suction motor housing) by one or more locking members positioned internally of the unit **4** and, preferably, internal of the cyclone bin assembly. The actuator may be

provided on any desired portion of portable surface cleaning unit **4** and may be provided on the cyclone bin assembly proximate or on the handle of the cyclone bin assembly.

Conventional cyclone bin locking mechanisms can include external latches or clips that a user can disengage to release the cyclone bin assembly. External latches can be aesthetically unpleasing and may be vulnerable to accidental release, for example if they are hit or caught on an obstacle or furniture. External latches are also vulnerable to damage from impact with other objects. Providing a latching mechanism within the surface cleaning unit (e.g., within the cyclone bin assembly) may help protect the mechanism, may help prevent accidental release and may help improve the appearance of the surface cleaning unit.

Referring to FIGS. **46A** and **46B**, another embodiment of a surface cleaning unit **5004** is shown in cross-section. The surface cleaning unit **5004** is generally similar to surface cleaning unit **4**, and analogous features are identified using like reference characters indexed by **5000**. The surface cleaning unit includes a locking mechanism **5400** for securing the cyclone bin assembly **5009** to the suction motor housing **5012**.

As exemplified in FIGS. **46A** and **46B**, the locking mechanism **5400** includes a first connector portion or locking member **5401** connected to the cyclone bin assembly **5009**, and a mating second connector portion or locking member **5402** provided on the suction motor housing **5012**. Preferably, the first and second connectors **5401**, **5402** are detachably connectable to each other, and can be configured in a locked position (FIG. **46A**) to hold the cyclone bin assembly **5009** on the motor housing **5012**, and an unlocked position (FIG. **46B**). The connectors may be of any configuration. For example, they may inter-engage or interlock when moved towards each other. One may be stationary and the other may be moveable or both may be moveable, such as being provided on a moveable arm.

In the illustrated embodiment, the first connector **5401** is provided in the form of a first rod **5403** connected to the vortex finder **5039** of the cyclone bin assembly **5009** that extends downwardly in the air flow path. It will be appreciated that the rod may be secured at an alternate position and still extend downwardly. A hook **5404** is provided on the distal end of the rod **5403**. The second connector **5402** includes a second rod **5405** attached to the lower wall of the pre-motor filter chamber **5031** that projects upwardly through a passage **5406** in the filters **5032**, **5033**. A second hook **5407** is provided at the distal end of rod **5405**. The second rod **5405** is pivotal about a pivot joint **5408**, and can be pivoted between a locked position (FIG. **46A**) in which the two hooks **5404** and **5407** engage each other (thereby locking the cyclone bin assembly) and an unlocked position (FIG. **46B**) in which the second hook **5407** is pivoted out of engagement with the first hook **5404**.

The second rod **5405** may be pivoted using any suitable actuator. In the illustrated example, a bin release actuator **5409** is provided on the motor housing **5012**. The actuator **5409** includes a contact portion **5410** connected to a transfer rod **5411** that is slidable relative to the housing **5012**. A biasing spring **5413** urges the transfer rod **5411** away from the second rod **5405** (to the right as illustrated). Absent input from a user, the transfer rod **5411** is biased to the right, and the free end **5414** of the transfer rod **5411** is spaced apart from the lower end **5415** of the rod **5405**. When a user presses on the contact portion **5409**, the transfer rod **5411** slides to the left, contacting the lower portion **5415** of the rod **5405** thereby pivoting the second rod **5405** and unlocking the cyclone bin assembly **5009**. A return biasing spring **5416**

can be provided to urge the second rod **5405** toward its locked position to re-engage the first hook **5404** when input on the contact member **5409** is removed. It will be appreciated that a drive motor may alternately be provided to move the rod.

Referring to FIGS. **47A** and **47B**, another embodiment of a surface cleaning unit **6004** is shown in cross-section. The surface cleaning unit **6004** is generally similar to surface cleaning unit **4**, and analogous features are identified using like reference characters indexed by **6000**. The surface cleaning unit includes a locking mechanism **6400** for securing the cyclone bin assembly **6009** to the suction motor housing **6012**.

In this illustrated embodiment, the locking mechanism **6400** includes a first connector **6401** and a mating second connector portion **6402**. As in the embodiment above, the first connector **6401** is provided on the cyclone bin assembly **6009** and the second connector **6402** is connected to the bottom wall of the pre-motor filter chamber **6031** and extends upwardly through a passage **6406** in the filters **6032**, **6033**.

In this embodiment, the first connector **6401** includes a grasping member **6420**. The grasping member **6420** includes first and second jaw members **6421** and **6422** that are pivotally connected to each other, and to respective struts **6423** and **6424**. The jaw members **6421** and **6422** are also pivotally connected to the bottom end of driving rod **6425**. The bin release actuator **6409** includes a contact member **6426** that is provided at the other end of the driving rod **6425**, and a biasing spring **6427** urges the contact member **6426** and driving rod **6425** upward.

The second connector portion **6402** includes an engagement member **6428** (a ball-like element in the embodiment illustrated) provided on the upper end of a support rod **6529**.

When cyclone bin assembly **6009** is seated on the housing **6012** and the contact member **6426** is in its raised position (FIG. **47A**) the jaw members **6421** and **6422** encase the engagement member **6428**, thereby locking the cyclone bin assembly **6009** in place. In this configuration, the first and second connectors **6401** and **6402** are provided within the air flow path between the cyclone chamber **6010** and the suction motor **6008**.

To remove the cyclone bin assembly **6009**, a user can press down on the contact member **6426**, which drives the driving rod **6425** downward and causes the jaw members **6421** and **6422** to pivot to their open or unlocked position (FIG. **47B**), thereby releasing the cyclone bin assembly **6009**.

In the illustrated embodiment, the contact member **6426** is provided on the lid **6046** of the cyclone bin assembly **6009**, and is adjacent the handle **6047**. Positioning the contact portion **6426** adjacent the handle may allow a user to activate the locking mechanism **6400** while holding the handle **6047**.

In this embodiment, the lower end of the first connector **6401** is positioned above a plane **6530** that includes the bottom surface of the cyclone bin assembly **6009**. In this configuration, when the cyclone bin assembly **6009** is removed its lower surface **6531** is generally flat. This may allow the cyclone bin assembly **6009** to be rested on a flat surface, such as a counter top and/or a floor. Preferable, if needed, the sidewall of the cyclone bin assembly extends sufficiently downwardly so that the bottom edge is below the locking member provided on the cyclone bin assembly.

Referring to FIGS. **48A** and **48B**, another embodiment of a surface cleaning unit **6004** is shown in cross-section. The surface cleaning unit **7004** is generally similar to surface

cleaning unit **4**, and analogous features are identified using like reference characters indexed by **7000**. The surface cleaning unit includes a locking mechanism **7400** for securing the cyclone bin assembly **7009** to the suction motor housing **7012**.

In this embodiment, the locking mechanism **7400** includes a first connector **7401** positioned in the cyclone bin assembly **7009**, and a second connector **7402** provided in the motor housing **7012**. The first connector **7401** is provided in the form a pair of rods **7440a** and **7440b** that are provided in the floor of the cyclone bin assembly **7009**. The rods **7440a** and **7440b** can slide horizontally between a retracted position (FIG. **48B**), in which the rods **7440a** and **7440b** are nested within the cyclone bin assembly, and an extended position (FIG. **48A**), in which the ends **7440a** and **7440b** of the rods **7440a** and **7440b** extend beyond the lower side edge **7442** of the cyclone bin assembly **7009**. Biasing springs **7443a** and **7443b** are positioned to urge the respective rods **7440a** and **7440b** toward the extended position. Therefore, the sidewall of the cyclone bin may be extended downwardly to provide a flat surface which may be rested on a floor and to protect the locking member.

Connector **7402** on the housing **7012** is provided in the form of apertures **7444a,b** that are configured to receive respective rods **7440a,b**.

The bin release actuator **7409** includes a contact portion **7426** attached to the top of a connecting rod **7445**. A biasing spring **7427** biases the contact portion **7426** and connecting rod **7445** upward.

The bottom end of the connecting rod **7445** has an angled tip **7446**. The tip **7446** is configured to abut inclined bearing surfaces **7447a,b** on respective engagement blocks **7448a,b** provided on the rods **7440a,b**. When the contact portion **7426** is depressed by a user, the connecting rod **7445** is driven downward and tip **7446** pushes against the bearing surfaces **7447a,b**, the downward motion of connecting rod **7445** is translated into lateral, contraction motion of the rods **7440a,b**, thereby retracting the rods **7440a,b** and withdrawing the ends **7441a,b** from their respective apertures **7444a,b** and unlocking the cyclone bin assembly **7009**.

To reattach the cyclone bin assembly **7009**, the actuator **7409** can be triggered, retracting the pins **7440a,b**, the cyclone bin assembly **7009** can be seated on the motor housing **7012** and the actuator **7409** can be released. Cyclone Chamber

The following is a description of a cyclone chamber that may be used by itself in any surface cleaning apparatus or in any combination or sub-combination with any other feature or features disclosed herein. According to this embodiment, the dirt chamber and/or cyclone chamber door may be secured in a closed position by a lock that is internal of the cyclone bin assembly and may be internal of the cyclone chamber. The actuator may be provided on any desired portion of cyclone bin assembly and may be provided on the cyclone bin assembly proximate to or on the handle of the cyclone bin assembly.

Referring to FIGS. **49-53** in the illustrated embodiment the cyclone chamber **10** extends along a cyclone axis **38** and includes a first end wall **39**, a second end wall **40** axially spaced apart from the first end wall **39** and a generally cylindrical sidewall **41** extending between the first and second end walls **39**, **40**. Optionally, some or all of the cyclone walls can coincide with portions of the dirt collection chamber walls, suction motor housing walls and/or may form portions of the outer surface of the surface cleaning unit. Alternatively, in some examples some or all of the

cyclone walls can be distinct from other portions of the surface cleaning unit. In the illustrated embodiment, the cyclone chamber **10** is arranged in a generally vertical, inverted cyclone configuration. Alternatively, the cyclone chamber can be provided in another configuration, including, having at least one or both of the air inlet and air outlet positioned toward the top of the cyclone chamber, or as a horizontal or inclined cyclone.

In the illustrated embodiment, the cyclone chamber **10** includes a cyclone air inlet **42** and a cyclone air outlet **43**. The cyclone chamber **10** preferably also includes at least one dirt outlet **44**, through which dirt and debris that is separated from the air flow can exit the cyclone chamber **10**. While it is preferred that most or all of the dirt exit the cyclone chamber via the dirt outlet, some dirt may settle on the bottom end wall **40** of the cyclone chamber **10** and/or may be carried with the air exiting the cyclone chamber via the air outlet **43**.

Preferably the cyclone air inlet **42** is located toward one end of the cyclone chamber **10** (the lower end in the example illustrated) and may be positioned adjacent the corresponding cyclone chamber end wall **40**. Alternatively, the cyclone air inlet **42** may be provided at another location within the cyclone chamber **10**.

Referring to FIG. **49**, in the illustrated embodiment the air inlet **42** includes an upstream or inlet end **45**, which may be coupled to the hose **7** or other suitable conduit, and a downstream end **46** (FIG. **50**) that is spaced apart from the upstream end **45**. In the illustrated configuration, the cyclone bin assembly **9** can be removed from the surface cleaning unit **4**, for example for cleaning or emptying, while the hose **7** remains with the upper portion **2**. This may allow a user to remove the cyclone bin assembly **9** without having to detach or decouple the hose **7**. Alternatively, the downstream end of the hose **7** may be coupled to the cyclone bin assembly **9** such that the downstream end of the hose travels with the cyclone bin assembly when it is removed.

The air inlet **42** defines an inlet axis **47** and has an inlet diameter **48** (FIG. **50**). The cross-sectional area of the air inlet **42** taken in a plane orthogonal to the inlet axis **47** can be referred to as the cross-sectional area or flow area of the air inlet **42**. Preferably, the air inlet **42** is positioned so that air flowing out of the downstream end is travelling generally tangentially relative to, and preferably adjacent, the sidewall **41** of the cyclone chamber **10**.

The perimeter of the air inlet **42** defines a cross-sectional shape of the air inlet. The cross-sectional shape of the air inlet can be any suitable shape. In the illustrated example the air inlet has a generally round or circular cross-sectional shape with a diameter **48**. Optionally, the diameter **48** may be between about 0.25 inches and about 5 inches or more, preferably between about 1 inch and about 5 inches, more preferably is between about 0.75 and 2 inches or between about 1.5 inches and about 3 inches, and most preferably is about 2 to 2.5 inches or between about 1 to 1.5 inches. Alternatively, instead of being circular, the cross-sectional shape of the air inlet may be another shape, including, for example, oval, square and rectangle.

Air can exit the cyclone chamber **10** via the air outlet **43**. Optionally, the cyclone air outlet may be positioned in one of the cyclone chamber end walls and, in the example illustrated, is positioned in the same end as the air inlet **42** and air inlet **42** may be positioned adjacent or at the end wall **40**. In the illustrated example, the cyclone air outlet **43** comprises a vortex finder **49**. In the example illustrated, the longitudinal cyclone axis **38** is aligned with the orientation of the vortex finder. Alternatively, the cyclone air outlet **43**

may be spaced apart from the cyclone air inlet **42**, and may be located toward the other end of the cyclone chamber **10**.

In the illustrated embodiment the air outlet **43** is generally circular in cross-sectional shape and defines an air outlet diameter **51** (FIG. **50**). Optionally, the cross-sectional or flow area of the cyclone air outlet **43** may be between about 50% and about 150% and between about 60%-90% and about 70%-80% of the cross-sectional area of the cyclone air inlet **42**, and preferable is generally equal to the cyclone air inlet area. In this configuration, the air outlet diameter **51** may be about the same as the air inlet diameter **48**.

When combined with any other embodiment, the cyclone bin assembly **9** may be of any particular design and may use any number of cyclone chambers and dirt collection chambers. The following is a description of exemplified features of a cyclone bin assembly any of which may be used either individually or in any combination or sub-combination with any other feature disclosed herein.

The following is a description of a screen that may be used by itself in any surface cleaning apparatus or in any combination or sub-combination with any other feature or features disclosed herein.

Optionally, a screen or other type of filter member may be provided on the cyclone air outlet **43** to help prevent fluff, lint and other debris from exiting via the air outlet. Referring to FIG. **50**, in the illustrated example a screen **50** is positioned at the air outlet **43** and connected to the vortex finder **49**. In FIG. **50** the screen is illustrated with mesh in place, however for clarity the mesh has been omitted from the other Figures. The screen **50** is generally cylindrical in the illustrated embodiment, but may be of any suitable shape in other embodiments. Optionally, the screen **50** can be removable from the vortex finder **49**.

Optionally, the screen **50** may be sized to have a cross-section area that is larger than, smaller than or generally equal to the air outlet **43** cross-sectional area. Referring to FIG. **50**, in the illustrated example, the diameter **52** of the screen **50** is less than the diameter **51** of the vortex finder **49** conduit providing the cyclone air outlet **43**. In this configuration, the radial surface **53** of the screen **50** is radially offset inwardly from the surface **54** of the vortex finder **49** by an offset distance **55**. Providing the offset gap **55** between the surfaces **53**, **54** of the screen **50** and vortex finder **49** may help provide a relatively calmer region (i.e. a region of reduced air flow turbulence and/or laminar air flow) within the cyclone chamber **10**. It may also assist the air that has been treated in the cyclone chamber to travel towards the vortex finder while mixing less with the air entering the cyclone chamber via the air inlet and thereby reduce the likelihood of dirt bypassing treatment in the cyclone chamber and travelling directly to the air outlet. Providing a relatively calmer air flow region adjacent the surface **53** of the screen **50** may help enable air to more easily flow through the screen **50** and into the vortex finder **49**, which may help reduce backpressure in the air flow path. Reducing back pressure may help improve the efficiency of the cyclone chamber and/or may help reduce power requirements for generating and/or maintaining a desired level of suction.

In the illustrated embodiment the screen **50** is of generally constant diameter. Alternatively, the diameter of the screen **50** may vary along its length. For example, the screen may be generally tapered and may narrow toward its upper end (i.e. the end that is spaced apart from the vortex finder **49**). The cross sectional area of the inner end of the screen may

be 60-90% the cross sectional area of the air inlet and preferably is 70-80% the cross sectional area of the air inlet.
Dirt Outlet

The following is a description of a cyclone dirt outlet that may be used by itself in any surface cleaning apparatus or in any combination or sub-combination with any other feature or features disclosed herein.

Cyclone chamber **10** may be in communication with a dirt collection chamber by any suitable means. Preferably, as exemplified, the dirt collection chamber **11** is exterior to cyclone chamber **10**, and preferably has a sidewall **56** that at least partially or completely laterally surrounds the cyclone chamber **10**. At least partially nesting the cyclone chamber **10** within the dirt collection chamber **11** may help reduce the overall size of the cyclone bin assembly. The cyclone chamber sidewall **41** may be coincident with the sidewall **56** at one or more (e.g., three locations) around its perimeter.

In the illustrated embodiment, the dirt outlet **44** is in communication with the cyclone chamber **10** and the dirt collection chamber **11**. Optionally, the dirt outlet **44** can be axially and/or angularly spaced from the cyclone air inlet. Preferably, the cyclone dirt outlet **44** is positioned toward the opposite end of the cyclone chamber **10** from the cyclone air inlet **42**. The cyclone dirt outlet **44** may be any type of opening and may be in communication with the dirt collection chamber to allow dirt and debris to exit the cyclone chamber **10** and enter the dirt collection chamber **11**.

In the illustrated example, the cyclone dirt outlet **44** is in the form of a slot bounded by the cyclone side wall **41** and the upper cyclone end wall **39**, and is located toward the upper end of the cyclone chamber **10**. Alternatively, in other embodiments, the dirt outlet may be of any other suitable configuration, and may be provided at another location in the cyclone chamber, including, for example as an annular gap between the sidewall and an end wall of the cyclone chamber or an arrestor plate or other suitable member.

The dirt collection chamber **11** may be of any suitable configuration. Referring to FIG. **50**, in the illustrated example, the dirt collection chamber **11** includes a first end wall **57**, a second end wall **58** and the sidewall **56** extending therebetween.

To help facilitate emptying the dirt collection chamber **11**, at least one of or both of the end walls **57**, **58** may be openable. Similarly, one or both of the cyclone chamber end walls **39** and **40** may be openable to allow a user to empty debris from the cyclone chamber. Referring to FIG. **50**, in the illustrated example, the upper dirt chamber end wall **57** is integral with the upper cyclone end wall **39** and the lower dirt collection chamber end wall **58** is integral with, and openable with, the lower cyclone chamber end wall **40** and both form part of the openable bottom door **59**. The door **59** is moveable between a closed position (FIG. **51**) and an open position (FIG. **52**). When the door **59** is open, both the cyclone chamber **10** and the dirt collection chamber **11** can be emptied concurrently. Alternatively, the end walls of the dirt collection chamber **11** and the cyclone chamber **10** need not be integral with each other, and the dirt collection chamber **11** may be openable independently of the cyclone chamber **10**.

Preferably, the openable door **59** can be secured in its closed position until opened by a user. The door **59** may be held closed using any suitable latch or fastening mechanism.

Internal Door Locking System

The following is a description of an internal door locking system that may be used by itself in any surface cleaning

apparatus or in any combination or sub-combination with any other feature or features disclosed herein.

As noted above with relation to the cyclone bin assembly **9** locking mechanism, providing an internal locking or latching mechanism may be preferable to an external locking mechanism. Accordingly, the cyclone bin assembly **9** can be provided with an internal door latching mechanism for securing the door **59** in its closed position. The latching mechanism may comprise a member that is internal of the air flow path and may latch onto the vortex finder or other portion of the air flow path.

Referring to FIG. **51**, in the illustrated embodiment the cyclone bin assembly **9** includes a door latch mechanism **75**. The latch mechanism **75** includes a latch member **76** (FIG. **53**). The latch member **76** is connected to the lid **546** of the cyclone bin assembly **9** by pivot joint **77**, and can pivot about axis **78** (FIG. **51**). Alternatively, the latch member **76** may be connected to another portion of the cyclone bin assembly **9**, including, for example the upper wall **39**.

The latch member **76** includes a first arm **79** that extends generally horizontally, and a second arm **80** that extends generally vertically in the illustrated example. The first arm **79** includes a contact member **81** that is configured to be pressed by a user. A biasing spring **82** is provided between the first arm **79** and the upper wall **39**, and biases the first arm **79** upwards.

The second arm **80** includes an engagement member **83** in the form of a projection that can engage and retain a retaining shoulder **84** on the upper end of the screen **50**. While illustrated as part of the screen **50**, the retaining shoulder **84** can be provided on any suitable member, including for example an insert or extension member provided at the end of the screen **50**. The door **59** is attached to the bin assembly **9** by hinges **85** and can pivot to its open position (FIG. **52**).

When the latch member **76** is in the position illustrated, the projection **83** engages the retaining shoulder **84** and the door **59** is held in a closed position. When the contact member **87** is depressed by a user, the second arm **80** pivots away from the retaining shoulder **84** (counter clockwise as illustrated) and the projection **83** is spaced apart from the shoulder **84**. When the projection **83** is spaced from the shoulder **84**, the door **59** is free to open.

Preferably, the projection **83** is angled so that when the door **59** is closed, the shoulder **84** can urge the projection **83** slightly to the right, and then it is automatically returned to the left via the biasing spring **82** to allow the door **59** to be latched without requiring a user to depress the contact portion **87**.

Preferably, as illustrated, the contact portion **87** is positioned adjacent the handle **547** and more preferably is located beneath the hand grip portion **548**. In this position a user may be able to trigger the latching mechanism **75** while holding the hand grip **548** with a single hand.

It will be appreciated that the actuator may be provided at an alternate location and may be used to secure an openable lid in a closed position. For example, the cyclone may be an inverted or uniflow cyclone and the vortex finder may be part of an openable lid.

Bendable Air Flow Wand

In accordance with one aspect of the teachings described herein, which may be used by itself in any surface cleaning apparatus or in any combination or sub-combination with any other feature or features disclosed herein, the upper portion **2** may be configured as an air flow conduit and may be bendable to accommodate different use configurations.

41

Referring to FIG. 2, a cord wrap **107** is provided on the upper portion **2** to hold the electrical cord when the vacuum is not in use. The cord wrap **107** includes upper and lower cord wrap members **108, 109**, around which the cord can be wound, that are spaced apart from each other. Preferably, the cord wrap **107** is configured so that both the upper and lower cord wrap members **108, 109** are mounted to one of the upper and lower wand portions **101, 102** and are not separated by the hinge **103**. This may reduce the likelihood that the cord will interfere with the operation of the hinge **103**, and may help maintain a fixed spacing between the upper and lower cord wraps **108, 109** when the upper portion **2** is reconfigured. In the illustrated embodiment, the cord wrap **107** is provided on the lower wand portion **102**, between the surface cleaning head **3** and the hinge **103**. Alternatively, the cord wrap members **108, 109** may be provided on the upper wand portion **101**, or at any other suitable location on the surface cleaning apparatus.

In the illustrated example, the upper wand portion **101** and lower wand portion **102** are mechanically and fluidly connected by the hinge member **103**. Bending the wand **100**, via the hinge **103**, may help position the lower wand portion to better fit underneath furniture and other obstacles covering the surface that is being cleaned. The bent configuration may also help lower the center of gravity of the surface cleaning apparatus **1**, relative to the straight configuration of the upper portion.

Hinge **103** pivotally connects upper and lower portions of the wand together. It will be appreciated that the upper and lower portions may be moveably connected together other than by a pivot joint. Further, it will be appreciated that various types of pivot joints may be used and that the upper and lower portions may be in air flow communication with each other directly or, as exemplified in FIG. **54**, they may be connected in air flow communication by a hose or the like that extends between the upper and lower portions.

Referring to FIG. **54**, in the illustrated example, the hinge member **103** includes an upper yolk member **110** that is pivotally connected to a lower yolk member **111**, such that the upper yolk member **110** can pivot about hinge axis **112**. The yolk members **110, 111** provide a structural, mechanical connection between the upper and lower wand portions **101, 102**. The yolk members **111, 112** may be formed from any suitable material, including, for example, plastic and metal.

Optionally, to provide air flow communication between the upper and lower wand portions **101, 102**, the hinge **103** may include an internal fluid passage. Referring to FIG. **54**, in the illustrated example the hinge **103** includes an internal fluid passage in the form of a flexible hose member **113** that is positioned within the yolk members **110, 111** and connects the downstream end **114** of the lower wand portion **102** to the upstream end **115** of the upper wand portion **101**. Optionally, the hose **113** may be extensible and/or elastic. Preferably, the hose **113** member may be formed from the same material, and have generally the same properties as hose **7**. Optionally, instead of being positioned within the yolk members **110, 111**, the fluid passage member may be positioned outside the yolk members **110, 111**.

Preferably, the hose **113** has an internal diameter (e.g. a flow area) that is generally the same as the diameter of the flow areas of the upper and lower wand portions **101, 102** so that the hose **113** does not narrow or otherwise constrict the air flow path, in either the straight or bent configurations.

Alternatively, referring to FIG. **59**, instead of using a hose **113**, the hinge **103** may include any other suitable type of bendable or movable air flow conduit that can maintain airflow between the upper and lower wand portions **101, 102**

42

in both a straight and bent configuration. For example, the hinge may include a non-extensible tube **116** instead of the hose section, or a rotational air flow joint may be used.

The hinge **103** is moveable between a straight position (FIGS. **9** and **57**) and one or more bent positions (FIGS. **10** and **58**). When the hinge **103** is in a first position, e.g. the straight position, the upper and lower wand portions **101, 102** are generally aligned with each other, e.g., they each have a longitudinal axis and the axis are generally parallel to each other and to the upper axis **18**. While illustrated as also being generally co-axial with each other, in other embodiments the upper and lower wand portions may be offset from each other, and need not be co-axial.

Referring to FIG. **57**, the hinge is preferably retained in this first position by a biasing or locking member **117** so that the upper wand portion **101** preferably remains at a fixed angular position with lower wand portion **102** when the lock is engaged so that forward and rearward movements applied to the grip of the handle **17** can be translated to the second wand portion **102** and to the surface cleaning head **3** connected thereto.

In use, the hinge **103** can be unlocked, or released from the first position and upper wand portion **101** may be moved into one or more second or bent positions, wherein the handle **17** is preferably rotated forwardly. Optionally, the lock may remain in the unlocked position such that upper wand portion may freely rotate with respect to the lower wand portion while it is used to move the surface cleaning head.

As exemplified in FIGS. **60** and **61** the handle **17** preferably includes an actuator **118** for releasing or unlocking the releasable hinge **103**. For example, the actuator **118** can include a button or hinge release **119** that can be activated by a user during use of vacuum cleaner. It will be appreciated that the actuator **118** may be of any type and may be located at any location and is preferably provided on the handle **17** or upper wand portion **101** and is preferably adjacent or on the hand grip.

When a user depresses the hinge release **119**, the retaining or locking member **117** used to secure the hinge **103** in the first position is disengaged, allowing the hinge to rotate or pivot. As the hinge rotates, the first wand portion **101** can be moved into a plurality of angular positions relative to the second wand portion **102**. Optionally, the hinge **103** may rotate between, and lock into, one of a given number of set or indexed angular positions. Alternatively, the rotation of the hinge **103** may be continuously variable, after being initially unlocked, allowing for the first wand portion to be moved into an indefinite number of angular positions relative to the second wand portion (e.g., freely rotatable).

In the illustrated example, the hinge **103** can be unlocked and the wand can be bent without materially interfering with the air flow through the upper portion **2**, and without disconnecting the upper wand portion **101**, lower wand portion **102**, hose **7**, handle **17** or hose **113**.

Referring to FIG. **61** the hinge release button **119** on the handle **17** is connected to an internal slide member **120** that is movable within the handle **17** housing. The lower end of the slide member **120** abuts a terminal block **121** which is provided on the downstream end **122** of the upper wand portion **101** and is connected to the upper end **123** of a connecting rod **124** on the exterior of the upper wand portion **101**. The slide member **120** abuts, but is not coupled to the terminal block **121** which facilitates separation of the handle **17** from the upper wand portion **101** (for example as described herein).

Referring to FIG. 62, the terminal block 121 can slide relative to the upper wand portion 101, thereby converting depression of the hinge release button 119 to axial translation of the connecting rod 124. The connecting rod 124 extends down the outside of the upper wand section 101, between the handle 17 and the hinge 103 within a rod housing 125. The rod housing may also be configured to accommodate one or more wires 126 or other electrical conducting members. Alternatively, the actuating rod 124 may be located in the interior of the upper wand portion, within the air flow path. Accordingly, the conduit that houses the driving or linking member of the lock system may also house electrical wiring. This is particularly useful if the hose is an electrified hose and the inlet end of the wand is electrified.

In the illustrated embodiment, the lower end 127 of the connecting rod 124 acts on the upper end 128 of a corresponding connecting rod 128 provided on the hinge 103. The hinge connecting rod 129 is coupled to a collar member 130 that is slidably coupled to the upper end of the hinge 103. The collar member 130 is configured to slide axially relative to the upper conduit portion 131 (FIG. 57) of the hinge 103 between a locked position (FIG. 7) and an unlocked position (FIG. 58).

Referring to FIG. 57, in the illustrated embodiment, the collar member 130 includes a pair of arms 132 extending generally downwardly, one arm 132 on each side of the hinge 103. Each arm 132 includes an upper end 133 coupled to the collar and a lower end 134 having a locking portion 135 (see also FIG. 54). Each locking portion 135 is configured to slide within a corresponding channel 136 formed between the upper and lower yolk members 110, 111 (shown in dashed lines in FIGS. 57 and 58) to allow the hinge 103 to pivot, and to be held within a retaining notch 137 (located toward one end of the channel 136), to lock the hinge 103 in its straight configuration.

Referring to FIG. 57, when the hinge 103 is locked, each locking portion 135 is nested within its respective retaining notch 137 and interference between the locking portion 135 and a shoulder portion 138 (see also FIG. 58) of the retaining notch 137 prevents rotation of the hinge 103. To disengage the locking mechanism, a user can press the hinge release button 119 which will drive the connecting rods 124, 129 downward thereby urging the collar member 130 downward (as illustrated) to free each locking portion 135 from its retaining notch 137 and position the locking portions 135 within the channel 136. In this position, the upper yolk member 110 can rotate forward relative to the lower yolk member 111. In the illustrated embodiment the locking portions 135 can slide freely within the channel 136, allowing generally free rotation of the hinge 103. Alternatively, each channel may include one or more additional retaining notches to allow the hinge to be locked in one or more rotational positions.

Optionally, the collar member 130 can be biased towards its upper or locked position. Any suitable biasing member may be used to urge the collar member toward its locked position. Referring to FIG. 57, in the illustrated example, the hinge locking mechanism includes springs 139 mounted on the upper yolk member 110 and extending between the upper yolk member 110 and a flange 140 on the arms 132 of the collar member 130. The springs 139 are positioned to exert generally axial biasing force on the arms 132, which urges the arms and collar member 130 upward. In this configuration, when the hinge 103 is rotated so that the locking portions 135 are aligned with their respective retaining notches 137 the biasing force of the springs 139 will

cause the locking portions 135 to move upward, into the retaining notches 137, thereby automatically locking the hinge 103 in the straight position. The springs 139 can be selected so that the biasing force exerted by the springs 139 is sufficient to automatically engage the hinge locking mechanism, but can be overcome by a user depressing the hinge release button 119 to release the hinge 103.

Alternatively, any other type of locking mechanism, and/or suitable release actuator may be used. Further, while illustrated as allowing the upper wand member to pivot forward relative to the lower wand member, the hinge may be configured to allow the upper wand member to also pivot backwards relative to the lower wand member.

In the illustrated example, the rod housing 125 is positioned on the outer surface of the upper wand portion 101, outside the air flow path. This may help keep the air flow path free of obstructions and may help prevent the actuator from being soiled or damaged by dirt or debris in the air flow. Alternatively, some or all of the hinge release actuator mechanisms including rod 124 and housing 125 may be positioned within the air flow path.

Optionally, the upper yolk member 110 can include removable covers 141 (FIG. 54) that can be positioned to cover one or more of the springs 139, locking members 135 and other portions of the locking mechanism. Similarly, the rod housing 125 can include a removable cover 142 to protect the rod 124 and wires 126. Preferably the covers 141, 142 are removable to allow a user to access the covered components. Alternatively, the covers 141, 142 need not be removable.

Alternatively, instead of providing a hose or other conduit member that permits air flow through the hinge, the upper portion can be configured such that the upper wand portion is replaced with a length of hose that extends between the handle and the lower wand portion 102. In such a configuration, a structural member can be provided to mechanically connect the lower wand portion 102 to the handle 17, and may be pivotally connected to the lower wand member using a hinge. In this configuration, the hinge need not include a separate air flow conduit as the hose extending from the handle 17 may be directly coupled to the lower wand portion.

Referring to FIGS. 63 and 64, another embodiment of a surface cleaning apparatus 8001 is provided. In this embodiment, the upper wand portion 101 is replaced with a hose 8143 that is seated within a structural member such as structural channel member 8144. Surface cleaning apparatus 8001 is generally similar to surface cleaning apparatus 1, and like elements are identified using like reference characters indexed by 8000.

In this embodiment, the channel member 8144 may be a generally U-shaped conduit that extends between the handle 8017 and the hinge 8103. The hinge 8103 can be generally similar to hinge 103, and a similar locking mechanism and actuator can be used to trigger the hinge 8103 by running the connecting rods, etc. down the sides, or optionally within the channel member 8144. In this configuration, the channel member 8144 may carry all the mechanical load between the handle 8017 and the hinge 8103.

The hose 8143 can be the same as hose 8007, or alternatively may be different. Optionally, the upstream end of the hose 8143 can be detachably connected to the lower wand portion 8102, and can be used for above floor cleaning when detached (either directly or connected to an auxiliary cleaning tool—see FIG. 63).

In a further alternate embodiment, the lower wand may also be replaced with a structural member such as structural

channel member **8144** and a single hose may extend along the length of both the upper and lower structural members. The structural members provide the mechanical support for the handle to be drivably connected to the surface cleaning head and the hose may be positioned therebetween. For example, the structural members may be a pair of opposed rods that are cross braced as needed. The upstream end of the hose may be removably connected for use in an above floor cleaning mode.

Connectors in Upper Portion

The following is a description of a connector that may be used by itself in any surface cleaning apparatus or in any combination or sub-combination with any other feature or features disclosed herein.

In accordance with this aspect, one or more sections of the surface cleaning apparatus may be detachable and/or reconfigurable. For example, at least one of the upper wand portion **101**, lower wand portion **102**, handle **17**, surface cleaning head **3** and hinge **103** may be detachable from each other (as shown herein). This may be accomplished by providing detachable couplings or connectors **146** between sections of the upper portion (see FIG. **5**). Providing detachable connectors **146** may allow the upper portion to be reconfigured and may facilitate or enable a plurality of different operating modes or configurations. Preferably, the connectors **146** include at least one releasable latch **147** (see FIGS. **2** and **5**) or retaining member that can be used to secure the connectors in a latched position until the latch is released or triggered by a user. Optionally, the latches **147** can be identical and can be biased toward their locked or engaged positions.

Preferably, as discussed above, at least some of the connectors **146** between the sections of the vacuum cleaner can be interchangeable and/or interconnectable with each other (e.g., the downstream end of one is connectable to the upstream end of any of the disassemble parts) to allow one portion of the vacuum cleaner (for example the upstream end of the handle **17**) to be operably connected to multiple other portions of the vacuum cleaner (for example the upper wand portion **101**, the surface cleaning head **3** and one or more accessory tools). Optionally, the connectors **146** can provide mechanical, air flow and/or electrical connections between the portions of the vacuum cleaner.

Optionally, the connectors **146** can be two-part connectors that include mating first and second portions **148** and **149** (see for example FIGS. **55A**, **55B** and **56**). Preferably, the connectors **146** are configured so that the first portion **148** of any one connector **146** can be coupled to the second portion **149** of any connector **146**, thereby providing interconnectivity between the connectors. In the illustrated example, the connectors **146** between i) the handle and the upper wand portion, ii) the upper wand portion and the hinge, iii) the lower wand portion and the surface cleaning head are interconnectable with each other (FIG. **5**).

Optionally, referring to FIG. **65**, the hose cuff connector **146** between the upstream end of the hose **7** and the handle **17** may also be compatible with some or all of the other connectors **146** on the upper portion **2**, so that the upstream end of the hose **7** can be directly connected to the downstream end of the wand portion **100**, the surface cleaning head **3** and/or any other accessory or auxiliary tool that may be configured to connect to the handle **17** and/or the wand portion **100**. Alternatively, the connector between the hose and the handle need not be compatible with the other connectors on the surface cleaning apparatus.

Referring to FIG. **54**, one example of a connector **146** suitable for connecting portions of the upper portion **2** is

illustrated at the interface between the upper wand portion **101** and the hinge **103**. While this coupling is explained in detail, it is understood that the connections **146** between other portions of the vacuum cleaner may optionally be the same as the coupling between the upper wand portion **101** and the hinge **103** to provide the interchangeability and reconfiguration options described herein. In the illustrated embodiment, a connector **146** allows the upper wand portion **101** to be detachably connected to the hinge **103**, and to provide air flow, electrical connectivity and structural connections therebetween. In the illustrated example, separating the upper wand portion **101** from the upper yolk **110** severs the air flow path and the electrical connection between the surface cleaning head **3** and the surface cleaning unit **4**.

In the illustrated embodiment, the connector **146** is an assembly of features that includes a first conduit portion **150** (FIG. **55B**) that includes a nesting portion **151** that is sized to be received within a corresponding second conduit portion **152**. In the illustrated example, both conduit portions cooperate to form part of the air flow path. Optionally, the nesting portion **151** can be sized to be snugly received within the second conduit **152** and/or provided with a gasket or other suitable sealing member so that the connection is generally air tight. Providing an air tight connection may help prevent air from being drawn into the air flow path at the connector.

Preferably, at least one retaining member is provided to secure the first conduit portion to the second conduit portion. The retaining member can be configured to resist the expected axial loading that can be exerted on the connection during use of the vacuum cleaner. In the illustrated embodiment, the retaining member includes a releasable latch member **147** that, when engaged, retains the nesting portion **151** within the second conduit portion **152**. To separate the upper wand portion **101** from the hinge **103** a user can release the latch **147**. Preferably, the latch **147** is biased toward its closed or engaged portion to help prevent inadvertent detachment of the upper wand from the hinge.

In addition to the mechanical retaining member, the connector can also optionally include electrical connections and/or mechanical connections to facilitate the operation of actuators and other machine components as well as the transfer of power or control signals. Optionally, the connector **146** can include any suitable electrical coupling(s). Preferably, the electrical coupling is configured so that it is automatically engaged when the conduit portions **151**, **152** are connected to each other, and automatically disengaged when the conduit portions **151**, **152** are separated from each other, without requiring separate actuation. Alternatively, the electrical coupling can be actuated separately from the air flow/structural connection.

In the illustrated embodiment, the electrical coupling includes an electrical socket **153** (FIG. **55B**) on the upper wand portion **101** and mating electrical prongs **154** on the hinge **103** (FIG. **55B**). When the connector **146** is separated (FIG. **55B**), male electrical connectors (e.g., the electrical prongs **154**) are exposed, and when the conduit portions are connected, the prongs **154** are received within the corresponding female electrical connector, such as electrical socket **135** (FIG. **55A**). It is preferred that the upstream end is provided with the female connector.

Preferably, at least some of the connectors **146** are configured to include portions of actuators and other components of the surface cleaning apparatus to help preserve functionality of the surface cleaning apparatus when configured in its different cleaning configurations. For example, the upstream end of the handle **17** can include a portion of

the hinge release mechanism that is configured to engage with the connecting rod **129** and collar **130** on the upper yolk member **110**. In this configuration, the handle **17** may be connected directly to the hinge **103** while preserving the capability of the hinge release button **119** to unlock the hinge **103**.

In the illustrated embodiment, the upper wand member **101** may be and/or remain electrified or energized when being attached or detached from the hinge **103**. Providing the enclosed, female socket **153** on the energized upper wand portion **103** and the exposed, male prongs **154** on the hinge member **103** (and/or any other apparatus having a compatible coupling) may help reduce the risk of a user contacting exposed, energized connectors and may help reduce the risk of electric shock. Alternatively, the electrical coupling can be configured to have prongs on the energized upper wand portion, and a corresponding socket on the hinge. Preferably, if such a configuration is used the prongs may be provided with a suitable interlock or lockout mechanism to cover and/or de-energize the prongs when the upper wand member is detached from the hinge, which may help reduce the risk of electrical shock.

While in the illustrated embodiment all of the connections are shown as being interchangeable, alternatively, only some of the connections may be interchangeable with each other. This may limit the possible configurations of the vacuum cleaner to a group of predetermined configurations.

Hose

Referring to FIG. **1**, the hose **7** may be any suitable hose that can provide fluid communication between the handle **17** and the surface cleaning unit **4**. The hose **7** may be of any suitable diameter, including, for example between about 0.5 inches and 3 inches, and may be greater than 3 inches in some configurations (for example if the surface cleaning apparatus is configured as an industrial or shop-type vacuum).

The hose may be a fixed-length hose. If the hose is of fixed length, its length can be selected so that it extends from the handle to the surface cleaning unit when the surface cleaning unit is mounted on the upper portion without being so long as to interfere with use of the vacuum.

Alternatively, the hose may be extensible and may be extendable from a contracted length to an extended length. If the hose is extensible, it may be sized so that it can generally extend between the handle and the surface cleaning unit in its contracted length, and can then be extended to the longer, extended length when the surface cleaning unit is separated from the upper portion. Optionally, the hose **7** can be configured so that the ratio of contracted length to extended length is between about 1:3 and about 1:10 or more, and may be about 1:7.

Optionally, the hose **7** can be resiliently extensible and can be biased to its contracted length. This may help keep the hose **7** in its contracted length when the surface cleaning unit **4** is mounted on the upper portion **2**, and may reduce the likelihood that the hose **7** will drag on the floor or otherwise interfere with operation of the vacuum.

Optionally, one or both ends of the hose **7** can be detachably connected to the air flow path through the vacuum cleaner, using any suitable detachable connector, including those described herein. Providing detachable connections may allow a user to detach one or both ends of the hose for maintenance, to clear blockages and/or for inspection. It may also allow the hose to be connected to different cleaning tools or portions of the surface cleaning apparatus, and may allow different hoses to be useable interchangeably with the vacuum cleaner.

Optionally, one or both ends of the hose **7** can be movably and/or rotatably coupled to other portions of the vacuum cleaner. Providing rotatable connections between the hose and the other portions of the vacuum cleaner may enable portions of the vacuum, such as the handle portion, to be manipulated into different positions (for example when used for above floor cleaning) without twisting or otherwise damaging the hose.

Referring to FIG. **65**, in the illustrated embodiment, the upstream or inlet end of the hose **7** is coupled to the downstream end of the handle using a hose cuff **155**. Optionally, the hose cuff **155** may be configured to allow rotation of the hose relative to the handle.

Referring to FIGS. **1** and **28**, in the illustrated embodiment, the downstream end of the hose **7** is mounted to the surface cleaning unit **4** by a hose coupling **156** that includes one rotatable coupling. In this configuration, the downstream end **157** of the coupling **156** is rotatably connected to the surface cleaning unit **4** and can rotate about axis **158**. The upstream end **159** of the connector **156** is non-rotatably coupled to the downstream end of the hose **7**. In an alternative embodiment, the connector at the upstream end of the coupling **156** may also be rotatable.

The hose coupling may be any suitable member, including for example a straight conduit and a curved conduit. If the hose coupling is a straight conduit the axes of rotation of its upstream and downstream couplings may be parallel and/or coaxial with each other. Alternatively, if the hose coupling is curved the axis of rotation of its upstream and downstream rotatable connectors may be at an angle to each other. The angle between the axes of rotation may be between about 10° and about 170°, and preferably may be between about 45° and about 135°. In the illustrated example the hose coupling is a curved or elbow-type conduit, in which the axes of rotation of its upstream and downstream connectors are at approximately 90° to each other.

Alternatively, instead of being provided as a separate conduit member, the hose coupling may be integral to the surface cleaning unit **4** (for example integral with the air inlet of the air treatment member) and the hose may be directly, and optionally rotatably, coupled to the surface cleaning unit **4**.

Electrified Hose

The following is a description of an electrified, stretchable suction hose that may be used by itself in any surface cleaning apparatus or in any combination or sub-combination with any other feature or features disclosed herein. Advantageously, an electrified hose may be mounted directly or indirectly to a removably mounted surface cleaning unit **4** and removable therewith from a base. Accordingly, when the surface cleaning unit is used in a hand-carriable configuration, the electrified hose may still be electrified and used to power a tool.

Optionally, at least one of the hoses on the vacuum cleaner (the hose **7** and the hose **113**) may include one or more electrical conductors (e.g. wires) that can carry electrical power and/or control or data signals between the ends of the hose. Preferably, at least one of the hoses may also be an extensible or stretch-type hose that can be extended (preferably resiliently extended) while the vacuum cleaner is in use while still providing a continuous electrical connection. Optionally, the conductors within the hose may be limited to carrying electrical power and the transmission of control or data signals may be accomplished using another suitable means. For example, the means for transmitting the

control or data signals may be a wireless transmitter, which may help reduce the need to provide separate data conductors in addition to the hose.

Providing electrical conductors **160** within the hose **7** and/or **113** may allow the hose to transmit electrical signals (power and/or control signals) between its upstream and downstream ends. Optionally, the conductors may be attached to the inner surface of the hose (i.e. within the air flow path), attached to the outer surface of the hose or, as illustrated in FIG. **67**, may be incorporated within the sidewall of the hose **7**. This may eliminate the need for a separate wire or other power transfer apparatus to be provided in addition to the hose and/or to run in parallel with the hose. Reducing the need for external power or control wires may reduce the chances that the exposed electrical wires may be damaged, unintentionally disconnected during use or otherwise compromised.

Providing electrical conductors **160** within the hose **7** may allow the hose **7** to serve as a primary, and optionally only, electrical connection between the surface cleaning unit **4** (or any other portion of the vacuum cleaner that is connected to an external power supply) and the rest of the vacuum cleaner upstream from the hose. Optionally, in configurations in which the surface cleaning unit **4** is the only portion of the vacuum cleaner connected to the electrical power cord which is plugged into the wall, the hose **7** may serve as the primary electrical conduit for carrying power and/or control signals to the surface cleaning head, a plurality of cleaning tools, auxiliary tools, lights, sensors, power tools and other components that are connected to the upstream end of the hose **7** and used in combination with the surface cleaning unit.

Transmitting power via the hose **7** may also allow the hose to be used to supply power to cleaning tools and/or other power tools which may eliminate the need to provide a separate power connection for the tools or to require the use of batteries or an air turbine. For example, using an electrified hose to supply electrical power may allow the surface cleaning head **3** to be powered in a variety of different cleaning configurations, including those in which it is not directly physically coupled to the surface cleaning unit (other than via the suction hose—see, for example FIG. **8**).

Optionally, some or all of the upper portion **2** may also be configured to include conductors, such as wires **126** (FIG. **54**) to transmit power and/or signals. This may help provide an electrical connection between the upstream end of the hose **7** and other portions of the vacuum cleaner.

In the illustrated embodiment, the handle **17**, upper wand portion **101**, hinge **103**, lower wand portion **102** and surface cleaning head **3** are provided with electrical connections via the connectors **146** described previously. Providing electrical connections between the portions of the upper section **2** allows power to be transmitted from the upstream hose cuff **155** to the surface cleaning head **3** (for example to power a rotating brush assembly) via the upper portion **2** and without the need for a separate electrical wire or connection. In this embodiment, the surface cleaning head **3** (or any other accessory or tool) can be powered when connected to the lower wand portion (FIG. **1**), the upper wand portion (FIG. **16**), and the handle (FIG. **8**).

Optionally, the surface cleaning unit **4** can include a main or master on/off electrical switch **161** that controls the supply of power received from the wall socket (or any other type of external power source that is connected to the surface cleaning unit, including, for example, an external battery). Preferably, the main power switch **161** controls the supply of power to the suction motor **8** and other components within

the surface cleaning unit **4**. Optionally, a power conduit can be provided connecting the master on/off switch **161** to the electrified hose **7** via a rotatable electrical connection between the hose coupling **156** and the surface cleaning unit **4**. The rotatable electrical connection on the coupling **156** may be any suitable connection.

Referring to FIG. **28A**, the surface cleaning unit **8** includes an electrical cover **162** for containing and protecting the electrical connection between the coupling **156** and the surface cleaning unit **4**. Referring to FIG. **68**, one example of a rotatable electrical connection includes a pair of extensible wires **163** connected to the surface cleaning unit **4** and the hose **7**. When the coupling is in an aligned position (FIG. **69**) the wires **163** can contract and can accumulate behind the cover **162**. When the coupling **156** is pivoted (FIG. **68**) the wires **163** can stretch to accommodate the additional length required.

Alternatively, referring to FIGS. **70** and **71**, another embodiment of a rotatable electrical connection includes a pair of electrified tracks **164** positioned beneath the cover **162** (shown cut away for clarity). A pair of shoes **165** can follow the tracks **164** and can be connected to the coupling by brackets **166**. The brackets **166** can be conductive, or can carry wires. The shoes **165** and brackets **166**, and can sweep from one end when the coupling **156** is aligned (FIG. **70**) to the other end when the coupling is rotated (FIG. **71**). The ends of the brackets **166** can be electrically connected to the end of the hose **7**, to energize the hose.

Referring again to FIG. **28B**, when the master switch **161** is off, the surface cleaning unit **4** and the hose **7** can be de-energized. When the master switch **161** is on, the surface cleaning unit **4** and hose **7** can be energized.

Optionally, one or more auxiliary electrical switches can be positioned electrically downstream from the master on/off switch **161**. Providing one or more auxiliary switches may allow a user to independently control the supply of electricity to different portions of the surface cleaning apparatus. The auxiliary switches may be connected in parallel with each other and/or in series with each other.

Referring to FIG. **61**, in the illustrated embodiment an auxiliary power switch **167** is provided in electrical communication between the master power switch **161** and the surface cleaning head **3**. In this configuration, the supply of power to the surface cleaning head **3** can be controlled via the auxiliary switch **167**. This allows the surface cleaning head **3** to be selectively energized or de-energized while the surface cleaning unit **4**, and the suction motor **8** therein, remain energized. Using the auxiliary switch **167**, a user can trigger the rotating brush within the surface cleaning head when cleaning one surface (e.g. a carpet) and can turn off the rotating brush when cleaning another surface (e.g. a smooth floor) without interrupting the suction supplied by the surface cleaning unit **4**.

The auxiliary switch **167** can be located at any position that is electrically connected to the master power switch **161** and the surface cleaning head **3**. In the illustrated embodiment, the auxiliary power switch **167** is provided on the handle **17**, and is generally adjacent the hand grip portion **168**. This may allow a user to trigger the auxiliary switch **167** while grasping the hand grip **168**. Alternatively, the auxiliary power switch may be provided in another location, including, for example on the surface cleaning unit, on the surface cleaning head, on the upper or lower wand portion, on the hand grip, or on the cuff or other portion of the upstream end of the hose.

In the illustrated embodiment, if the switch **167** is off then no power is provided past the handle **17**.

Control Circuit

The following is a description of a control circuit that may be used by itself in any surface cleaning apparatus or in any combination or sub-combination with any other feature or features disclosed herein.

Optionally, in addition to the motor for driving a rotating brush, the surface cleaning head 3 may include one or more additional powered features. For example, referring to FIG. 3, the surface cleaning head 3 may include lights, such as LEDs 169 for illuminating the surface being cleaned. It may be desirable to allow a user to turn the brush motor on and off as required, while leaving the LEDs illuminated without increasing the number of conductors provided in the hose 7 or other portions of the upper portion 2. Optionally, a switching circuit can be provided that may allow the LEDs to remain powered regardless of the state of the motor driving the rotating brush. One example of a suitable switching circuit is explained below, with reference to FIG. 72-74.

Reference is first made to FIG. 72 illustrating a switching circuit 700 according to an embodiment. Switching circuit 700 comprises a power source 702, a first diode 704, a second diode 708, a first load 706, a diode bridge 722, a resistor 718 and a second load 720.

Power source 702 provides a DC power signal. Power source 702 may be any type of DC power source. For example, power source 702 may be a battery, an AC-DC converter or adapter that receives power from an AC power source such as a standard utility power supply or any other type of DC power source. The power source may be the surface cleaning unit 4.

First load 706 may be a motor (for example to motor driving the rotating brush in the surface cleaning head 3). First load 706 may be any type of a DC motor, such as, for example, a brushless DC motor, a brushed DC motor etc. As illustrated, the first load 706 is connected in series with the first diode 704 and the second diode 708. The serial arrangement of the first diode 704, the first load 706 and the second diode 708 is connected in parallel to the power source 702.

Diode bridge 722 includes diodes 710, 712, 714, 714 connected in a bridge configuration. The diode bridge 722 is coupled to the second load 720 as illustrated. Second load 720 may be a light emitting diode (LED).

In the illustrated embodiment, the diode bridge 722 is coupled to the second load 720 via resistor 718. In some cases, the diode bridge 722 may be connected to the second load 720 directly. In some other cases, the diode bridge 722 may be coupled to the second load 720 via other electrical components, such as, for example, an inductor, a zener diode etc.

The diode bridge 722 is connected in parallel to the power source 702 as well as the serial arrangement of the first diode 704, the first load 706 and the second diode 708.

Switching circuit 700 is configured so that the power supply to the first load 706 can be switched on and off, whereas the power supply to the second load 720 is always switched on. The power supply to the first load 706 is switched on and off based on the polarity of the power source 702 as illustrated in FIGS. 73A and 73B. For convenience, analogous components are denoted by analogous reference numerals.

Reference is next made to FIG. 73A illustrating a switching circuit 1700. Switching circuit 1700 illustrates a current flow diagram of switching circuit 700 of FIG. 72 where the power source 1702 is connected such that the positive side of the power source is on the anode 1704a of the first diode

1704 and the negative side is on the cathode 1708b of the second diode 1708. The current flow is illustrated by the direction of arrows.

In this configuration, the first diode 1704 and the second diode 1708 become forward biased or conductive closing the circuit path including the power source 1702, first diode 1704, the first load 1706 and the second diode 1708. This closed circuit path allows current to flow to the first load 1706.

In this configuration, diodes 1710 and 1714 of the diode bridge 1722 also become conductive closing the circuit path including the power source 1702, diode 1710, resistor 1718, the second load 1720 and diode 1714. This closed circuit path allows current to flow to the second load 1720.

Reference is next made to FIG. 73B illustrating a switching circuit 250. Switching circuit 250 illustrates a current flow diagram of switching circuit 700 of FIG. 1 where the power source 1702 is connected such that the positive side of the power source is on the cathode 1708b of the second diode 1708 and the negative side is on the anode 1704a of the first diode 1704. The current flow is illustrated by the direction of arrows.

In this configuration, the first diode 1704 and the second diode 1708 remain non-conductive and impede the flow of current to the first load 1706. In other words, the circuit path including the power source 1702, the first diode 1704, the first load 1706 and the second diode 1708 is an open path. The first load 1706 is accordingly switched off.

In this configuration, diodes 1712 and 1716 of the diode bridge 1722 also become conductive closing the circuit path including the power source 1702, diode 1712, resistor 1718, the second load 1720 and diode 1716. This closed circuit path allows current to flow to the second load 1720. Accordingly, in this configuration the first load 1706 is switched off and the second load 1720 is switched on.

Reference is next made to FIG. 74 illustrating a switching circuit 300 according to another embodiment. Switching circuit 300 comprises a first diode 304, a second diode 308, a first load 306, a diode bridge 322, resistor 318 and a second load 320, all of which operate in the same manner as corresponding components of switching circuit 700.

Switching circuit 300 further comprises a switch 330. As illustrated, switch 330 is coupled between the power source 302 and the anode 304a of the first diode 304. In some other cases, switch 330 may be included anywhere between the power source 302 and the rest of the circuit components. For example, switch 330 may be coupled between the power source 302 and the cathode of the second diode 308.

In use, when the switch 330 is closed, the circuit path including the power source 302 and the serial arrangement of the first diode 304, the first load 306 and the second diode 308 is closed. The circuit path including the power source 302, the diode bridge 322, resistor 318 and the second load 320 is also closed. Accordingly, in this configuration, switching circuit 300 operates in the same manner as switching circuit 700 in that the power supplied to the first and the second loads 306 and 320 depends on the polarity of the power source 302.

In the configuration illustrated in FIG. 74, where the switch 330 is open, there is no closed circuit path between the power source 302 and the remaining components of the switching circuit 300. Accordingly, the current flow to both the first load 306 and the second load 320 is impeded, thereby switching off both of the first load 306 and the second load 320.

Electrically Powered Auxiliary Tool

The following is a description of the use of the hose or wand to power an auxiliary tool (such as a mini-cleaning head or power tool such as a sander) that may be used by itself in any surface cleaning apparatus or in any combination or sub-combination with any other feature or features disclosed herein.

In some embodiments, it may be desirable to connect the hose cuff **155** and/or wand directly to an auxiliary tool, and optionally, an auxiliary tool that can be powered by the hose **7**. In such configurations, a second auxiliary power switch **170** may be provided, e.g., on the hose cuff **155** or other portion that is connected to the tool, to allow a user to control the supply electricity of the tool when it is coupled to, e.g., the cuff **155**, without having to use master switch **161** or if a master switch is not provided. In the illustrated embodiment, if the master power switch **161** is on, then the hose **7** is electrified. Preferably, as explained above, the cuff **155** on the upstream end of the hose is configured to include a female or socket-type of electrical connector **153** (FIG. **66**) to receive male electrical prongs **154** provided on the downstream end of the handle **17**. In this configuration, the risk of a user inadvertently contacting the energized electrical contacts on the upstream hose cuff **155** if/when it is detached from the handle is reduced.

Optionally, the surface cleaning apparatus **1** can be configured to avoid disagreement between switches **167** and **170**. Preferably, the switch **170** on the hose cuff **155** can be configured so that it is always “on” when the hose cuff **155** is coupled to the handle **17** (i.e. the socket **153** is always energized when connected). In this configuration, the hose cuff socket **153** will be continuously energized to supply power to the handle **17**, and the switch **167** on the handle **17** can be used to determine if power continues to flow beyond the handle **17**. This allows the user to operate a single switch to control the supply of power beyond the handle, and eliminates the possibility for disagreement between the switches, e.g. a situation in which the handle switch **167** is “on” but no power is available because the switch **170** on the cuff is “off”.

Configuring the hose cuff **155** so that one of the switches **167** and **170** is always on when the cuff **155** is connected to the handle **17** may be done using any suitable circuit or mechanism. In the illustrated example, a limit switch **171** is provided within the handle **17** or the cuff **155**. A driving member **172** is connected to the limit switch **171** and extends into the coupling region. When the hose cuff **155** is attached, the driving member **172** may be driven backward, thereby changing the state of the limit switch **171**. Alternatively, the limit switch may be provided on the hose cuff **155**. The limit switch may be configured according to circuit diagrams of FIGS. **75A** and **75B**.

Reference is next made to FIG. **75** illustrating a connecting circuit **400** according to an example embodiment. Connecting circuit **400** comprises a hose circuit **420** and a handle circuit **430**.

Hose circuit **420** comprises a power source **402**, a limit switch **404**, a hose switch **406** and hose connectors **410a** and **410b**. Handle circuit **430** comprises handle connectors **412a** and **412b** and a handle switch **408**.

As illustrated, limit switch **404** comprises a lever **404a** that is pivotal between contacts **404b** and **404c**. When lever **404a** is coupled to contact **404b**, hose switch **406** remains open. When lever **404a** is coupled to contact **404c**, hose switch **406** closes. Lever **404a** of the limit switch **404** is configured to pivot from contact **404b** to contact **404c** when the connectors **412a** and **412b** of the handle circuit **430**

connect with the connectors **410a** and **410b** of the hose circuit **420**. In some other cases, other types of switches operable by the connection of one circuit, such as, for example, the hose circuit **420**, to another circuit, such as, for example, the handle circuit **430**, may be used.

In some cases, the limit switch **404** may be provided in the handle circuit **430**. In some other cases, two or more limit switches may be provided in the connecting circuit **400**. For example, one limit switch **404** may be provided in the hose circuit **420** and another limit switch **404** may be provided in the handle circuit **430**.

Reference is next made to FIG. **75b** illustrates a connecting circuit **450**. Connecting circuit **450** illustrates the connecting circuit **400** of FIG. **4A** with the hose connectors **410a** and **410b** connected to the handle connectors **412a** and **412b**. The connection of hose connectors **410a** and **410b** with the handle connectors **412a** and **412b** causes the lever **404a** of the limit switch **404** to couple to contact **404c**. This closes the hose switch **406** providing a closed circuit path through it. As illustrated, the handle switch **408** is the primary control switch in the connecting circuit **450**.

An advantage of this design is that a vacuum cleaner may be used to power a power tool, such as a drill or sander, and operated concurrently with the power tool to clean up debris produced during use of the power tool.

Lighted Tools Powered by Electrified Hose

The following is a description of lighted tools that may be used by itself in any surface cleaning apparatus or in any combination or sub-combination with any other feature or features disclosed herein.

Optionally, a light source may be provided in some or all of auxiliary cleaning tools that are used in combination with the surface cleaning apparatus.

Providing a light source on some or all of the tools may allow a user to direct the light onto a surface being cleaned. The light source may also illuminate the downstream end of the accessory that is being connected by the user, which may help a user see the connector details and/or align the accessory for proper assembly, especially in low light conditions. The light source can be any suitable light source, including, for example an incandescent light bulb, a fluorescent light bulb, a light emitting diode (LED), the end of a fiber optic filament and any other suitable source.

Referring to FIG. **15**, an example of a crevice cleaning tool **173** includes an LED **174** configured to illuminate portions of the crevice tool **173** and the surface being cleaned. Preferably, if a tool is equipped with an LED **174**, it is also equipped with a local actuator to control the operation of the light independently of the overall supply of electricity to the cleaning tool. This may allow a user to continuously power an auxiliary tool (like a rotating brush or sander) while selectively turning the LED on or off as desired. In the illustrated embodiment, the crevice tool **173** includes an on/off button **175** that is configured to control the supply of power to the LED **174**. Alternatively, or in addition to using a local switch or button, a user may control the LED by using the power switches **167**, **170** on the handle or hose cuff, as appropriate.

Alternatively, instead of providing the light source on the auxiliary cleaning tools, an LED **174** may be provided in the downstream portion of the connector itself (for example on the upstream end of the handle, FIG. **60** and/or on the hose cuff, FIG. **66**). Preferably, the light source can be provided in the downstream portion of the connector (in the direction of air flow) so that it can remain energized when the connector is separated. A light source on the downstream portion of the connector may be useful to illuminate a

transparent or translucent cleaning tool that is attached to the connector, even if the tool does not have its own onboard light source. For example the crevice cleaning tool can be configured so that when it is connected to the upstream end of the handle (or directly to the upstream cuff on the hose) an LED 174 in the handle (FIG. 60) can illuminate the crevice tool (e.g. via partial internal reflection and/or refraction of the light within the transparent and/or translucent material). Accordingly, the auxiliary tool may comprise a light pipe. This may allow the crevice tool 173 to illuminate its surroundings, for example the crevice between a cushion and a couch frame, which may assist a user in seeing or inspecting the surface to be cleaned.

Battery Operable Surface Cleaning Head

The following is a description of the use of a battery operated surface cleaning head that may be used with a non-electrified hose or with an electrified hose and may be used in any combination or sub-combination with any other feature or features disclosed herein.

Optionally, the surface cleaning head 3 can include a driven rotating brush or agitator for contacting the surface being cleaned. The rotating brush can be positioned adjacent the dirty air inlet and may help dislodge dirt particles from the surface. The rotating brush can be driven using any suitable actuator.

For example, the surface cleaning head 3 may include an electric motor that is configured to drive the rotating brush. Optionally, the electric motor can be an AC motor that is powered by AC electricity when the surface cleaning apparatus is plugged into a power source, such as a standard household socket. The power can be transferred from the surface cleaning unit, which is connected to the electrical cord, to the surface cleaning head via any suitable mechanism. Optionally, the power may be transferred by wires or other conductive members extending from the surface cleaning unit to the surface cleaning head. In the illustrated embodiment, the hose 7 is an electrified hose and the upper portion 2 includes electrical conductors to transfer electricity from the upstream end of the hose 7 to the surface cleaning head 3. This eliminates the need to run separate, external wires between the surface cleaning unit and the surface cleaning head.

Alternatively, instead of routing electricity through the hose and upper portion (for example if the hose does not include any electrical conductors) the surface cleaning apparatus may include a wire running from the surface cleaning unit to the surface cleaning head. In either configuration, the electrical conductors can optionally be configured to carry power and/or control signals to control the operation of the surface cleaning head. In addition to powering the rotating brush, power supplied to the surface cleaning head (via any possible connection method) can also be used to power lights and other accessories.

Optionally, a surface cleaning head can include an on-board energy storage member (e.g., one or more batteries) to provide some or all of the power needed to power the rotating brush and/or other accessories. Referring to FIG. 76, another embodiment of surface cleaning head 9003 is illustrated. The cleaning head 9003 is similar to cleaning head 3, and analogous features may be identified using like reference characters indexed by 9000.

Preferably, the on-board energy storage member is a battery that is sized to fit within the surface cleaning head and is powerful enough to drive the rotating brush. Optionally, when operated on DC battery power, as opposed to external AC power, the rotating brush motor may operate at a reduced rate or may be otherwise configured to reduce

power consumption (e.g., the motor may have dual windings to be operable on both AC and DC power). If required, a converter module 9605 can be provided to convert the external power supply into a format (e.g., DC) that is compatible with motor 9602, configured to re-charge the batteries 9603 or is otherwise preferred over the native incoming format.

Referring to FIG. 76, the surface cleaning head 9003 includes rear wheels 9600 and an outer cover 9601. Referring also to FIG. 77, the surface cleaning head 9003 includes a motor 9602 for driving a rotating cleaning brush, and batteries 9603 for powering the motor 9602 when the external power is not available. A switch 9604 is provided to control the motor 9602 when it is being powered by the batteries 9603.

Providing a battery 9603 in the surface cleaning head may allow the cleaning head 9003 to remain powered even in configurations in which the electrical connection between the surface cleaning unit 4 and the surface cleaning head 9003 is interrupted. This may allow the surface cleaning head 9003 to remain powered in a variety of operating modes, regardless of the position and/or configuration of the surface cleaning unit 4.

The battery 9603 in the surface cleaning head may be any suitable type of battery, including a rechargeable battery. Optionally, when the surface cleaning unit 4 is electrically connected to the surface cleaning head 9003, power from the surface cleaning unit 4 may be used to re-charge the battery 9603 within the surface cleaning head 9003, to directly power/drive the rotating brush motor 9602 or to simultaneously run the brush motor 9602 and re-charge the battery 9603. In this configuration, when the vacuum is operated in the traditional, upright mode the battery 9603 in the cleaning head can 9003 be charged and the brush motor 9602 can be driven by AC power and/or a combination of AC and battery power. Then, when the surface cleaning unit 4 is electrically decoupled from the surface cleaning head 9003 (for example when the surface cleaning unit is separated from the upper portion), the surface cleaning head 9003 can be operated on battery power.

Surface Cleaning Unit Locked when Handle is Gripped

The following is a description of a lockout member that may be used by itself in any surface cleaning apparatus or in any combination or sub-combination with any other feature or features disclosed herein and preferably with the automatic unlocking system discussed previously.

In accordance with one aspect of the teachings described herein, a surface cleaning unit supplemental lock or lockout apparatus may be provided to selectively prevent the surface cleaning unit 4 from being detached from the upper portion 2 and/or to prevent the cyclone bin assembly from being detached from surface cleaning unit 4.

In one embodiment, the lockout apparatus can be automatically triggered based on an operating condition or state of use of the surface cleaning apparatus 1. For example, it could be engaged when the upper portion of a surface cleaning apparatus is moved to the storage position. Optionally, the supplemental lock mechanism may be configured to directly lock the surface cleaning unit 4 to the upper portion 2 (e.g., an engagement member of the mechanism could engage the surface cleaning apparatus to prevent the surface cleaning unit from being detached from the surface cleaning apparatus. Alternatively, or in addition, the supplemental lock mechanism may be configured to engage the primary surface cleaning unit lock and prevent its deactivation/disengagement.

57

When the surface cleaning unit **4** is locked to the upper portion **2**, for example as shown in FIG. **1**, a user may wish to lift the entire surface cleaning apparatus **1** using handle **547**. For example, a user may wish to carry the surface cleaning apparatus **1** up or down stairs, or place it in storage. During such activities, lifting via the handle may be preferred to lifting via handle **17**. If the surface cleaning unit **4** were to become unlocked while it is being used to carry the entire surface cleaning apparatus it is possible that the upper portion **2** may become detached and fall to the ground. This may pose a safety concern, particularly on stairs.

Referring to FIGS. **28A** and **28B**, in the illustrated embodiment the surface cleaning unit **4** is locked to the upper portion **2** by the engagement of latch **70** with slot **71**. To unlock the surface cleaning unit **4**, the latch **70** can be shifted downward, by pressing release button **73**, to disengage the latch **70** from the slot **71**. In this embodiment, the button **73** is provided in close proximity to the handle **546** on the surface cleaning unit **4**. If button **73** were accidentally pressed while the entire surface cleaning apparatus **1** is being carried via handle **546** it may result in the upper portion **2** falling off of the surface cleaning unit **4**.

Optionally, a supplemental lock mechanism can be incorporated into the surface cleaning apparatus **4**, upper portion **2** or both, to help prevent unwanted unlocking of the surface cleaning unit **4**. Preferably, the supplemental lock mechanism can be automatically engaged when a user lifts the surface cleaning apparatus **1** via the handle **546**, without requiring the user to independently operate a lock or latch mechanism.

Referring to FIG. **78**, a schematic representation of another embodiment of a surface cleaning apparatus **1** is illustrated including an embodiment of a lockout apparatus **800**. The lockout apparatus **800** includes a trigger **801** that is configured to be activated when a user grasps the handle **547**. The trigger **801** is connected to a lockout member **802** that is operable to physically interfere with depressing the release button **73**. Preventing button **73** from being depressed can prevent the latch **70** from disengaging slot **71** (FIGS. **28A** and **28B**), and thereby can prevent the surface cleaning unit **4** from being unlocked.

In the illustrated embodiment, the trigger **801** is provided in the form of a plate **803** that forms part of the underside of the handle **547**. The plate **803** can translate between a lowered position (FIG. **78A**) and a raised position (FIG. **78B**) when the user grasps the handle **547**. The plate **803** may be biased toward its lowered position using any suitable mechanism. In the illustrated example, the plate **803** is biased downwardly by a spring **805**.

The plate **803** is connected to a linkage member **806** that connects the trigger **801** to the lockout member **802**. In the illustrated embodiment, the linkage member **806** is provided in the form of a mechanical linkage **807** that is positioned within the lid **546** and can translate with the plate **803**.

The mechanical linkage **807** is a shaped rod having one end connected to the plate **803** and the other end abutting the lockout member **802**. In the illustrated example, the lockout member **802** includes a slidable pin **808** that can be inserted into a corresponding slot **809** in the body of the release button **73** (or any linkage member or movable component connected thereto). When the plate **803** is in its lowered position (FIG. **78A**) the pin **808** is retracted from and is clear of slot **809**. This allows the button **73** to translate vertically without interference.

When the plate **803** is moved to its raised position (FIG. **78B**), the linkage **807** urges the pin **808** into the slot **809**. The slot **809** is sized so that it can only partially receive the pin

58

808 or the linkage is configured to only partially insert the pin, leaving an exposed portion **810** extending outside the slot **809**. If the button **73** is pressed in this configuration, the exposed portion **810** of the pin **808** abuts against and interferes with a fixed restraining shoulder **811**, thereby preventing downward movement of the button **73**.

When the user releases the handle **547**, the plate **803** will be biased toward its lowered position, thereby moving linkage **807** and allowing pin **808** to be withdrawn from slot **809** (via gravity in the example illustrated).

If a user wishes to remove the surface cleaning unit **4** from the upper portion **2**, the user may depress the button **73** before grasping the handle **547**. In this configuration, moving button **73** will shift the slot **809** out of alignment with the pin **808**. When a user subsequently grasps the handle **547**, plate **803** will exert an upward force on linkage **807** which will act against pin **808**. With the slot **809** misaligned, pin **808** will bear against a solid portion of the button **73**, and will not translate. This will prevent the linkage **807** from moving upward, which will prevent the plate **803** from moving upward. Instead, the plate **803** will remain in its lowered position as the user carries the surface cleaning unit **4**.

Alternately, plate **803** may only translate upwardly when the force applied to plate **803** is indicative that a user has used the handle to lift the surface cleaning unit. For example, spring **805** may not be compressed when a user lifts only the cyclone bin assembly and/or the surface cleaning unit using handle **4**.

Referring to FIGS. **79A** and **79B**, another embodiment of the lockout apparatus **800** is shown. In this embodiment, the trigger **801** includes plate **803** and spring **805**, and the linkage mechanism **806** includes a mechanical linkage **807** that connects the plate **803** to the interlock member **802**.

In this embodiment, the interlock member **802** includes a rotating latch member **813**, instead of a mating pin and slot combination. The latch member **813** is pivotally mounted within the lid **546** and is moveable between an engage position (FIG. **79A**) and a retracted position (FIG. **79B**).

In the retracted position, the latch member **813** is received within the lid **546** and does not engage the button **73**. In the engage position (FIG. **79A**) a projection **814** on the latch member **813** is inserted into a corresponding notch **815** on the button **73** (or any connected, movable member). When the projection **814** is nested within notch **815** the button **73** cannot be depressed.

If the button **73** is not depressed when a user grasps the handle **547**, the plate **803** will be translated upward, thereby shifting linkage **807** and pivoting the latch member **813** into engagement with the button **73**. If the button **73** is subsequently pressed, it cannot move downward (as illustrated) and the surface cleaning unit **4** cannot be unlocked.

If the button **73** is depressed before a user grasps the handle **547**, the opening **816** in the button **73** that includes the notch **815** will be moved out of alignment with the latch member **813**. If the handle **547** is subsequently grasped, rotation of the latch member **813** will be prevented by interference between the latch **813** and the sidewall **817** of the button **73**, which will prevent movement of the linkage **807** and the plate **803**.

The lockout system may be mechanical, electro-mechanical or electrical. For example, instead of a mechanical pin **808**, and a mechanical linkage, the interlock member **802** can include any suitable member, including for example a solenoid, cam member or other member which may be actuated by a mechanical linkage or a sensor that sends a signal, wired or wirelessly, to the lockout member.

For example, referring to FIGS. 80A and 80B, another embodiment of a lockout apparatus mechanism 1800 is shown. Lockout apparatus 1800 is similar to mechanism 800, and analogous features are identified using like reference characters indexed by 1000.

In the illustrated embodiment, the lockout apparatus 1800 includes a trigger 1801, a linkage member 806 and an interlock member 802 that prevents removal of the surface cleaning unit 4 from the upper portion 2. In this configuration, the trigger 1801 includes a movable plate 1803 that is biased downwardly by spring 1805.

The linkage member 1806 is provided in the form of an electro-mechanical system that includes an electrical switch 1817 that is connected to a solenoid 818 via a wire 1819. Power for the system can be provided from any suitable source, including the surface cleaning unit 4. The plate 1803 includes an extension member 1820 that triggers the switch 1817 when the plate 1803 is moved upwards (FIG. 80B).

When the switch 1817 is triggered, the solenoid 1818 is energized and solenoid pin 1821 extends into a corresponding slot 1822, thereby preventing downward movement of the button 73.

While illustrated with respect to the locking mechanism that is used to lock the surface cleaning unit 4 to the upper portion 2, including button 73, a lockout apparatus may also be used to interfere with operation the locking mechanism that locks the cyclone bin assembly 9 to the motor housing 12. This may prevent the cyclone bin assembly 9 from separating from the motor housing 12.

Optionally, the lockout apparatus can be configured to interfere with both locking mechanisms, thereby preventing separation of the surface cleaning unit 4 from the upper portion 2 and separation of the cyclone bin assembly 9 from the motor housing 12. It may also be used in combination with any other suitable locking mechanism on the surface cleaning apparatus 1.

Information Display System

The following is a description of an information display system that may be used by itself in any surface cleaning apparatus or in any combination or sub-combination with any other feature or features disclosed herein.

In accordance with one aspect of the teachings described herein, the surface cleaning apparatus may include a user information display or feedback system. Preferably, the information display system may be operable to detect at least one state or operating condition of the surface cleaning apparatus and provide corresponding feedback to the user.

For example, the surface cleaning apparatus 1 may include a user information system that includes one or more sensors on various portions of the surface cleaning apparatus to detect machine conditions (in use vs. in storage, dirt bin capacity, filter quality, etc.) and/or environmental factors (type of surface being cleaned, etc.). The sensors can be connected to any suitable controller (such as PLC, micro-processor, etc.). The controller can also be connected to one or more output transducers and/or information display elements. Based on the inputs from the sensors, the controller can trigger an appropriate transducer to convey some type of information to a user.

Referring to FIG. 81, the surface cleaning apparatus 1 is illustrated with schematic representation of an information system 900 that includes a plurality of sensors 901 and transducers 902. Referring to FIG. 82, a schematic block diagram of the system 900 is illustrated, including transducers 901, sensors 902 and a suitable controller 903. In addition to the transducers 902 and sensors 901, the controller may accept additional inputs 905 (such as the state of

the suction motor or rotating brush motor) and may output additional outputs 904 (such as a control signal for the suction motor or the brush motor).

The sensors 901 and transducers 902 may be any suitable mechanisms, and output from one sensor may trigger one or more corresponding transducers 902, as dictated by the controller.

For example, in the illustrated embodiment, the system 900 includes a sensor 901a on the surface cleaning head 3 to detect the type of surface being cleaned. The sensor 901a may be an optical sensor, a distance sensor, a torque sensor for a rotating brush, or any other sensor that can detect a difference in flooring type (e.g. carpet vs. smooth flooring). In this configuration, if the sensor 901a detects that the cleaning head 3 is on carpet, then the controller 903 may trigger the transducer 902a that is positioned on the handle 17 next to the switch 167 that allows a user to turn on the rotating brush in the cleaning head 3. The transducer 902a may be any suitable apparatus, including, for example, a light source (LED), a speaker, a buzzer, a vibrating device, and any other type of output mechanism. In the illustrated example, the transducer 902a is an LED light source that illuminates to draw a user's attention to the switch 161. Optionally, instead of being positioned adjacent the switch 161, the LED 902a may be incorporated within the switch 161 so that the switch 161 itself glows. Optionally, the rotating brush may be de-energized when a bare floor is detected and the LED may indicate that the brush is "off" by illuminating a "brush off" button or light.

The surface cleaning unit 4 may include a dirt bin sensor 901b that is configured to detect when the dirt collection chamber 11 is at capacity. The sensor 901b may be any suitable sensor, including an optical reflection sensor that includes an emitter/receiver 906 and a reflector 907 (which may be integral with the cyclone bin assembly 9). When the light path between the emitter 906 and the reflector 907 is blocked by debris the controller 803 may recognize that the dirt collection chamber 11 is full. The controller may then trigger transducer 902b which is an LED for illuminating the dirt collection chamber 11 to draw a user's attention (but may be any other type of transducer). The LED 902b may illuminate the outside of the dirt chamber 11, the inside of the chamber 11 or, if the wall is transparent, may illuminate the inside of the chamber wall so that the dirt collection chamber appears to glow. Optionally, the controller may also trigger LED 902c (which may alternatively be other types of transducers) which are located inside the main power switch 161 to suggest to a user that the power be turned off so that the dirt collection chamber 11 can be emptied. Alternately or in addition, a LED may indicate that the bin is full by illuminating a "bin full" button or light.

A sensor 901c may be provided proximate the pivot joint (for example a micro switch or proximity sensor) to detect when the upper portion 2 is pivoted into the use position. The controller 803 may then activate suitable transducers, such as LED transducer 902d that is provided on the handle 17 adjacent the hinge release button 119, alerting a user that the user may wish to unlock the hinge 103. Alternately or in addition, a LED may indicate that the hinge could be released by illuminating a "release hinge" button or light.

Another suitable transducer 902 may be a display panel 902e, for example and LCD display, that can show information about the surface cleaning apparatus (for example battery charge status, etc.) and may display messages regarding other sensed conditions (e.g. "Dirt Bin Full", etc.).

An airflow or pressure sensor 901d may be provided in the airflow path and may monitor the air flowing therethrough.

61

Changes in pressure, for example due to a blockage or a dirty pre-motor filter, may be sensed and the controller 803 can actuate a suitable transducer. For example, the controller 803 may trigger LED 902f which may illuminate the pre-motor filter chamber (or its sidewalls) to alert a user to check the condition of the filter. Alternately or in addition, an LED may indicate that the pre-motor filter requires cleaning by illuminating a “clean filter” button or light.

A position sensor 901e, such as an accelerometer and/or a gyroscope, may be provided in the surface cleaning unit 4 to detect its orientation. If the surface cleaning unit 4 falls over or is dropped the controller 803 may be operable to turn off the suction motor 8 and/or to send out a warning or alarm sound via a speaker transducer 902f.

Optionally, instead of, or in addition to an alarm sound, the speaker transducer 902f may be configured to provide verbal instructions or warnings to the user based on the sensed data (e.g. “Please empty the dirt bin”)

What has been described above has been intended to be illustrative of the invention and non-limiting and it will be understood by persons skilled in the art that other variants and modifications may be made without departing from the scope of the invention as defined in the claims appended hereto. The scope of the claims should not be limited by the preferred embodiments and examples, but should be given the broadest interpretation consistent with the description as a whole.

What is claimed is:

1. A surface cleaning apparatus comprising:

- (a) a surface cleaning head having a front face, a dirty air inlet and a pedestal member directly pivotally coupled to the surface cleaning head about a rotational axis, the front face facing a forward direction;
- (b) an upper portion mounted to the pedestal member whereby the upper portion is moveable between a storage position and a floor cleaning position, the upper portion including an above floor cleaning wand and a portable surface cleaning unit, the above floor cleaning wand having a longitudinal axis;
- (c) the portable surface cleaning unit comprising a suction motor and an air treatment member, the portable surface cleaning unit is removably mounted to the pedestal member wherein, when the portable cleaning unit is mounted to the pedestal member, the surface cleaning apparatus is in an upright surface cleaning apparatus configuration and, when the portable cleaning unit is mounted to the pedestal member and the upper portion extends upwardly from the pedestal member;
- (d) the above floor cleaning wand is removably mounted to the pedestal member and a flexible air flow conduit forms at least part of an air flow path from the above floor cleaning wand to the portable surface cleaning unit;
- (e) a portable surface cleaning unit lock having a first engagement member and a second engagement member wherein the portable surface cleaning unit lock is operable between a locked position in which the portable surface cleaning unit is secured in position on the pedestal member and an unlocked position in which the portable surface cleaning unit is removable from the position on the pedestal member,

wherein one of the first and second engagement members is provided on the portable surface cleaning unit and another of the first and second engagement members is provided on the

62

pedestal member whereby the portable surface cleaning unit lock secures the portable surface cleaning unit to the pedestal member, and, wherein the only engagement member locking the portable cleaning unit in the upright configuration is on the pedestal member, and,

wherein when the portable surface cleaning unit is secured in position on the pedestal portion, the orientation of the front face of the portable surface cleaning unit with respect to the front face of the surface cleaning head is adjustable about the rotational axis and the orientation of the front face of the portable surface cleaning unit is also adjustable to face a different direction angularly positioned around the longitudinal axis from the forward direction while the front face of the surface cleaning head faces the front direction,

wherein, when the portable surface cleaning unit is secured in position on the pedestal member and the upper portion extends upwardly from the surface cleaning head, a lower end of the above floor cleaning wand is positioned below an upper end of the portable cleaning unit, and

wherein, when the portable surface cleaning unit is secured in position on the pedestal member and the upper portion extends upwardly from the surface cleaning head, an upper end of the pedestal member is positioned adjacent to a lower portion of the portable surface cleaning unit.

2. The surface cleaning apparatus of claim 1 wherein the portable surface cleaning unit lock further comprises a pivotally mounted locking member.

3. The surface cleaning apparatus of claim 1 wherein the portable surface cleaning unit is removably mounted on an outer surface of the pedestal member.

4. The surface cleaning apparatus of claim 1 wherein the portable surface cleaning unit is removably mounted on an outer surface of the pedestal member and the outer surface is provided with an alignment member and the portable surface cleaning unit is mountable to the outer surface in a particular alignment.

5. The surface cleaning apparatus of claim 4 wherein the alignment member inhibits lateral movement of the portable surface cleaning unit when the portable surface cleaning unit is mounted to the outer surface.

6. The surface cleaning apparatus of claim 5 wherein the portable surface cleaning unit release actuator is positioned above the alignment member.

7. The surface cleaning apparatus of claim 1 wherein the pedestal member is in air flow communication with the dirty air inlet and, when the wand is mounted to the pedestal member, the wand is in air flow communication with the dirty air inlet.

8. The surface cleaning apparatus of claim 1 further comprising an air flow passage from the dirty air inlet to the pedestal member and an air inlet end of the wand is aligned with an outlet end of the air flow passage when the wand is mounted to the pedestal member.

9. The surface cleaning apparatus of claim 1 wherein the wand comprises a lower end that is mounted to the pedestal member and an upper end, the lower end comprises a wand air inlet and the upper end comprises a wand air outlet, a handle is provided proximate the upper end of the wand, whereby, when the wand is mounted to the pedestal member, the wand is drivingly connected to the surface cleaning head.