



US010782038B2

(12) **United States Patent**  
**Conrad**

(10) **Patent No.:** **US 10,782,038 B2**

(45) **Date of Patent:** **Sep. 22, 2020**

(54) **FAN COIL APPARATUS INCLUDING A HUMIDIFICATION UNIT AND A HUMIDIFICATION UNIT**

(71) Applicant: **Omachron Intellectual Property Inc., Hampton (CA)**

(72) Inventor: **Wayne Ernest Conrad, Hampton (CA)**

(73) Assignee: **Omachron Intellectual Property Inc., Hampton, Ontario (CA)**

(\* ) Notice: Subject to any disclaimer, the term of this patent is extended or adjusted under 35 U.S.C. 154(b) by 165 days.

(21) Appl. No.: **15/381,959**

(22) Filed: **Dec. 16, 2016**

(65) **Prior Publication Data**

US 2018/0172297 A1 Jun. 21, 2018

(51) **Int. Cl.**

**F24F 6/04** (2006.01)  
**F24F 6/12** (2006.01)  
**F24F 13/22** (2006.01)  
**F24F 13/20** (2006.01)  
**F24F 13/30** (2006.01)  
**F24F 6/00** (2006.01)

(52) **U.S. Cl.**

CPC ..... **F24F 6/04** (2013.01); **F24F 6/12** (2013.01); **F24F 13/20** (2013.01); **F24F 13/22** (2013.01); **F24F 13/30** (2013.01); **F24F 2006/006** (2013.01); **F24F 2006/008** (2013.01)

(58) **Field of Classification Search**

CPC ..... **F24F 6/12**; **F24F 6/14**; **F24F 6/04**; **F24F 13/30**; **F24F 13/20**; **F24F 13/22**; **F24F 2006/008**; **F24F 2006/006**

See application file for complete search history.

(56) **References Cited**

U.S. PATENT DOCUMENTS

2,256,374 A \* 9/1941 Cummings, Jr. .... F24F 3/14 95/216  
2,718,712 A \* 9/1955 Bruker ..... B31F 1/36 34/629  
2,883,511 A \* 4/1959 Gooldy ..... F24D 5/00 239/136  
3,169,575 A \* 2/1965 Engalitcheff, Jr. .... F28D 5/02 62/99

(Continued)

FOREIGN PATENT DOCUMENTS

CA 2746405 C 10/2015  
JP 2015102284 A 6/2015  
WO 2015182548 A1 12/2015

OTHER PUBLICATIONS

"Liquid Water Jet Eductors" Venturi Jet Pumps Ltd published Dec. 12, 2013 accessed at <<https://web.archive.org/web/20131212065801/http://www.venturipumps.com/eductor.htm>> (Year: 2013).\*

(Continued)

*Primary Examiner* — Stephen Hobson

(74) *Attorney, Agent, or Firm* — Philip C. Mendes da Costa; Bereskin & Parr LLP/S.E.N.C.R.L./s.r.l.

(57) **ABSTRACT**

A fan coil assembly comprises a humidification unit and a water recovery system. The water recovery system comprises a member or members that retain water droplets, which may be micro water droplets and optionally collects some or substantially all or all of the droplets that are not evaporated by air passing through the fan coil assembly.

**13 Claims, 32 Drawing Sheets**

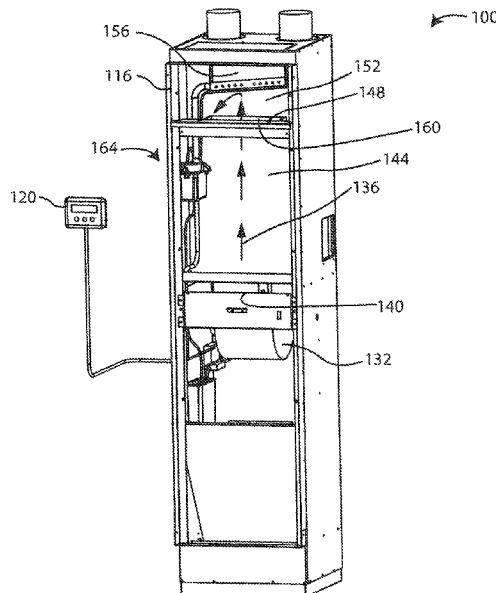

(56)

References Cited

U.S. PATENT DOCUMENTS

3,251,556 A \* 5/1966 Burnham ..... B05B 1/267  
239/338  
3,304,696 A \* 2/1967 McKenna ..... B01D 45/06  
96/126  
3,584,786 A \* 6/1971 Johnson ..... B05B 1/04  
239/568  
3,606,159 A \* 9/1971 Sutton ..... B01D 47/06  
239/127  
3,664,324 A \* 5/1972 Radtke ..... F24H 1/00  
126/113  
3,689,037 A \* 9/1972 Payne ..... F24D 5/00  
261/105  
3,877,459 A \* 4/1975 Harvey ..... B05B 12/12  
126/113  
3,947,940 A \* 4/1976 Augustine ..... B05B 1/265  
29/890.143  
3,990,427 A \* 11/1976 Clinebell ..... F24F 6/12  
126/113  
4,238,425 A \* 12/1980 Matsuoka ..... B05B 17/0615  
220/501  
4,239,956 A \* 12/1980 Morton ..... F24F 6/18  
126/113  
4,572,428 A \* 2/1986 Groff ..... F24F 6/14  
236/44 A  
RE33,414 E \* 10/1990 Morton ..... F24F 6/18  
126/113  
5,294,235 A \* 3/1994 Stutzle ..... C05F 17/964  
96/240  
5,389,120 A \* 2/1995 Sewell ..... B01D 47/06  
96/233  
5,407,604 A \* 4/1995 Luffman ..... B01F 3/0407  
261/4  
5,497,633 A \* 3/1996 Jones ..... B05B 7/0075  
62/259.4  
5,543,090 A \* 8/1996 Morton ..... F24F 6/18  
261/118  
5,653,919 A \* 8/1997 White ..... B01F 3/04021  
261/21  
5,699,983 A \* 12/1997 Ellsworth ..... B64D 13/00  
244/118.5

5,806,762 A \* 9/1998 Herr ..... B05B 1/3006  
236/44 A  
5,859,952 A \* 1/1999 Levine ..... F24F 1/02  
239/102.1  
5,893,520 A \* 4/1999 Elkas ..... B05B 1/00  
239/499  
6,227,526 B1 \* 5/2001 Morton ..... F24F 6/18  
239/139  
6,293,121 B1 \* 9/2001 Labrador ..... B01D 61/10  
62/304  
6,990,748 B2 \* 1/2006 Magoon ..... F26B 3/26  
34/197  
7,513,486 B2 \* 4/2009 Bachert ..... F24F 6/043  
250/436  
7,552,914 B1 \* 6/2009 Feldstein ..... F24F 6/14  
261/4  
8,002,904 B2 \* 8/2011 Ragozzino ..... B08B 9/032  
134/166 R  
8,977,115 B2 \* 3/2015 Penman, Jr. .... A61L 2/208  
392/386  
2005/0212152 A1 \* 9/2005 Reens ..... F24F 6/12  
261/81  
2008/0079179 A1 \* 4/2008 Lundgreen ..... F24F 6/18  
261/79.2  
2009/0084861 A1 \* 4/2009 Arote ..... F24F 3/14  
236/44 A  
2015/0115053 A1 \* 4/2015 Kopel ..... F24F 6/18  
239/1  
2015/0128483 A1 \* 5/2015 Krupp ..... F24D 5/04  
43/132.1  
2016/0187015 A1 \* 6/2016 Lee ..... B01F 3/04  
261/139  
2017/0056915 A1 \* 3/2017 Hayden ..... B01F 3/04085  
2017/0082306 A1 \* 3/2017 Murakami ..... F24F 6/00  
2017/0157527 A1 \* 6/2017 Kopel ..... F28B 9/08  
2018/0094825 A1 \* 4/2018 Peczalski ..... F24F 13/22

OTHER PUBLICATIONS

English machine translation of JP2015102284A, published on Jun. 4, 2015.

International Search Report and Written Opinion, received in connection to PCT/CA2017/051370.

\* cited by examiner

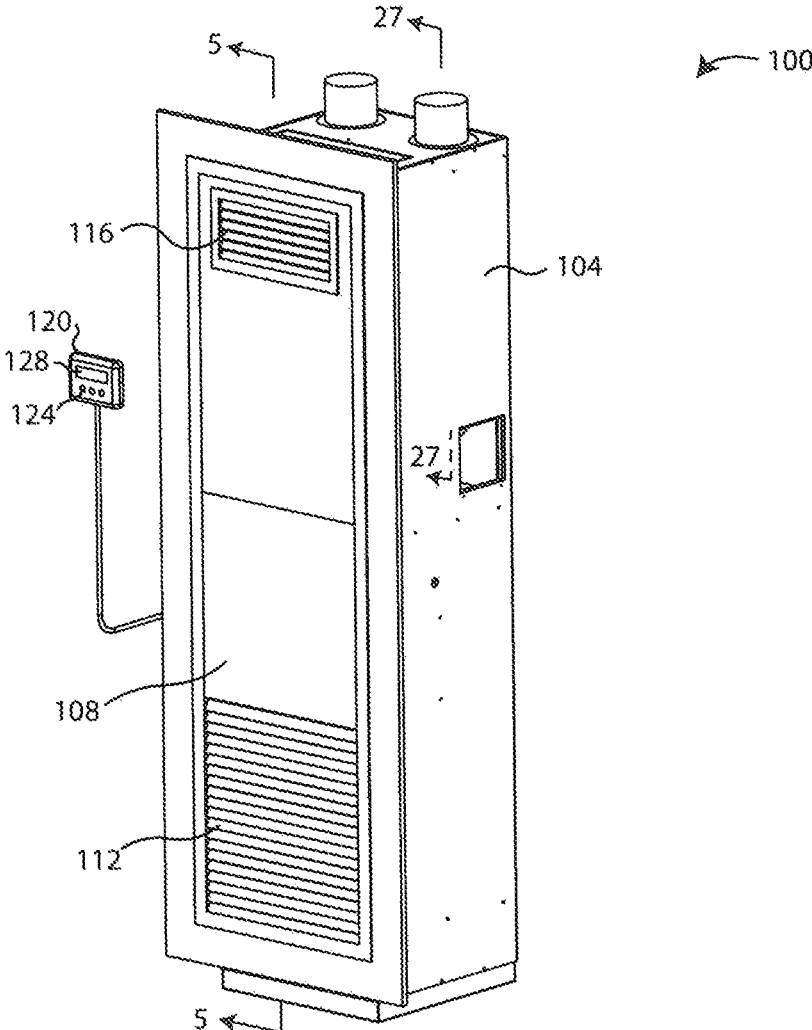

FIG. 1

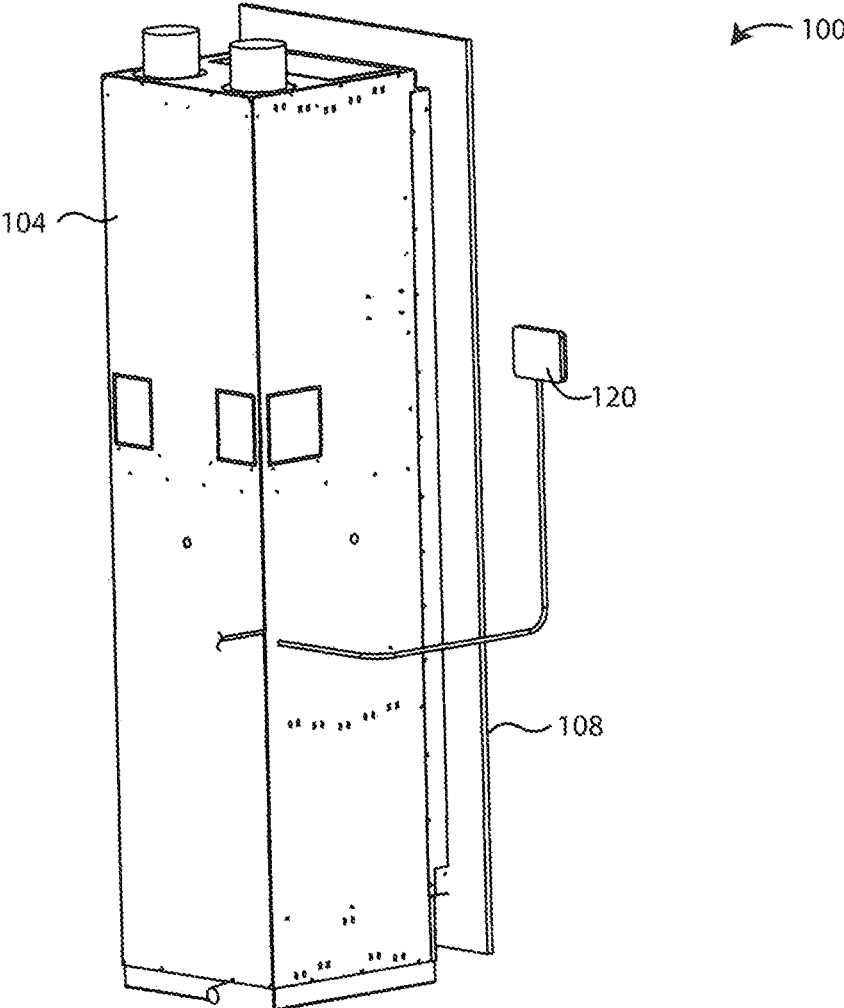

FIG. 2

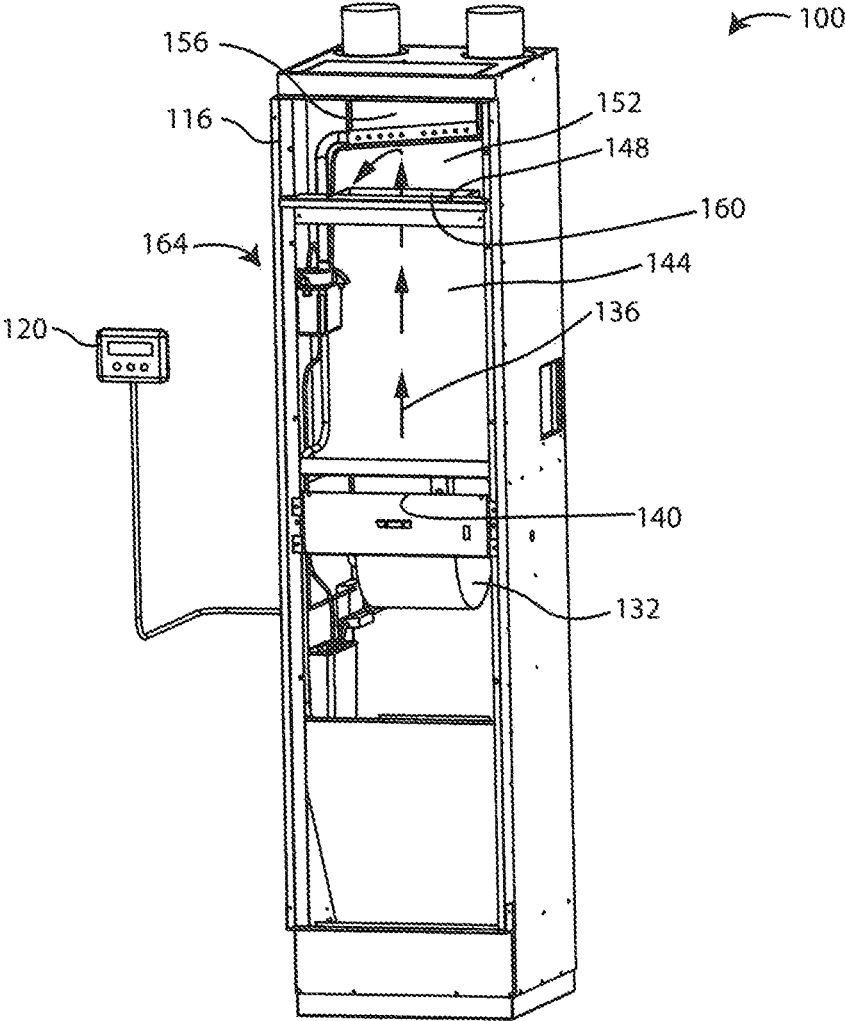

FIG. 3

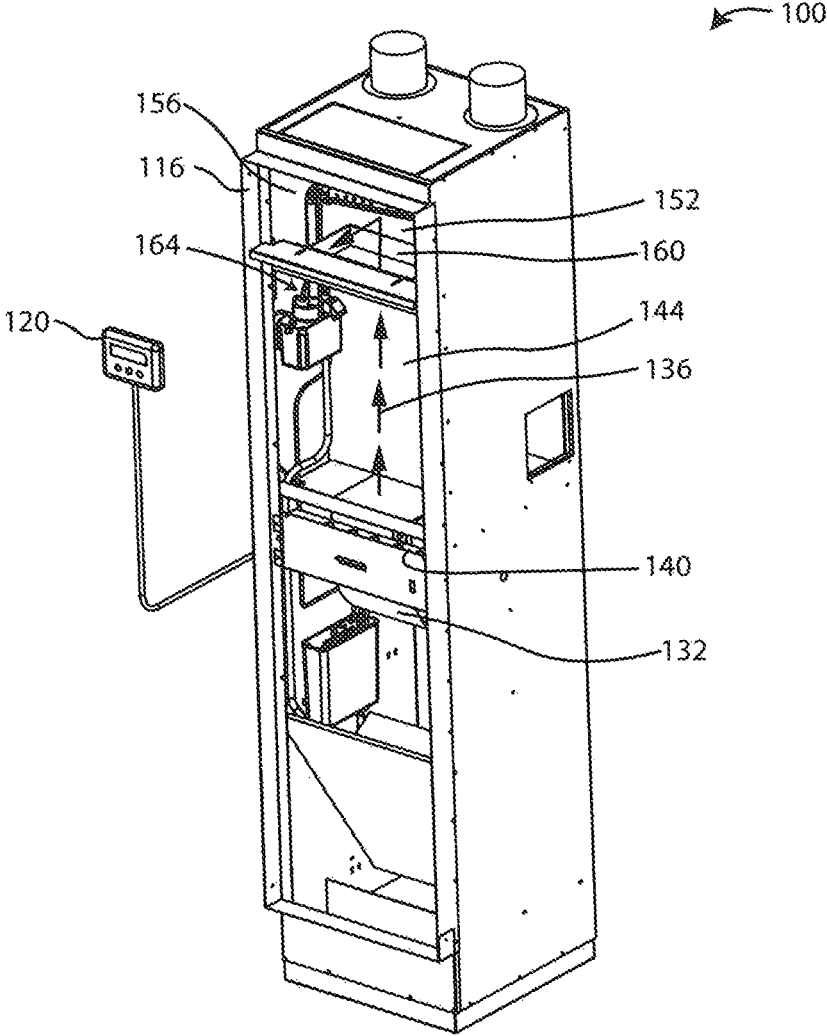

FIG. 4

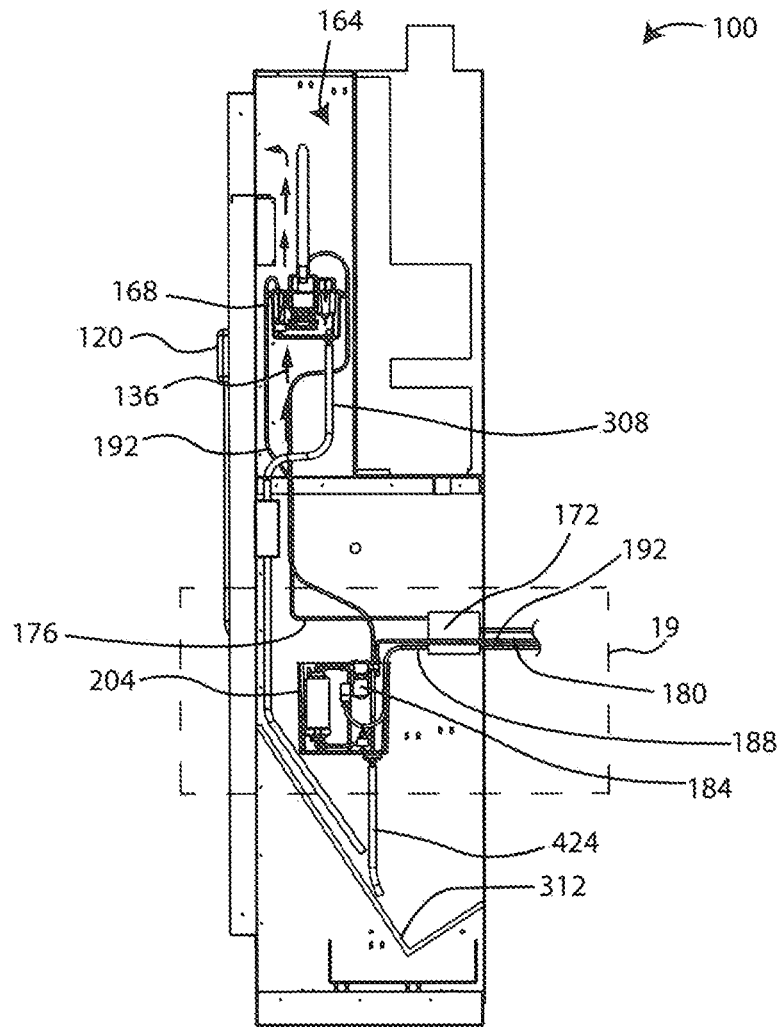

FIG. 5

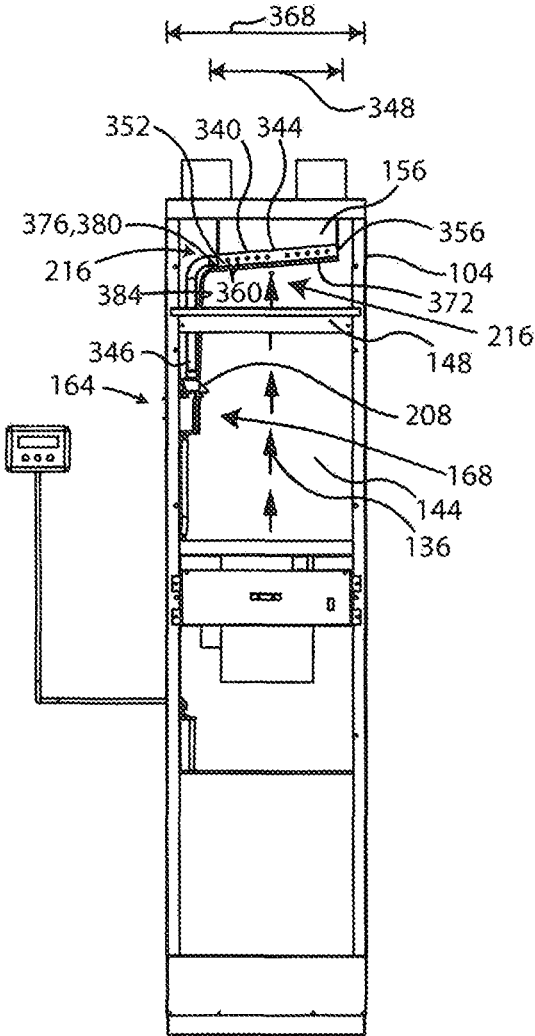

FIG. 6



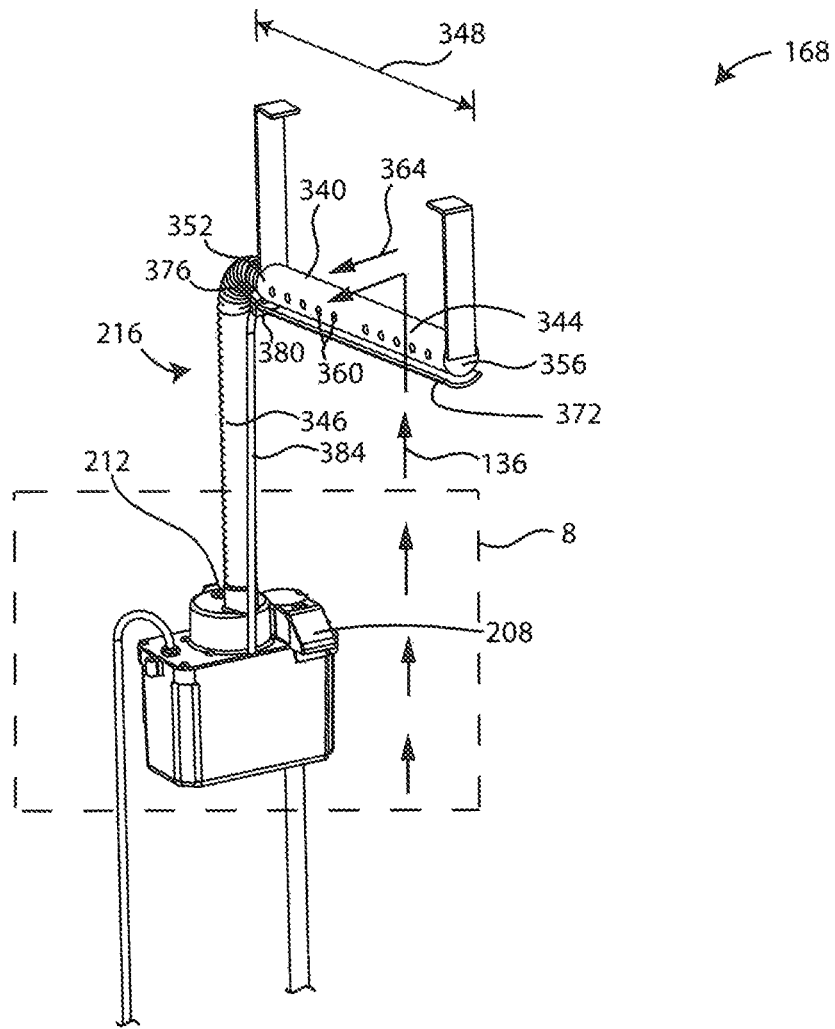

FIG. 7

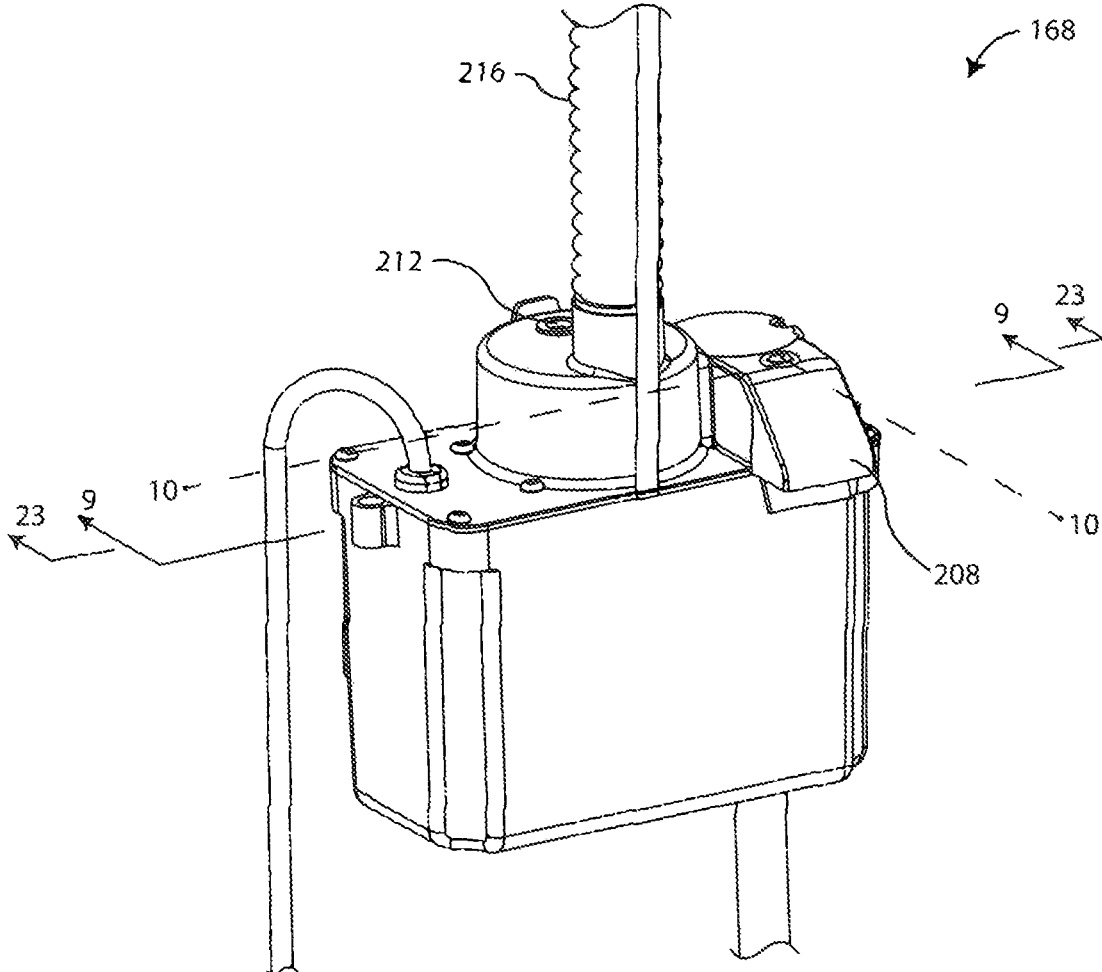

FIG. 8

168

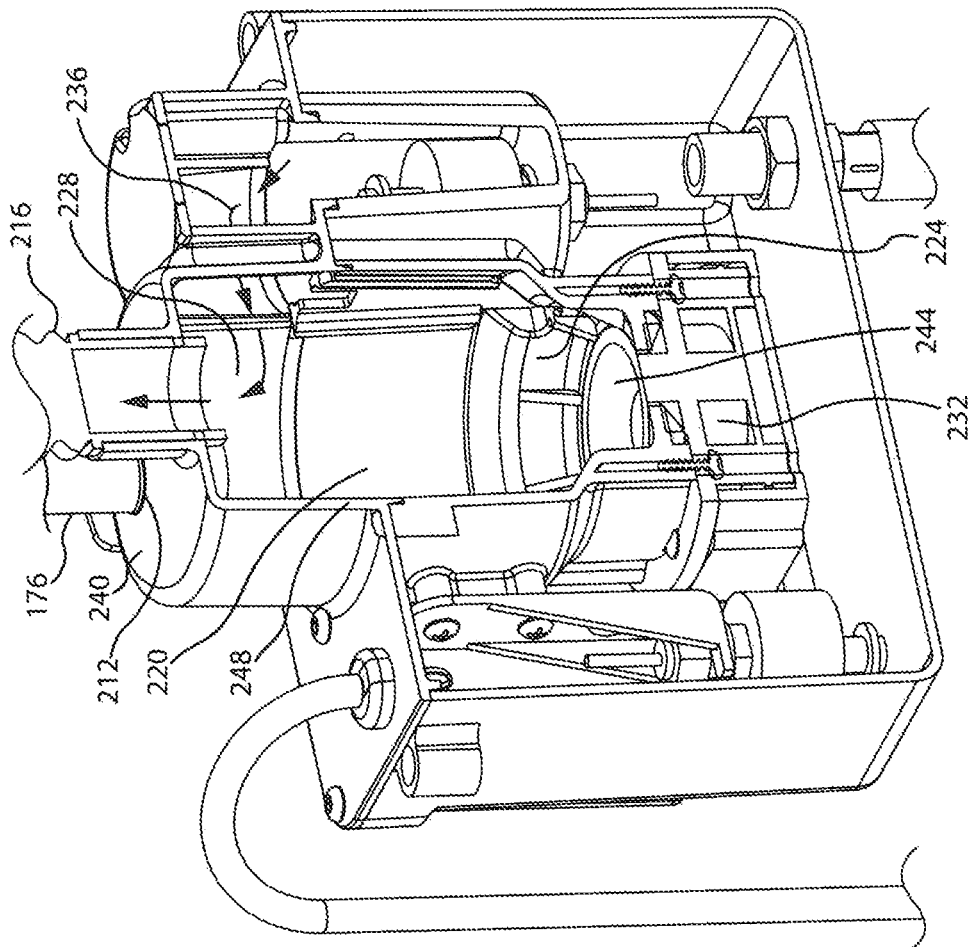

FIG. 9

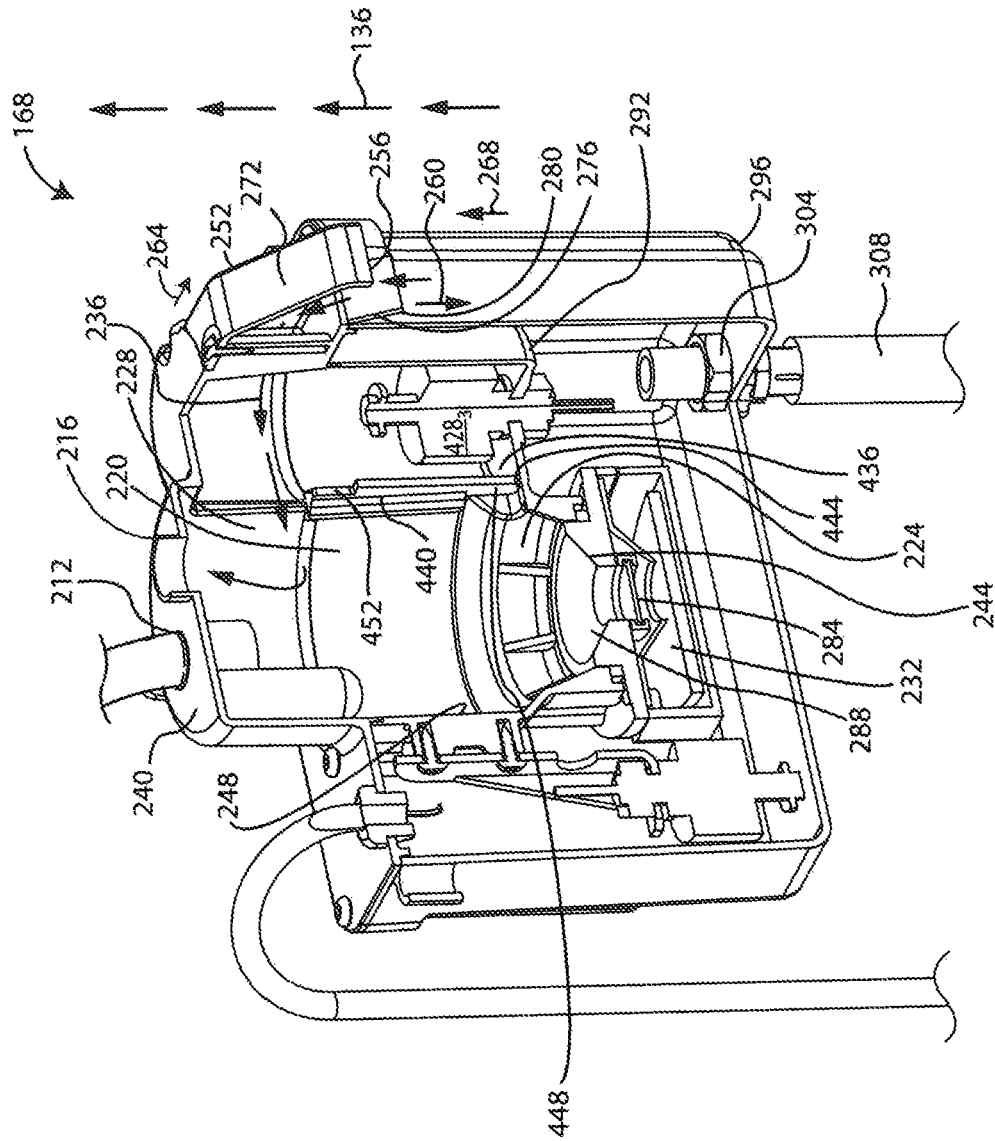

FIG. 10

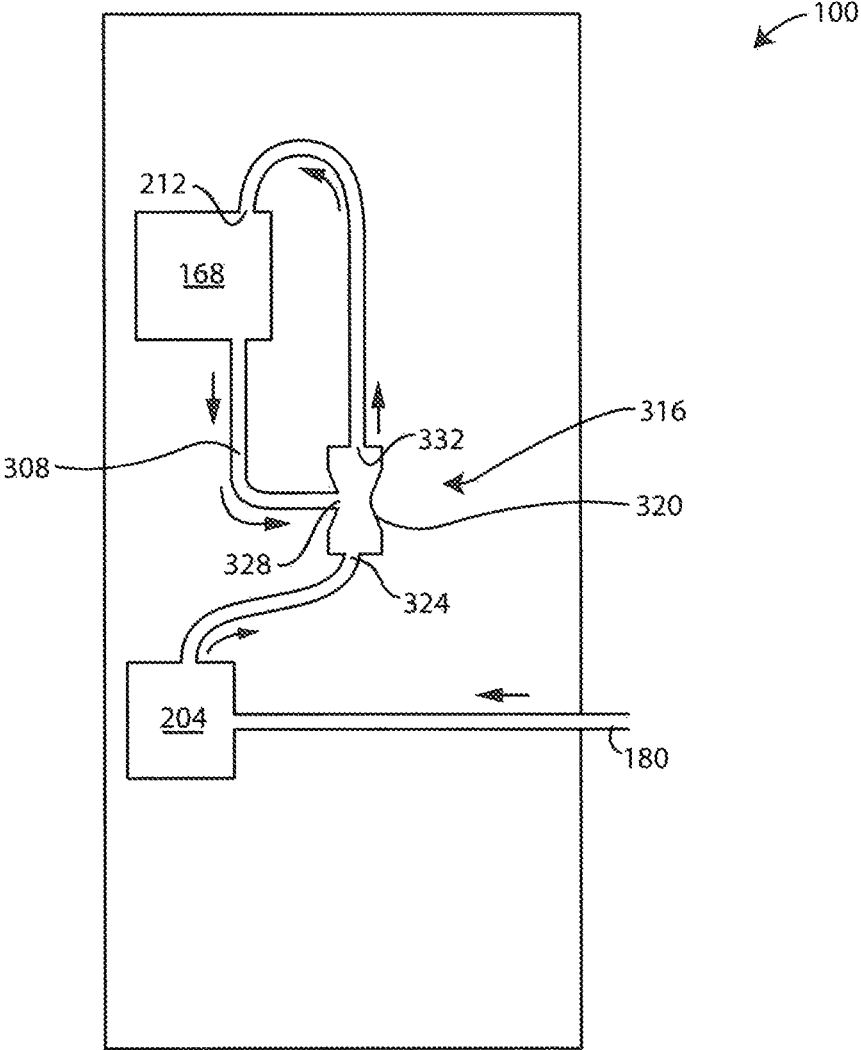

FIG. 11

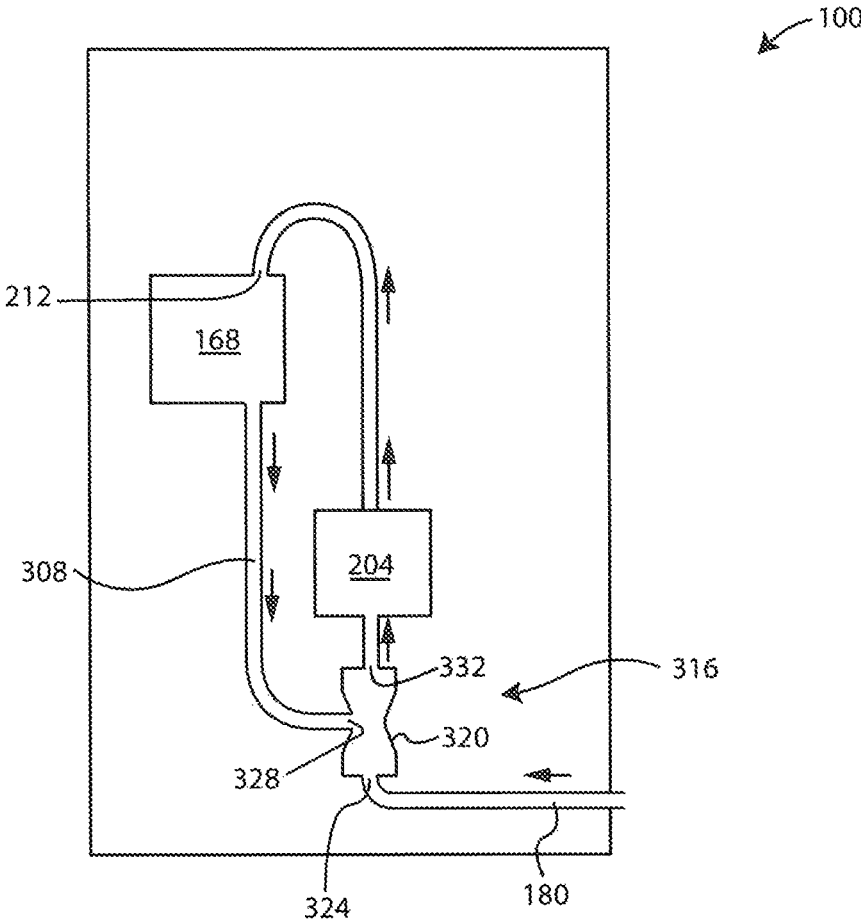

FIG. 12

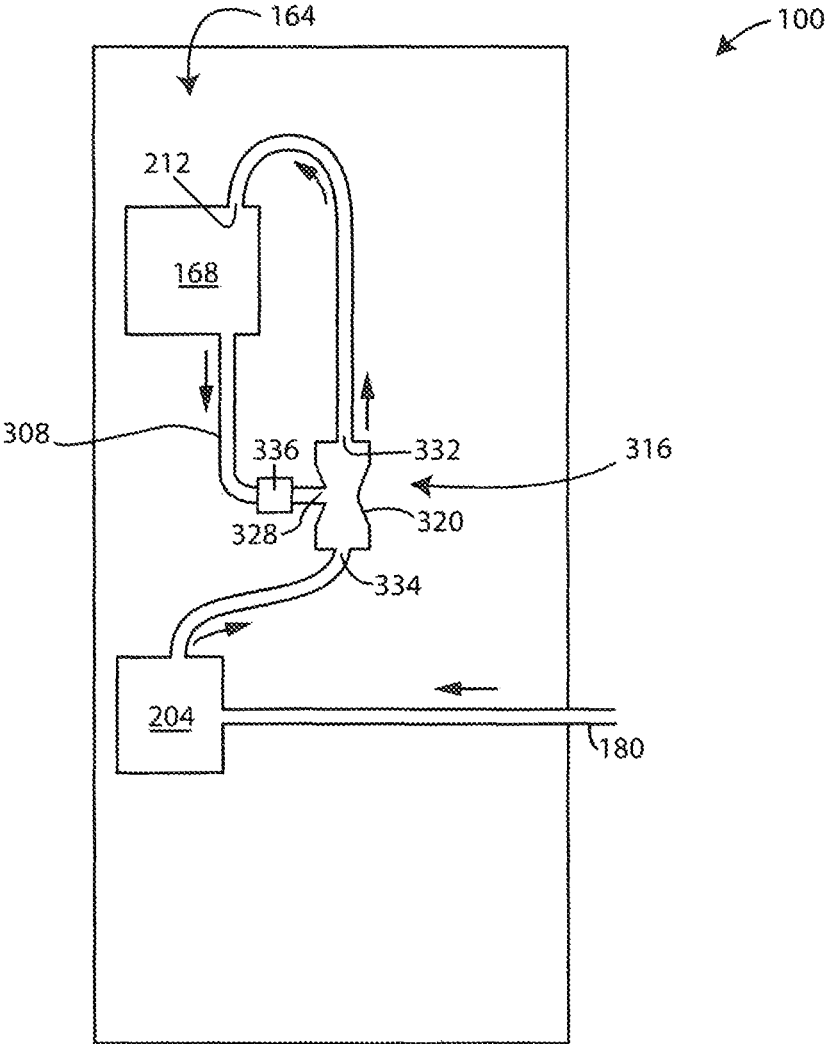

FIG. 13

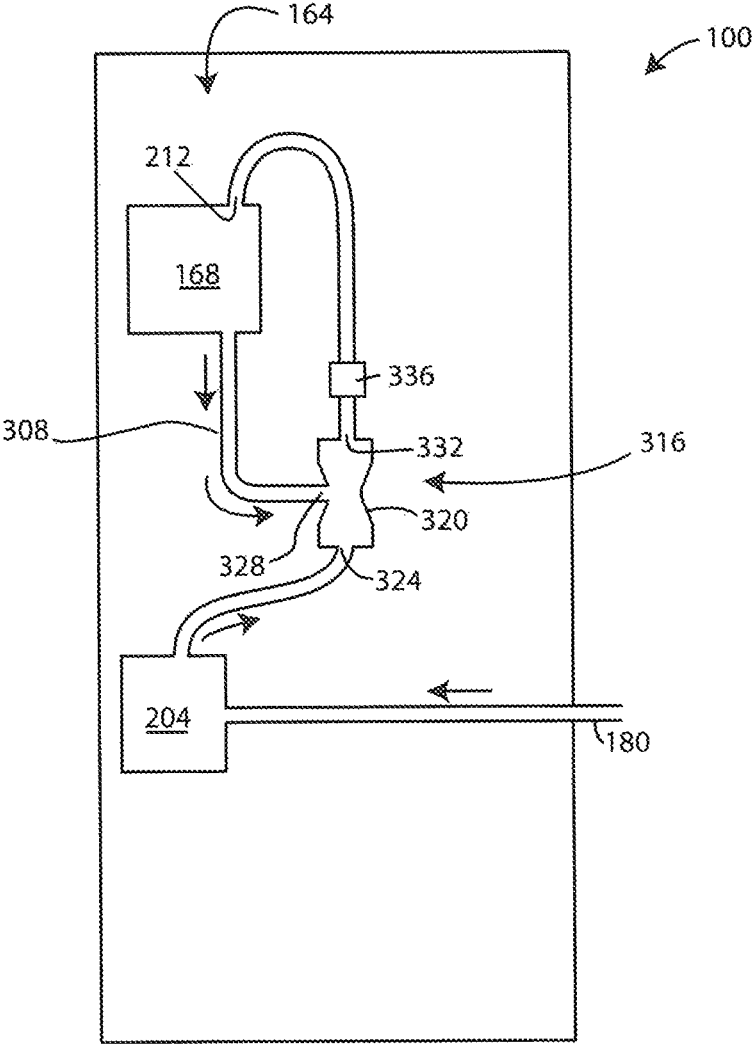

FIG. 14



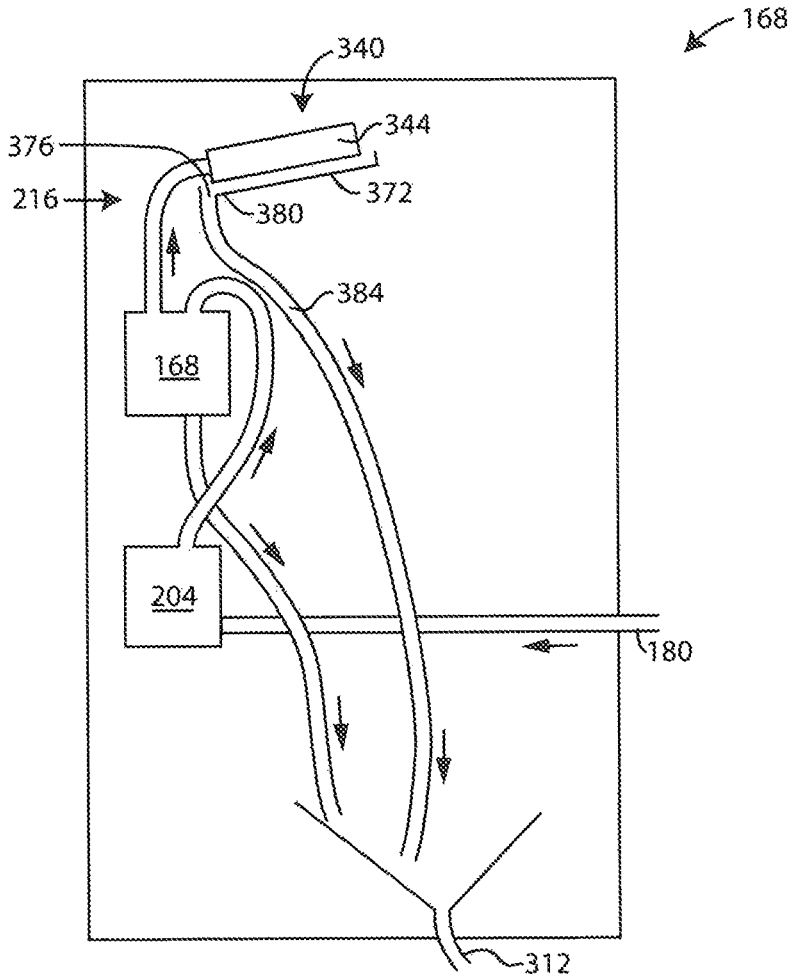

FIG. 15

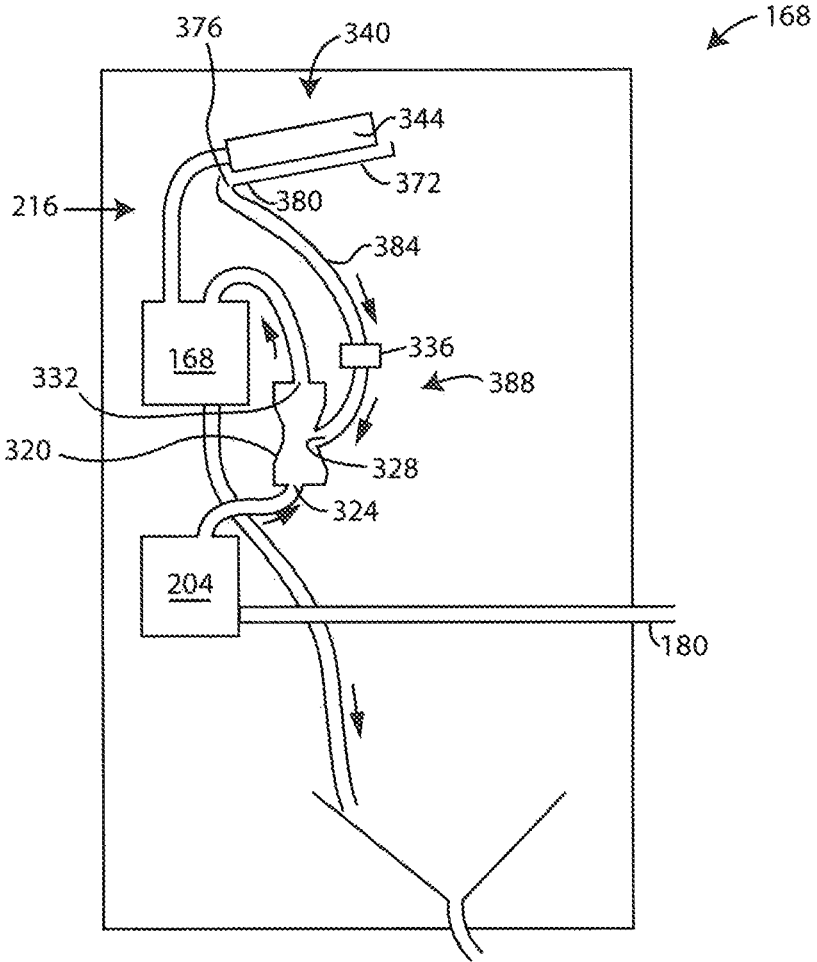

FIG. 16

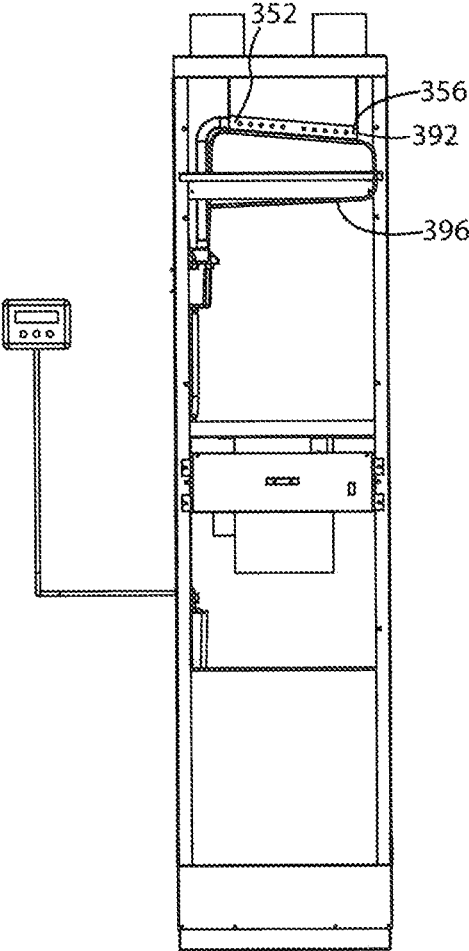

FIG. 17

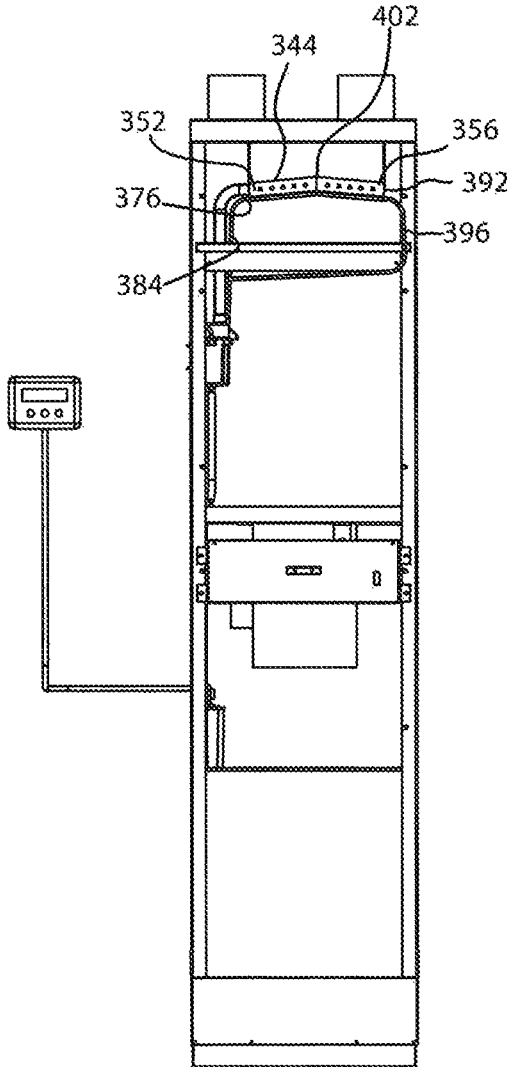

FIG. 18

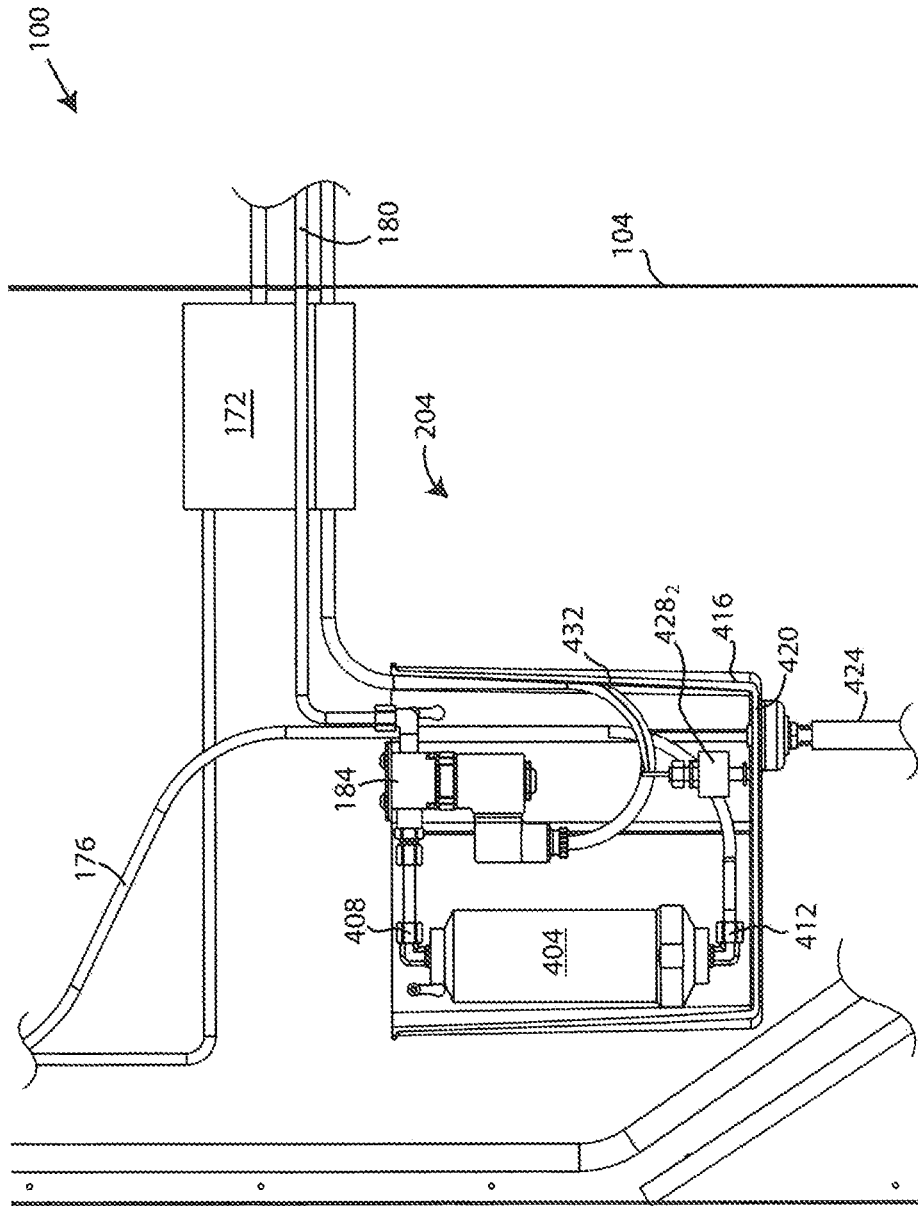

FIG. 19

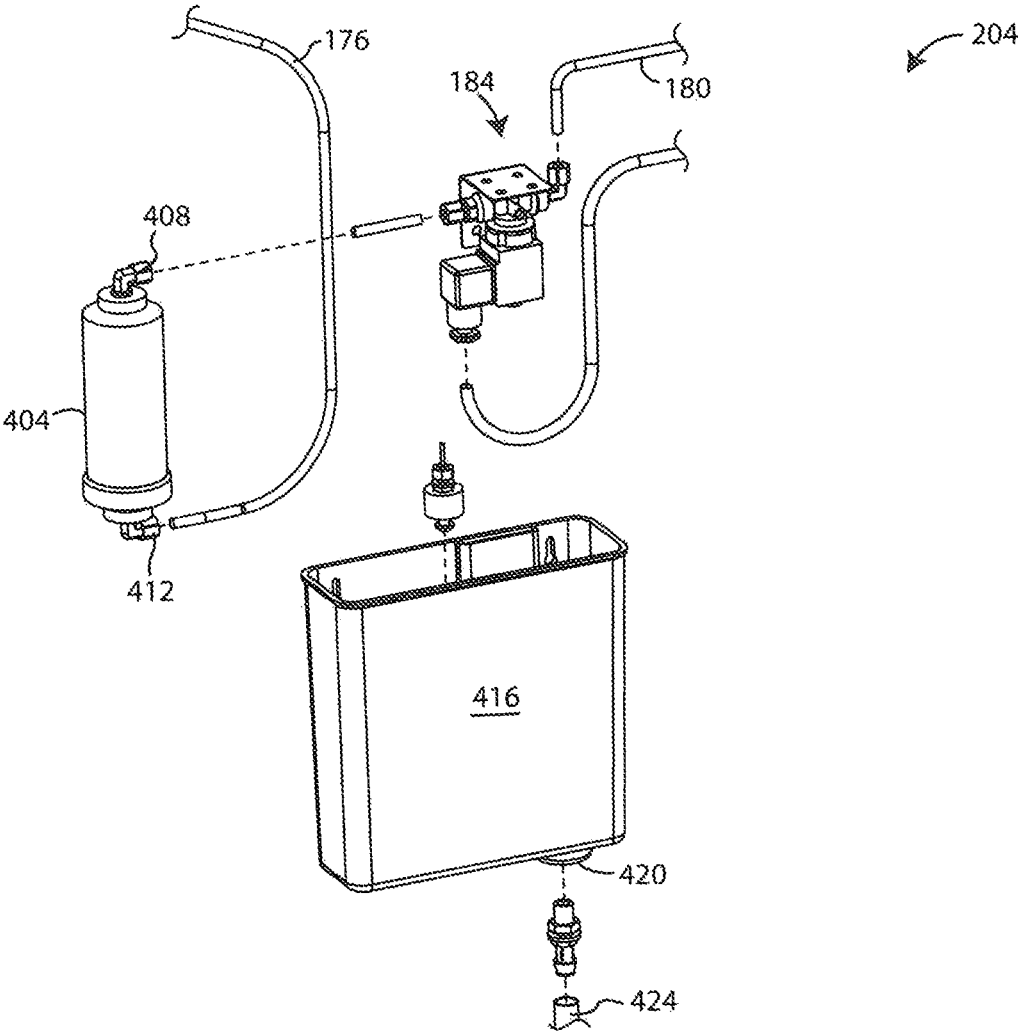

FIG. 20

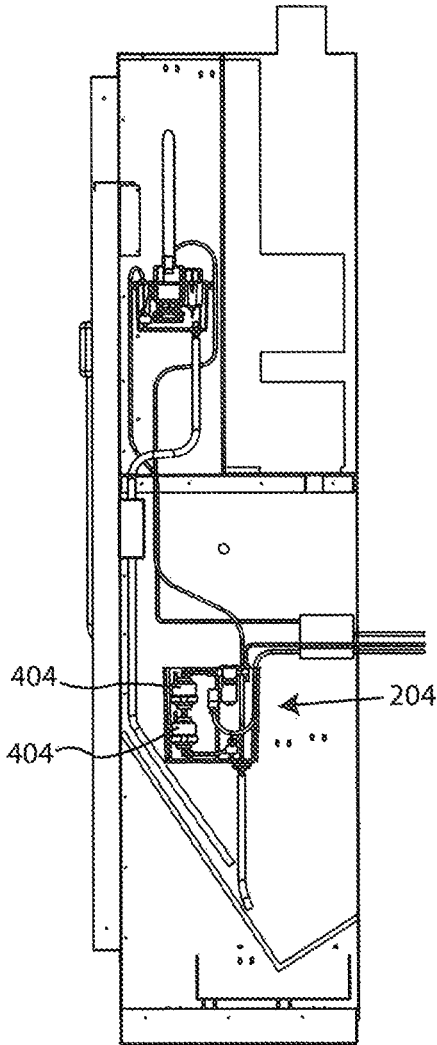

FIG. 21

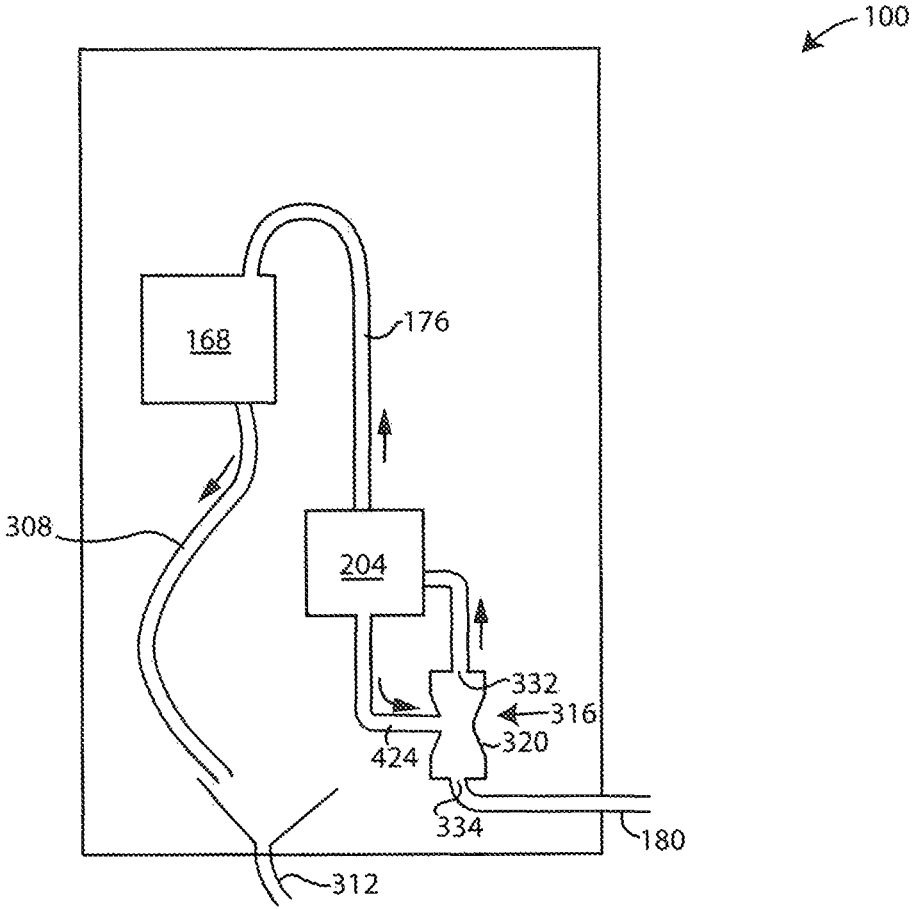

FIG. 22



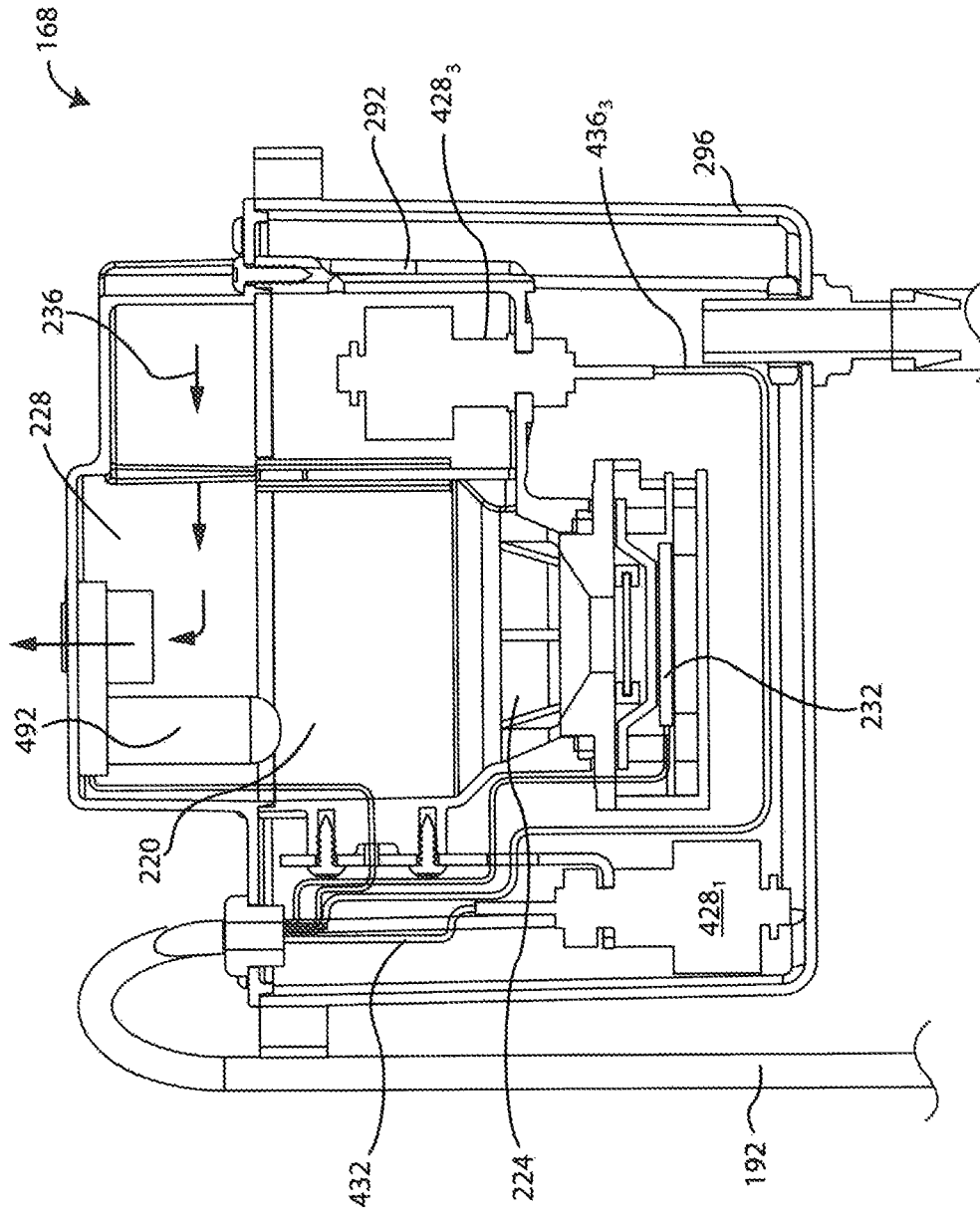

FIG. 23

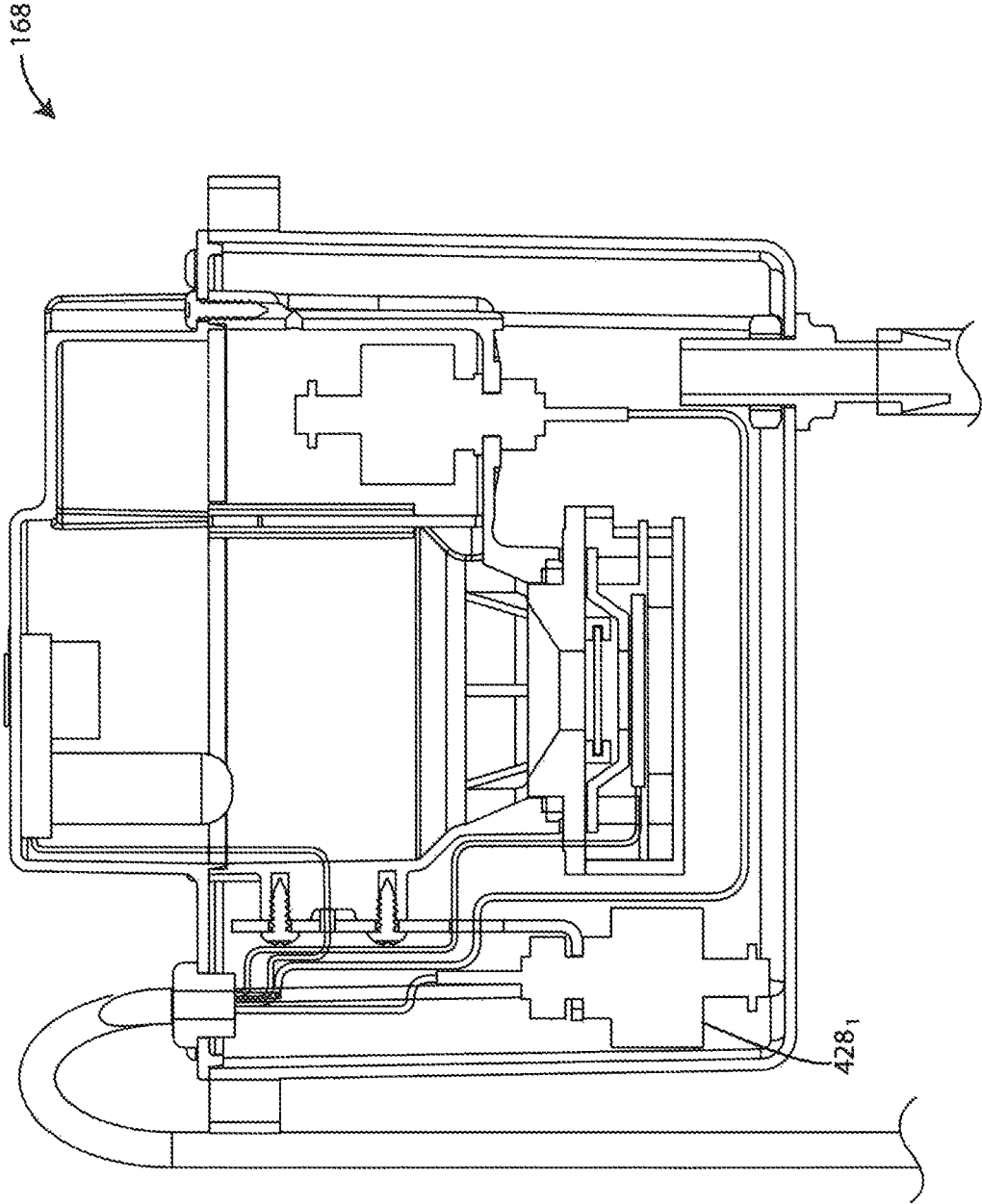

FIG. 24

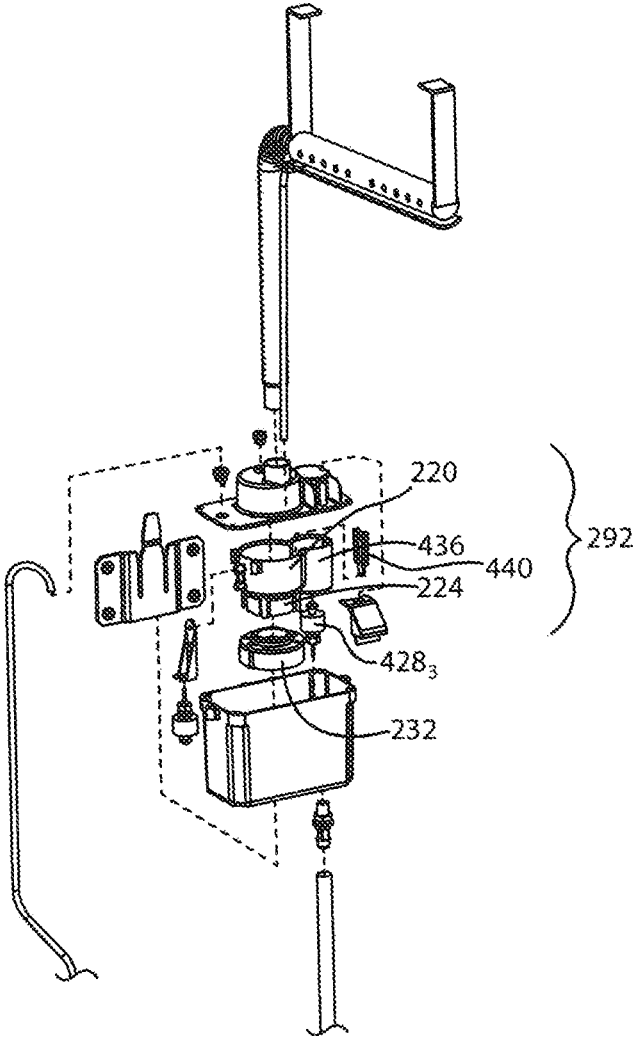

FIG. 25

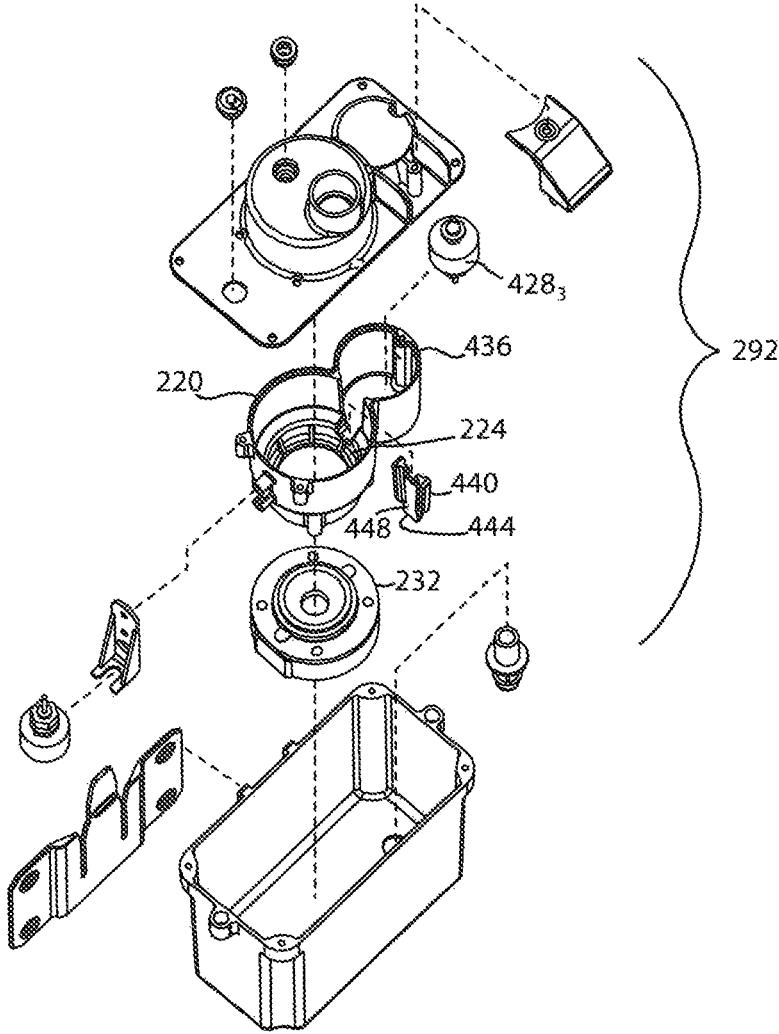

FIG. 26

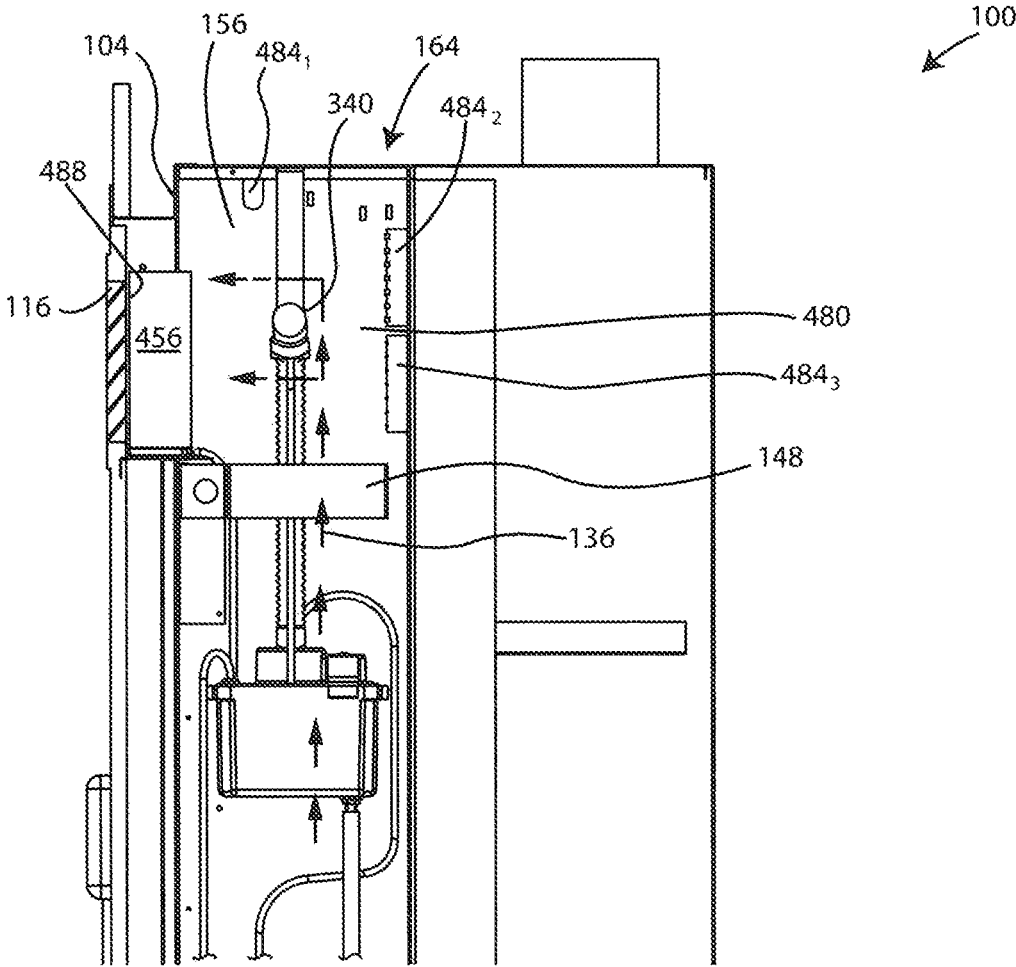

FIG. 27

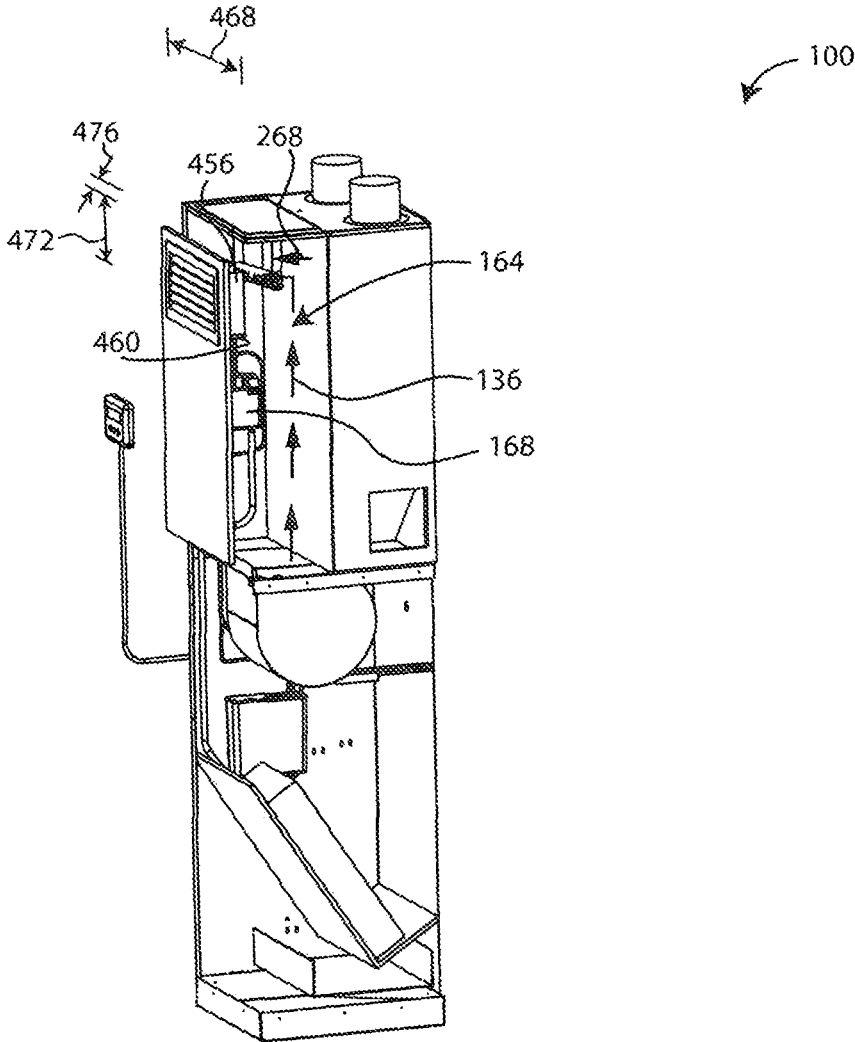

FIG. 28

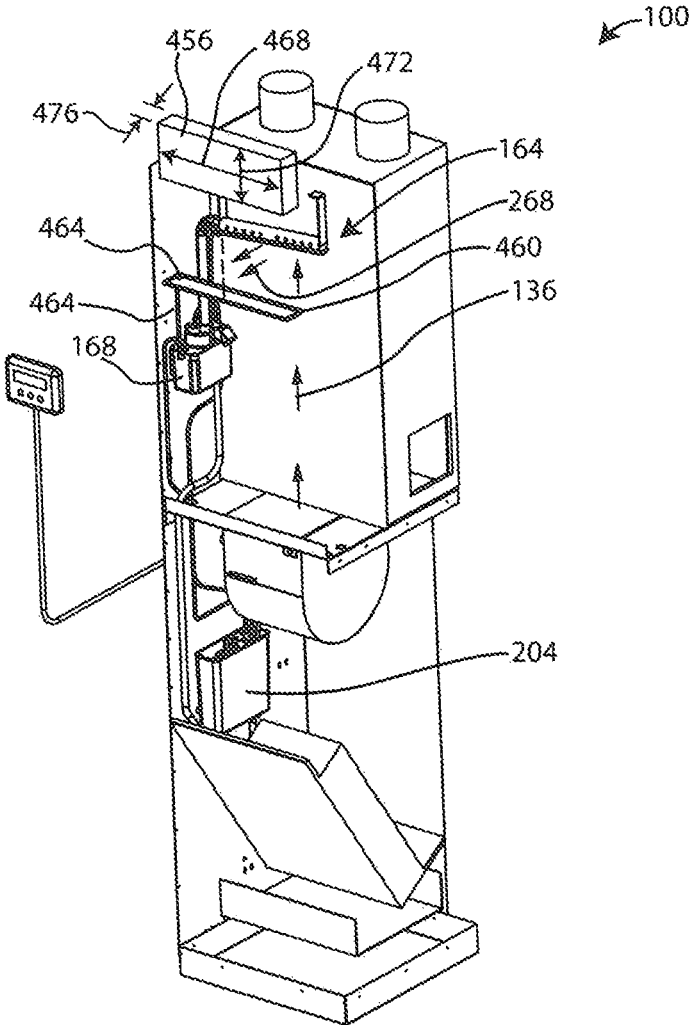

FIG. 29

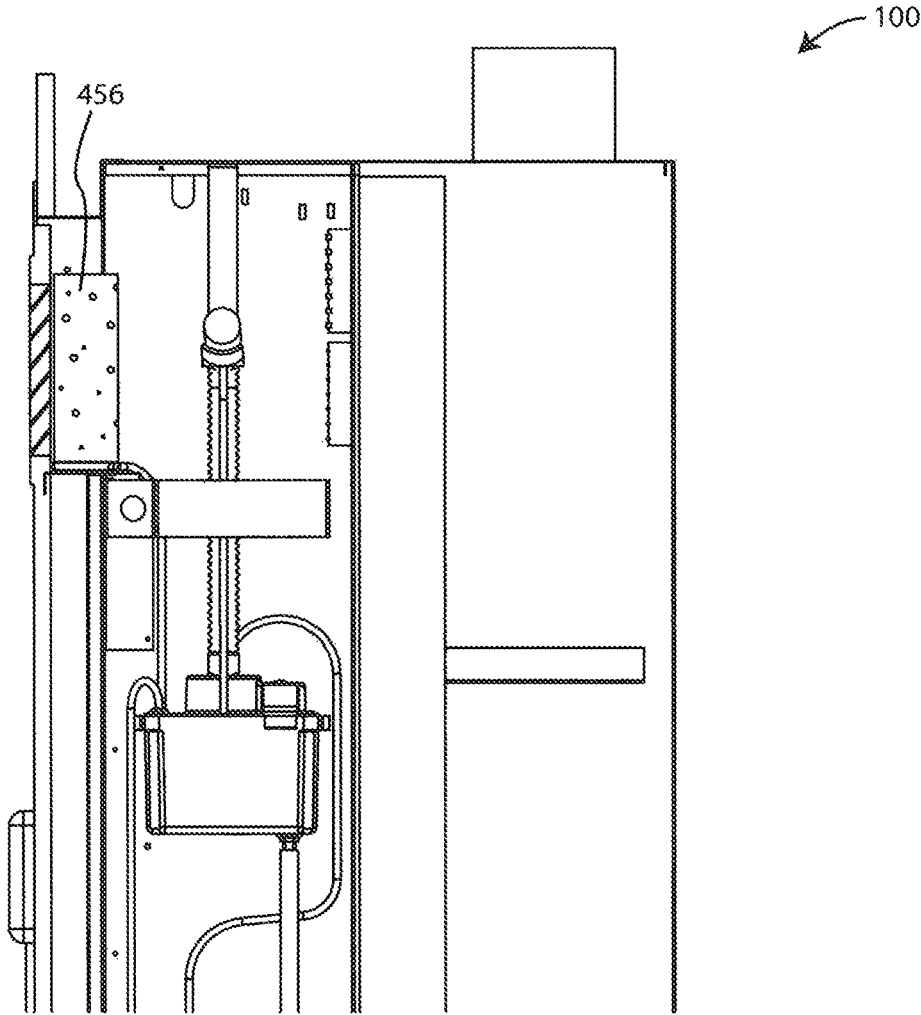

FIG. 30



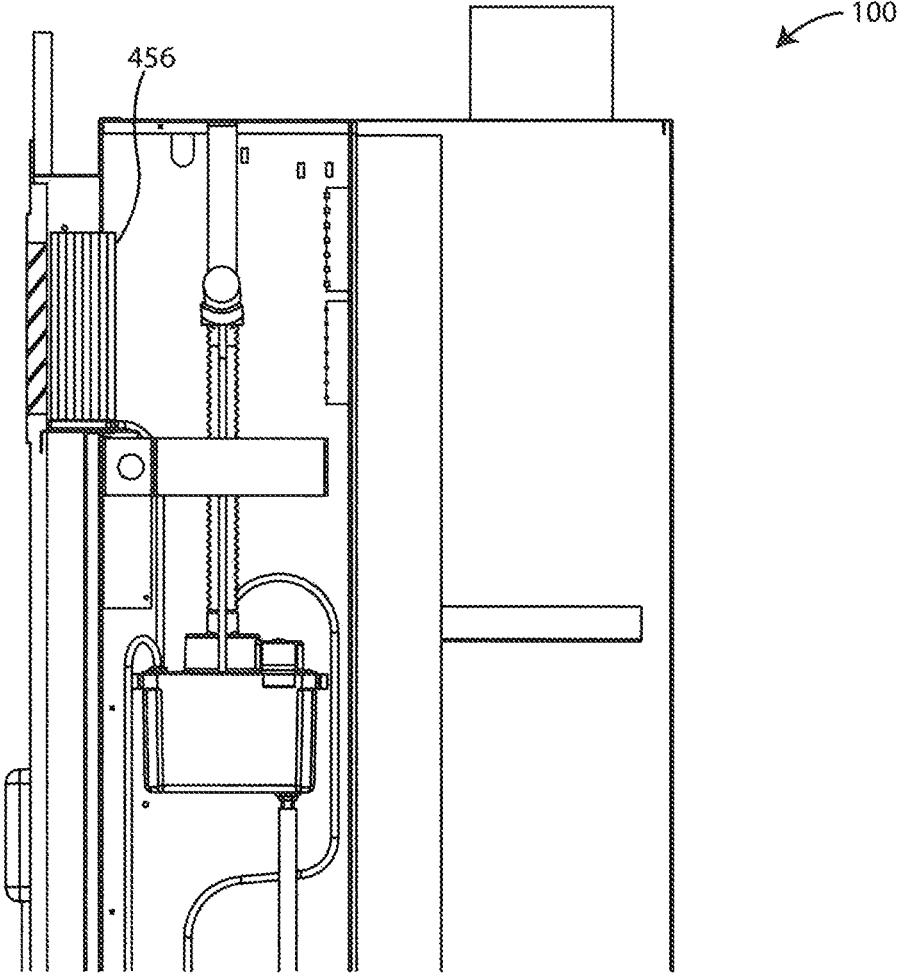

FIG. 31

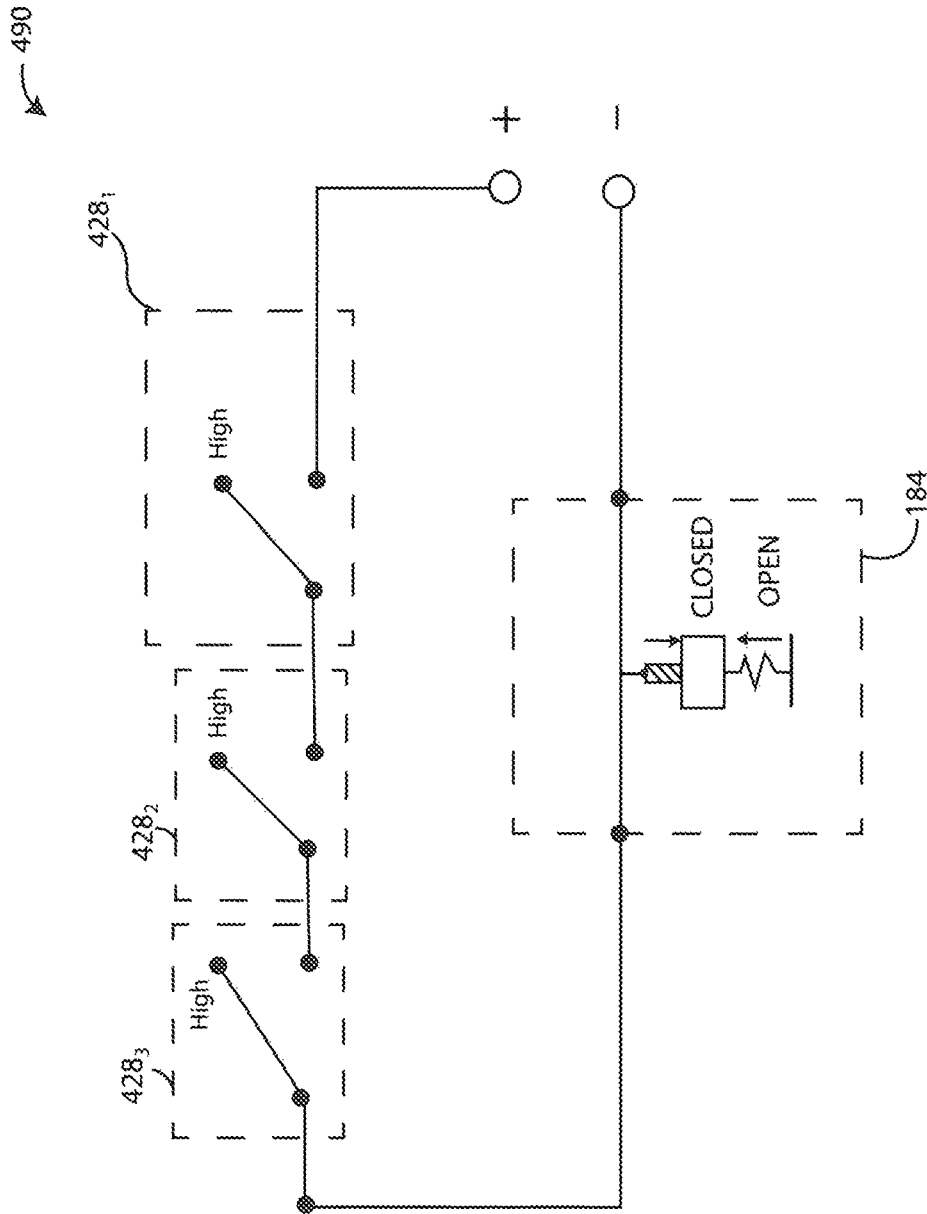

FIG. 32

1

# FAN COIL APPARATUS INCLUDING A HUMIDIFICATION UNIT AND A HUMIDIFICATION UNIT

## FIELD

This application relates to fan coil apparatus including a humidification unit and humidification units.

## BACKGROUND

A fan coil apparatus is a component part of many residential, commercial, and industrial heating, ventilation and air conditioning (HVAC) systems, which provide heated air to a room in which they are installed or to multiple rooms. A fan coils comprises a heating and/or cooling heat exchanger and a fan. Air to be heated or cooled is introduced into the heat exchanger and cooled or heated by ambient air that is to be exhausted from the room. The fan coil apparatus may be controlled automatically by a thermostat which may activate the fan coil apparatus as required to maintain a set air temperature in the room.

## SUMMARY

This summary is intended to introduce the reader to the more detailed description that follows and not to limit or define any claimed or as yet unclaimed invention. One or more inventions may reside in any combination or sub-combination of the elements or process steps disclosed in any part of this document including its claims and figures.

In accordance with one broad aspect of the teachings described herein, which may be used alone or in combination with any other aspect, there is provided a water recovery system for a fan coil assembly which is preferably located in the air exit plenum or passage of a fan coil assembly. The water recovery system comprises a member or members that retain water droplets, which may be micro water droplets and optionally collects some or substantially all or all of the droplets that are not evaporated by air passing through the fan coil assembly.

In accordance with this aspect, there is provided a fan coil apparatus comprising a humidification unit, the humidification unit comprising:

- (a) a humidification unit water droplet outlet;
- (b) an air permeable water retaining member positioned in an air flow path downstream from a heating zone and downstream from the humidification unit water droplet outlet;
- (c) a water impermeable container positioned below the air permeable water retaining member, the water impermeable container having a drain outlet; and,
- (d) a drain conduit connected in fluid flow communication with the drain outlet.

In some embodiments, the humidification unit may produce a water mist wherein the water mist enters an air flow stream via the humidification unit water droplet outlet.

In some embodiments, the humidification unit may comprise an ultrasonic humidifier such as a nebulizer.

In some embodiments, the fan coil apparatus may further comprise an air outlet plenum and the humidification unit is located in the plenum.

In some embodiments, the air permeable water retaining member may have a length in a direction transverse to a direction of air flow through the air permeable water retaining member and the humidification unit comprises a mist distributor generally extending in the transverse direction.

2

In some embodiments, the drain conduit may be connected in fluid flow communication with a drain.

In some embodiments, the humidification unit may further comprise a water mist production member and the drain conduit may be connected in fluid flow communication with the humidification unit at a location upstream of the water mist production member.

In some embodiments, the water mist production member may comprise an ultrasonic humidifier and a water filter upstream of the ultrasonic humidifier and the drain conduit may be connected in fluid flow communication with the humidification unit upstream of the water filter.

In some embodiments, the drain conduit may be connected in fluid flow communication with the humidification unit via a venturi.

In some embodiments, the location upstream of the water mist production member may be positioned below the water impermeable container whereby water drains from the water impermeable container through the drain conduit under the influence of gravity.

In some embodiments, the drain conduit may be connected in fluid flow communication with a water reservoir of the humidification unit.

In some embodiments, the air permeable water retaining member may be seated on the water impermeable container.

In some embodiments, the air permeable water retaining member may be removably receivable from the container.

In accordance with this aspect, there is also provided a humidification unit for a fan coil apparatus, the humidification unit comprising:

- (a) a humidification unit water droplet outlet;
- (b) an air permeable water retaining member positioned in an air flow path downstream from a heating zone and downstream from the humidification unit water droplet outlet;
- (c) a water impermeable container positioned below the air permeable water retaining member, the water impermeable container having a drain outlet; and,
- (d) a drain conduit connected in fluid flow communication with the drain outlet.

In some embodiments, the humidification unit may produce a water mist wherein the water mist enters an air flow stream via the humidification unit water droplet outlet.

In some embodiments, the humidification unit may comprise an ultrasonic humidifier such as a nebulizer.

In some embodiments, the air permeable water retaining member may have a length in a direction transverse to a direction of air flow through the air permeable water retaining member and the humidification unit comprises a mist distributor generally extending in the transverse direction.

In some embodiments, the humidification unit may further comprise a water mist production member and the drain conduit may be connected in fluid flow communication with the humidification unit at a location upstream of the water mist production member.

In some embodiments, the water mist production member may comprise an ultrasonic humidifier and a water filter upstream of the ultrasonic humidifier and the drain conduit may be connected in fluid flow communication with the humidification unit upstream of the water filter.

In some embodiments, the drain conduit may be connected in fluid flow communication with the humidification unit via a venturi.

In some embodiments, the location upstream of the water mist production member may be positioned below the water

3

impermeable container whereby water drains from the water impermeable container through the drain conduit under the influence of gravity.

In some embodiments, the drain conduit may be connected in fluid flow communication with a water reservoir of the humidification unit.

In accordance with a second aspect of this disclosure, which may be used alone or in combination with any other aspect, there is provided a mist distributor which is configured to distribute the water droplets, which are preferably micro water droplets such as those produced by an ultrasonic humidifier, across part or all of an air flow path and optionally to collect water droplets that are not entrained or evaporated into the air stream.

In accordance with this second aspect, there is provided a fan coil comprising a humidification unit, the humidification unit comprising:

- (a) a water mist distribution tube having a plurality of outlets;
- (b) a water impermeable container positioned below the water mist distribution tube, the water impermeable container having a drain outlet; and,
- (c) a drain conduit connected in fluid flow communication with the drain outlet.

In some embodiments, the humidification unit may produce a water mist wherein the water mist enters an air flow stream via the plurality of outlets.

In some embodiments, the humidification unit may comprise an ultrasonic humidifier such as a nebulizer.

In some embodiments, the water mist distribution tube may be positioned in an air flow conduit, the air flow conduit may have a length in a direction transverse to a direction of air flow through the air flow conduit and the water mist distribution tube may extend at least substantially along the length of the air flow conduit.

In some embodiments, the water mist distribution tube may extend generally transverse to the direction of air flow through the air flow conduit.

In some embodiments, the water mist distribution tube may be a longitudinally extending tube having first and second opposed ends wherein the water mist distribution tube may extend upwardly from the first end to the second end. In some embodiments, the first end may comprise a water mist inlet end and/or the second end may comprise a water mist inlet end.

In some embodiments, the water mist distribution tube may be a longitudinally extending tube having first and second opposed ends wherein a central portion of the water mist distribution tube may be elevated with respect to the first and second ends.

In some embodiments, the drain conduit may be connected in fluid flow communication with a drain.

In some embodiments, the humidification unit may further comprise a water mist production member and the drain conduit may be connected in fluid flow communication with the humidification unit at a location upstream of the water mist production member.

In some embodiments, the water mist production member may comprise an ultrasonic humidifier and a water filter upstream of the ultrasonic humidifier and the drain conduit may be connected in fluid flow communication with the humidification unit upstream of the water filter.

In some embodiments, the drain conduit may be connected in fluid flow communication with the humidification unit via a venturi.

In some embodiments, the location upstream of the water mist production member may be positioned below the water

4

impermeable container whereby water drains from the water impermeable container through the drain conduit under the influence of gravity.

In some embodiments, the drain conduit may be connected in fluid flow communication with a water reservoir of the humidification unit.

In accordance with this second aspect, there is also provided a humidification unit for a fan coil, the humidification unit comprising:

- (a) a water mist distribution tube having a plurality of outlets;
- (b) a water impermeable container positioned below the water mist distribution tube, the water impermeable container having a drain outlet; and,
- (c) a drain conduit connected in fluid flow communication with the drain outlet.

In some embodiments, the humidification unit may produce a water mist wherein the water mist enters an air flow stream via the plurality of outlets.

In some embodiments, the humidification unit may comprise an ultrasonic humidifier such as a nebulizer.

In some embodiments, the humidification unit may further comprise a water mist production member and the drain conduit may be connected in fluid flow communication with the humidification unit at a location upstream of the water mist production member.

In some embodiments, the water mist production member may comprise an ultrasonic humidifier and a water filter upstream of the ultrasonic humidifier and the drain conduit may be connected in fluid flow communication with the humidification unit upstream of the water filter.

In some embodiments, the drain conduit may be connected in fluid flow communication with the humidification unit via a venturi.

In some embodiments, the location upstream of the water mist production member may be positioned below the water impermeable container whereby water drains from the water impermeable container through the drain conduit under the influence of gravity.

In some embodiments, the drain conduit may be connected in fluid flow communication with a water reservoir of the humidification unit.

In accordance with a third aspect of this disclosure, which may be used alone or in combination with any other aspect, there is provided an air inlet for a humidification unit for a fan coil assembly which uses the blower of the fan coil to provide the air flow across a source of moisture, such as an ultrasonic humidification member. The inlet may be in the form of a scoop or channel that extends into an air flow path, preferably upstream of a heating unit, and guides the air flow into a chamber and across a source of moisture.

In accordance with this third aspect, there is provided a fan coil apparatus comprising a humidification unit, the humidification unit comprising:

- (a) a water mist production member including a chamber wherein, in operation, a water mist produced by the water mist production member is present in the chamber; and,
- (b) an air flow path extending from an air inlet to an air outlet and passing through the chamber, wherein air passing through the air flow path draws water mist from the chamber and out the air outlet, wherein the air inlet comprises a scoop positioned in a first portion of an air flow path of the fan coil apparatus.

In some embodiments, the humidification unit may comprise an ultrasonic humidifier such as a nebulizer.

5

In some embodiments, the ultrasonic humidifier may be provided in a water tank and the air outlet is provided in an upper portion of the water tank.

In some embodiments, the fan coil apparatus may further comprise a water reservoir upstream of the water tank.

In some embodiments, the fan coil apparatus may further comprise a water filter upstream of the water reservoir.

In some embodiments, the water filter may be selectively connectable in flow communication with a supply of water by an openable valve, wherein the valve is openable when a water level in the water reservoir is low.

In some embodiments, the water reservoir may be selectively connectable in flow communication with a supply of water by an openable valve, wherein the valve is openable when a water level in the water reservoir is low.

In some embodiments, the water reservoir may comprise a float switch that is operatively connectable to the openable valve.

In some embodiments, the water reservoir may be in flow communication with the water tank by gravity feed.

In some embodiments, the air outlet may comprise a plurality of outlets provided in a water mist distribution tube.

In some embodiments, the water mist distribution tube may be provided in a second portion of air flow path of the fan coil apparatus downstream of a location of the scoop, the second portion of air flow path of the fan coil apparatus may have a length in a direction transverse to a direction of air flow therethrough and the water mist distribution tube may extend at least substantially along the length of the second portion of the air flow path.

In some embodiments, the water mist distribution tube may extend generally transverse to the direction of air flow through the second portion.

In accordance with this third aspect, there is also provided a humidification unit for a fan coil apparatus, the humidification unit comprising:

- (a) a water mist production member including a chamber wherein, in operation, a water mist produced by the water mist production member is present in the chamber; and,
- (b) an air flow path extending from an air inlet to an air outlet and passing through the chamber, wherein air passing through the air flow path draws water mist from the chamber and out the air outlet, wherein the air inlet comprises a scoop positionable in a first portion of an air flow path of a fan coil apparatus.

In some embodiments, the humidification unit may comprise an ultrasonic humidifier such as a nebulizer.

In some embodiments, the ultrasonic humidifier may be provided in a water tank and the air outlet is provided in an upper portion of the water tank.

In some embodiments, the fan coil apparatus may further comprise a water reservoir upstream of the water tank.

In some embodiments, the fan coil apparatus may further comprise a water filter upstream of the water reservoir.

In some embodiments, the water filter may be selectively connectable in flow communication with a supply of water by an openable valve, wherein the valve is openable when a water level in the water reservoir is low.

In some embodiments, the water reservoir may be selectively connectable in flow communication with a supply of water by an openable valve, wherein the valve is openable when a water level in the water reservoir is low.

In some embodiments, the water reservoir may comprise a float switch that is operatively connectable to the openable valve.

6

In some embodiments, the water reservoir may be in flow communication with the water tank by gravity feed.

In accordance with a fourth aspect of this disclosure, which may be used alone or in combination with any other aspect, there is provided a safety control system which shuts off water flow to the humidification unit of a fan coil assembly and optionally, water flow to the fan coil assembly. The safety control system monitors the water level in one or more leak reservoirs and may shut off an inlet valve if a high water level condition occurs.

In accordance with this fourth aspect, there is provided a fan coil comprising a humidification unit, the humidification unit comprising:

- (a) an inner container comprising a water supply for a water mist production member and an inner container water level detector, the inner container water level detector sensing a high water level in the inner container when a water level in the inner container is at a high water level position;
- (b) an outer container comprising a reservoir and an outer container water level detector, wherein the outer container is positioned to receive water which leaks from the inner container, the outer container water level detector sensing a high water level in the outer container when a water level in the outer container is at a high water level position;
- (c) a water supply conduit connectable to a source of water and in fluid flow communication with the inner container; and,
- (d) a shut off valve provided in the water supply conduit, the shut off valve operable between an open position and a closed position,

wherein the shut off valve is in the closed position when the inner container water level detector senses a high water level in the inner container or when the outer container water level detector senses a high water level in the outer container.

In some embodiments, the inner container may be positioned to overlie at least a portion of an open interior of the outer container.

In some embodiments, the outer container may have an inner chamber and the inner container may be at least partially nested in the outer container.

In some embodiments, the inner container water level detector may also sense a low water level in the inner container when a water level in the inner container is at a low water level position and the shut off valve may be in the closed position when the outer container water level detector senses a high water level in the outer container and when the inner container water level detector senses a low water level in the inner container.

In some embodiments, the outer container water level detector may also sense a low water level in the outer container when a water level in the outer container is at a low water level position and the shut off valve may be in the closed position when the inner container water level detector senses a high water level in the inner container and when the outer container water level detector senses a low water level in the outer container.

In some embodiments, the shut off valve may comprise a solenoid.

In some embodiments, at least one of the water level detectors may comprise a float switch.

In some embodiments, the inner container water level detector and the outer container water level detector may each comprise a float switch.

In some embodiments, the outer container may further comprise a drain.

In some embodiments, the water supply of the inner container may comprise a water mist production member chamber and a water reservoir chamber wherein the inner container water level detector is provided in the water mist production member chamber.

In some embodiments, the fan coil may further comprise a separating wall provided between the water mist production member chamber and the water reservoir chamber and the water reservoir chamber may be in flow communication with the water mist production member chamber.

In some embodiments, a fluid flow port may be provided in a lower portion of the separating wall.

In some embodiments, the fluid flow port may be positioned above an upper end of the water mist production member.

In accordance with this fourth aspect, there is also provided a humidification unit for a fan coil, the humidification unit comprising:

- (a) an inner container comprising a water supply for a water mist production member and an inner container water level detector, the inner container water level detector sensing a high water level in the inner container when a water level in the inner container is at a high water level position;
- (b) an outer container comprising a reservoir and an outer container water level detector, wherein the outer container is positioned to receive water which leaks from the inner container, the outer container water level detector sensing a high water level in the outer container when a water level in the outer container is at a high water level position;
- (c) a water supply conduit connectable to a source of water and in fluid flow communication with the inner container; and,
- (d) a shut off valve provided in the water supply conduit, the shut off valve operable between an open position and a closed position,

wherein the shut off valve is in the closed position when the inner container water level detector senses a high water level in the inner container or when the outer container water level detector senses a high water level in the outer container.

In some embodiments, the inner container may be positioned to overlie at least a portion of an open interior of the outer container.

In some embodiments, the inner container water level detector may also sense a low water level in the inner container when a water level in the inner container is at a low water level position and the shut off valve may be in the closed position when the outer container water level detector senses a high water level in the outer container and when the inner container water level detector senses a low water level in the inner container.

In some embodiments, the outer container water level detector may also sense a low water level in the outer container when a water level in the outer container is at a low water level position and the shut off valve may be in the closed position when the inner container water level detector senses a high water level in the inner container and when the outer container water level detector senses a low water level in the outer container.

In some embodiments, at least one of the water level detectors may comprise a float switch.

In some embodiments, the water supply of the inner container may comprise a water mist production member chamber and a water reservoir chamber wherein the inner container water level detector is provided in the water mist production member chamber.

In some embodiments, the humidification unit may further comprise a separating wall provided between the water mist production member chamber and the water reservoir chamber and the water reservoir chamber is in flow communication with the water mist production member chamber.

In some embodiments, a fluid flow port may be provided in a lower portion of the separating wall.

In some embodiments, the fluid flow port may be positioned above an upper end of the water mist production member.

In accordance with a fifth aspect of this disclosure, which may be used alone or in combination with any other aspect, there is provided a leak reservoir system for a water filter for a humidifier. In accordance with this embodiment, a water recovery system comprises a member or members which collect some or substantially all or all of the water that may leak from a water filter assembly of a fan coil assembly.

In accordance with this fifth aspect, there is provided a fan coil comprising a humidification unit, the humidification unit comprising:

- (a) a water filter comprising an inlet connectable to a source of water and a filtered water outlet in flow communication with a downstream portion of the humidification unit;
- (b) a leak container comprising a reservoir and a leak container water level detector, wherein the leak container is positioned to receive water which leaks from the water filter or flow conduits leading to or from the water filter, the leak container water level detector sensing a high water level in the leak container when a water level in the leak container is at a high water level position; and,
- (c) a shut off valve provided in the water supply conduit, the shut off valve operable between an open position and a closed position,

wherein the shut off valve is in the closed position when the leak container water level detector senses a high water level in the leak container.

In some embodiments, the water filter may be positioned to overlie at least a portion of an open interior of the leak container.

In some embodiments, the leak container may have an inner chamber and the water filter may be at least partially nested in the outer container.

In some embodiments, the leak container water level detector may also sense a low water level in the leak container when a water level in the leak container is at a low water level position and the shut off valve may be in the open position when the leak container water level detector senses a low water level in the inner container.

In some embodiments, the shut off valve may comprise a solenoid.

In some embodiments, the water level detector may comprise a float switch.

In some embodiments, the leak container may further comprise a drain.

In some embodiments, the humidification unit may further comprise:

- (a) an inner container comprising a water supply for a water mist production member and an inner container water level detector, the inner container water level detector sensing a high water level in the inner container when a water level in the inner container is at a high water level position, wherein the water supply comprises the downstream portion of the humidification unit; and,

(b) an outer container comprising a reservoir and an outer container water level detector, wherein the outer container is positioned to receive water which leaks from the inner container, the outer container water level detector sensing a high water level in the outer container when a water level in the outer container is at a high water level position;

wherein the shut off valve is also in the closed position when the inner container water level detector senses a high water level in the inner container or when the outer container water level detector senses a high water level in the outer container.

In some embodiments:

- (a) the inner container water level detector may also sense a low water level in the inner container when a water level in the inner container is at a low water level position;
- (b) the leak container water level detector may also sense a low water level in the leak container when a water level in the leak container is at a low water level position; and,
- (c) the shut off valve may be in the closed position when the outer container water level detector senses a high water level in the outer container and when the inner container water level detector senses a low water level in the inner container and when the leak container water level detector senses a low water level in the leak container.

In some embodiments:

- (a) the outer container water level detector may also sense a low water level in the outer container when a water level in the outer container is at a low water level position;
- (b) the leak container water level detector may also sense a low water level in the leak container when a water level in the leak container is at a low water level position; and,
- (c) the shut off valve may be in the closed position when the inner container water level detector senses a high water level in the inner container and when the outer container water level detector senses a low water level in the outer container and when the leak container water level detector senses a low water level in the leak container.

In accordance with this fifth aspect, there may also be provided a humidification unit for a fan coil, the humidification unit comprising:

- (a) a water filter comprising an inlet connectable to a source of water and a filtered water outlet in flow communication with a downstream portion of the humidification unit;
- (b) a leak container comprising a reservoir and a leak container water level detector, wherein the leak container is positioned to receive water which leaks from the water filter or flow conduits leading to or from the water filter, the leak container water level detector senses a high water level in the leak container when a water level in the leak container is at a high water level position; and,
- (c) a shut off valve provided in the water supply conduit, the shut off valve operable between an open position and a closed position,

wherein the shut off valve is in the closed position when the leak container water level detector senses a high water level in the inner container.

In some embodiments, the water filter may be positioned to overlie at least a portion of an open interior of the leak container.

In some embodiments, the leak container may have an inner chamber and the water filter is at least partially nested in the outer container.

In some embodiments, the leak container water level detector may also sense a low water level in the leak container when a water level in the leak container is at a low water level position and the shut off valve may be in the open position when the leak container water level detector senses a low water level in the inner container.

In some embodiments, the shut off valve may comprise a solenoid.

In some embodiments, the water level detector may comprise a float switch.

In some embodiments, the leak container may further comprise a drain.

In some embodiments, the humidification unit may further comprise:

- (a) an inner container comprising a water supply for a water mist production member and an inner container water level detector, the inner container water level detector senses a high water level in the inner container when a water level in the inner container is at a high water level position, wherein the water supply comprises the downstream portion of the humidification unit; and,

- (b) an outer container comprising a reservoir and an outer container water level detector, wherein the outer container is positioned to receive water which leaks from the inner container, the outer container water level detector senses a high water level in the outer container when a water level in the outer container is at a high water level position;

wherein the shut off valve is also in the closed position when the inner container water level detector senses a high water level in the inner container or when the outer container water level detector senses a high water level in the outer container.

In some embodiments:

- (a) the inner container water level detector may also sense a low water level in the inner container when a water level in the inner container is at a low water level position;
- (b) the leak container water level detector may also sense a low water level in the leak container when a water level in the leak container is at a low water level position; and,
- (c) the shut off valve may be in the closed position when the outer container water level detector senses a high water level in the outer container and when the inner container water level detector senses a low water level in the inner container and when the leak container water level detector senses a low water level in the leak container.

In some embodiments:

- (a) the outer container water level detector may also sense a low water level in the outer container when a water level in the outer container is at a low water level position;
- (b) the leak container water level detector may also sense a low water level in the leak container when a water level in the leak container is at a low water level position; and,
- (c) the shut off valve may be in the closed position when the inner container water level detector senses a high

11

water level in the inner container and when the outer container water level detector senses a low water level in the outer container and when the leak container water level detector senses a low water level in the leak container.

In accordance with a sixth aspect of this disclosure, which may be used alone or in combination with any other aspect, there is provided a humidifier treatment system to at least partially sterilize and preferably substantially sterilize or sterilize part or all of the humidification system.

In accordance with this sixth aspect, there is provided a fan coil apparatus comprising:

- (a) an air flow path extending from a heating zone to a fan coil air outlet and including a humidification section;
- (b) a humidification unit comprising a humidification unit water droplet outlet and an air permeable water retaining member, wherein the air permeable water retaining member and the humidification unit water droplet outlet are provided in the humidification section and the air permeable water retaining member is positioned downstream from the humidification unit water droplet outlet; and,
- (c) a treatment applicator providing a disinfecting agent upstream from an air outlet of the humidification section.

In some embodiments, the disinfecting agent may comprise one or more of ozone, UV light and hydrogen peroxide.

In some embodiments, the disinfecting agent may comprise ozone and the fan coil further may comprise an ozone destructor material positioned upstream from an air outlet of the fan coil.

In some embodiments, the humidification unit may be located in an air exit plenum of the fan coil.

In some embodiments, the disinfecting agent may be provided in the air exit plenum.

In some embodiments, the disinfecting agent may comprise one or more of ozone and hydrogen peroxide and the disinfecting agent may be introduced into the air exit plenum.

In some embodiments, the disinfecting agent may comprise ozone and the fan coil may further comprise an ozone destructor material positioned downstream from the air permeable water retaining member.

In some embodiments, the disinfecting agent may comprise a UV light source and the UV light source may be located in the air exit plenum.

In accordance with this sixth embodiment, there is also provided a humidification unit for a fan coil apparatus, the humidification unit comprising:

- (a) a humidification unit water droplet outlet;
- (b) an air permeable water retaining member positioned downstream from the humidification unit water droplet outlet; and,
- (c) a treatment applicator providing a disinfecting agent upstream from the air permeable water retaining member.

In some embodiments, the disinfecting agent may comprise one or more of ozone, UV light and hydrogen peroxide.

In some embodiments, the disinfecting agent may comprise ozone and the humidification unit may further comprise an ozone destructor material positioned upstream from an air outlet of the fan coil.

In some embodiments, the disinfecting agent may comprise one or more of ozone and hydrogen peroxide and the disinfecting agent may be introduced into the humidification unit upstream from the air permeable water retaining member.

12

In some embodiments, the disinfecting agent may comprise ozone and the humidification unit may further comprise an ozone destructor material positioned downstream from the air permeable water retaining member.

14. In some embodiments, the disinfecting agent may comprise a UV light source and the UV light source may be located between the humidification unit water droplet outlet and the air permeable water retaining member.

#### BRIEF DESCRIPTION OF THE SEVERAL VIEWS OF THE DRAWINGS

The drawings included herewith are for illustrating various examples of articles, methods, and apparatuses of the teaching of the present specification and are not intended to limit the scope of what is taught in any way.

FIG. 1 is a front perspective view of a fan coil apparatus in accordance with an embodiment;

FIG. 2 is a rear perspective view of the fan coil apparatus of FIG. 1;

FIG. 3 is a front perspective view of the fan coil apparatus of FIG. 1 with its front face removed;

FIG. 4 is a side perspective view of the fan coil apparatus of FIG. 1 with its front face removed;

FIG. 5 is a cross-sectional view taken along line 5-5 in FIG. 1;

FIG. 6 is a front elevation view of the fan coil apparatus of FIG. 1 with its front face removed;

FIG. 7 is a perspective view of a misting portion of a humidification unit;

FIG. 8 is an enlargement of region 8 in FIG. 7;

FIG. 9 is a perspective view of the misting portion sectioned along line 9-9 in FIG. 8;

FIG. 10 is a perspective view of the missing portion sectioned along line 10-10 in FIG. 8;

FIG. 11 is a schematic drawing of a fan coil apparatus in accordance with another embodiment;

FIG. 12 is a schematic drawing of a fan coil apparatus in accordance with another embodiment;

FIG. 13 is a schematic drawing of a fan coil apparatus in accordance with another embodiment;

FIG. 14 is a schematic drawing of a fan coil apparatus in accordance with another embodiment;

FIG. 15 is a schematic drawing of a fan coil apparatus in accordance with another embodiment;

FIG. 16 is a schematic drawing of a fan coil apparatus in accordance with another embodiment;

FIG. 17 is a front elevation view of a fan coil apparatus with its front face removed in accordance with another embodiment;

FIG. 18 is a front elevation view of a fan coil apparatus with its front face removed in accordance with another embodiment;

FIG. 19 is an enlarged view of region 19-19 in FIG. 5;

FIG. 20 is an exploded view of a filter portion of the humidification unit;

FIG. 21 is a cross-sectional view taken along line 5-5 in FIG. 1 in accordance with another embodiment;

FIG. 22 is a schematic drawing of a fan coil apparatus in accordance with another embodiment;

FIG. 23 is a cross-sectional view taken along line 23-23 in FIG. 8 with a leak water level detector sensing a lower water level;

FIG. 24 is a cross-sectional view taken along line 23-23 in FIG. 8 with the leak water level detector sensing a high water level;

FIG. 25 is an exploded view of the misting portion;



FIG. 26 is another exploded view of the misting portion;  
FIG. 27 is a cross-sectional view taken along line 27-27  
in FIG. 1;

FIG. 28 is a perspective view of the fan coil apparatus of  
FIG. 1 with part of its housing removed;

FIG. 29 is a perspective view of the fan coil apparatus of  
FIG. 1, with an air permeable water retaining member in an  
exploded position, and an air heating device removed;

FIG. 30 is a cross-sectional view taken along line 27-27  
in FIG. 1 in accordance with another embodiment; and,

FIG. 31 is a cross-sectional view taken along line 27-27  
in FIG. 1 in accordance with another embodiment.

FIG. 32 is a schematic drawing of a power circuit in  
accordance with another embodiment.

#### DESCRIPTION OF VARIOUS EMBODIMENTS

Numerous embodiments are described in this application,  
and are presented for illustrative purposes only. The  
described embodiments are not intended to be limiting in  
any sense. The invention is widely applicable to numerous  
embodiments, as is readily apparent from the disclosure  
herein. Those skilled in the art will recognize that the present  
invention may be practiced with modification and alteration  
without departing from the teachings disclosed herein. Although  
particular features of the present invention may be  
described with reference to one or more particular embodi-  
ments or figures, it should be understood that such features  
are not limited to usage in the one or more particular  
embodiments or figures with reference to which they are  
described.

The terms “an embodiment,” “embodiment,” “embodi-  
ments,” “the embodiment,” “the embodiments,” “one or  
more embodiments,” “some embodiments,” and “one  
embodiment” mean “one or more (but not all) embodiments  
of the present invention(s),” unless expressly specified oth-  
erwise.

The terms “including,” “comprising” and variations  
thereof mean “including but not limited to,” unless expressly  
specified otherwise. A listing of items does not imply that  
any or all of the items are mutually exclusive, unless  
expressly specified otherwise. The terms “a,” “an” and “the”  
mean “one or more,” unless expressly specified otherwise.

As used herein and in the claims, two or more parts are  
said to be “coupled”, “connected”, “attached”, or “fastened”  
where the parts are joined or operate together either directly  
or indirectly (i.e., through one or more intermediate parts),  
so long as a link occurs. As used herein and in the claims,  
two or more parts are said to be “directly coupled”, “directly  
connected”, “directly attached”, or “directly fastened”  
where the parts are connected in physical contact with each  
other. As used herein, two or more parts are said to be  
“rigidly coupled”, “rigidly connected”, “rigidly attached”, or  
“rigidly fastened” where the parts are coupled so as to move  
as one while maintaining a constant orientation relative to  
each other. None of the terms “coupled”, “connected”,  
“attached”, and “fastened” distinguish the manner in which  
two or more parts are joined together.

As used herein and in the claims, a first element is said to  
be “received” in a second element where at least a portion  
of the first element is received in the second element unless  
specifically stated otherwise.

#### Structure of a Fan Coil Apparatus

The following is a general description of a fan coil having  
a humidification unit and other features set out herein.

FIGS. 1 and 2 show a fan coil apparatus 100, in accor-  
dance with an embodiment. In the illustrated example, fan

coil apparatus 100 includes a housing 104 including a front  
face 108 defining an air inlet 112 and an air outlet 116. The  
fan coil apparatus 100 is operable to receive air from air inlet  
112, heat or cool the air introduced from inlet 112 and, as  
selected, humidify the air, and discharge the treated air  
through air outlet 116 into a room.

The example shown includes a housing 104 that is sub-  
stantially cuboid (i.e. box-shaped). An advantage of this  
design is that it provides an efficient and convenient form  
factor for applications where the fan coil apparatus 100 is  
recessed into a flat wall. However, in alternative embodi-  
ments, fan coil housing 104 can have any size and shape best  
suited for the intended application.

In the example shown, the fan coil inlet and outlet 112 and  
116 are formed in the front face 108 of the fan coil housing  
104. This design provides an efficient self-contained appa-  
ratus 100 that can be easily accommodated into a room  
design. However, in alternative embodiments, the fan coil  
inlet 112, the fan coil outlet 116, or both may be located  
remotely from the fan coil housing 104. For example, the fan  
coil outlet 116 may be fluidly connected to the fan coil  
housing 104 by one or more airflow conduits to allow the fan  
coil apparatus 100 to service one or more rooms remote from  
the fan coil apparatus 100 (e.g., via ducting built into a wall  
or ceiling of a building). In some embodiments, fan coil  
apparatus 100 may include a plurality of fan coil air inlets  
112, a plurality of fan coil air outlets 116, or a plurality of  
fan coil air inlets 112 and a plurality of fan coil air outlets  
116. For example, fan coil apparatus 100 may include a  
plurality of fan coil air outlets 116 directed to different  
rooms. This allows one fan coil apparatus 100 to service  
several rooms.

Still referring to FIGS. 1 and 2, an air regulating device  
120 is shown connected to fan coil apparatus 100. The air  
regulating device 120 may operate as a thermostat and/or a  
hygrostat, capable of sensing air temperature and/or air  
humidity, and signaling the fan coil apparatus 100 to gener-  
ate heated, cooled and/or humidified air in order to main-  
tain the room air at a set temperature and/or humidity. For  
example, the air regulating device 120 may be programmed  
to maintain the room air at 21° C. and 40% relative humidity  
for comfortable human occupancy. Air regulating device  
120 can be any thermostat and/or hygrostat device known in  
the art. In the illustrated embodiment, air regulating device  
120 includes inputs 124 for user interaction (e.g. buttons to  
enter a set air temperature and relative humidity), and an  
optional display 128 (e.g. to display the current air tempera-  
ture and relative humidity).

Reference is now made to FIGS. 3-4 which shows fan coil  
apparatus 100 with front face 108 (FIG. 1) removed so that  
some of the internal components are visible. It will be  
appreciated that the fan coil may be of any design known in  
the art and may use any flow path, and any heating and air  
conditioning units known in the heating and cooling arts. As  
shown, fan coil apparatus 100 includes an air blower 132  
and an air flow path 136 which extends from air blower  
outlet 140 to fan coil air outlet 116. In the illustrated  
example, the air flow path 136 includes a heating zone 148  
between an upstream first portion 144 of fan coil air flow  
path 136, and a downstream second portion 152 of fan coil  
air flow path 136. The second portion 152 of the fan coil air  
flow path 136 may include an air exit plenum 156 positioned  
upstream of fan coil air outlet 116.

Heating zone 148 can include any air heating device 160  
capable of heating the air moving downstream across the  
heating zone 148. For example, the air heating device 156  
can include a heat exchanger as shown, or resistive heating

elements, a natural gas burner or the like. In some embodiments, the air heating device **160** includes a heat recovery ventilator (HRV) or an energy recovery ventilator (ERV) that receives heat, or heat and humidity, from exhausted room air for use, e.g., in treating fresh air introduced into the unit from the outside.

Still referring to FIGS. **3** and **4**, fan coil apparatus **100** is shown including a humidification unit **164** for humidify air in the fan coil air flow path **136** so that humidified air is discharged from fan coil air outlet **116**. When air is heated in heating zone **148**, the relative humidity of the air may decrease. The humidity added by humidification unit **164** can help to maintain or increase the relative humidity of the air after heating, such as to attain or maintain a set humidity programmed into air regulating device **120**.

#### Structure of a Humidification Unit

The following is a general description of a humidification unit that may be used in any fan coil apparatus. The following description contains various features which may be used individually or in any combination or sub-combination.

As exemplified in FIG. **5**, humidification unit **164** includes a misting portion **168**, and an optional controller **172**. The misting portion **168** generates a water mist (e.g. by evaporating or atomizing water), which is exposed to the air flow path **136** in order to humidify the air. The controller **172** directs the activation of misting portion **168**. In some embodiments, controller **172** activates misting portion **168** in response to signals from air regulating device **120**. For example, controller **172** may activate misting portion **168** in response to signals from air regulating device **120** instructing that humidity is required (e.g. to attain or maintain the set air humidity programmed into air regulating device **120**). In some embodiments, controller **172** may determine not to activate misting portion **168** (e.g. determine to keep misting portion **168** deactivated) unless heating device **160** (FIG. **3**) has been activated. For example, controller **172** may determine not to activate misting portion **168** unless signals from air regulating device **120** instruct that both humidity and heat is required. An advantage of this design is that water mist is not generated unless the air flow is to be heated. Heating the air flow may reduce its relative humidity and thereby allow the air flow to better absorb the water mist. This can reduce accumulation of water (e.g., agglomerated water droplets in the water mist) inside the fan coil apparatus **100**. In alternative embodiments, controller **172** may determine to activate misting portion **168** regardless of whether heating device **160** (FIG. **3**) is to be activated as well (e.g., if the blower is operating and a sensor detects that the humidity level is below a desired set point).

Controller **172** regulates the activation of misting portion **168** by controlling the supply of water and/or power to misting portion **168**. In the illustrated embodiment, misting portion **168** receives water from a water line **176**. Misting portion water line **176** is fluidly coupled to a water supply **180**, such as a municipal water line (e.g., a water line in an apartment or condominium) or a reservoir of water (e.g. water tank) external to fan coil apparatus **100**. A shut-off valve **184** is positioned in the water flow path upstream of misting portion **168** (e.g. on water line **176**, water supply **180**, or between water supply **180** and water line **176**). The shut-off valve **184** has an open position in which water is allowed to flow past shut-off valve **184** to supply misting portion **168** with water, and a closed position in which shut-off valve **184** prevents the flow of water to misting portion **168**. Controller **172** may be communicatively coupled with shut-off valve **184** to direct the position of

shut-off valve **184**. This allows controller **172** to regulate the supply of water to misting portion **168**. Misting portion **168** may run out of water and become unable to generate water mist if the supply of water is stopped.

Shutoff valve **184** can be any valve capable of preventing the flow of water to misting portion **168** in response to electrical or mechanical direction from controller **172**. For example, shut-off valve **184** may be an electrical valve (e.g. a solenoid valve), and controller **172** may be communicatively coupled to shut-off valve **184** by electrical line **188**, whereby controller **172** can signal shut-off valve **184** to move to the open or closed position. It will be appreciated that any valve may be used.

Still referring to FIG. **5**, controller **172** may regulate the supply of power to misting portion **168** to control the activation of misting portion **168**. An advantage of this design is that controller **172** can power off misting portion **168** to immediately stop the generation of water mist, even before misting portion **168** runs out of water. Further, shutting off misting portion **168** may prevent damage that may be caused by misting portion **168** operating without any water present. In the illustrated example, misting portion **168** receives electrical power from an electrical line **192**. Misting portion electrical line **192** is electrically coupled to a power supply **196**, such as a municipal electrical grid (e.g., an electrical outlet or circuit breaker in an apartment or condominium), a power generator, or a power storage device (e.g. battery pack). Controller **172** may be positioned in a circuit between misting portion electrical line **192** and power supply **196** to regulate the supply of power from power supply **196** to misting portion **168**. Accordingly, controller **172** may prevent misting portion **168** from receiving power from power supply **196** to deactivate misting portion **168**, and allow misting portion **168** to receive power from power supply **196** to activate misting portion **168**.

Alternatively, or in addition to controlling misting portion **168** by regulating the supply of power and/or water to misting portion **168**, controller **172** may send control signals to misting portion **168** instructing misting portion **168** to activate or deactivate. For example, misting portion **168** may be continuously powered and include logic to receive and act upon control signals to start and stop water mist generation.

In some embodiments, controller **172** regulates not only the activation of misting portion **168** but also the rate of water mist generation by misting portion **168**. An advantage of this design is that it allows the rate of water mist generation to be tuned to operate more continuously (and energy efficiently) while maintaining a set air humidity. For example, controller **172** may reduce (but not halt) the flow of water or power to misting portion **168** to slow (but not necessarily stop) the rate of water mist generation. Similarly, controller **172** may send control signals to misting portion **168** instructing misting portion **168** to slow (but not necessarily halt) the rate of water mist generation. Misting portion **168** may include logic to receive and act upon such control signals to vary the rate of water mist generation.

Still referring to FIG. **5**, humidification unit **164** may optionally include a filter portion **204**. Filter portion **204** may be positioned upstream of misting portion **168** to filter water supplied to misting portion **168** for impurities such as contaminants and minerals, which can accumulate in the misting portion **168** and compromise the operation of misting unit **168** and/or the air quality discharged from fan coil apparatus **100** if dispersed into the generated water mist. In the illustrated example, filter portion **204** is positioned in the water flow path between water supply **180** and misting

portion **168**. Water delivered from water supply **180** flows through filter portion **204** before being received by misting portion **168**.

FIGS. **6-8** exemplify a misting portion **168** including an air inlet **208**, a water inlet **212**, and an air outlet **216**. Misting portion air inlet **208** receives air moving downstream in the fan coil air flow path **136**. Misting portion **168** generates water mist from water received through misting portion water inlet **212**. The generated water mist mixes with air received through misting portion air inlet **208**, and then the air and water mist mixture discharges through misting portion air outlet **216** back into the fan coil air flow path **136** to form humidified air that exits through fan coil air outlet **116** into the room.

#### Production of Air Droplets

The following is a description of an apparatus for producing droplets of air that may be used by itself or in combination with one or more other features disclosed herein including one or more of an air scoop, a misting portion water impermeable container, mist distributor, a filter portion, a leak detection control system, an air permeable water retaining member and a treatment applicator.

In accordance with this embodiment, a water mist production member **232**, may be used to produce a water mist (e.g., fine droplets of water) which may be entrained in an air flow. Any water mist production member **232** suitable for generating water mist may be used. In the illustrated embodiment, water mist production member **232** is an ultrasonic device such as a nebulizer **284**. Ultrasonic humidifier uses a ceramic diaphragm vibrating at an ultrasonic frequency to create water droplets which, when entrained in an air stream, may form a cool fog. The ultrasonic frequency produces an extremely fine mist of water droplets, e.g., about one micron in diameter, that may be quickly evaporated into an air flow. In alternative embodiments, water mist production member **232** may be an evaporator that includes a water absorptive wick exposed to air flow through the misting portion air flow path **236**, or a vaporizer that boils the water to generate steam.

It will be appreciated that, in other embodiments, any apparatus which produces water droplets may be used and, in some embodiments, it will be appreciated that any humidification unit may be used.

As exemplified in FIGS. **9-10**, misting portion **168** includes a chamber **220** containing nebulizer **284**. Chamber **220** may be of any design which houses a nebulizer **284** or other water mist production member **232** and which provides an air flow path for water droplets to be entrained in an air flow.

As exemplified, chamber **220** includes a water tank **224** positioned below an air plenum **228**. Nebulizer **284** may be positioned anywhere inside water tank **224**. Preferably, nebulizer **284** is positioned at a lower end **288** of water tank **224** so that nebulizer **284** may remain in contact with water in water tank **224**. Nebulizer **284** uses water in the water tank **224** and may cause the water mist to rise into the air plenum **228**. In other designs, the air may travel over the water mist production member **232**. The water tank **224** is in fluid communication with misting portion water inlet **212**. Water tank **224** is resupplied with water from misting portion water inlet **212** as water mist production member **232** consumes water in water tank **224** to generate water mist.

As shown, misting portion chamber **220** may include an upper wall **240** opposite a lower wall **244**, and a sidewall **248** extending between the upper wall **240** and lower wall **244**. In the illustrated example, water tank **224** is bordered by

chamber sidewall **248** and chamber lower wall **244**, and air plenum **228** is bordered by chamber sidewall **248** and chamber upper wall **240**.

Misting portion water inlet **212** may be positioned anywhere that is in fluid communication with water tank **224**. In the illustrated embodiment, misting portion water inlet **212** is positioned above and spaced apart from water tank **224** so that water from water inlet **212** falls by gravity (and water pressure) into water tank **224** below (e.g. across air plenum **228**). An advantage of this design is that the backpressure in misting portion water line **176** is constant, which makes the flow rate through misting portion water line **176** easily predictable. In contrast, submerging misting portion water inlet **212** in water tank **224** will result in a backpressure in misting portion water line **176** that varies with the water level in water tank **224**. In the illustrated embodiment, misting portion water inlet **212** is positioned in a wall of misting portion chamber **220** that borders air plenum **228**. For example, misting portion water inlet **212** may be positioned in chamber upper wall **240** as shown, or chamber sidewall **248**.

In alternative embodiments, misting portion water inlet **212** is positioned within water tank **224**. This can allow the water level in water tank **224** to be determined by measuring the backpressure in misting portion water line **176**.

Misting portion **168** includes an air flow path **236** which extends from misting portion air inlet **208** to misting portion air outlet **216**. An air plenum **228** may be positioned in the air flow path **236** between the misting portion air inlet **208** and air outlet **216**. This allows the air traveling across the air plenum **228** to entrain or absorb the generated water mist before discharging through the misting portion air outlet **216**.

Returning to FIG. **6**, misting portion **168** may be positioned anywhere in the fan coil air flow path **136**. In the illustrated example, misting portion **168** includes an air inlet **208** positioned in a first portion **144** of fan coil air flow path **136** that is upstream of heating zone **148**, and an air outlet **216** that discharges the air and water mist mixture downstream of heating zone **148**. An advantage of discharging the air and water mist mixture downstream of heating zone **148** is that the low relative humidity of the heated air allows the water mist to be more efficiently absorbed. As a result, less water mist generation may be required and less water mist may accumulate in the fan coil which may result in rusting of the apparatus or leaking of water from the fan coil apparatus. In turn, the misting portion **168** may consume less power by activating less frequently, activating at a lower power setting, or by including a less powerful water mist production member. Also, less water may be consumed by misting portion **168** because less water is lost. An advantage of positioning misting portion air inlet **208** upstream of heating zone **148** is that cooler air moves through misting portion **168**, which makes microorganisms, mold, and the like less likely to cultivate inside misting portion **168**.

#### Air Scoop

The following is a description of an air scoop that may be used by itself or in combination with one or more other features disclosed herein including one or more of a misting portion water impermeable container, mist distributor, a filter portion, a leak detection control system, an air permeable water retaining member and a treatment applicator.

Misting portion air inlet **208** may comprise, consist essentially of or consist of an air scoop **252** which diverts air from the fan coil air flow path **136** to misting portion air flow path **236**. An advantage of this design is that air flow through misting portion **168** is driven by the fan coil air blower **132**

(FIG. 3), avoiding the need for an additional air moving device to push air through misting portion 168. A further advantage is that the discharge of the air and water vapor mixture from misting portion 168 relies upon the activation of air blower 132 (FIG. 3). The air and water vapor mixture will not discharge from misting portion 168 and stagnantly collect (and accumulate such as by agglomerating into larger water droplets) in air exit plenum 156 (FIG. 3) if the air blower 132 (FIG. 3) is deactivated.

As exemplified in FIG. 10, scoop 252 may include an inlet end 256 that faces in an upstream direction 260 of the fan coil air flow path 136. Scoop 252 may have any configuration suitable for diverting air from fan coil air flow path 136 to misting portion air flow path 236. It will be appreciated that scoop 252 may face directly towards the air flow or it may be at an angle to the air flow path. In the illustrated embodiment, scoop 252 is formed as a hood that extends away from the rest of misting portion 168 in a direction 264 transverse to the downstream direction 268. This provides the scoop inlet end 256 with unobstructed exposure to the air flow moving through fan coil air flow path 136. As shown, scoop 252 may have an upper wall 272 that slopes upwardly in the downstream direction. The sloped upper wall 272 acts to redirect the diverted air into the misting portion chamber 220. Preferably, scoop 252 is configured without any 90 degree bends so as to reduce back pressure through the misting portion.

Still referring to FIG. 10, in some embodiments, scoop 252 may further include an optional air flow limiter 276 that limits the maximum air flow diverted by scoop 252 into misting portion air flow path 236. Air flow limiter 276 prevents excess air velocity through misting portion air flow path 236, which can result in unwanted air turbulence and sloshing of the water in water tank 224, which can result in larger water droplets being entrained in the air flow, which may not be absorbed by the air and may therefore fall out and produce rust or a leak. Similarly, air flow limiter 276 prevents high velocity discharge of the air and water mist mixture at misting portion air outlet 216 against the side-walls of fan coil apparatus 100 (FIG. 3), which can result in unwanted accumulation of water.

Air flow limiter 276 may have any configuration suitable for limiting the maximum air flow (e.g. maximum air velocity of air diverted) into scoop 252. Preferably, air flow limiter 276 acts passively in response to the air flow impinging on scoop 252. An advantage of this design is that it avoids the need for actuators (e.g. motors), electrical cables, and control devices that may be required by an active air flow limiter. In the illustrated example, air flow limiter 276 comprises a flap that is pivotally (e.g. hingedly) connected at one end to, e.g., the misting unit. Air flow limiter 276 may be movable (e.g. pivotally rotatable) between an open position (shown) and a closed position. In the open position (shown), air flow limiter 276 allows air to enter scoop 252. In the closed position, air flow limiter 276 may partially or completely obstruct air from entering scoop 252. As exemplified, air flow limiter 276 has an upstream face 280 oriented such that air flowing air through fan coil air flow path 136 collides with upstream face 280. The air pressure against air flow limiter upstream face 280 may move the air flow limiter 276 into the closed position when the downstream flow of air through fan coil air flow path 136 exceeds a predetermined flow rate. Accordingly, the air flow limiter may be designed such that it is fully open when air is travelling at a design velocity through air flow path 136. As

air travels at a higher rate, the air flow limiter may partially or fully close scoop 252 thereby limiting air flow into the misting unit.

It will be appreciated that, in some embodiments, air flow limiter may be actuated based on, e.g., on an air flow velocity detected by a sensor, and the sensor may send a signal to, e.g., controller 172, which actuals movement or the air flow limiter.

In other embodiments, it will be appreciated that misting portion 168 may include a separate air mover (e.g. blower, not shown). This allows the air flow through misting portion air flow path 236 and fan coil air flow path 136 to be independently controlled. In such an embodiment, a scoop 252 may not be used.

#### 15 Misting Portion Water Impermeable Container

The following is a description of misting portion water impermeable container that may be used by itself or in combination with one or more other features disclosed herein including one or more of an air scoop, mist distributor, a filter portion, a leak detection control system, an air permeable water retaining member and a treatment applica-  
tor.

In accordance with this this feature, a container is positioned to capture water which may leak from tank 224. Accordingly, as exemplified in FIG. 10, in some embodiments misting portion 220 may include an inner container 292 and an outer container 296. As shown, misting portion chamber 220 may be housed in or defined by misting portion inner container 292, and misting portion inner container 292 overlies (at least a portion of) an open interior of misting portion outer container 296. An advantage of this design is that misting portion outer container 296 may collect any water that may leak from misting portion inner container 292 (e.g. if a seal becomes broken). For example, misting portion inner container 292 may be partially and, preferably, substantially or fully nested inside misting portion outer container 296 as shown.

As exemplified, misting portion outer container 296 may include a drain 304 that provides an outlet for water collected in misting portion outer container 296. An advantage of this design is that water leaking from misting portion inner container 292 (e.g. from water tank 224) may be redirected through drain 304 to, e.g. a municipal drain, or recirculated back, e.g., into water tank 224. This prevents the leak water from spilling into the fan coil apparatus 100 and leaking into the fan coil's surroundings (e.g. inside the wall of a room). In the illustrated example, a drain conduit 308 is connected to outer container drain 304 for directing drain water downstream.

As exemplified in FIG. 5 drain conduit 308 may convey drain water toward a fan coil drain 312, which leads outside of fan coil apparatus 100, such as to a municipal drain or outdoors. Alternately, drain water may be recirculated back into misting portion 168 in any manner. As exemplified in FIG. 11 drain conduit 308 conveys drain water to recirculate back into misting portion 168. An advantage of this design is that water consumption is reduced by recycling the drain water instead of discarding the drain water (e.g. to a municipal drain).

Preferably, drain water is recirculated without any additional pumps. As exemplified in FIG. 11, drain conduit 308 directs drain water by gravity downwardly to a venturi device 316 positioned below (i.e. at a lower elevation than) outer container drain 304. Venturi device 316 includes a venturi pipe 320 having a water supply inlet 324, a drain water inlet 328, and an outlet 332. Water supply inlet 324 is fluidly connected downstream of water supply 180, drain

21

water inlet **328** is fluidly connected downstream of outer container drain conduit **308**, and venture outlet **332** is fluidly connected upstream of misting portion water inlet **212**. In use, the flow of supply water from water supply inlet **324** across venturi pipe **320** to venturi outlet **332** causes a pressure drop which draws in drain water from drain water inlet **328**. As a result, a mixture of water supply water and drain water discharges from venturi **320** through venturi outlet **332** towards misting portion water inlet **212**.

In the example of FIG. 11, venturi device **316** is positioned upstream of misting portion **168** and downstream of an optional filter portion **204**. FIG. 12 shows another example in which venturi device **316** is positioned upstream of an optional filter portion **204** (and therefore upstream of misting portion **168** as well). An advantage of this design is that the drain water may be filtered before returning to misting portion **168**.

Referring to FIGS. 13-14, in some embodiments venturi device **316** includes a filter **336** positioned upstream of venturi pipe drain water inlet **328** (as shown in FIG. 13) or positioned downstream of venturi pipe misting portion outlet **332** (as shown in FIG. 14), or both. An advantage of this design is that the drain water is filtered before return to misting portion **168**. This may be particularly advantageous where humidification unit **164** does not have a filter portion **204** to route the drain water through to filter the drain water. Mist Distributor

The following is a description of mist distributor that may be used by itself or in combination with one or more other features disclosed herein including one or more of an air scoop, a misting portion water impermeable container, a filter portion, a leak detection control system, an air permeable water retaining member and a treatment applicator.

In accordance with this feature a mist distributor **340** that distributes the generated water mist into the air moving through the fan coil air flow path **136** is provided, preferably at the air outlet of the fan coil assembly (e.g., misting portion air outlet **216**), which may extend part or all of the way across the air flow path and optionally transverse or generally transverse to the air flow direction.

Mist distributor **340** may have any configuration suitable for dispersing the generated water mist into the fan coil air flow path **136**. As exemplified in FIGS. 6 and 7, mist distributor **340** comprises a water mist distribution tube **344**. As exemplified, misting portion air outlet **216** may also include an air outlet conduit **346** upstream of mist distributor **340** to allow water mist distribution tube **344** to be remotely positioned in the air exit plenum **156** downstream of the heating zone **148**.

Water mist distribution tube **344** may be of various configurations. As exemplified in FIG. 7, water mist distribution tube **344** is a longitudinally extending tube having a length **348** extending from a first end **352** to a second end **356**. The air and water mist mixture may enter the water mist distribution tube **344** at either end, e.g., first end **352** as exemplified.

As exemplified, water mist distribution tube **344** may have a plurality of outlets **360** distributed along its length **348** and length may extend part or all the way transversely across the air flow path. It will be appreciated that, in some embodiment, two or more distribution tubes **344** may be provided, each of which may extend part or all the way across the air flow path. Further, distribution tube **344** may extend transverse or generally transverse to the direction of air flow or at an angle to the direction of air flow.

As exemplified, water mist distribution tube **344** extends transversely to the air flow direction **364** through fan coil air

22

flow path **136** across water mist distribution tube **344** and may extend part or all the way across the air flow path. For example, as exemplified in FIG. 6, water mist distribution tube **344** may have a transverse length **348** that extends at least substantially along the transverse length **368** of the air flow conduit in which it is positioned. An advantage this design is that the discharged water mist disperses more evenly across the cross-section of the fan coil air flow path **136** for better exposure to the air passing therethrough. As a result, the discharged water mist may be more efficiently absorbed into the air flow so that less water mist may accumulate in the fan coil apparatus. In turn, the misting portion **168** consumes less power by activating less frequently, by activating at a lower power setting, or by including a less powerful water mist production member. Also, less water may be consumed by misting portion **168** because less water is lost to accumulation. Depending on the depth (front to back) of the air outlet, distribution duct may be at an angle to the air flow direction, thereby permitting a longer distribution tube **344**.

Returning to FIG. 7, distribution tube **344** may include any number of outlets **360**. Preferably, distribution tube includes a plurality of outlets **360** to enhance the distribution of water mist into the fan coil air flow path **136**. In the illustrated example, distribution tube **344** includes ten outlets **360**. Distribution tube outlets **360** may have any size and shape suitable for discharging the air and water mist mixture into the fan coil air flow path **136**. For example, in other embodiments, water mist distribution tube **344** may have one or more longitudinally extending openings or slits or a plurality of slits, each of which may extend part way along length **348**. Water mist distribution tube **344** may have one or more outlets of any size which permit the air travelling through the misting unit to exit into the air flow path. In the illustrated example, each distribution tube outlet **360** is equally sized and shaped as a small circular perforation in the hollow distribution tube **344**. An advantage of this design is that the air and water mist mixture may discharge relatively equally from each distribution tube outlet **360**. In alternative embodiments, distribution tube outlet **360** may include outlets **360** of different sizes, different shapes, or both. An advantage of this design is that the size and shape of each distribution tube outlet **360** may be selected to correspond with the shape and flow characteristics of the fan coil air flow path **136**. For example, distribution tube outlets **360** nearer to the walls of the fan coil housing **104** (FIG. 6) may be sized and shaped to discharge less water mist than the more centrally located outlets **360** to reduce accumulation on the fan coil housing **104**.

Distribution tube outlets **360** may be distributed across all or any portion of the air conduit transverse length **368**. Preferably, distribution tube outlets **360** extend across at least 50%, 60%, 70%, 80%, 90% or more of air conduit transverse length **368**, as shown. An advantage of this design is that it allows the water mist discharged from the distribution tube outlets **360** to be more evenly distributed across the fan coil air flow path **136**.

Water droplets may accumulate in water mist distribution tube **344**. Therefore, distribution tube **344** may be sloped to direct the flow of accumulated water droplets inside of distribution tube **344** away from outlets **360**. An advantage of this design is that water may be inhibited from dripping out of outlets **360** of distribution tube **344**. As exemplified in FIG. 6, distribution tube second end **356** is elevated above distribution tube first end **352**. An advantage of this design is that water droplets that accumulate from the air and water mist mixture may flow by gravity towards distribution tube

first end **352**, through misting portion air outlet conduit **346**, into water tank **224**. This recycles the accumulated water to be reused for mist generation. FIG. 17 shows an example in which distribution tube first end **352** is elevated above distribution tube second end **356**. In this example, distribution tube second end **356** may be open to form a drain **392**. As shown, distribution tube drain **392** may be connected to a drain conduit **396** for directing drain water downstream to, e.g. a municipal drain or recirculation back into misting portion, as described above with respect to drain **376** and drain conduit **384** (FIG. 7). FIG. 18 shows an example in which water mist distribution tube **344** includes a central portion **402** located between and elevated above distribution tube first and second ends **352** and **356**. In this example, some water droplets that are not evaporated may flow towards distribution tube first end **352** and others towards distribution tube second end **356**. In other embodiments, it will be appreciated that distribution tube **344** may extend horizontally or in any other direction or directions.

Optionally, as exemplified in FIGS. 6-7, in some embodiments humidification unit **164** may be configured with a water impermeable container **372** positioned below (i.e. at a lower elevation than) mist distributor **340**. The water impermeable container **372** may be positioned below outlets **360** to catch dripping water droplets, accumulated from the discharging air and water mist mixture. An advantage of this design is that it prevents the water droplets from pooling inside fan coil housing **104** and potentially leaking in the apparatus surroundings (e.g. inside the wall in which apparatus **100** is recessed).

Water impermeable container **372** may have any configuration suitable for catching and optionally draining away accumulated water from mist distributor **340**. In the illustrated example, water impermeable container **372** is formed as an angled trough having a drain outlet **376** at its lower end **380**. Water collected in water impermeable container **372** will flow by gravity downwards to drain outlet **376**, which discharges the collected water (also referred to as drain water) downstream to, e.g. a municipal drain, or recirculation back into misting portion **168**. An advantage of recirculating the collected water back into misting portion **168** is that the reused water reduces water consumption by displacing water otherwise drawn from water supply **180** (FIG. 3). In the illustrated example, a drain conduit **384** is connected to drain outlet **376** for directing drain water downstream.

FIG. 7 shows an example in which drain conduit **384** directs drain water directly into the water tank of misting portion **168** to use in generating water mist. FIG. 15 shows an example in which drain conduit **384** directs drain water toward fan coil drain **312**, which leads outside of fan coil apparatus **100**, such as to a municipal drain or outdoors. FIG. 16 shows an example in which drain conduit **384** directs collected water to a venturi device **388** upstream of filter portion **204**. Venturi device **388** is substantially similar to venturi device **316** (FIG. 11), and includes a venturi pipe **320** having a water supply inlet **324**, a drain water inlet **328**, and a misting portion outlet **332**. Water supply inlet **324** is fluidly connected downstream of water supply **180**, drain water inlet **328** is fluidly connected downstream of drain outlet **376**, and misting portion outlet **332** is fluidly connected upstream of misting portion **168**, such as downstream of filter portion **204** as shown. Venturi device **388** may also include a filter **336** positioned upstream of drain water inlet **328** or downstream of misting portion outlet **332**.

#### Air Permeable Water Retaining Member

The following is a description of an air impermeable water retaining member that may be used by itself or in

combination with one or more other features disclosed herein including one or more of an air scoop, a misting portion water impermeable container, mist distributor, a filter portion, a leak detection control system, and a treatment applicator.

In accordance with this feature, humidification unit **164** may include an air permeable water retaining member **456** positioned in the fan coil air flow path **136** downstream of mist distributor **340**. The air permeable water retaining member **456** allows the humidified air flow to pass through and retain (e.g., adsorbs, adsorbs or physically retains) excess water emitted from the distributor **340** that is not entrained or evaporated into the humidified air flow. An advantage of this design is that liquid water in the air flow is removed from the air flow instead of pooling in fan coil housing **104**, a downstream air flow vent, or a room serviced by fan coil apparatus **100**.

As exemplified in FIG. 27, air permeable water retaining member **456** may be positioned anywhere in the fan coil air flow path **136** downstream of mist distributor **340**. Preferably, air permeable water retaining member **456** is spaced apart from mist distributor **340** sufficiently to allow the discharged water mist an opportunity to evaporate into the air flow. In the illustrated example, air permeable water retaining member **456** is positioned in the air exit plenum **156** immediately upstream of fan coil air outlet **116**. An advantage of this design is that water mist discharged from mist distributor **340** is given an extended opportunity to evaporate into the air flow before the remaining liquid phase water is removed from the air flow by air permeable water retaining member **456**.

Air permeable water retaining member **456** may be mounted in position in the fan coil air flow path **136** in any suitable manner. As exemplified in FIGS. 28 and 29, humidification unit **164** includes a water impermeable container **460** which holds air permeable water retaining member **456**. For example, air permeable water retaining member **456** may be seated on or located above water impermeable container **460**. An advantage of this design is that water impermeable container **460** may collect water that flows or drips from air permeable water retaining member **456**.

Water impermeable container **460** may have any configuration suitable for holding air permeable water retaining member **456** in position, and/or catching water that flows or drips from air permeable water retaining member **456**. In the illustrated example, water impermeable container **460** includes an optional drain outlet **464** that provides an outlet for water collected on water impermeable container **460**. An advantage of this design is that water that flows or drips from water impermeable container **460** may be redirected through drain outlet **464** to, e.g. a municipal drain, or recirculated back into misting portion **168**. This prevents the water collected on water impermeable container **460** from spilling into the fan coil apparatus **100** and leaking into the fan coil's surroundings (e.g. inside the wall of a room). In the illustrated example, a drain conduit **464** is connected to water impermeable container **460** for directing the drain water downstream.

Drain conduit **464** may be substantially similar to drain conduit **376**. As described previously with respect to drain conduit **376**, drain conduit **464** may direct drain water towards fan coil drain **312**, water tank **224** of misting portion **168**, or to filter portion **204** such as by way of a venturi device **388** (FIG. 16). In this regard, the description and drawings relating to drain conduit **376** apply mutatis mutandis to drain conduit **464**, and repetitive description and drawings for drain conduit **464** are not provided.

25

Air permeable water retaining member **456** may be secured or removably secured in position using any support or holding structure. Preferably, air permeable water retaining member **456** overlies (e.g. is positioned above or is seated on) water impermeable container **460** so that water may drip or flow by gravity from air permeable water retaining member **456** to water impermeable container **460**. In some embodiments, water impermeable container **460** may be integrally formed with or permanently connected to air permeable water retaining member **456**. In the illustrated example, air permeable water retaining member **456** is removably seated (e.g. removably received in) water impermeable container **460**. An advantage of this design is that it allows air permeable water retaining member **456** to be removed for cleaning, repair, or replacement should that be required.

Still referring to FIGS. **28-29**, air permeable water retaining member **456** can have any size and shape suitable for retaining excess water from the air flow in fan coil air flow path **136**. As exemplified, air permeable water retaining member **456** has a length **468** transverse to the fan coil air flow path downstream direction **268**, a height **472** transverse to the fan coil air flow path downstream direction **268**, and a thickness **476** parallel to the fan coil air flow path downstream direction **268**. The length **468** and height **472** may be sized so that air permeable water retaining member **456** spans at least a majority, and preferably substantially the entire cross-section of the fan coil air flow path **136**. An advantage of this design is that a majority or substantially all of the air flow through fan coil air flow path **136** may pass through air permeable water retaining member **456**, and therefore a majority or substantially all of the excess water can be retained by air permeable water retaining member **456**. Thickness **476** is preferably sized to optimize water retention efficiency. If thickness **476** is too great, then air permeable water retaining member **456** may obstruct the air flow through fan coil air flow path **136**. If thickness **476** is too thin, then air permeable water retaining member **456** may have too little water retention capacity.

Air permeable water retaining member **456** may be formed of any material suitable for retaining excess water from the air flow in fan coil air flow path **136** and which, preferably, will not rust. For example, air permeable water retaining member **456** may comprise an open cell material, such as an open cell foam (see e.g., FIG. **30**), an open cell plastic, an aluminum mesh, aluminum plates or the like.

For example, FIG. **31** exemplifies an air permeable water retaining member **456** includes a layered material, such as layered aluminum mesh or layered aluminum plates.

#### Filter Portion

The following is a description of an filter portion that may be used by itself or in combination with one or more other features disclosed herein including one or more of an air scoop, a misting portion water impermeable container, mist distributor, a leak detection control system, an air permeable water retaining member and a treatment applicator. Optionally, in accordance with this feature, a water filter is provided upstream of the mist production member. An advantage of this design is that, if the mist producing member is a nebulizer or the like, then scaling or fouling of the mist production member may be reduced.

FIGS. **19** and **20** exemplify a filter portion **204** which may include a water filter **404** positioned in the water flow path between water supply **180** and misting portion **168**. Water filter **404** may be any type of filter suitable for filtering water supplied to misting portion **168** (FIG. **5**) for impurities, such as contaminants and minerals. For example, water filter **404**

26

may include physical, chemical, or biological means of removing water impurities. Water filter **404** includes an inlet **408** downstream of water supply **180**, and an outlet **412** upstream of misting portion **168** (FIG. **5**). In the illustrated example, an optional shut-off valve **184** is positioned upstream of water filter inlet **408** between water filter inlet **408** and water supply **180**. In alternative embodiments, shut-off valve **184** may be positioned downstream of water filter outlet **412** or may not be provided.

Filter portion **204** may include any number of water filters **404**. FIGS. **19** and **20** show an example of filter portion **204** including one water filter **404**. An advantage of having a single water filter **404** is that only one water filter **404** needs to be periodically cleaned or replaced. FIG. **21** shows an example of filter portion **204** including a plurality of water filters **404** in series. An advantage of having a plurality of water filters in series **404** is that each water filter **404** may be specially configured to remove different impurities.

Referring again to FIGS. **19** and **20**, in some embodiments, filter portion **204** may include a leak container **416** to collect water that may leak from water filter **404** and/or shut-off valve **184**. As shown, water filter **404** and shut-off valve **184** may overlie at least a portion of an open interior of filter portion leak container **416** so that leaking water from filter portion **204** and/or shut-off valve **184** may fall by gravity into filter portion leak container **416**. An advantage of this design is that filter portion leak container **416** may collect any water that may leak from water filter **404** and/or shut-off valve **184** instead of that water pooling inside fan coil housing **104** and potentially leaking into the apparatus surroundings (e.g. inside the wall in which apparatus **100** is recessed).

As shown, filter portion leak container **416** may include a drain **420** that provides an outlet for water collected in filter portion leak container **416**. An advantage of this design is that water leaking from water filter **404** and/or shut-off valve **184** may be redirected through drain **420** to, e.g. a municipal drain, or recirculated back into the water flow path between water supply **180** and misting portion **168** (FIG. **5**). In the illustrated example, a drain conduit **424** is connected to leak container drain **420** for directing drain water downstream.

FIG. **5** shows an example in which leak container drain conduit **424** directs drain water towards fan coil drain **312**, which leads outside of fan coil apparatus **100**, such as to a municipal drain or outdoors. FIG. **22** shows an example in which leak container drain conduit **424** directs water to recirculate back into water filter inlet **408**. As shown, leak container drain conduit **424** may be fluidly connected to a venturi device **316**. The venturi device **316** combines the drain water with water from water supply **180** upstream of water filter **404**. An advantage of this design is that water consumption is reduced by recycling the drain water instead of discarding the drain water (e.g. to a municipal drain).

#### Leak Detection Control System

The following is a description of leak detection control system that may be used by itself or in combination with one or more other features disclosed herein including one or more of an air scoop, a misting portion water impermeable container, mist distributor, a filter portion, an air permeable water retaining member and a treatment applicator.

In accordance with this feature, the water supply to, e.g., tank **224**, may be shut off if a leak is detected. An advantage of this design is that water to the humidification unit may be stopped before, e.g., leak containers **296** or **416** overflow and spill water into the fan coil housing **104**.

As exemplified in FIGS. **19** and **23**, one or both of misting portion **168** and filter portion **204** may include a leak water

level detector 428. Leak water level detector 428 may be communicatively coupled (e.g. electrically connected) to a controller, which may be humidification unit controller 172. Humidification unit controller 172 may direct the shut-off valve 184 to move to the closed position in response to any one or more of the leak water level detectors 428 sensing a high water level. As exemplified, misting portion 168 may include a leak water level detector 428<sub>1</sub> to sense a water level in misting portion leak container 296, or filter portion 204 may include a leak water level detector 428<sub>2</sub> to sense a water level in filter portion leak container 416, or both.

Leak water level detectors 428 may have any configuration suitable for detecting a high water level condition in a leak container 296 or 416. For example, leak water level detectors 428 may include one or more float switches as exemplified, pressure sensors, optical sensors, capacitance sensors, ultrasonic sensors, or laser sensors. In the illustrated embodiment, water level detectors 428 are electrically connected to humidification unit controller 172 by wires 432, which may also provide water level detectors 428 with power to operate, if required. In other embodiments, other means of communication may be used including wireless (e.g., Bluetooth), optical, or the like.

In some embodiments, leak water level detectors 428 may sense the presence of a high water level and a low water level in a leak container 296 or 416. FIG. 23 shows an example of leak water level detector 428 in a first position and sensing a low water level, and FIG. 24 shows an example of the leak water level detector 428<sub>1</sub> in a second position and sensing a high water level.

Returning to FIGS. 19 and 23, preferably, humidification unit controller 172 directs shut-off valve 184 to move to its closed position in response to determining that any of the leak water level detectors 428 senses a high water level. For example, humidification unit controller 172 may intermittently poll leak water level detectors 428 for a water level status, leak water level detectors 428 may intermittently report the water level status to humidification unit controller 172, or humidification unit controller 172 may continuously monitor leak water level detectors 428 for a high or low water level status. Humidification unit controller 172 may permit shut-off valve 184 to move to its open position in response to determining that all of the leak water level detectors 428 sense a low water level. However, even if all of the leak water level detectors 428 sense a low water level, humidification unit controller 172 may yet direct shut-off valve 184 to move to or stay in the closed position until other factors are satisfied, such as receiving a signal from air regulating device 120 (FIG. 3) instructing that humidity is required.

In some embodiments, humidification unit controller 172 directs shut-off valve 184 to move to its closed position in response to determining that any one of the leak water level detectors 428 is not sensing a low water level, even if none of the leak water level detectors 428 is sensing a high water level. For example, humidification unit controller 172 may only direct or permit shut-off valve 184 to move to its open position in response to determining that each of the leak water level detectors 428 is sensing a lower water level.

Still referring to FIGS. 19 and 23, in some embodiments misting portion inner container 292 may include a water level detector 428<sub>3</sub> to sense the water level in misting portion inner container 292 and/or water tank 224. Water level detector 428<sub>3</sub> may be communicatively coupled (e.g. electrically connected) to humidification unit controller 172, such as by wire 436<sub>3</sub>. Humidification unit controller 172 may direct the shut-off valve 184 to move to the closed

position in response to water level detector 428<sub>3</sub> (or any other water level detector 428) sensing a high water level. An advantage of this design is that the water level in water tank 224 may be prevented from rising above a preset level, e.g., a the maximum water level that allows water mist production member 232 to generate water mist efficiently, and/or water tank 224 is prevented from overflowing. Once the inflow of water is shut off, the water level will lower again as the water mist production member 232 consumes water to generate water mist.

In some embodiments, water level detector 428<sub>3</sub> may also sense a low water level in water tank 224. In response, to water level detector 428<sub>3</sub> detecting a low water level, humidification unit controller 172 (FIG. 5) may deactivate water mist production member 232. For example, humidification unit controller 172 (FIG. 5) may cut power to water mist production member 232 or signal water mist production member 232 to stop generating water mist. An advantage of this design is that water mist production member 232 may be prevented from damage by operating with insufficient water present. While water mist production member 232 is deactivated, the water level in water tank 224 may rise as water flows into misting portion 168. Once the water level in water tank 224 is at a safe operating water level (e.g. once water mist production member 232 ceases to sense a low water level), the water mist production member 232 may respond by re-activate water mist production member 232.

Reference is now made to FIGS. 10 and 25-26. In some embodiments, water level detector 428<sub>3</sub> may be positioned outside of the water tank 224. For example, misting portion inner container 292 may include a water mist production member chamber 220 including water tank 224, and a water reservoir 436. As exemplified, the water tank 224 and water reservoir 436 may be separated by a separating wall 440. An advantage of this design is that the water level detector 428<sub>3</sub> is at least partially insulated from water mist production member 232. For example, separating wall 440 may at least partially insulate water level detector 428<sub>3</sub> from the high frequency ultrasonic waves emitted by nebulizer 284, which may affect, interfere with, or damage water level detector 428<sub>3</sub>.

Misting portion water reservoir 436 is fluidly coupled with water tank 224 and may be laterally spaced therefrom so that the water level in water reservoir 436 may correspond to the water level in water tank 224. This allows water level detector 428<sub>3</sub> to sense a high or low water level in water tank 224 based on the water level in misting portion water reservoir 436. In the illustrated example, misting portion water reservoir 436 is fluidly coupled to water tank 224 by a fluid flow port 444. Fluid flow port 444 may have any configuration that allows water to flow freely between water reservoir 436 and water tank 224. In the illustrated example, fluid flow port 444 is formed as an aperture, recess, or cutaway in a lower portion 448 of separating wall 440. Preferably, fluid flow port 444 is positioned at an elevation above water mist production member 232. It will be appreciated that by laterally positioning water reservoir 436 from tank 224, water level detector 428<sub>3</sub> may be set such that the high water level in water reservoir 436 corresponds to a maximum desired water level in tank 224 and, similarly, the low water level in water reservoir 436 corresponds to a minimum desired water level in tank 224.

Optionally, the air flow path through the humidification unit may pass over water reservoir 436. Accordingly, as exemplified in FIG. 10, misting portion separating wall 440 may be configured to allow (e.g. not obstruct) misting portion air flow path 236 to pass over misting portion water



reservoir **436** to the air plenum **228** above water tank **224**. For example, misting portion separating wall **440** may have an upper end **452** spaced apart from misting portion upper wall **240** as shown, or may have one or more air flow ports to allow air to flow through.

Referring to FIGS. **5** and **10**, humidification unit controller **172** may be any device suitable to execute the functionality described herein. For example, humidification unit **164** may be a computing device (e.g. including a processor and memory), or a logic circuit. In some embodiments, the relationship between the shut-off valve **184** and water level sensations by water level detectors **428** may be hardwired without use of humidification unit controller **172**. For example, FIG. **32** shows an example power circuit **490** in which power to shut-off valve **184** depends on the position (or water level sensation) of water level detectors **428**. In this example, shut-off valve **184** moves to the closed position upon losing power, and water level detectors **428** open the power circuit in response to detecting a high water level. As a result, shut-off valve **184** loses power and moves to the closed position in response to any of water level detectors **428** sensing a high water level.

As exemplified in FIG. **32**, if water level sensor **428<sub>1</sub>** detects a high water level in misting portion leak container **296**, (e.g., a float switch rises to a high water level position), then water level sensor **428<sub>1</sub>** may send a signal that opens circuit **490** as exemplified in FIG. **32**. This may occur if, e.g., the drain of misting portion leak container **296** becomes blocked and the water level in misting portion leak container **296** rises and or there is a rapid leak and the water level in misting portion leak container **296** rises. In such a case, shut off valve **184** may move to the closed position (e.g., solenoid valve may be configured to move to the closed position when the circuit is open and no power is provided to the solenoid). It will be appreciated that when the water level drops in misting portion leak container **296**, e.g., water is drained by the drain conduit, that the water level will drop and a signal may no longer be provided by the sensor (e.g., the float switch drops). Accordingly, the circuit will close, thereby providing power to shut-off valve **184** and causing the valve to open and permitting water to enter the apparatus.

Similarly, if water level sensor **428<sub>2</sub>** detects a high water level in misting portion inner container **292** and/or water tank **224** (e.g., a float switch rises to a high water level position), then water level sensor **428<sub>2</sub>** may send a signal that opens circuit **490** as exemplified in FIG. **32** and shut off valve **184** may move to the closed position. In such a case, the misting portion inner container **292** and/or water tank **224** will be at the high water level and no more water is required until the mist producing member has used sufficient water for the water level to drop and the sensor to no longer detect a high water level (e.g., a float switch drops from a high water level).

Similarly, if water level sensor **428<sub>3</sub>** detects a high water level in filter portion leak container **416** (e.g., a float switch rises to a high water level position), then water level sensor **428<sub>3</sub>** may send a signal that opens circuit **490** as exemplified in FIG. **32** and shut off valve **184** may move to the closed position. This may occur if, e.g., the drain of filter portion leak container **416** becomes blocked and the water level in filter portion leak container **416** rises and or there is a rapid leak and the water level in filter portion leak container **416** rises.

It will be appreciated that, as long as one high water level is detected, that shut off valve **184** will close the water inlet line.

In an alternate embodiment, circuit **490** may remain open until water level sensor **428<sub>1</sub>** detects a low water level in misting portion leak container **296**.

In a further alternate embodiment, shut-off valve may be configured to close if the circuit is closed. In such a case, water level sensors **428** may be configured to send a signal when not at a high water level. When they reach a high water level, they may cease sending a signal, in which case the circuit may close.

#### 10 Treatment Applicator

The following is a description of a treatment applicator that may be used by itself or in combination with one or more other features disclosed herein including one or more of an air scoop, a misting portion water impermeable container, mist distributor, a filter portion, a leak detection control system and an air permeable water retaining member.

In accordance with this feature, a treatment applicator is provided which provides a disinfecting agent to the humidification unit to inhibit and, preferably prevent the growth of microorganisms, mold, bacteria, and the like (collectively referred herein as 'organisms').

As exemplified in FIG. **27**, fan coil air flow path **136** may comprise a humidification section **480** in which water mist discharged by mist distributor **340** mixes with air flow in the fan coil air flow path **136**. In the illustrated embodiment, the humidification section **480** is shown between heating zone **148** and fan coil air outlet **116**, such as in air exit plenum **156**. However, in other embodiments, humidification section **480** may be positioned elsewhere along the fan coil air flow path **136**.

The conditions in humidification section **480** (e.g. presence of hot and humid air, and possibly accumulated water droplets) may result in the growth of organisms. Such organisms may have a negative effect of the air purity discharged from fan coil apparatus **100**. In some embodiments, fan coil apparatus **100** includes one or more treatment applicators **484** that provide one or more disinfecting agents in the humidification section **480** to reduce or eliminate organisms in the humidification section **480**. An advantage of this design is that it helps to purify the air discharged from fan coil apparatus **100** by reducing or eliminating potentially harmful organisms that may be come entrained in the air flow.

Disinfecting agents may be any element or emission that may reduce or inhibit growth of organisms in humidification section **480**, or that are harmful or lethal to organisms that may grow in humidification section **480**. Examples include ultra-violet (UV) light, ozone (O<sub>3</sub>), and hydrogen peroxide (H<sub>2</sub>O<sub>2</sub>). In the illustrated embodiment, fan coil apparatus **100** is shown including a UV light emitter **484<sub>1</sub>**, an ozone gas emitter **484<sub>2</sub>**, and a hydrogen peroxide vapor emitter **484<sub>3</sub>**, which emit UV light, ozone gas, and hydrogen peroxide vapor, respectively, into humidification section **480**.

Ozone gas may be highly effective for purifying an air flow. However, ozone gas may be also harmful to breath for humans and animals. Some embodiments which include an ozone gas emitter **484<sub>2</sub>** may also include an ozone destructor material **488** positioned in the fan coil air flow path **136** downstream of ozone gas emitter **484<sub>2</sub>**. The ozone destructor material **488** may be any material that can remove ozone gas from the air flow by adsorption or conversion to one or more other molecules. Examples include activated carbon or an ozone catalyst that converts ozone (O<sub>3</sub>) to oxygen (O<sub>2</sub>). An advantage of this design is that the ozone gas that is added to the air flow to counteract organisms in the humidification section **480** may be removed before the air flow is dis-

charged from fan coil apparatus 100. This can allow a fan coil apparatus 100 including ozone gas emitter 484<sub>2</sub> to be safely employed in, e.g. residential spaces.

Alternately or in addition, as exemplified in FIG. 23, misting portion 168 may comprise a treatment applicator 492 to counteract organisms inside misting portion 168. For example, misting portion 168 may include a treatment applicator 492 that provides a disinfecting agent in misting portion inner container 292. An advantage of this design is that it can mitigate or eliminate the growth of organisms inside misting portion inner container 292, such as organisms that may grow in water tank 224, air plenum 228, or along misting portion air flow path 236. Treatment applicator 492 may be the same as or similar to treatment applicator 484. As with treatment applicator 484, treatment applicator 492 may produce any disinfecting agent that may reduce or inhibit growth of organisms in misting portion 168, or that may be harmful or lethal to organisms that may grow in misting portion 168. Examples of disinfecting agents include ultra-violet (UV) light, ozone (O<sub>3</sub>), and hydrogen peroxide (H<sub>2</sub>O<sub>2</sub>). In the illustrated embodiment, misting portion 168 is shown including a UV light emitter 492, which emits UV light into water mist production chamber 220.

While the above description provides examples of the embodiments, it will be appreciated that some features and/or functions of the described embodiments are susceptible to modification without departing from the spirit and principles of operation of the described embodiments. Accordingly, what has been described above has been intended to be illustrative of the invention and non-limiting and it will be understood by persons skilled in the art that other variants and modifications may be made without departing from the scope of the invention as defined in the claims appended hereto. The scope of the claims should not be limited by the preferred embodiments and examples, but should be given the broadest interpretation consistent with the description as a whole.

The invention claimed is:

1. A fan coil apparatus comprising a humidification unit, the fan coil apparatus has a heating zone and an air flow path from an air inlet to an air outlet, a blower positioned in the air flow path, wherein the humidification unit is located downstream of the heating zone and downstream of the blower, the humidification unit comprising:

- (a) a water mist production member provided in an interior volume of a container wherein the interior volume is in a discrete space from the air flow path, the water mist production member is located upstream of, and in fluid communication with, a humidification unit water droplet outlet via a flow conduit extending from the container to the humidification unit water droplet outlet;
- (b) an air permeable water retaining member positioned in an air flow path downstream from a heating zone and downstream from the humidification unit water droplet outlet wherein the air permeable water retaining member is an open cell material through which air flows;
- (c) a water impermeable container positioned below the air permeable water retaining member, the water impermeable container having a drain outlet; and,

(d) a drain conduit connected in fluid flow communication with the drain outlet,

wherein the humidification unit produces a water mist wherein the water mist enters an air flow stream via the humidification unit water droplet outlet, and

wherein the air permeable water retaining member is positioned immediately upstream of the air outlet whereby the air permeable water retaining member is positioned between the air outlet and the humidification unit water droplet outlet and air travels linearly from the humidification unit water droplet outlet through the air permeable water retaining member to and through the air outlet in the absence of passing through the blower.

2. The fan coil apparatus of claim 1 wherein the humidification unit comprises an ultrasonic humidifier.

3. The fan coil apparatus of claim 1 further comprising an air outlet plenum and the humidification unit is located in the plenum.

4. The fan coil apparatus of claim 1 wherein the air permeable water retaining member has a length in a direction transverse to a direction of air flow through the air permeable water retaining member and the humidification unit comprises a mist distributor generally extending in the transverse direction.

5. The fan coil apparatus of claim 1 wherein the drain conduit is connected in fluid flow communication with a drain.

6. The fan coil apparatus of claim 1 wherein the drain conduit is connected in fluid flow communication with the humidification unit at a location upstream of the water mist production member.

7. The fan coil apparatus of claim 6 wherein the water mist production member comprises an ultrasonic humidifier and a water filter upstream of the ultrasonic humidifier and the drain conduit is connected in fluid flow communication with the humidification unit upstream of the water filter.

8. The fan coil apparatus of claim 1 wherein the drain conduit is connected in fluid flow communication with the humidification unit via a venturi.

9. The fan coil apparatus of claim 7 wherein the location upstream of the water mist production member is positioned below the water impermeable container whereby water drains from the water impermeable container through the drain conduit under the influence of gravity.

10. The fan coil apparatus of claim 1 wherein the drain conduit is connected in fluid flow communication with a water reservoir of the humidification unit.

11. The fan coil apparatus of claim 1 wherein the air permeable water retaining member is seated on the water impermeable container.

12. The fan coil apparatus of claim 1 wherein the air permeable water retaining member is removably receivable from the container.

13. The fan coil apparatus of claim 1 wherein the drain conduit is connected in fluid flow communication with the container.

\* \* \* \* \*